

Rear Freehub (for Downhill/Freeride)



User's manuals in other languages are available at :
<http://si.shimano.com>

IMPORTANT NOTICE

- Contact the place of purchase or a bicycle dealer for information on installation and adjustment of the products which are not found in the user's manual. A dealer's manual for professional and experienced bicycle mechanics is available on our website (<http://si.shimano.com>).
- Do not disassemble or alter this product.

For safety, be sure to read this user's manual thoroughly before use, and follow them for correct use.

Important Safety Information

Guidelines that require replacement, contact the place of purchase or a bicycle dealer.

WARNING

- Downhill bicycle riding and freeriding are inherently dangerous activities. There is a risk of being involved in an accident that can result in a serious injury or even death. It is strongly recommended that riders wear protective head and body gear and perform thorough safety checks of their bicycles before riding. Please remember that you are riding at your own risk and that you have to consider your experience and your skills very carefully.
- Check that the wheels are fastened securely before riding the bicycle. If the wheels are loose in any way, they may come off the bicycle and serious injury may result.
- This freehub is designed for downhill bicycle riding and freeriding. Depending on the riding conditions, the hub axle could develop cracks which may result in failure of the hub axle. This can lead to an accident that could result in serious injury or even death. Before riding, you should carefully check your hubs to make sure that there are no cracks in the axles, and if you find any sign of a crack or any other unusual condition, DO NOT use the bicycle.
- We strongly recommend that you use the hub axle that is shipped with the Shimano hub. If you use a different hub axle to secure the hub, it may not have sufficient strength to secure the freehub, or the axle may break because of insufficient strength, and this may cause the wheel to fall off, and serious injury may occur.
- After reading the user's manual carefully, keep it in a safe place for later reference.

Note

- Do not apply any lubricant to the inside of the hub, otherwise the grease will come out.
- Products are not guaranteed against natural wear and deterioration from normal use and aging.
- For maximum performance we highly recommend Shimano lubricants and maintenance products.

Regular inspections before riding the bicycle

Before riding the bicycle, check the following items. If any problems are found with the following items, contact the place of purchase or a bicycle dealer.

- Are the wheels fixed?
- Do the wheels rotate smoothly?
- Are there any abnormal noises?

Names of parts

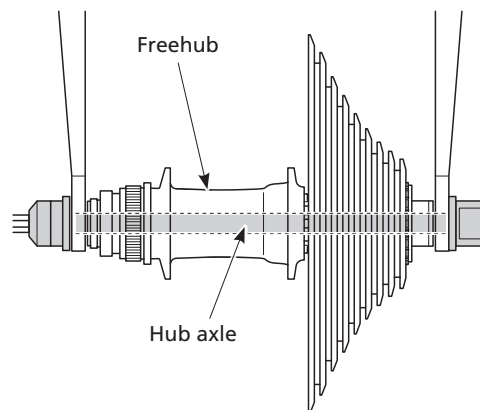

SHIMANO

SHIMANO AMERICAN CORPORATION

One Holland, Irvine, California 92618, U.S.A. Phone: +1-949-951-5003

SHIMANO EUROPE B.V.

Industrieweg 24, 8071 CT Nunspeet, The Netherlands Phone: +31-341-272222

SHIMANO INC.

3-77 Oimatsu-cho, Sakai-ku, Sakai-shi, Osaka 590-8577, Japan

Please note: specifications are subject to change for improvement without notice. (English)
©May 2012 by Shimano Inc. HTR SZK