

Internal Geared Hub 8-speed (Di2)



User's manuals in other languages are available at :
<http://si.shimano.com>

IMPORTANT NOTICE

- Contact the place of purchase or a bicycle dealer for information on installation and adjustment of the products which are not found in the user's manual. A dealer's manual for professional and experienced bicycle mechanics is available on our website (<http://si.shimano.com>).
- Do not disassemble or alter this product.

For safety, be sure to read this user's manual thoroughly before use, and follow them for correct use.

Important Safety Information

Guidelines that require replacement, contact the place of purchase or a bicycle dealer.

WARNING

- It is important to completely understand the operation of your bicycle's brake system. Improper use of your bicycle's brake system may result in a loss of control or a fall, which could lead to severe injury. Because each bicycle may handle differently, be sure to learn the proper braking technique (including brake lever pressure and bicycle control characteristics) and operation of your bicycle. This can be done by consulting your professional bicycle dealer and the bicycle's owners manual, and by practicing your riding and braking technique.
- Check that the wheels are fastened securely before riding the bicycle. If the wheels are loose in any way, they may come off the bicycle and serious injury may result.
- After reading the user's manual carefully, keep it in a safe place for later reference.

CAUTION

- Avoid continuous application of the brakes when riding down long slopes, as this will cause the internal brake parts to become very hot, and this may weaken braking performance. It may also cause a

reduction in the amount of brake grease inside the brake, and this can lead to problems such as abnormally sudden braking.

- Spin the wheel and confirm that the braking force of the brake is correct.
- If the brake is used frequently, the area around the brake may become hot. Do not touch the area around the brake for at least 30 minutes after you finish riding the bicycle.

Area around the brake

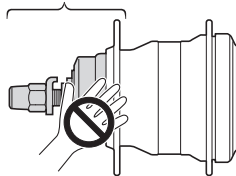

Area around the brake



Note

- You can shift gears while pedaling, but on rare occasions the pawls and ratchet inside the hub may produce some noise afterwards as part of normal gear shifting operation.
- The 8-speed hub has a built-in mechanism to support shifting. When this support mechanism operates during shifting, noise or vibration may occur. The shifting feel may also change depending on the gear position at the time of shifting. Noise may also be generated if the crank arms are turned backward or if the bicycle is pushed backward when the gear position is 5 – 8. These occurrences are a normal result of the structure of the internal gear shifting mechanism, and are not a sign of a malfunction.
- In order to maintain proper performance of the product, it is recommended that you contact the place of purchase or a bicycle dealer to carry out maintenance such as greasing the internal parts about once every two years from the first time of use (once about every 5,000 km if the bicycle is used very frequently).
- The internal hub is not completely waterproof. Avoid using the hub in places where water might get inside it and do not use high-pressure water to clean the hub, otherwise the internal mechanism may rust.
- You should periodically wash the chainrings in a neutral detergent. In addition, cleaning the chain with neutral detergent and lubricating it can be an effective way of extending the useful life of the chainrings and the chain.
- If the coaster brake wheels are not rotating smoothly, you need to replace the brake shoes. Consult the dealer where you made a purchase.
- If chain skipping has started occurring, replace the gears and the chain at a dealer or an agency.
- Products are not guaranteed against natural wear and deterioration from normal use and aging.
- For maximum performance we highly recommend Shimano lubricants and maintenance products.

Regular inspections before riding the bicycle

Before riding the bicycle, check the following items. If any problems are found with the following items, contact the place of purchase or a bicycle dealer.

- Is gear shifting carried out smoothly?
- Is there any noticeable damage to the electric wires?
- Do any abnormal noises occur during operation?

Names of parts

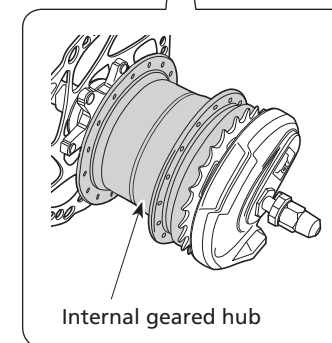

SHIMANO

SHIMANO AMERICAN CORPORATION
One Holland, Irvine, California 92618, U.S.A. Phone: +1-949-951-5003

SHIMANO EUROPE B.V.
Industrieweg 24, 8071 CT Nunspeet, The Netherlands Phone: +31-341-272222

SHIMANO INC.
3-77 Oimatsu-cho, Sakai-ku, Sakai-shi, Osaka 590-8577, Japan

Please note: specifications are subject to change for improvement without notice. (English)
© Aug. 2014 by Shimano Inc. HTR