

General Safety Information

⚠ WARNING

– To avoid serious injuries:

- It is important to completely understand the operation of your bicycle's brake system. Improper use of your bicycle's brake system may result in a loss of control or an accident, which could lead to severe injury. Because each bicycle may handle differently, be sure to learn the proper braking technique (including brake lever pressure and bicycle control characteristics) and operation of your bicycle.
- This can be done by consulting your professional bicycle dealer and the bicycle's owners manual, and by practicing your riding and braking technique.
- If the front brake is applied too strongly, the wheel may lock and the bicycle may fall forward, and serious injury may result.
- Never tighten the inner cable fixing bolt with it attached to your bicycle. Doing so may cause the inner cable fixing bolt to detach.

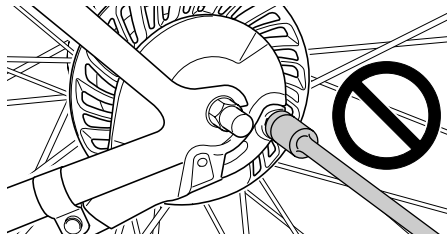

- The SB-8S20/ST-8S20/SB-7S45/BL-IM60/BL-IM65/BL-IM45 brake levers are equipped with a mode switching mechanism. Be sure to use the BR-IM81-R, BR-IM80-R, BR-IM55-R, BR-IM45-R with the mechanism in the C.R. mode position.

C.R mode position

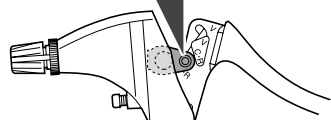

The C indicates the mode position for compatibility with cantilever brakes. The R indicates the mode position for compatibility with roller brakes.

- When securing the brake arm to the frame, be sure to use a brake arm clip that matches the size of the chainstay, and securely tighten them with the clip screw and clip nut to the specified tightening torque. Use a lock nut with a nylon insert (self-locking nut) for the clip nut. It is recommended that standard Shimano parts be used for the clip screw, clip nut and brake arm clip. In addition, use a brake arm clip that matches the size of the chainstay. If the clip nut comes off the brake arm, or if the clip screw or brake arm clip becomes damaged, the brake arm may rotate on the chainstay and cause the handlebars to jerk suddenly, or the bicycle wheel may lock and the bicycle may fall over, causing serious injury.
- Obtain and read the service instructions carefully prior to installing the parts.** Loose, worn, or damaged parts may cause serious injury to the rider. We strongly recommend only using genuine Shimano replacement parts.
- Always make sure that the front and rear brakes are working correctly before you ride the bicycle.
- If the road surface is wet, the tires will skid more easily. If the tires skid, you may fall off the bicycle. To avoid this, reduce your speed and apply the brakes early and gently.
- Read these Technical Service Instructions carefully, and keep them in a safe place for later reference.

⚠ CAUTION

– To avoid serious injuries:

- When using the Shimano Inter-M brake system, avoid continuous application of the brakes when riding down long slopes, as this will cause the internal brake parts to become very hot, and this may weaken braking performance. It may also cause a reduction in the amount of brake grease inside the brake, and this can lead to problems such as abnormally sudden braking.

The design of the Shimano Inter-M brake system has been carried out based on standards such as ISO 4210 and DIN 79100-2. These standards specify the performance for an overall weight of 100kg. However, BR-IM81-R is designed with the overall weight assumed to be 130kg. If the overall weight exceeds 100 kg (130kg for BR-IM81-R), the braking force provided by the system may be insufficient for correct braking, and durability of the system may also be reduced.

- In order to get the best performance from the Shimano Inter-M brake, be sure to use Shimano brakes cables and brake levers as a set. (The amount of movement of the inner cable must be 14.5 mm or more when the brake lever is depressed. If it is less than 14.5 mm, braking performance will suffer, and the brakes may fail to work.)

- If the hub nuts are cap nuts, use a frame with dropouts that are at least 7 mm thick.
- Check that the brake unit is firmly secured to the hub with the brake unit fixing washer.

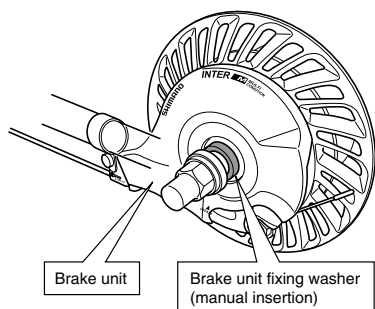

- Check that the wheel is fixed securely to the frame with the hub nuts.

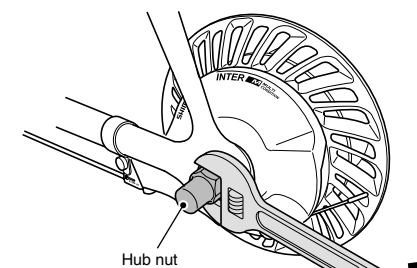

- Check that the brake arm is securely fastened to the chainstay by the brake arm clip. If it is not installed correctly, braking performance will suffer.

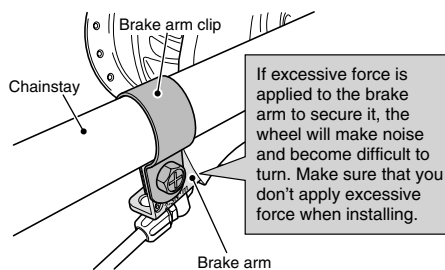

When installing the clip screw, securely hold the clip nut with a 10 mm spanner while tightening the clip screw. After tightening, check that the clip screw protrudes about 2 – 3 mm from the surface of the clip nut.

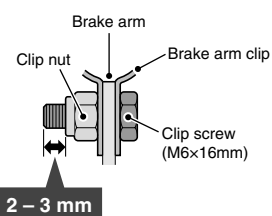

Tightening torque:
2 – 3 N·m {17 – 26 in. lbs.}

- If any of the following occur while using the brakes, stop riding immediately and ask the place of purchase to carry out inspection and repairs.
 - If abnormal noise is heard when the brakes are applied
 - If braking force is abnormally strong
 - If braking force is abnormally weak

In the case of 1) and 2), the cause might be not enough brake grease, so ask the place of purchase to grease the mechanism with special roller brake grease.

Before applying grease, be sure to remove the cable unit. Then, remove the grease hole cap and press-fit the tube into the back of the hole 12mm or more, and apply the appropriate amount of grease (approx. 5g) while turning the wheel slowly. After application, check that braking is properly applied and that no abnormal noise is heard.

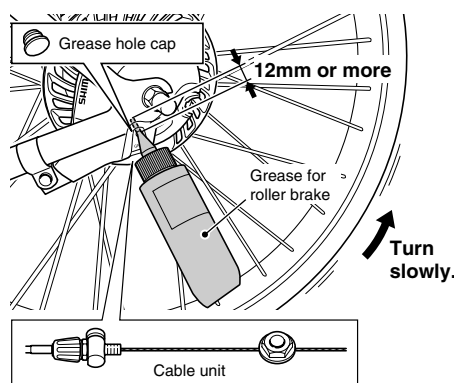

- If the brake is used frequently, the area around the brake may become hot. Do not touch the area around the brake for at least 30 minutes after you finish riding the bicycle.

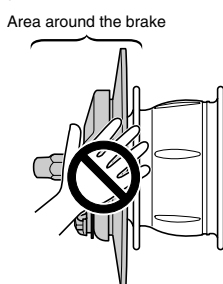

- If the brake cable becomes rusted, braking performance will suffer. If this happens, replace the brake cable with a genuine Shimano brake cable and re-check the braking performance.

- The brake unit should never be disassembled. If it is disassembled, it will no longer work properly.

Note:

- Use a wheel with 3x or 4x spoke lacing. Wheels with radial lacing cannot be used because the spokes and the wheel can be damaged when applying the brakes and brake noise can be generated.
- The Inter-M brake is different from conventional brakes in that the inside of the brake drum is filled with grease. This may cause the turning of the wheel to be slightly heavier than usual, particularly in cold weather.
- Parts are not guaranteed against natural wear or deterioration resulting from normal use.
- For maximum performance we highly recommend Shimano lubricants and maintenance products.
- For any questions regarding methods of handling or adjustment, please contact the place of purchase.

BR-IM81-R BR-IM80-R BR-IM55-R BR-IM45-R

Inter-M Brake

Technical Service Instructions



In order to realize the best performance from the Inter-M brake, we recommend that the following combinations be used.

Brake	BR-IM81-R/BR-IM80-R/BR-IM55-R/BR-IM45-R
Hub	SG-8R36/SG-8R31/SG-7R46
Lever	SB-8S20/ST-8S20/SB-7S45/BL-IM60/BL-IM65/BL-IM45
Brake cable	

Installing the brake cable

- After checking that the adjusting bolt and adjusting nut are fully tightened, insert the outer casing holder unit into the inner cable in the direction shown below.

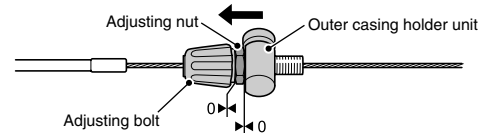

- After checking that the stamp of the back side of the inner cable fixing bolt unit is "R", pass the inner cable through the hole of the inner cable fixing bolt unit.

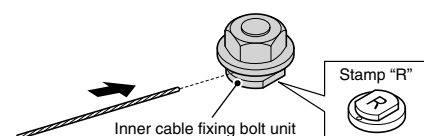

- Place the components as shown in the following figure and tighten the inner cable fixing nut. Use the TL-IM21 (inner cable fixing tool) to tighten the inner cable fixing nut as shown in Fig. 1. After tightening, check that the orientations of the inner cable fixing nut and inner cable are correct as shown in Fig. 2.

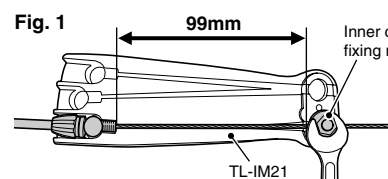

Tightening torque:
6 – 8 N·m {52 – 70 in. lbs.}

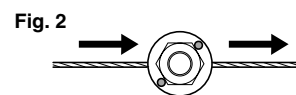

Never tighten the inner cable fixing bolt with it attached to your bicycle. The orientations of the inner cable fixing nut and inner cable will become improper as shown in Fig. 3, which may cause the inner cable fixing bolt to detach from the brake.

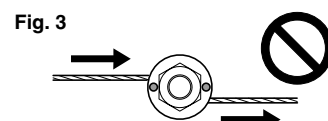

- Align the mark of the inner cable fixing washer (red) with the direction of the groove of the winder unit, and insert the inner cable fixing bolt unit and slide strongly along the groove of the winder unit as far as possible.

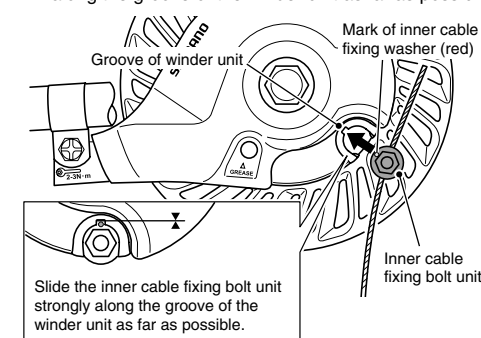

- Route the inner cable along the groove of the winder unit.

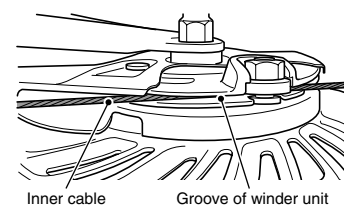

- Insert the outer casing holder unit into the hole of the brake arm from underneath and slide it to the lower section of the hole.

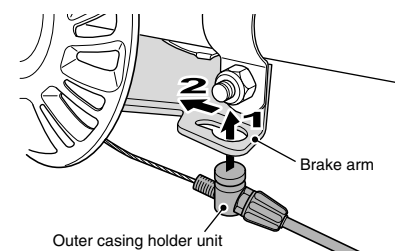

- After checking that the outer casing holder unit is inserted as far as it will go into the guide slot in the brake arm, install the inner end cap. After this, set the inner end cap so that it does not touch the fins and the spokes.

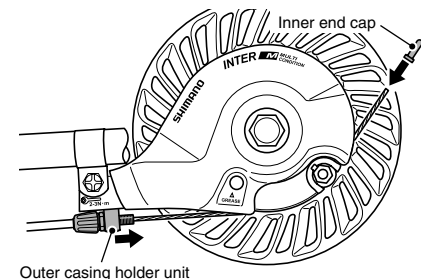

- Turn the cable adjusting bolt to tighten the inner cable.

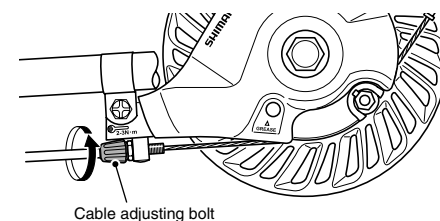

- Check that the red marks on inner cable fixing washer with the inner cable fixing bolt unit press-fit into the winder unit are in the right orientation.

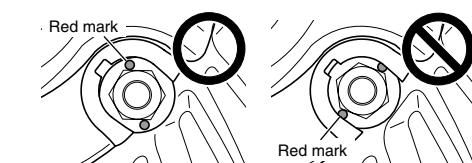

Installation of brake cable can be completed by the above procedure. When detaching the cable, perform in reverse order.

Adjusting the brake cable

- After checking that the wheel does not easily turn while the brake cable is being pulled, depress the brake lever about 10 times as far as the grip in order to run in the brake cable.

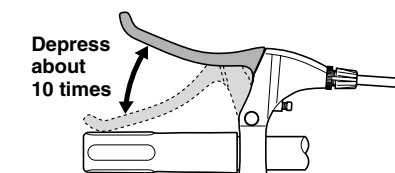

Note:
If the brake cable is not run in, it will need to be adjusted again after only a short period of use.

- Turn the cable adjusting bolt of the brake unit or brake lever so that there is about 15 mm of play in the brake lever.

(The amount of brake lever play is the distance from the position where the brake lever is not operated to the position where a force is felt suddenly when the brake lever is pulled.)

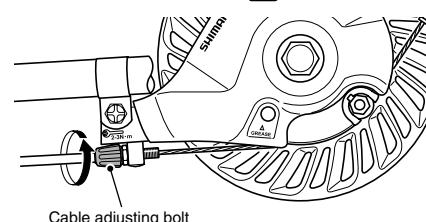
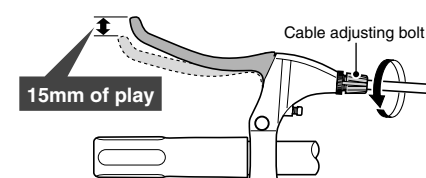

- After depressing the brake lever to check the braking performance, secure the cable adjusting bolt with the cable adjusting nut.

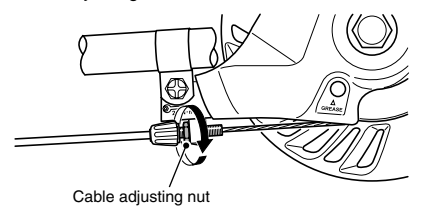

Tightening torque:
1 – 2 N·m {9 – 17 in. lbs.}

These service instructions explain how to use and maintain the Shimano bicycle parts which have been used on your new bicycle. For any questions regarding your bicycle or other matters which are not related to Shimano parts, please contact the place of purchase or the bicycle manufacturer.

* Service Instructions in further languages are available at: <http://techdocs.shimano.com>

Please note: specifications are subject to change for improvement without notice. (English)

SHIMANO

SHIMANO AMERICAN CORPORATION
One Holland, Irvine, California 92618, U.S.A. Phone: +1-949-951-5003

SHIMANO EUROPE B.V.
Industrieweg 24, 8071 CT Nunspeet, The Netherlands Phone: +31-341-272222

SHIMANO INC.
3-77 Oimatsu-cho, Sakai-ku, Sakai-shi, Osaka 590-8577, Japan