

Dealer's Manual

ROAD	MTB	Trekking
City Touring/ Comfort Bike	URBAN SPORT	E-BIKE

Front derailleur

DEORE XT

FD-T8000

DEORE

FD-T6000

CONTENTS

IMPORTANT NOTICE	3
TO ENSURE SAFETY	4
LIST OF TOOLS TO BE USED	6
INSTALLATION	8
Installation of the front derailleur.....	8
ADJUSTMENT	11
Installing the cable and adjusting shifting operation	11

IMPORTANT NOTICE

- **This dealer's manual is intended primarily for use by professional bicycle mechanics.**

Users who are not professionally trained for bicycle assembly should not attempt to install the components themselves using the dealer's manuals. If any part of the information on the manual is unclear to you, do not proceed with the installation. Instead, contact your place of purchase or a local bicycle dealer for their assistance.

- Make sure to read all instruction manuals included with the product.
- Do not disassemble or modify the product other than as stated in the information contained in this dealer's manual.
- All dealer's manuals and instruction manuals can be viewed on-line on our website (<http://si.shimano.com>).
- Please observe the appropriate rules and regulations of the country, state or region in which you conduct your business as a dealer.

For safety, be sure to read this dealer's manual thoroughly before use, and follow it for correct use.

The following instructions must be observed at all times in order to prevent personal injury and physical damage to equipment and surroundings. The instructions are classified according to the degree of danger or damage which may occur if the product is used incorrectly.



Failure to follow the instructions will result in death or serious injury.



Failure to follow the instructions could result in death or serious injury.



Failure to follow the instructions could cause personal injury or physical damage to equipment and surroundings.

TO ENSURE SAFETY

⚠ WARNING

- **Be sure to follow the instructions provided in the manuals when installing the product.**
It is recommended to use genuine Shimano parts only. If parts such as bolts and nuts become loose or damaged, the bicycle may suddenly fall over, which may cause serious injury.
In addition, if adjustments are not carried out correctly, problems may occur, and the bicycle may suddenly fall over, which may cause serious injury.
-  **Be sure to wear safety glasses or goggles to protect your eyes while performing maintenance tasks such as replacing parts.**
- After reading the dealer's manual thoroughly, keep it in a safe place for later reference.





Be sure to also inform users of the following:

- Be careful not to let the hemming of your clothes get caught in the chain while riding. Otherwise you may fall off the bicycle.

NOTE

Be sure to also inform users of the following:

- If gear shifting operations do not feel smooth, wash the derailleur and lubricate all moving parts.
- When the chain is in any of the positions shown in the illustration, the chain may come into contact with the chainring or front derailleur and generate noise. If noise is a problem, shift the chain onto the next largest sprocket or the one after if the chain is in the position shown in Figure 1. Shift the chain onto the next smallest sprocket or the one after if it is in the position shown in Figure 2.

	Figure 1	Figure 2
chainring		
sprocket		

For Installation to the Bicycle, and Maintenance:



- A triple front derailleur cannot be used with a double crankset because the shifting points do not match. Similarly, a double front derailleur cannot also be used with a triple crankset.
For detailed specifications, refer to specifications on our website for dealer's manuals.
- For frames with suspension, the chainstay angle will vary depending on whether the bicycle is being ridden or not being ridden. When the bicycle is not being ridden and the chain is positioned on the largest chainring and on the smallest sprocket, the chain guide outer plate of the front derailleur may touch the chain.
- Use an OT-SP cable and cable guide for smooth operation.
- If the amount of looseness in the links is so great that adjustment is not possible, you should replace the derailleur.
- A special grease is used for the gear shifting cable. Do not use premium grease or other types of grease, otherwise they may cause deterioration in gear shifting performance.
- Grease the inner cable and the inside of the outer casing before use to ensure that they slide properly.
- Operation of the levers related to gear shifting should be made only when the chainwheel is turning.
- Products are not guaranteed against natural wear and deterioration from normal use and aging.
- For maximum performance we highly recommend Shimano lubricants and maintenance products.

The actual product may differ from the illustration because this manual is intended mainly to explain the procedures for using the product.

LIST OF TOOLS TO BE USED

LIST OF TOOLS TO BE USED

The following tools are needed for installation, adjustment, and maintenance purposes.

Tool		Tool		Tool	
	2mm hexagon wrench		4mm hexagon wrench		8mm spanner

INSTALLATION

INSTALLATION

■ Installation of the front derailleur

NOTE

When installing components to a carbon frame/handlebar, check the tightening torque recommended by the carbon frame or component manufacturer to avoid carbon material damage due to excessive tightening or insufficient component holding force resulting from insufficient tightening torque.

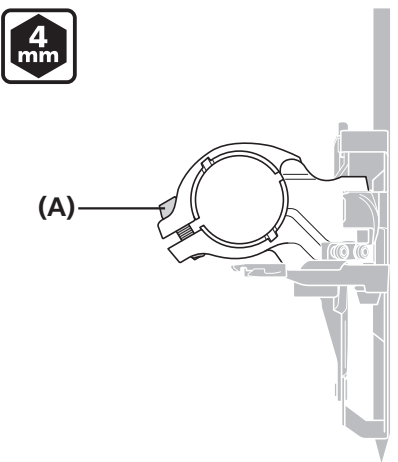
1		Temporarily attach the clamp bolt.	(A) Clamp bolt

2

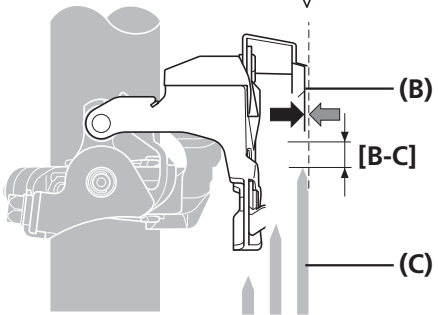
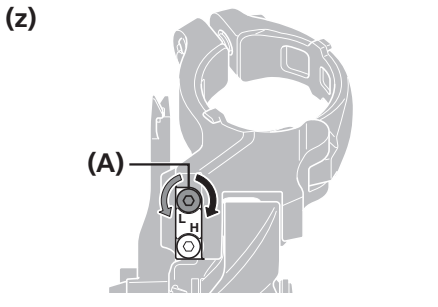
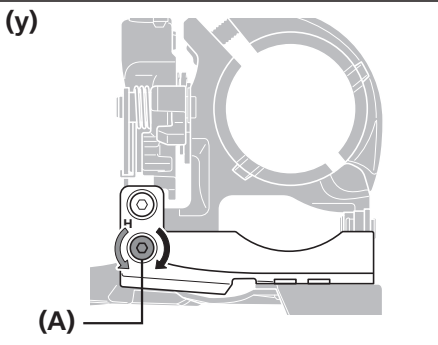

Adjust the low adjustment bolt and align the flat portion of the chain guide outer plate parallel to the flat surface of the largest chainring.

Make sure that distance [B-C] from the tip of the teeth of the largest chainring is 1 to 3mm.

[B-C] 1 - 3mm

(y) Top swing

(z) Down swing

- (A) Low adjustment bolt
- (B) Chain guide outer plate
- (C) Largest chainring

NOTE

Make sure not to position the chain guide as shown in the illustration.

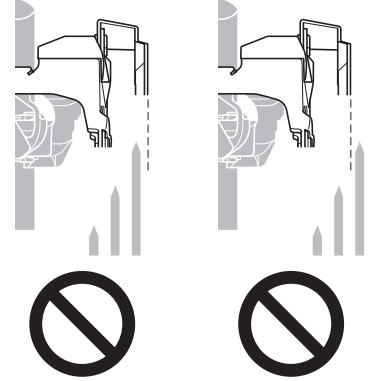

TECH TIPS

Check by holding a hexagon wrench against the flat surface of the largest chainring as shown in the illustration.

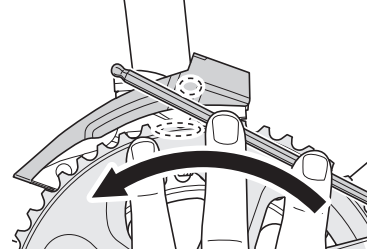

3

When adjustment is complete, tighten the clamp bolt.

Tightening torque



5 - 7 N·m

ADJUSTMENT

ADJUSTMENT

■ Installing the cable and adjusting shifting operation

Position adjustment of the low side

1

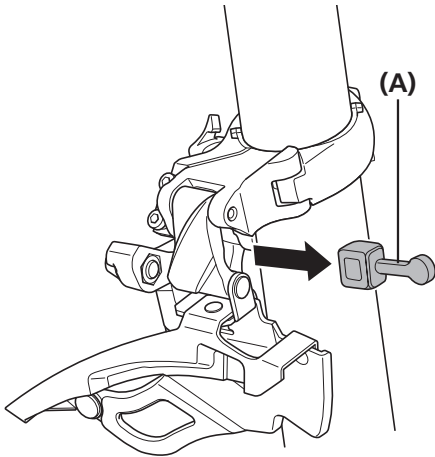

Remove the Pro-Set alignment block.

(A) Pro-Set alignment block

2

Adjust the chain position to the smallest chainring and the largest sprocket as shown in the illustration.

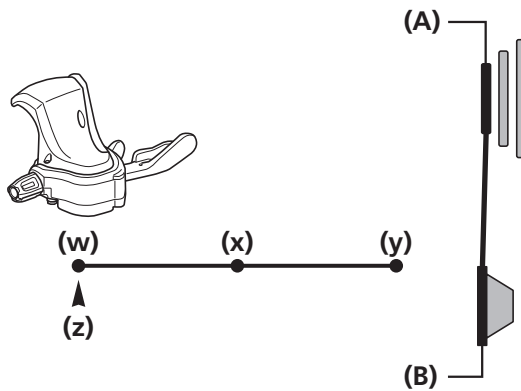

(w) Low

(x) Middle

(y) Top

(z) Cable index point

(A) Smallest chainring

(B) Largest sprocket

▶▶ Installing the cable and adjusting shifting operation

3

2 mm

(y)

(z)

(A)

(A)

(B)

(B)

(C)

[B-C]

Adjust the position of the chain guide with the low adjustment bolt.

Adjust the clearance [B-C] between the chain guide inner plate and the chain to be 0 to 0.5mm.

[B-C] 0 – 0.5mm

(y) Top swing

(z) Down swing

- (A) Low adjustment bolt
- (B) Chain guide inner plate
- (C) Chain

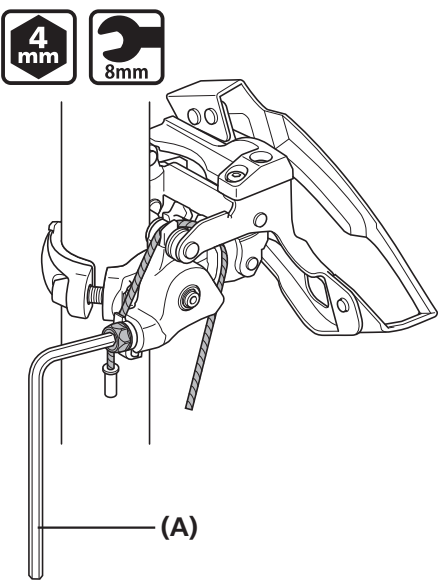

Securing the cable

Top swing



Use a spanner or a hexagon wrench to tighten the cable-fixing bolt.

(A) 4mm hexagon wrench/
8mm spanner

Tightening torque	
	<p>6 - 7 N·m</p>
	

NOTE

Run the cable through as shown in the illustration.

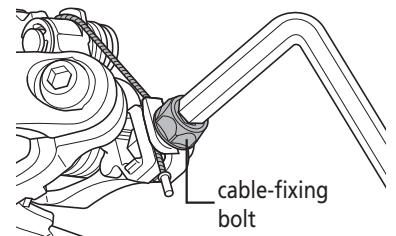

Down swing

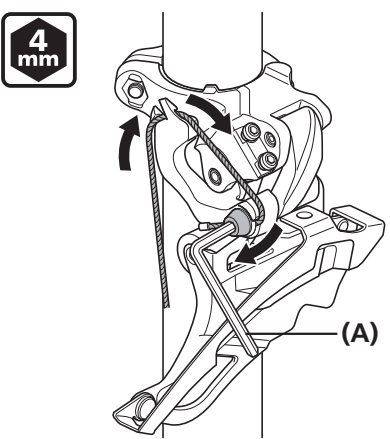

Pass the inner cable through the cable guide.

(A) 4mm hexagon wrench

Tightening torque	
	<p>6 - 7 N·m</p>

NOTE

Run the cable through as shown in the illustration.

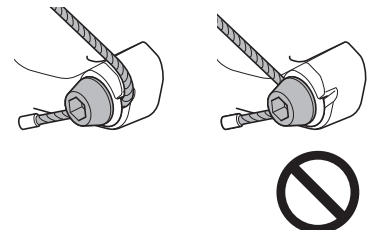

Adjustment of the cable tension

1

Adjust the chain position to the middle chainring and the largest sprocket as shown in the illustration.

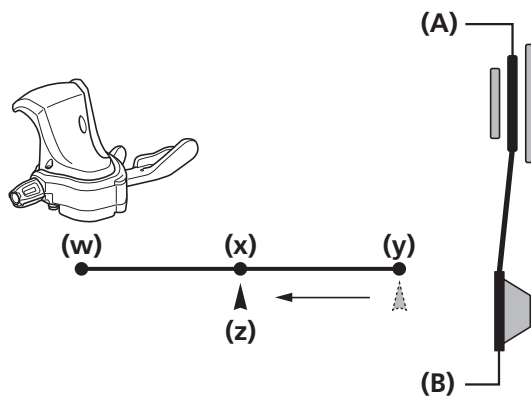

- (w) Low
- (x) Middle
- (y) Top
- (z) Cable index point

- (A) Middle chainring
- (B) Largest sprocket

NOTE

Adjust the lever after operating it from top to middle, not low to middle.

2

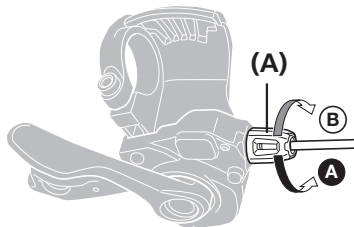

Adjust the position with the cable adjuster.

Adjust the clearance [B-C] between the chain guide inner plate and the chain to be 0 to 0.5mm.

[B-C] 0 – 0.5mm

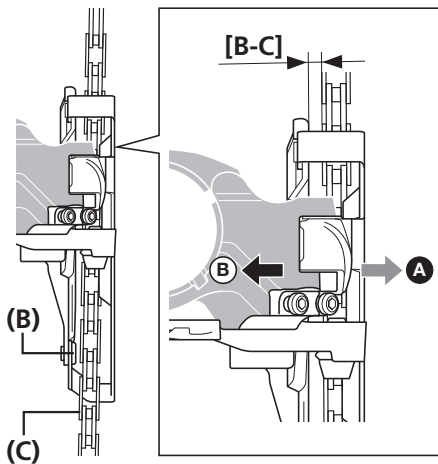

- (A) Cable adjuster
- (B) Chain guide inner plate
- (C) Chain



After adjusting the position with the cable adjuster, operate the lever once and check the clearance again.

Top adjustment

1

Adjust the chain position to the largest chainring and the smallest sprocket as shown in the illustration.

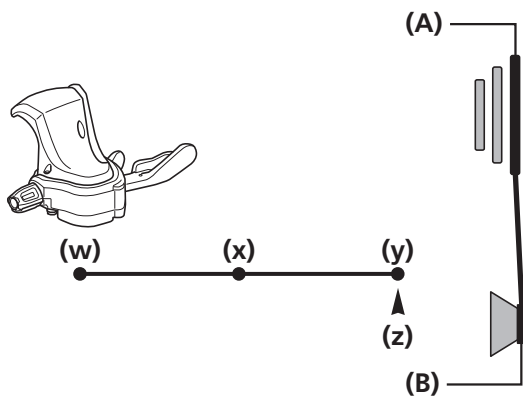

- (w)** Low
- (x)** Middle
- (y)** Top
- (z)** Cable index point

- (A)** Largest chainring
- (B)** Smallest sprocket

2

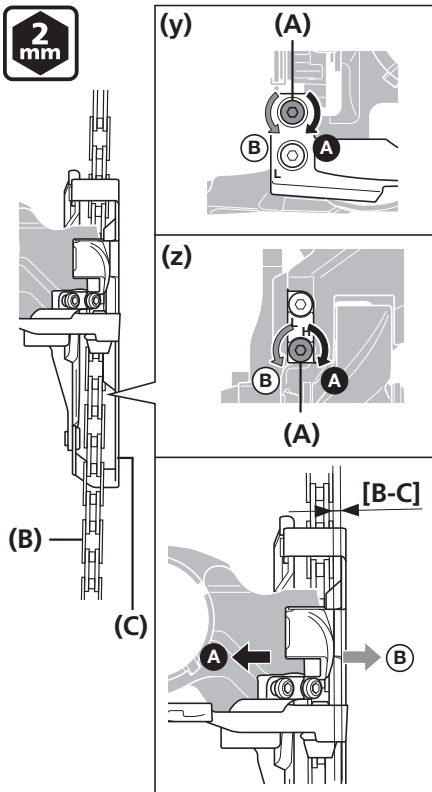

Adjust the position of the chain guide with the top adjustment bolt.

Adjust the clearance [B-C] between the chain guide outer plate and the chain to be 0 to 0.5mm.

[B-C] 0 – 0.5mm

- (y)** Top swing
- (z)** Down swing

- (A)** Top adjustment bolt
- (B)** Chain
- (C)** Chain guide outer plate

Checking gear shifting and minor adjustments

After the cable is installed and adjusted, check the gear-shift by operating the shifting lever.

(This also applies if shifting becomes difficult during use.)

Use the table as a reference when adjusting the bolts. Turn the bolt by 1/8th turn for each adjustment.

If the chain falls to the crank side.

Turn the top adjustment bolt clockwise.

If shifting is difficult from the middle chainring to the largest chainring.

Tighten the cable. If this does not improve the situation, turn the top adjustment bolt counterclockwise.

If shifting is difficult from the largest chainring to the middle chainring.

Loosen the cable.

If the chain falls to the bottom bracket side.

Turn the low adjustment bolt clockwise.

If the middle chainring is skipped when shifting from the largest chainring.

Tighten the cable.

If shifting is difficult from the middle chainring to the smallest chainring.

Turn the low adjustment bolt counterclockwise.

SHIMANO

SHIMANO AMERICAN CORPORATION

One Holland, Irvine, California 92618, U.S.A. Phone: +1-949-951-5003

SHIMANO EUROPE B.V.

High Tech Campus 92, 5656 AG Eindhoven, The Netherlands Phone: +31-402-612222

SHIMANO INC.

3-77 Oimatsu-cho, Sakai-ku, Sakai-shi, Osaka 590-8577, Japan

Please note: specifications are subject to change for improvement without notice. (English)

© Feb. 2017 by Shimano Inc. ITP