

Dealer's Manual

ROAD	MTB	Trekking
City Touring/ Comfort Bike	URBAN SPORT	E-BIKE

Front Chainwheel

Non-Series

FC-RS400
FC-RS510

Bottom bracket

BB-RS500
BB-RS500-PB

CONTENTS

IMPORTANT NOTICE.....	3
TO ENSURE SAFETY.....	4
LIST OF TOOLS TO BE USED.....	8
BB-RS500	8
BB-RS500-PB.....	8
INSTALLATION	10
Bottom bracket	10
PRESS-FIT BB	11
Installation of the crank	14
MAINTENANCE.....	17
Installation of the chainrings	17

IMPORTANT NOTICE

- **This dealer's manual is intended primarily for use by professional bicycle mechanics.**

Users who are not professionally trained for bicycle assembly should not attempt to install the components themselves using the dealer's manuals. If any part of the information on the manual is unclear to you, do not proceed with the installation. Instead, contact your place of purchase or a local bicycle dealer for their assistance.

- Make sure to read all instruction manuals included with the product.
- Do not disassemble or modify the product other than as stated in the information contained in this dealer's manual.
- All dealer's manuals and instruction manuals can be viewed on-line on our website (<http://si.shimano.com>).
- Please observe the appropriate rules and regulations of the country, state or region in which you conduct your business as a dealer.

For safety, be sure to read this dealer's manual thoroughly before use, and follow it for correct use.

The following instructions must be observed at all times in order to prevent personal injury and physical damage to equipment and surroundings. The instructions are classified according to the degree of danger or damage which may occur if the product is used incorrectly.



Failure to follow the instructions will result in death or serious injury.



Failure to follow the instructions could result in death or serious injury.



Failure to follow the instructions could cause personal injury or physical damage to equipment and surroundings.

TO ENSURE SAFETY

WARNING

- **Be sure to follow the instructions provided in the manuals when installing the product.**

It is recommended to use genuine Shimano parts only. If parts such as bolts and nuts become loose or damaged, the bicycle may suddenly fall over, which may cause serious injury.

In addition, if adjustments are not carried out correctly, problems may occur, and the bicycle may suddenly fall over, which may cause serious injury.

-  Be sure to wear safety glasses or goggles to protect your eyes while performing maintenance tasks such as replacing parts.
- After reading the dealer's manual thoroughly, keep it in a safe place for later reference.

Be sure to also inform users of the following:

- *Intervals between maintenance depend on the use and riding circumstances. Clean the chain with an appropriate chain cleaner regularly. Never use alkali based or acid based solvents, such as rust cleaners. If those solvents are used the chain might break and cause serious injury.*
- Check that there are no cracks in the crank arms before riding the bicycle. If there are any cracks, the crank arm may break and you may fall off the bicycle.
- Be careful not to let the hemming of your clothes get caught in the chain while riding. Otherwise you may fall off the bicycle.
- Check the chain for any damage (deformation or crack), skipping, or other abnormalities such as unintended gear shifting. If any problems are found, consult a dealer or an agency. The chain may break, and you may fall.

For Installation to the Bicycle, and Maintenance:

- If the inner cover is not installed correctly, the axle may rust and become damaged, and the bicycle may fall over and serious injury may occur as a result.
- The two left crank arm fixing bolts should be tightened at the same time rather than each fully tightened separately. A torque wrench should be used to check that the tightening torques are within the range of 12 - 14 N·m. Furthermore, after riding approximately 100 km (60 miles), use a torque wrench to re-check the tightening torques. It is also important to periodically check the tightening torques. If the tightening torques are too weak or if the mounting bolts are not tightened alternately in stages, the left crank arm may come off and the bicycle may fall over, and serious injury may occur as a result.

CAUTION







Be sure to also inform users of the following:

- Be careful to keep body parts away from the sharp teeth of chainrings.

NOTE

Be sure to also inform users of the following:

- Be sure to keep turning the crank during lever operation.
- When the chain is in any of the positions shown in the illustration, the chain may come into contact with the front chainring or front derailleur and generate noise. If the noise is a problem, shift the chain onto the next largest sprocket or the one after.

	Double	Triple	
Front chainring			
Rear sprocket			

- Before riding the bicycle, check that there is no play or looseness between connecting parts. Also, be sure to retighten the crank arms and pedals at periodic intervals.
- Use a neutral detergent to clean the crank arm and the bottom bracket. Using alkaline or acidic detergents may cause discoloration.
- If pedaling performance does not feel normal, check the bicycle once more.
- Do not wash the bottom bracket with high-pressure jets of water. Water may enter the bearing section and cause noise or adhesion.
- The gears should be periodically washed with a neutral detergent. In addition, cleaning the chain with neutral detergent and lubricating it can be an effective way of extending the life of the gears and the chain.
- The cuffs of your clothing may get dirty from the chain while riding.
- This product is not warranted against damage resulting from improper use, such as jumping while riding or if the bicycle falls over, except if such malfunctions are caused by manufacturing methods.
- Products are not guaranteed against natural wear and deterioration from normal use and aging.
- For maximum performance we highly recommend Shimano lubricants and maintenance products.

For Installation to the Bicycle, and Maintenance:

- When installing the pedals, apply a small amount of grease to the threads to prevent the pedals from sticking. Use a torque wrench to securely tighten the pedals. Tightening torque: 35 - 55 N·m. The right-hand crank arm has a right-hand thread, and the left-hand crank arm has a left-hand thread.
- If the bottom bracket shell is not parallel, gear shifting performance will drop.
- If the chain keeps coming off the gears during use, replace the gears and the chain.
- When installing the left and right adapters, apply grease and be sure to install the inner cover. Otherwise the waterproofing performance will worsen.
- To ensure the best performance, be sure to use only the specified type of chain.

Front chainwheel	Recommended chain
FC-RS400	CN-HG54
FC-RS510	CN-HG601

- If a squeaking noise is heard coming from the bottom bracket axle and the left crank arm connector, apply grease to the connector and then tighten it to the specified torque.
- If you feel any looseness in the bearings, the bottom bracket should be replaced.
- Be sure to use the specified gear tooth combination. If an unspecified gear is used, the chain may fall in between the gears, damaging them.

FC-RS400		Top
		50T-NA
Low	34T-NA	X







FC-RS510		Top		
		52T-MT	50T-MS	46T-MT
Low	36T-MT	X		X
	34T-MS		X	

The actual product may differ from the illustration because this manual is intended mainly to explain the procedures for using the product.



LIST OF TOOLS TO BE USED

LIST OF TOOLS TO BE USED

The following tools are needed for installation, adjustment, and maintenance purposes.

Tool		Tool	
	5 mm hexagon wrench		Plastic mallet
	8 mm hexagon wrench	 	TL-FC16/TL-FC18
	17 mm spanner		



■ BB-RS500

Tool		Tool	
	TL-FC32		TL-FC36
	TL-FC33		

NOTE

When using TL-FC32&TL-FC36, an impact wrench cannot be used.

■ BB-RS500-PB

Tool		Tool	
	TL-BB12		TL-BB13

INSTALLATION

INSTALLATION

■ Bottom bracket

Installation

1

Check that the inner cover is installed to the right adapter unit, insert the right adapter from the right side of the bottom bracket shell, and tighten 2 to 3 turns with your hand.

- (A) TL-FC32
- (B) Right hand adapter (counterclockwise thread)
- (C) Bottom bracket shell
- (D) Inner cover

Tightening torque	
 	35 - 50 N·m

2

Install the left hand adapter (clockwise thread).

- (A) TL-FC32
- (B) Left hand adapter (clockwise thread)

Tightening torque	
 	35 - 50 N·m

■ PRESS-FIT BB

Installation

Press the bottom bracket into the bottom bracket shell using TL-BB12.

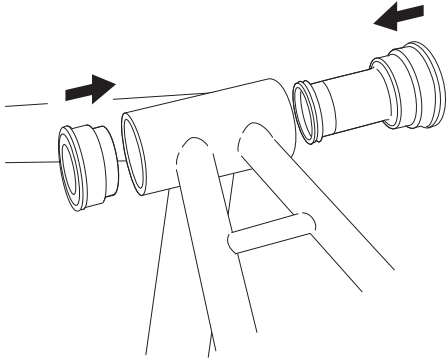
1		<p>Insert the bottom bracket into the bottom bracket shell.</p>
---	---	---

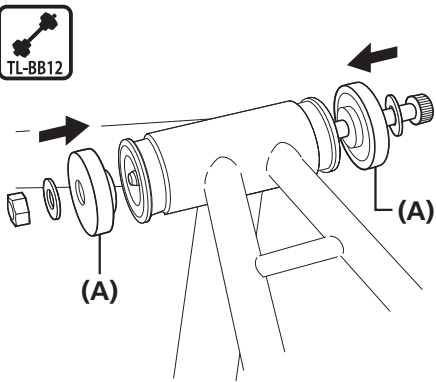
2		<p>Insert the installation tool into the bottom bracket.</p>
---	--	--

(A) TL-BB12

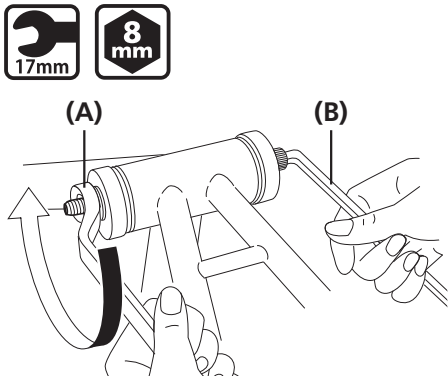
3		<p>Press-fit the bottom bracket by tightening with a spanner while making sure that the rim of the bottom bracket stays parallel to the rim of the bottom bracket shell.</p>
---	---	--

(A) 17 mm spanner

(B) 8 mm hexagon wrench

4

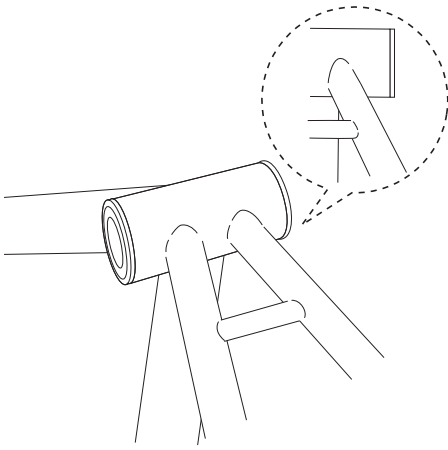

Check to confirm that there is no gap between the bottom bracket and the bottom bracket shell.

Removal

When removing the bottom bracket, use TL-BB13.

1

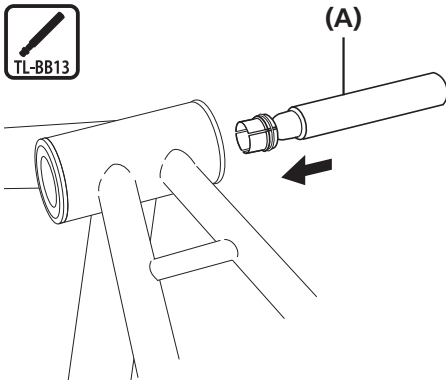

Insert the removal tool into the bottom bracket.

(A) TL-BB13

2

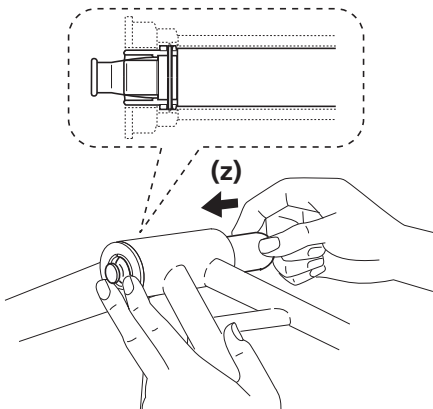

As shown in the illustration, hold down the flap with your fingers and push it in from the opposite side.

(When pushed in, the flap opens.)

(z) While holding down the flaps at the end of the removal tool, push the tool in from the other side until it locks in place.

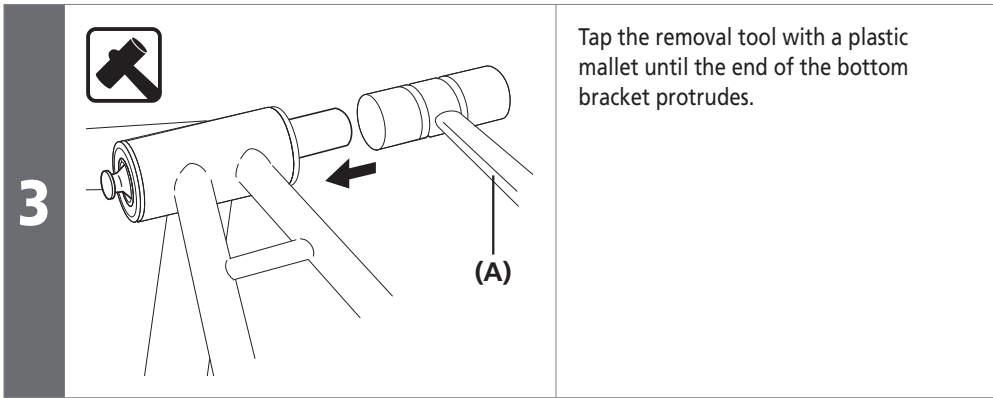

Tap the removal tool with a plastic mallet until the end of the bottom bracket protrudes.

(A) Plastic mallet

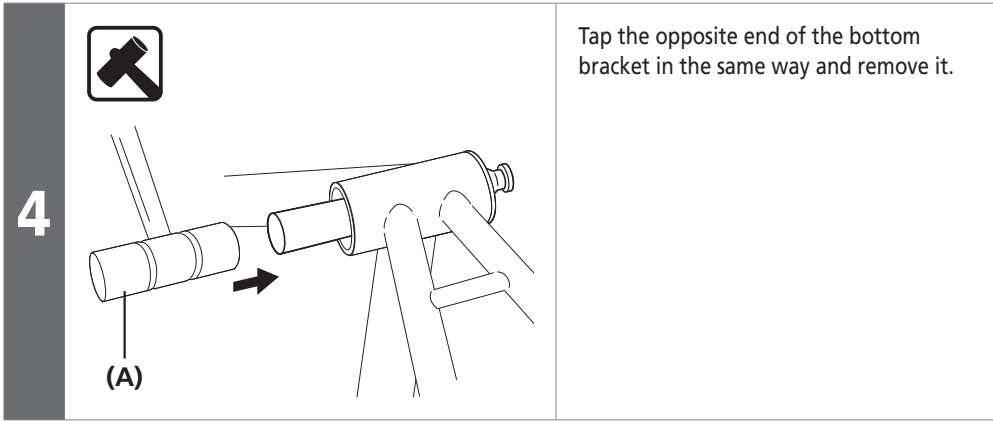

Tap the opposite end of the bottom bracket in the same way and remove it.

(A) Plastic mallet

NOTE

Do not reuse the adapters as they can be damaged during removal.

■ Installation of the crank

1

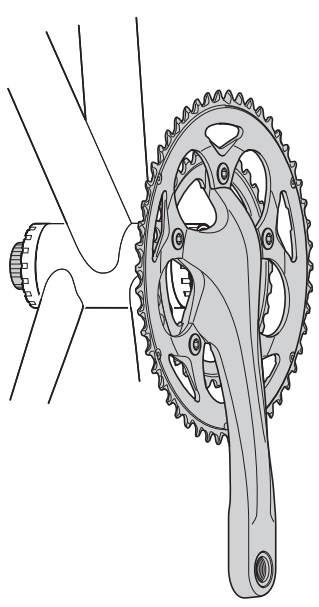

Insert the right crank unit.

The diagram shows a right crank arm with a chainring being inserted into the right side of a bottom bracket shell. The crank arm is oriented vertically, and the chainring is facing outwards. The bottom bracket shell is shown in a partial view, with the right side being the focus of the installation.

2

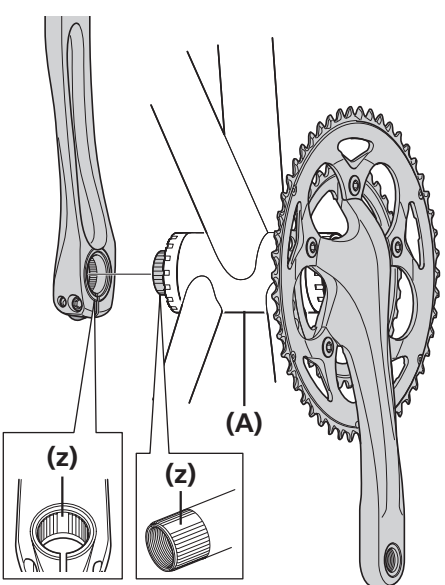

Set with the wide section of the left crank aligned with the wide section of the axle of the right crank unit.



(z) Wide part

(A) Bottom bracket shell

The diagram shows the left crank arm being inserted into the left side of the bottom bracket shell. The left crank arm is oriented vertically, and the right crank arm is already in place. The bottom bracket shell is shown in a partial view, with the left side being the focus of the installation. Two callouts labeled (z) show a close-up of the wide part of the crank arm and the wide part of the axle. A callout labeled (A) points to the bottom bracket shell.

3

Use TL-FC16/FC18 to tighten the cap.

Tightening torque	
 TL-FC16	0.7 - 1.5 N·m
 TL-FC18	

4

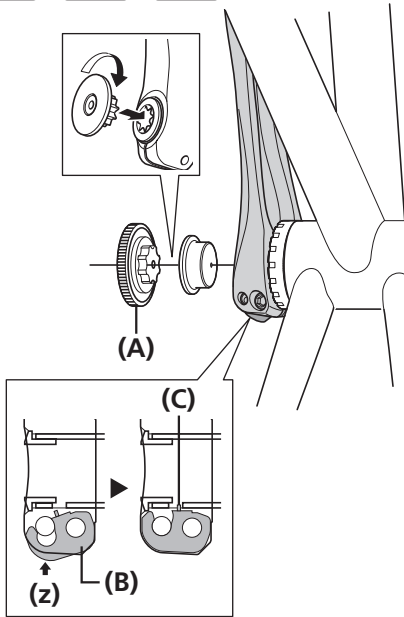

Push in the stopper plate and check that the plate pin is securely in place, and then tighten the bolt of the left crank arm.

(z) Push up

(A) TL-FC16/FC18
(B) Stopper plate
(C) Plate pin

Tightening torque	
 5 mm	12 - 14 N·m

NOTE

- The two bolts should be tightened at the same time rather than each bolt being fully tightened separately.
- Set the stopper plate in the correct direction as shown in illustration.

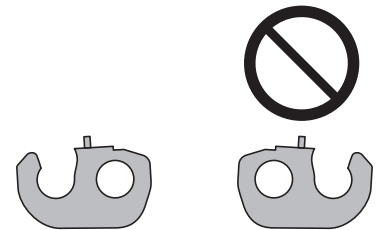

MAINTENANCE

MAINTENANCE

Installation of the chainrings

- Gear shifting performance will be reduced if the installation positions of the chainrings are incorrect. Be sure to install the chainrings in the correct positions.
- Use the correct combination of genuine Shimano bolts, chainrings and crank arm, otherwise the large chainring may become damaged by the bolts.

Outer side

With the marked surface of the largest chainring facing outward, set the chainring with the chain drop prevention pin aligned with the crank arm.



FC-RS400

FC-RS510

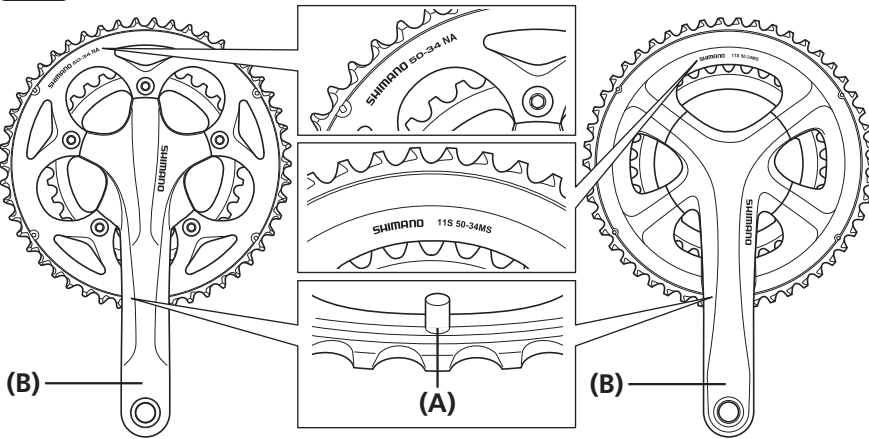

- (A) Chain drop prevention pin
- (B) Crank arm

Tightening torque



12 - 16 N·m

Inner side

With the marked side of the smallest chainring facing inward, set the smallest chainring so that the Δ mark or the convex section is positioned under the crank arm.

FC-RS400

FC-RS510

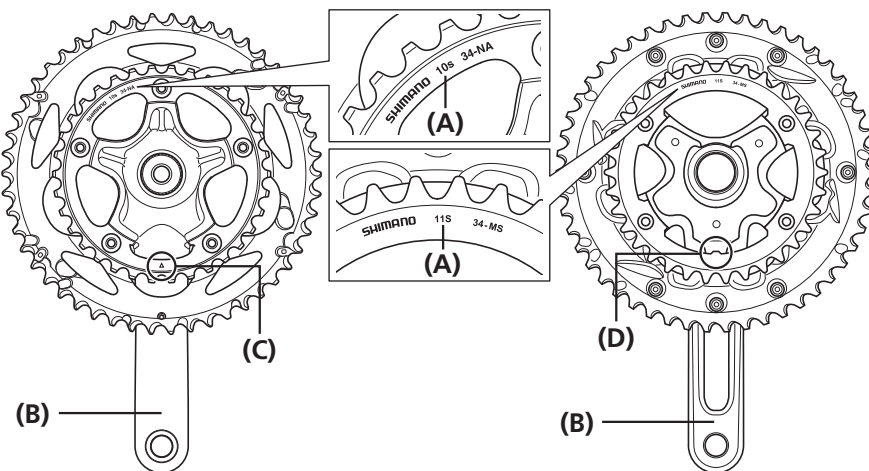

- (A) Mark
- (B) Crank arm
- (C) Δ marking
- (D) Convex section

SHIMANO

SHIMANO NORTH AMERICA BICYCLE, INC.

One Holland, Irvine, California 92618, U.S.A. Phone: +1-949-951-5003

SHIMANO EUROPE B.V.

High Tech Campus 92, 5656 AG Eindhoven, The Netherlands Phone: +31-402-612222

SHIMANO INC.

3-77 Oimatsu-cho, Sakai-ku, Sakai-shi, Osaka 590-8577, Japan

Please note: specifications are subject to change for improvement without notice. (English)

© Feb. 2018 by Shimano Inc. ITP