

Dealer's Manual

ROAD	MTB	Trekking
City Touring/ Comfort Bike	URBAN SPORT	E-BIKE

Mechanical Disc Brakes

Non-Series

BR-RS305

CONTENTS

IMPORTANT NOTICE	3
TO ENSURE SAFETY.....	4
LIST OF TOOLS TO BE USED.....	8
INSTALLATION	10
Checking the length of brake caliper mounting bolts C	10
Temporary installation to the frame.....	11
Final tightening to the frame and attaching the inner cable	17
ADJUSTMENT	22
Adjustment when the brake pads are worn	22
Checking brake pad clearance and replacement timing	23
MAINTENANCE.....	25
Replacing the brake pads	25

IMPORTANT NOTICE

- **This dealer's manual is intended primarily for use by professional bicycle mechanics.**

Users who are not professionally trained for bicycle assembly should not attempt to install the components themselves using the dealer's manuals. If any part of the information on the manual is unclear to you, do not proceed with the installation. Instead, contact your place of purchase or a local bicycle dealer for their assistance.

- Make sure to read all instruction manuals included with the product.
- Do not disassemble or modify the product other than as stated in the information contained in this dealer's manual.
- All dealer's manuals and instruction manuals can be viewed on-line on our website (<http://si.shimano.com>).
- Please observe the appropriate rules and regulations of the country, state or region in which you conduct your business as a dealer.

For safety, be sure to read this dealer's manual thoroughly before use, and follow it for correct use.

The following instructions must be observed at all times in order to prevent personal injury and physical damage to equipment and surroundings. The instructions are classified according to the degree of danger or damage which may occur if the product is used incorrectly.

 **DANGER**

Failure to follow the instructions will result in death or serious injury.

 **WARNING**

Failure to follow the instructions could result in death or serious injury.

 **CAUTION**

Failure to follow the instructions could cause personal injury or physical damage to equipment and surroundings.

TO ENSURE SAFETY

⚠ WARNING

- **Be sure to follow the instructions provided in the manuals when installing the product.**

It is recommended to use genuine Shimano parts only. If parts such as bolts and nuts become loose or damaged, the bicycle may suddenly fall over, which may cause serious injury.

In addition, if adjustments are not carried out correctly, problems may occur, and the bicycle may suddenly fall over, which may cause serious injury.

-  Be sure to wear safety glasses or goggles to protect your eyes while performing maintenance tasks such as replacing parts.
- After reading the dealer's manual thoroughly, keep it in a safe place for later reference.

Be sure to also inform users of the following:

- Please make sure to keep your fingers away from the rotating disc brake rotor. The disc brake rotor is sharp enough to inflict severe injury to your fingers if caught in the openings of the disc brake rotor while it is moving.



- The calipers and disc brake rotor will become hot when the brakes are operated; do not touch them while riding or immediately after dismounting from the bicycle. Otherwise you may get burned.
- Be careful not to allow any oil or grease to get onto the disc brake rotor and brake pads. Otherwise the brakes may not work correctly.
- If any oil or grease gets on the brake pads, consult a dealer or an agency. Otherwise the brakes may not work correctly.
- If noise occurs during brake operation, the brake pads may have been worn down to the usable limit. After checking that the temperature of the brake system has cooled down sufficiently, check that the thickness of each pad is 0.5mm or more. Or, consult a dealer or an agency.

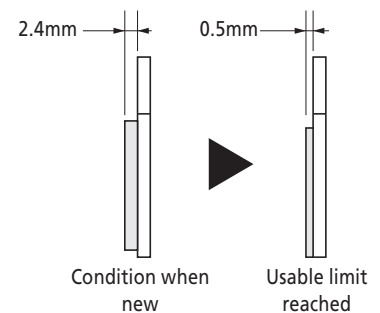

- If the brake pads are worn, read the section "Adjustment when the brake pads are worn" under "ADJUSTMENT" and adjust the brake pad clearances. Continuing to ride the bicycle without adjustment is dangerous as the brakes may stop functioning.
- If the disc brake rotor is cracked or deformed, immediately stop using the brakes and consult a dealer or an agency.
- If the disc brake rotor becomes worn down to a thickness of 1.5mm or less, or if the aluminum surface appears, immediately stop using the brakes and consult a dealer or an agency.
- Check the brake cable for rust, fraying, and cracks, and contact the place of purchase or a bicycle dealer if any such problems are found. Otherwise, the brakes may not work correctly.
- Each bicycle may handle slightly differently depending on the model. Therefore, be sure to learn the proper braking technique (including brake lever pressure and bicycle control characteristics) and operation of your bicycle.
Improper use of your bicycle's brake system may result in a loss of control or a fall, which could lead to severe injury.
For proper operation, consult a professional bicycle dealer or the bicycle's owner's manual. It is also important to practice riding and braking, etc.
- If the front brake is applied too strongly, the wheel may lock and the bicycle may fall forward, and serious injury may result.
- Always make sure that the front and rear brakes are working correctly before riding the bicycle.
- The required braking distance will be longer during wet weather. Reduce your speed and apply the brakes early and gently.
- If the road surface is wet, the tires will skid more easily. If the tires skid, you may fall off the bicycle; therefore, to avoid this, reduce your speed and apply the brakes early and gently.

For Installation to the Bicycle, and Maintenance:

- When installing the caliper to the frame, position the disc brake rotor in the center of the caliper rotor slit.
- Adjust the right and left clearances between the disc brake rotor and the brake pads so that they are equal. When the brake pads are worn down, make sure to adjust the clearances of the inboard side and outboard side evenly at the same time in order to prevent the brake pads from making contact on only one side with the rotor.
(Inboard side: pad adjustment screw; Outboard side: cable adjustment barrel/cable adjuster)
Adjusting only one of the right and left clearances may cause the clearances to become unequal and cause the brakes to fail before the brake pads are worn down to the minimum working thickness (0.5mm).

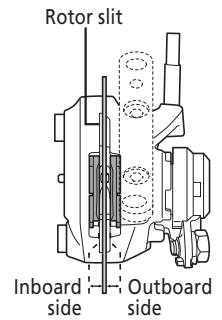

- Adjust the inner cable so that the length protruding is 20mm or less. If the protruding length is any longer, the end of the inner cable may become stuck in the disc brake rotor, which could cause the wheel to lock and the bicycle could fall forward causing serious injuries.

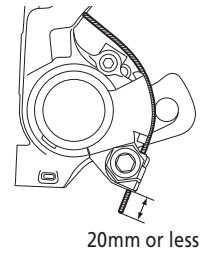

- Disc brakes are designed for optimum performance when used in the combinations shown in the recommendation tables. Be sure to refer to the recommendation tables. Combine 2-finger levers with brake calipers. If used in combination with 4-finger levers, braking force will be higher. Accordingly, certain riding positions, overall weight, and other factors may cause a fall and injury.

Lever for drop handlebars	ST-3500/ST-R3000
Lever for TT	ST-9071 BL-TT79
Lever for flat handlebars	BL-3500*/BL-R3000*

*Mode switching type brake levers. Refer to section on mode switching type brake levers.

- If the quick release lever on the hub is on the same side as the disc brake rotor, they may interfere with each other, which is dangerous, so check that they do not.

Mode switching type brake levers

- The brake levers are equipped with a mode switching mechanism which can be used to make them compatible with cantilever brakes, mechanical disc brakes for ROAD, or V-BRAKE brakes.
- For mechanical disc brakes for ROAD, use mode position C/R; for mechanical disc brakes for MTB, use mode position V.

If the incorrect mode is selected it may result in either excessive or insufficient braking force, which is highly dangerous. Select the correct mode as shown in the illustrations.

Mode position	Applicable brake
<p>C: Cantilever brake mode R: Mechanical disc brake for ROAD mode</p> <p>C/R position</p>	<p>Mechanical disc brakes for ROAD</p> <ul style="list-style-type: none"> • Use this mode for BR-RS305.
<p>V: V-BRAKE brake mode</p> <p>V position</p>	<p>Mechanical disc brake for MTB</p>

 **CAUTION**

Be sure to also inform users of the following:

■ **Burn-in period**

- Disc brakes have a burn-in period, and braking force will gradually increase as the burn-in period progresses; therefore, make sure that you are aware of any such increases in braking force when using the brakes during this period. The same thing will happen when the brake pads or disc brake rotor are replaced.

NOTE

Be sure to also inform users of the following:

- Products are not guaranteed against natural wear and deterioration from normal use and aging.
- For maximum performance we highly recommend Shimano lubricants and maintenance products.

For Installation to the Bicycle, and Maintenance:





- If the brake caliper mounting boss and the fork end are not parallel, the disc brake rotor and caliper may touch.
- Use rotors described as "RESIN PAD ONLY" only in combination with resin pads. Combining them with metal pads will cause them to wear out rapidly.

The actual product may differ from the illustration because this manual is intended mainly to explain the procedures for using the product.

LIST OF TOOLS TO BE USED

LIST OF TOOLS TO BE USED

The following tools are needed for installation, adjustment, and maintenance purposes.

Tool		Tool	
	3mm hexagon wrench		5mm hexagon wrench
	4mm hexagon wrench		10mm Spanner

INSTALLATION

INSTALLATION

■ Checking the length of brake caliper mounting bolts C

Rear (same for 140mm and 160mm)

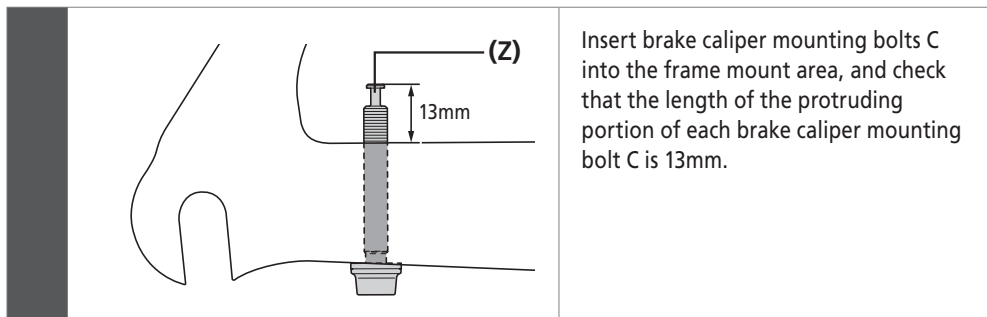

Insert brake caliper mounting bolts C into the frame mount area, and check that the length of the protruding portion of each brake caliper mounting bolt C is 13mm.

(Z) Brake caliper mounting bolt C

NOTE

- When using a bolt length selector, check whether the tip of the brake caliper mounting bolt C is within the range [X].

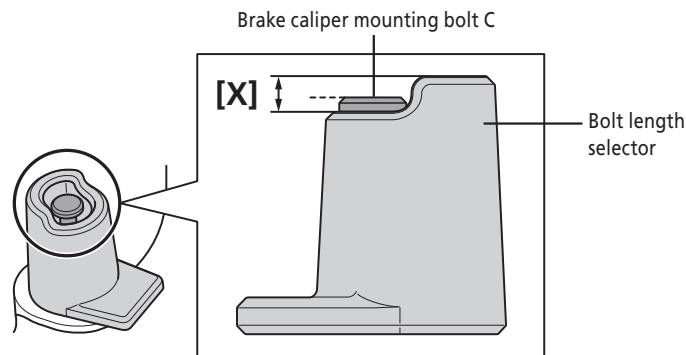

- Do not use a washer when checking the length of brake caliper mounting bolt C.
- The length of brake caliper mounting bolts C to be used vary depending on the thickness of the frame. Use brake caliper mounting bolts C that are appropriate for the thickness of the frame.

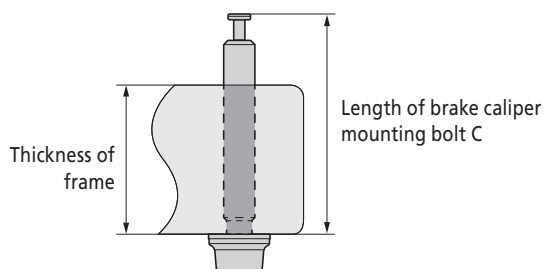

Thickness of frame	Length of brake caliper mounting bolt C	Y-part
10mm	23mm	Y8N208000
15mm	28mm	Y8N208050
20mm	33mm	Y8N208010
25mm	38mm	Y8N208020
30mm	43mm	Y8N208030
35mm	48mm	Y8N208040

INSTALLATION

►► Temporary installation to the frame

■ Temporary installation to the frame

For 140mm disc brake rotor for front wheel

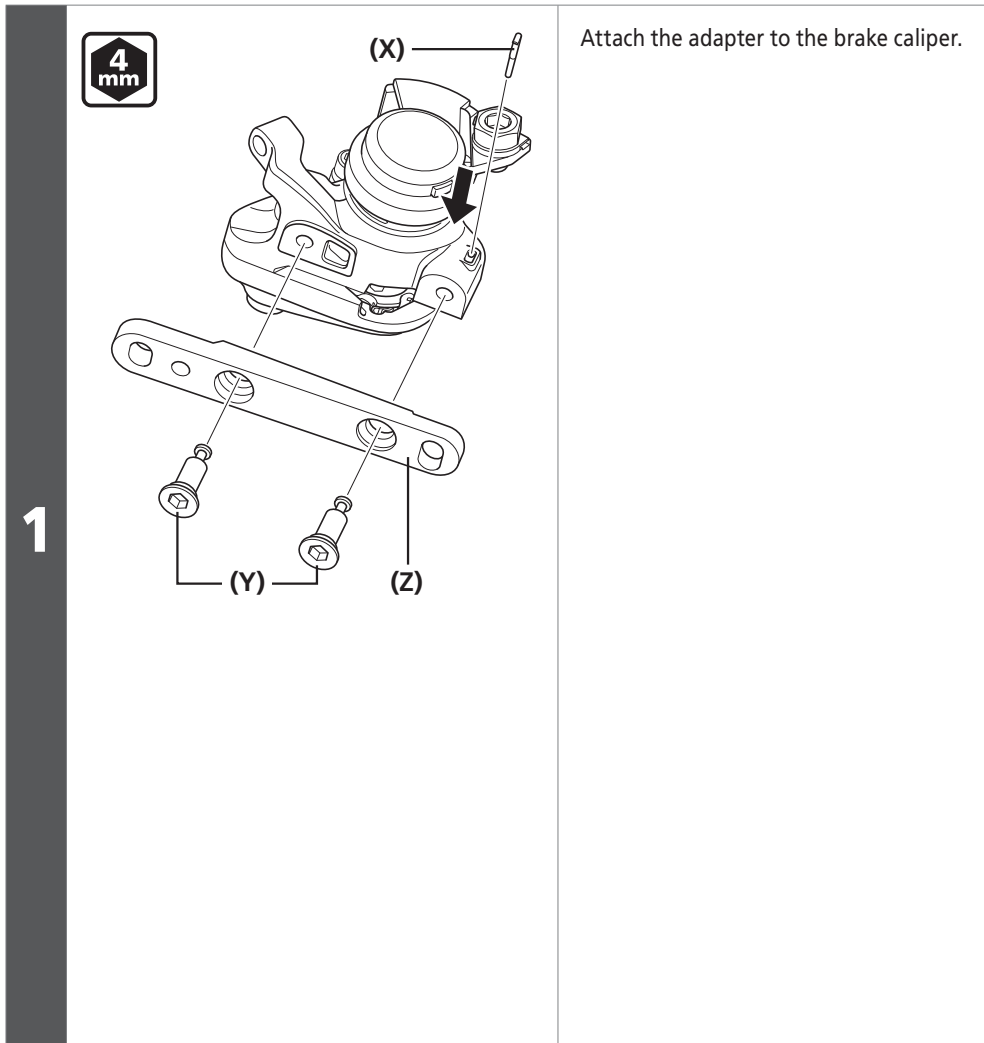

- (X) Bolt fixing pin
- (Y) Brake caliper mounting bolt B
- (Z) Adapter

Tightening torque



6 - 8 N·m

NOTE

- Be sure to attach the bolt fixing pin. Check that the bolt fixing pin is fully inserted all the way to the rear.

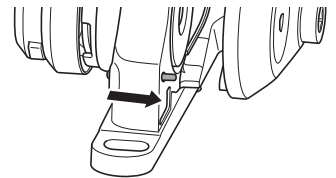

- Observe the direction indicated on the adapter when installing it.

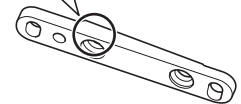
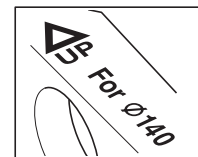

INSTALLATION

▶▶ Temporary installation to the frame

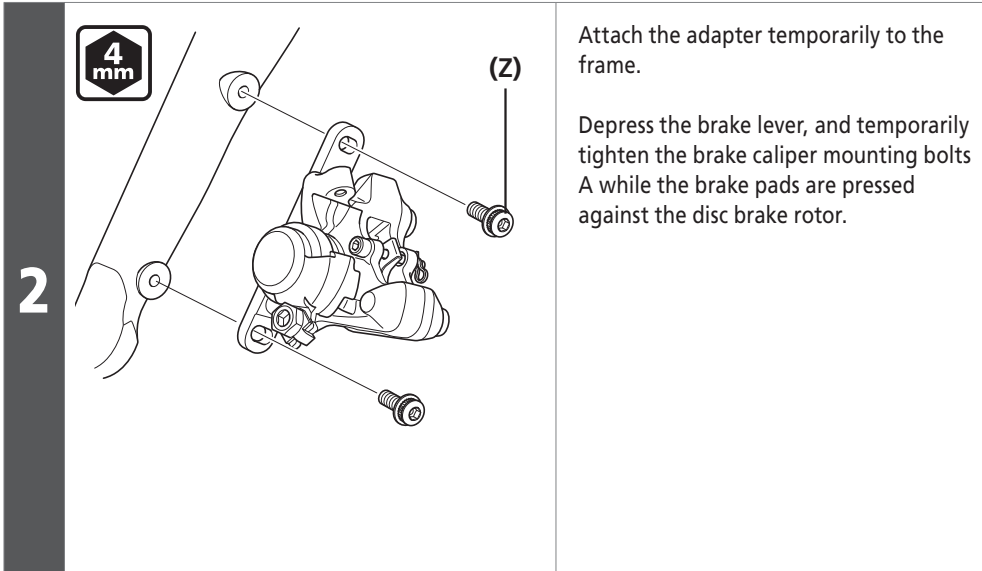

(Z) Brake caliper mounting bolt A



TECH TIPS

To aid the installation process, it is recommended to insert the inner lead (pre-threaded with the inner cable) into the caliper in advance.

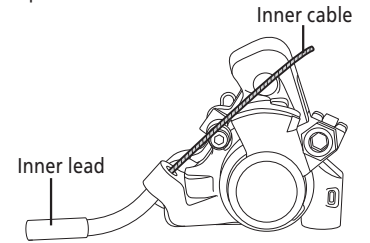

For details on completing installation to the frame and attaching the inner cable, refer to "Final tightening to the frame and attaching the inner cable".

INSTALLATION

▶▶ Temporary installation to the frame

For 160mm disc brake rotor for front wheel

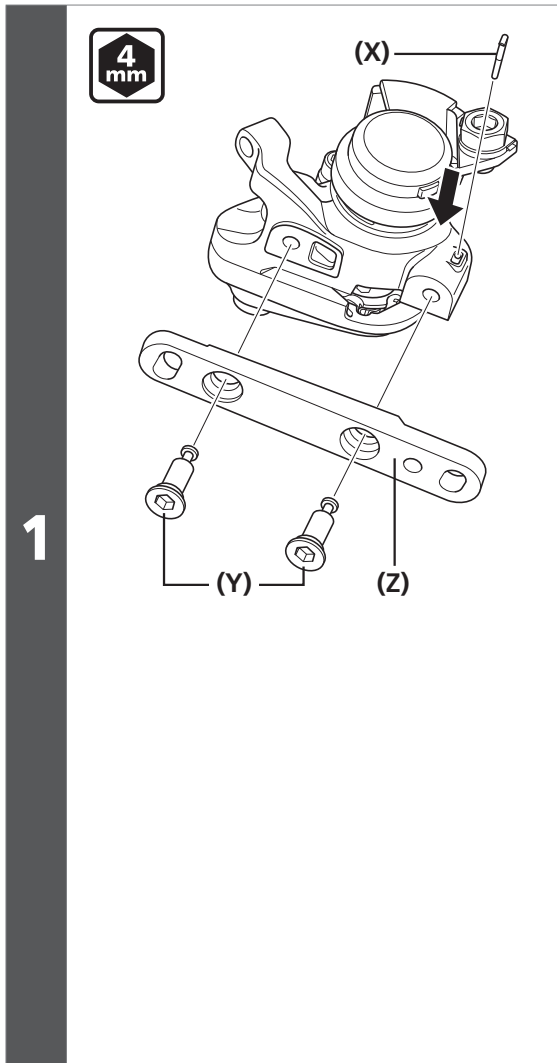

Attach the adapter to the brake caliper.

- (X) Bolt fixing pin
- (Y) Brake caliper mounting bolt B
- (Z) Adapter

Tightening torque



6 - 8 N·m

NOTE

- Be sure to attach the bolt fixing pin. Check that the bolt fixing pin is fully inserted all the way to the rear.

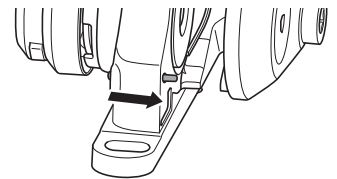

- Observe the direction indicated on the adapter when installing it.

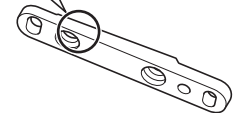
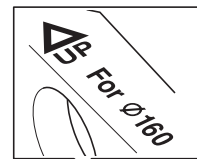

INSTALLATION

►► Temporary installation to the frame

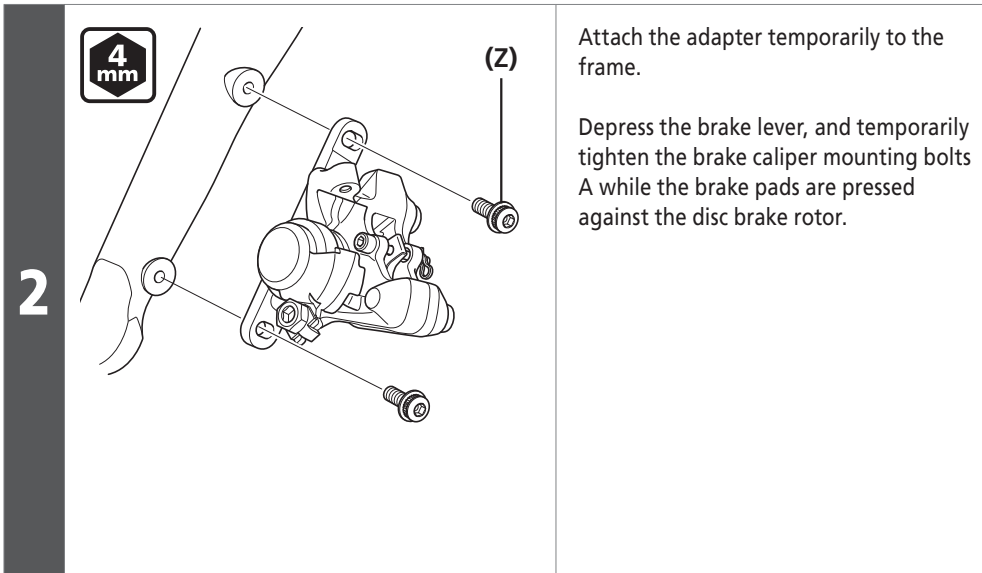

(Z) Brake caliper mounting bolt A



TECH TIPS

To aid the installation process, it is recommended to insert the inner lead (pre-threaded with the inner cable) into the caliper in advance.

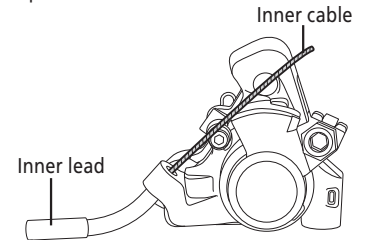

For details on completing installation to the frame and attaching the inner cable, refer to "Final tightening to the frame and attaching the inner cable".

For 140mm disc brake rotor for rear wheel

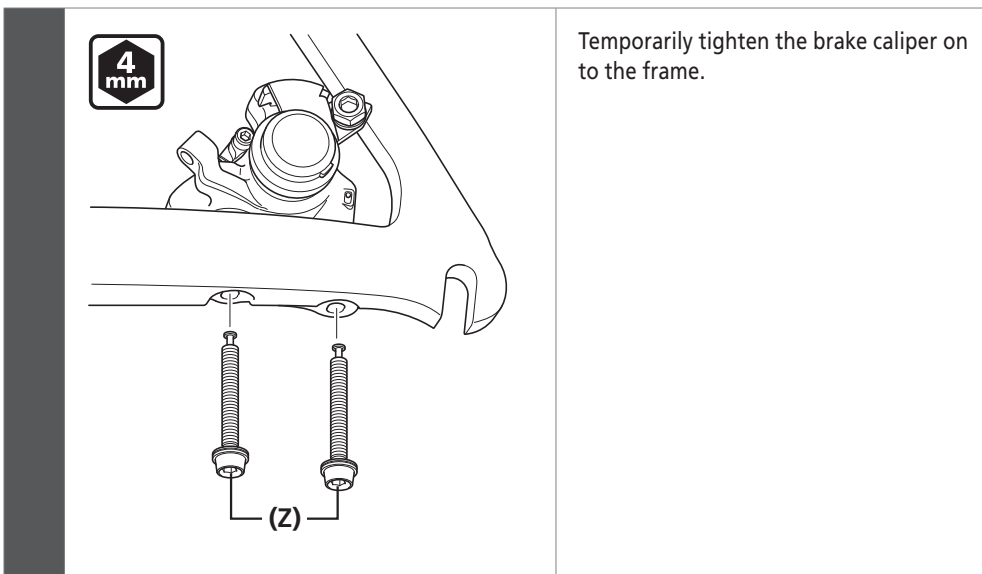

(Z) Brake caliper mounting bolt C



TECH TIPS

To aid the installation process, it is recommended to insert the inner lead (pre-threaded with the inner cable) into the caliper in advance.

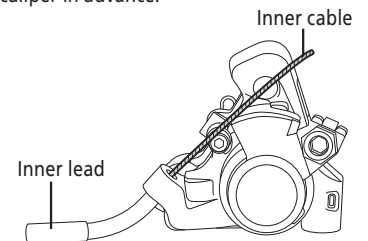

For details on completing installation to the frame and attaching the inner cable, refer to "Final tightening to the frame and attaching the inner cable".

INSTALLATION

▶▶ Temporary installation to the frame

For 160mm disc brake rotor for rear wheel

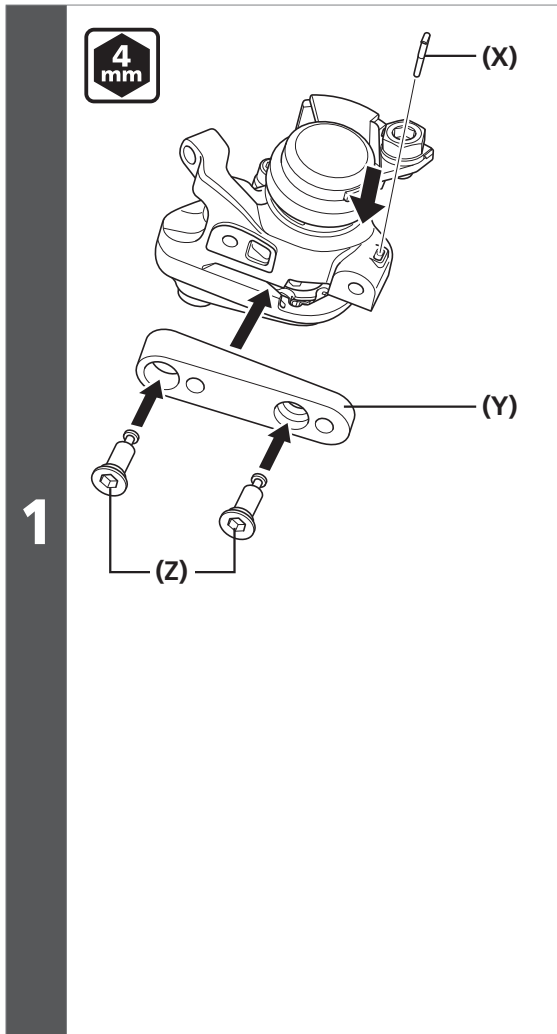

Attach the adapter to the brake caliper.

- (X) Bolt fixing pin
- (Y) Adapter
- (Z) Brake caliper mounting bolt B

Tightening torque



6 - 8 N·m

NOTE

- Be sure to attach the bolt fixing pin.

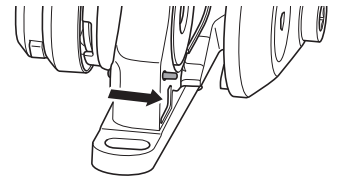

- Observe the direction indicated on the adapter when installing it.



INSTALLATION

Temporary installation to the frame

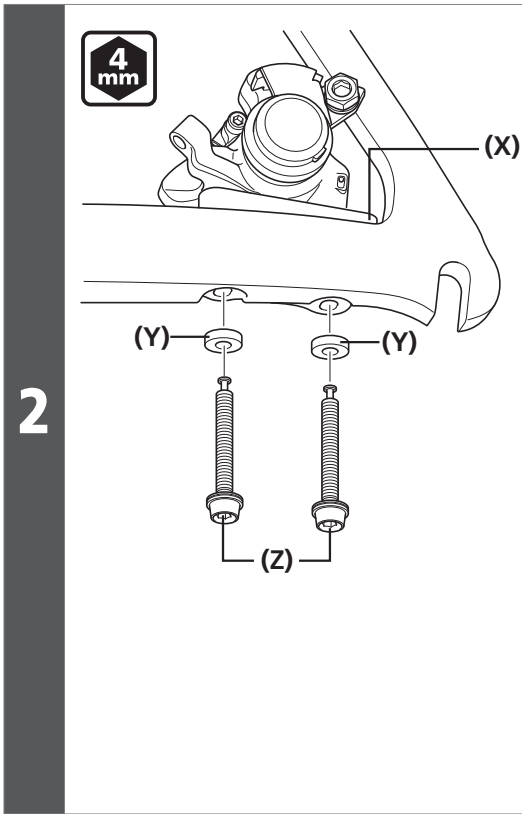

Temporarily tighten the adapter on to the frame.

- (X) Adapter
- (Y) Washer
- (Z) Brake caliper mounting bolt C



TECH TIPS

To aid the installation process, it is recommended to insert the inner lead (pre-threaded with the inner cable) into the caliper in advance.

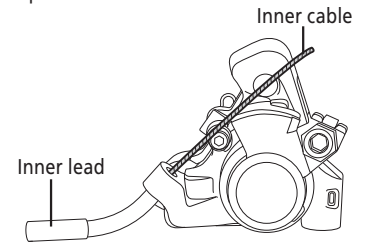

NOTE

Be sure to use the washers when installing the adapter.

For details on completing installation to the frame and attaching the inner cable, refer to "Final tightening to the frame and attaching the inner cable".

▶▶ Final tightening to the frame and attaching the inner cable

Final tightening to the frame and attaching the inner cable

1

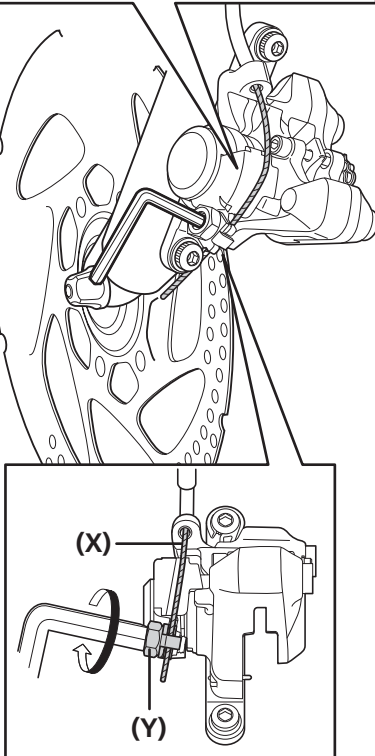
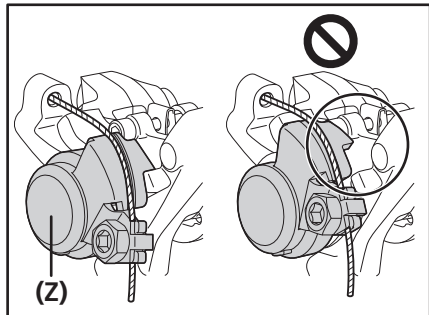

Pass the inner cable through, then with the arm in the initial position, tighten the cable fixing bolt.

- (X) Inner cable
- (Y) Cable fixing bolt
- (Z) Arm

Tightening torque	
 	6 - 8 N·m

TECH TIPS

When using a drop handlebar, you can adjust the cable with a cable adjuster (SM-CB70). Connect the cable adjuster to the outer casing then pass the inner cable through. With the caliper arm in the initial position, tighten the cable fixing bolt. For details on installation, refer to the cable adjuster manual.

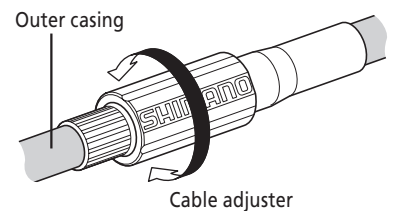

2

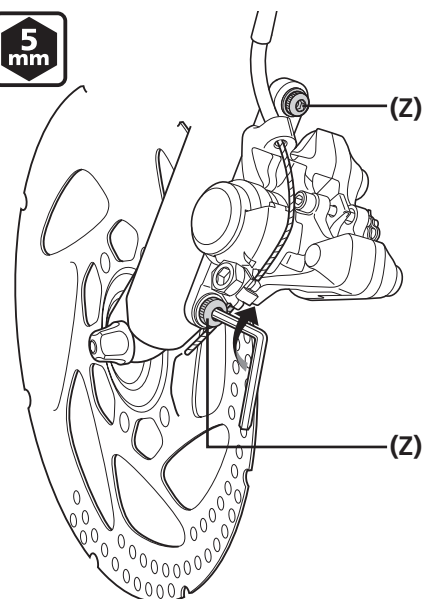

Next, secure the caliper to the frame.

Depress the brake lever until the brake pads are pressed firmly against the disc brake rotor.

While depressing the brake lever, tighten the two brake caliper mounting bolts A/C alternately in small amounts each time.

Finally, securely tighten the brake caliper fixing bolts to the specified tightening torque.

- (Z) Brake caliper mounting bolts A/C

Tightening torque	
	6 - 8 N·m

▶▶ Final tightening to the frame and attaching the inner cable

Snap rings, fixing pins, and snap retainers are used to prevent the loosening of the bolts.

Use the method suitable for the front fork and frame.

For 140mm disc brake rotor for front wheel

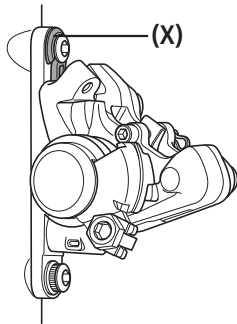

When tightening the brake caliper mounting bolts A, make sure to attach snap rings.

* Positions for attaching snap rings are different for 140mm and 160mm. (Illustration shows 140mm)

For 140mm disc brake rotor for rear wheel

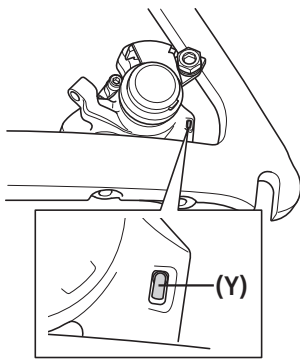

When using brake caliper mounting bolts C, make sure to attach bolt fixing pins.

Check that the fixing pins are fully inserted all the way.

For 160mm disc brake rotor for front wheel

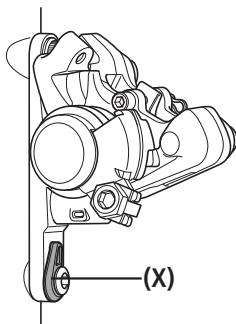

When tightening the brake caliper mounting bolts A, make sure to attach snap rings.

* Positions for attaching snap rings are different for 140mm and 160mm. (Illustration shows 160mm)

For 160mm disc brake rotor for rear wheel

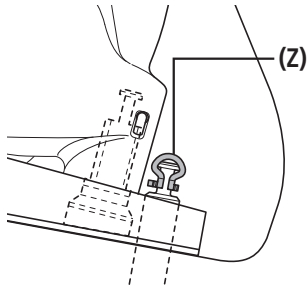

* When tightening the brake caliper mounting bolts C, make sure to attach snap retainers.

- (X) Snap ring
- (Y) Bolt fixing pin
- (Z) Snap retainer

TECH TIPS

The operations in steps 2 and 3 ensure that the caliper is installed parallel to the disc brake rotor. Check that the disc brake rotor is positioned in the center of the rotor slit of the caliper. At this point, there is some clearance between the disc brake rotor and the brake pads on the outboard side but none on the inboard side.

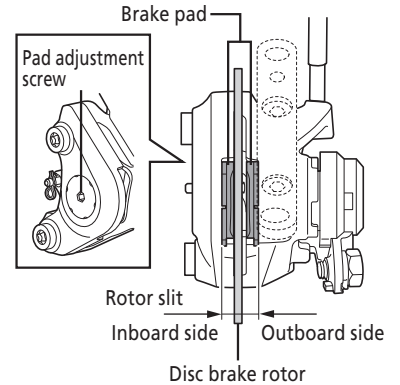

3

▶▶ Final tightening to the frame and attaching the inner cable

4

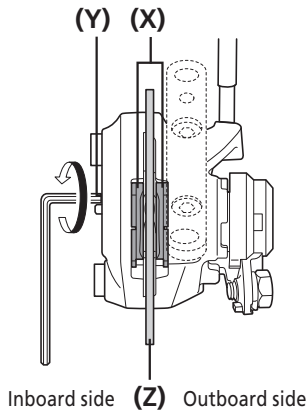

Loosen the pad adjustment screw by turning it counterclockwise one or two clicks.

This operation creates appropriate clearance between the brake pad and disc brake rotor on the inboard side.

Check that both clearances between the disc brake rotor and brake pads (on the inboard side and outboard side) are equal.

- (X)** Brake pad
- (Y)** Pad adjustment screw
- (Z)** Disc brake rotor

5

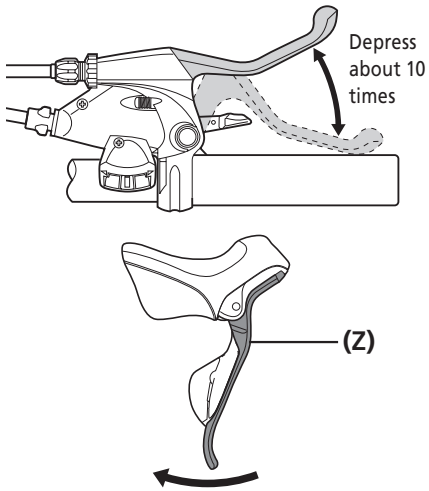

Depress the brake lever about 10 times until it touches the grip; check that there are no problems with any components, and that the disc brake rotors and the brake pads do not interfere with each other when the wheel is rotated.

- (Z)** Brake lever

►► Final tightening to the frame and attaching the inner cable

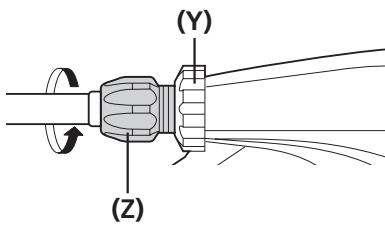
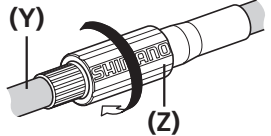
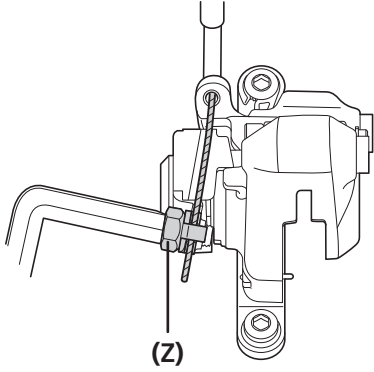
6	<p>If the cable loosens in step 5, tighten it by performing one of the following procedures.</p>		
	<p>For flat handlebar levers</p> 	<p>Turn the cable adjustment barrel counterclockwise to adjust the looseness in the cable, then manually tighten the cable adjustment nut if one is provided.</p>	<p>(Y) Cable adjustment nut (Z) Cable adjustment barrel</p>
	<p>For drop handlebar levers and triathlon levers</p> 	<p>Turn the cable adjustment barrel clockwise to adjust the looseness of the cable.</p>	<p>(Y) Outer casing (Z) Cable adjuster</p>
<p>When using a cable fixing bolt</p> 	<p>Loosen the cable fixing bolt, tighten the cable and then re-tighten the cable fixing bolt.</p>	<p>(Z) Cable fixing bolt</p>	

 **TECH TIPS**

If the stroke of the brake lever is too long:

If the stroke of the brake lever is too long even after the above adjustment, perform the following procedure.

A proper stroke can be set by reducing the initial pad clearances.

- Turn the pad adjustment screw clockwise to press the brake pads against the disc brake rotor before going on to step 2.
- With the brake pads pressed against the disc brake rotor, turn the pad adjustment screw counterclockwise one or two clicks.

ADJUSTMENT

ADJUSTMENT

■ Adjustment when the brake pads are worn

Adjust the clearances when the brake pads are worn down. Make sure to adjust the clearances on both the inboard side and outboard side at the same time.

Adjusting only one of the clearances may cause the following problems.

- Contact between the pads and the disc brake rotor may occur during operations other than braking.
- Sufficient braking force may not be obtained when the clearance becomes much greater on one side.
- The disc brake rotor makes contact with the calipers during braking.

Adjust both clearances between the disc brake rotor and brake pads (on the inboard side and outboard side) so that they are in the same range.

Inboard side 0.2mm - 0.4mm

Outboard side 0.2mm - 0.4mm

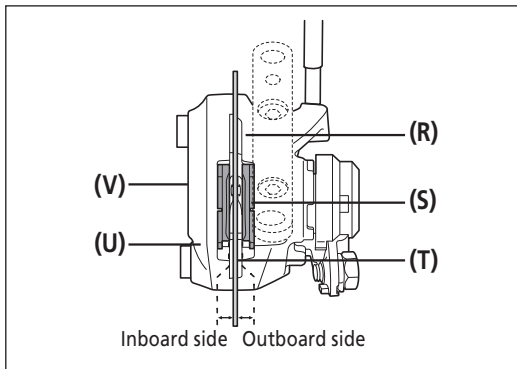

- (R) Rotor slit
- (S) Brake pad
- (T) Disc brake rotor
- (U) Caliper
- (V) Pad adjustment screw
- (W) Cable adjustment barrel
- (X) Cable adjustment nut
- (Y) Outer casing
- (Z) Cable adjuster



Adjusting the clearances on the inboard side and outboard side at the same time ensures that the brake pads can be used until they have reached a thickness of 0.5mm.

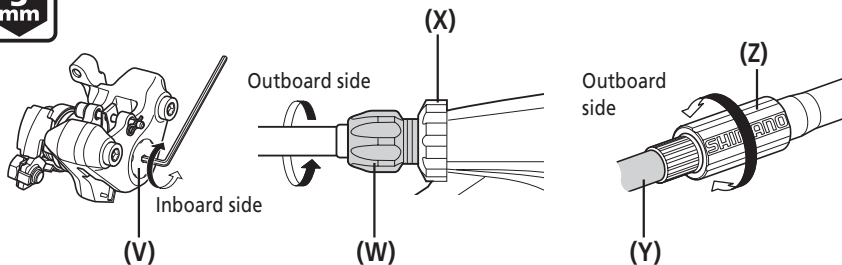

▶▶ Checking brake pad clearance and replacement timing

■ Checking brake pad clearance and replacement timing

If sufficient braking force cannot be obtained even when the brake levers are firmly depressed, or the reach of the brake levers does not change even when the tension of the brake cables is adjusted, perform the following checks.

Check that the arm is not making contact with the caliper while depressing the brake lever.

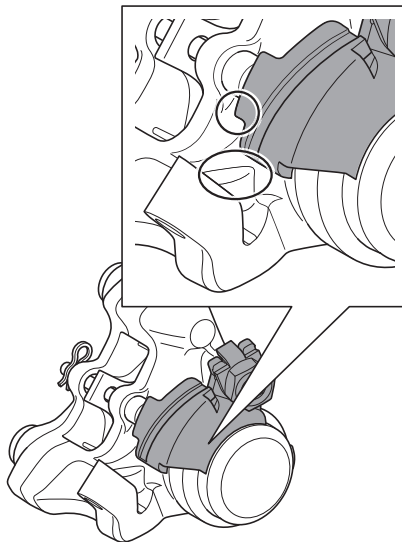

Arm is not in contact with caliper
(Normal condition)

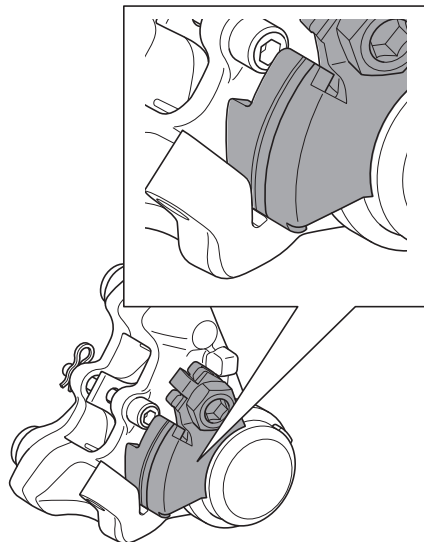

Arm is in contact with caliper
(Condition when clearance on the inboard side
needs adjusting or the brake pads need
replacing)

NOTE

Make sure that the temperature of the brake system has fallen sufficiently before performing the checks.

If the arm is making contact with the caliper, one or more of the following issues may be arising. Perform maintenance as appropriate.

Brake pad clearance on the inboard side is too large (the pad adjustment screw is not adjusted appropriately):

- Read the section "Adjustment when the brake pads are worn" under "ADJUSTMENT" and adjust the brake pad clearance on the inboard side.

The brake pads have reached a thickness of 0.5mm:

- It is time to replace the brake pads. Read the section "Replacing the brake pads" under "MAINTENANCE" and replace the brake pads with new ones.

MAINTENANCE

MAINTENANCE

■ Replacing the brake pads

Remove the wheel from the frame, and remove the brake pads as shown in the illustration.



1

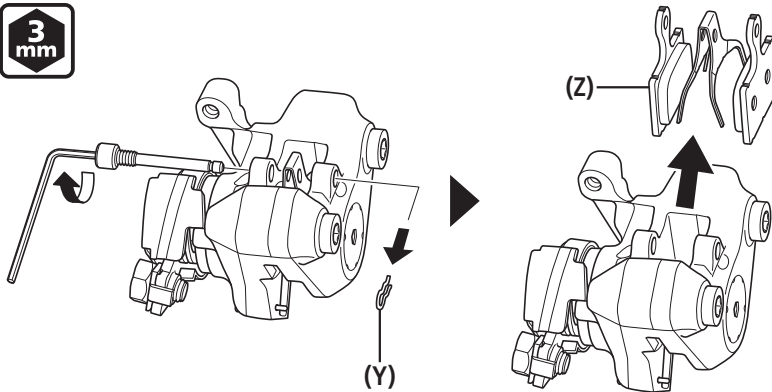

- (Y) Snap ring
- (Z) Brake pad

Loosen the pad adjustment screw by turning it counterclockwise.

Then, turn the cable adjustment barrels for the brake levers, or the cable adjusters, as indicated by the arrows.



2

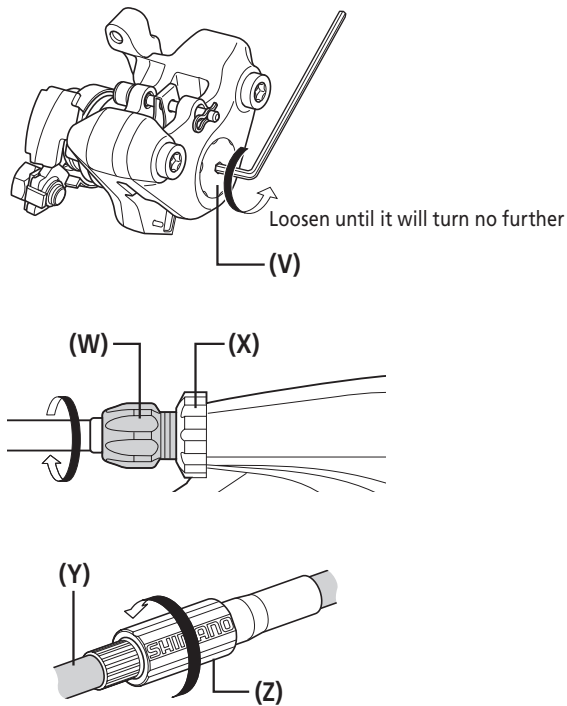

- (V) Pad adjustment screw
- (W) Cable adjustment barrel
- (X) Cable adjustment nut
- (Y) Outer casing
- (Z) Cable adjuster

▶▶ Replacing the brake pads

Install the new brake pads.

- At this point, make sure to install the snap ring as well.

3

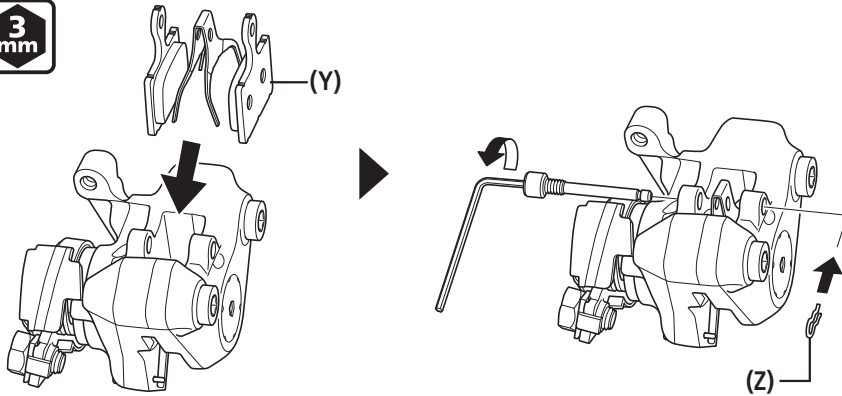

- (Y) Brake pad
- (Z) Snap ring

Tightening torque



2 - 4 N·m

Adjust both clearances between the disc brake rotor and brake pads (on the inboard side and outboard side) so that they are in the same range.

For details on adjusting pad clearance and the clearance on the outboard side, refer to the section "Adjustment when the brake pads are worn" under "ADJUSTMENT".

4

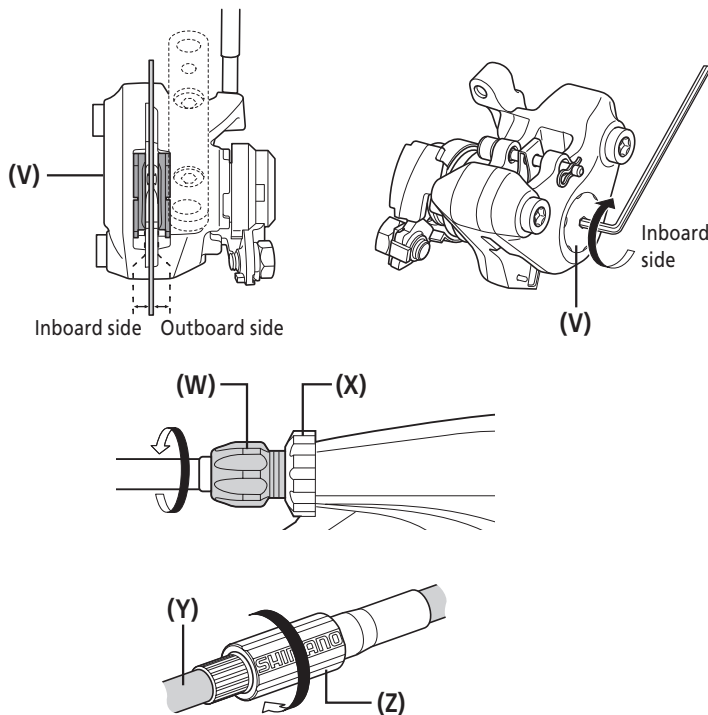

- (V) Pad adjustment screw
- (W) Cable adjustment barrel
- (X) Cable adjustment nut
- (Y) Outer casing
- (Z) Cable adjuster

5

After checking that the brake pad and the disc brake rotor are not touching each other, check that there are no problems when the brake lever is depressed.

SHIMANO

SHIMANO AMERICAN CORPORATION

One Holland, Irvine, California 92618, U.S.A. Phone: +1-949-951-5003

SHIMANO EUROPE B.V.

Industrieweg 24, 8071 CT Nunspeet, The Netherlands Phone: +31-341-272222

SHIMANO INC.

3-77 Oimatsu-cho, Sakai-ku, Sakai-shi, Osaka 590-8577, Japan

Please note: specifications are subject to change for improvement without notice. (English)

© Mar. 2016 by Shimano Inc. HTR