

Dealer's Manual

ROAD	MTB	Trekking
City Touring/ Comfort Bike	URBAN SPORT	E-BIKE

SPD-SL Pedal

DURA-ACE

PD-R9100

ULTEGRA

PD-R8000

SM-PD63

CONTENTS

IMPORTANT NOTICE.....	3
TO ENSURE SAFETY.....	4
LIST OF TOOLS TO BE USED.....	7
INSTALLATION	9
Cleat types	9
Attaching the cleats	10
When using the SM-SH20 cleat spacer (not included)	11
Adjusting cleat position.....	12
Mounting the pedals on the crank arms	13
MAINTENANCE	15
Adjusting the spring tension of the pedals.....	15
Cleat replacement.....	16
Axle unit	16
Mounting the reflectors	20

IMPORTANT NOTICE

- **This dealer's manual is intended primarily for use by professional bicycle mechanics.**

Users who are not professionally trained for bicycle assembly should not attempt to install the components themselves using the dealer's manuals. If any part of the information on the manual is unclear to you, do not proceed with the installation. Instead, contact your place of purchase or a local bicycle dealer for their assistance.

- Make sure to read all instruction manuals included with the product.
- Do not disassemble or modify the product other than as stated in the information contained in this dealer's manual.
- All dealer's manuals and instruction manuals can be viewed on-line on our website (<http://si.shimano.com>).
- Please observe the appropriate rules and regulations of the country, state or region in which you conduct your business as a dealer.

For safety, be sure to read this dealer's manual thoroughly before use, and follow it for correct use.

The following instructions must be observed at all times in order to prevent personal injury and physical damage to equipment and surroundings. The instructions are classified according to the degree of danger or damage which may occur if the product is used incorrectly.



Failure to follow the instructions will result in death or serious injury.



Failure to follow the instructions could result in death or serious injury.



Failure to follow the instructions could cause personal injury or physical damage to equipment and surroundings.

TO ENSURE SAFETY

WARNING TO PARENT/GUARDIAN

- For child safety, make sure the child uses this product correctly by following the instructions below. Both guardians and children should gain an adequate understanding of the content of this manual. Failure to follow the provided instructions may lead to serious injury.

WARNING

- **Be sure to follow the instructions provided in the manuals when installing the product.**
It is recommended to use genuine Shimano parts only. If parts such as bolts and nuts become loose or damaged, the bicycle may suddenly fall over, which may cause serious injury.
In addition, if adjustments are not carried out correctly, problems may occur, and the bicycle may suddenly fall over, which may cause serious injury.
-  Be sure to wear safety glasses or goggles to protect your eyes while performing maintenance tasks such as replacing parts.
- After reading the dealer's manual thoroughly, keep it in a safe place for later reference.

Be sure to also inform users of the following:

If the warnings below are not followed, your shoes may not come out of the pedals when you intend or they may come out unexpectedly or accidentally, and severe injury may result.

- SPD pedals are designed to be released only when intended. They are not designed to be released automatically when you have fallen off the bicycle.
- Before attempting to ride with these pedals and shoes, make sure you understand the operation of the engagement/release mechanism for the pedals and cleats (shoes).
- Before you attempt to ride with these pedals and shoes, apply the brakes, then place one foot on the ground and practice engaging and releasing each shoe from its pedal until you can do so naturally and with minimal effort.
- Ride on level ground first until you become accustomed to engaging and releasing your shoes from the pedals.
- Before riding, adjust the spring tension of the pedals to your liking. If the spring tension of the pedals is low, the cleats may become accidentally released and you may lose balance and fall off the bicycle. If the spring tension of the pedals is high, the cleats cannot be easily released.
- When riding at low speed or when there is a possibility that you might need to stop riding, (for example, when doing a U-turn, nearing an intersection, riding uphill or turning a blind curve), release your shoes from the pedal beforehand so that you can quickly put your feet onto the ground at any time.
- Use a lighter spring tension for attaching the pedal cleats when riding in adverse conditions.
- Keep cleats and bindings out of dirt and debris to ensure proper engagement and release.
- Remember to check the cleats periodically for wear. When the cleats are worn, replace them, and always check the spring tension before riding and after replacing the pedal cleats.
- Do not continue riding the bicycle if the reflectors are dirty or damaged. Otherwise, it becomes more difficult for others to see you.
- Use only SPD-SL shoes with this product. Other types of shoe may not release from the pedals, or may release unexpectedly.
- Use only Shimano cleats (SM-SH10/SM-SH11/SM-SH12) and make sure that the mounting bolts are tightened securely to the shoes.
- Be sure to attach reflectors to the bicycle when traveling on public roads.

■ SM-SH20 Cleat spacer

- This cleat spacer is designed to adjust the lengths of both the left and right legs when Shimano cleats are installed to Shimano road racing shoes. Never use other combinations.
- The cleats that are compatible with this cleat spacer are SM-SH10, SM-SH11, and SM-SH12.
- Also refer to the user's manuals for the applicable shoes and pedal before installing this cleat spacer to a shoe.

NOTE**Be sure to also inform users of the following:**









- Check that there is no looseness in any joints or connections before riding the bicycle.
- Check that there is no looseness in the cleats or spacers before riding the bicycle.
- If pedaling performance does not feel normal, check the bicycle once more.
- If you experience any trouble with the rotating parts of the pedal, the pedal may require adjustment. Consult a dealer or an agency.
- Be sure to retighten the crank arms and pedals at periodic intervals at the place of purchase or a bicycle dealer.
- Products are not guaranteed against natural wear and deterioration from normal use and aging.
- For maximum performance we highly recommend Shimano lubricants and maintenance products.

The actual product may differ from the illustration because this manual is intended mainly to explain the procedures for using the product.

LIST OF TOOLS TO BE USED

LIST OF TOOLS TO BE USED

The following tools are needed for installation, adjustment, and maintenance purposes.

Tool		Tool		Tool	
	2.5mm hexagon wrench		7mm spanner		20mm spanner
	4mm hexagon wrench		10mm spanner		Screwdriver[#2]
	8mm hexagon wrench		17mm spanner		

INSTALLATION

INSTALLATION

■ Cleat types

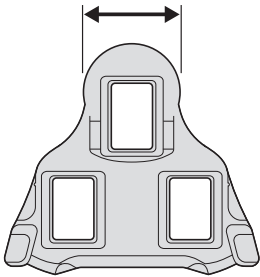
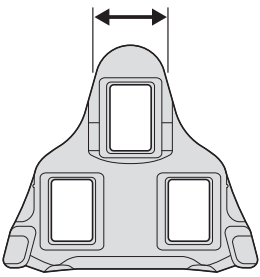
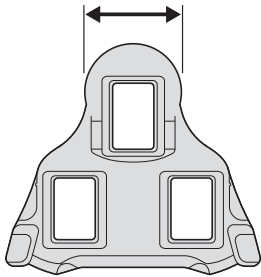
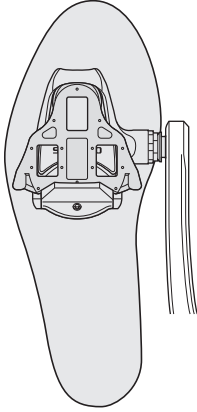
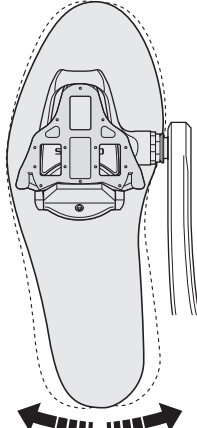
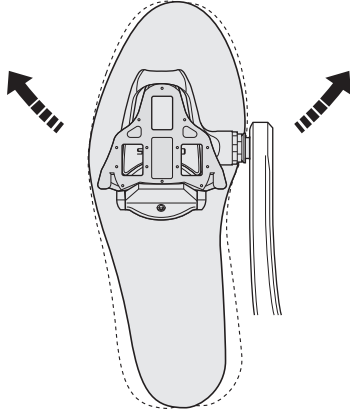
SM-SH10	SM-SH11 (PD-R8000: standard)	SM-SH12 (PD-R9100: standard)
Red	Yellow	Blue
<p>Wide</p> 	<p>Narrow</p> 	<p>Wide</p> 
<p>Fixed mode There is no looseness when the shoes are firmly engaged with the pedals. There is no looseness.</p> 	<p>Self-aligning mode There is some sideways looseness when the shoes are engaged with the pedals.</p> 	<p>Front center pivot mode There is some sideways looseness centered on the front of the shoes.</p> 

■ Attaching the cleats

Set the cleat on the bottom of each shoe as shown in the illustration, and then tighten the cleat mounting bolts, temporarily.

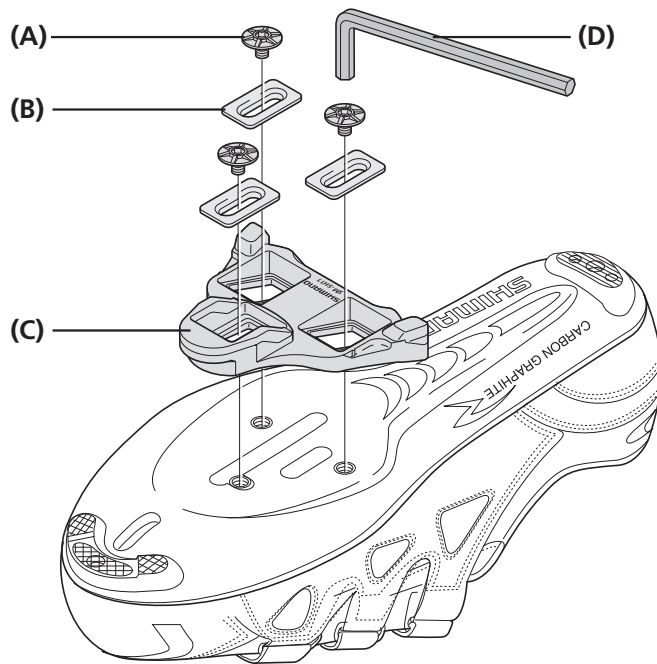

- (A) Cleat mounting bolt
- (B) Cleat washer
- (C) Cleat
- (D) 4mm hexagon wrench

NOTE

When installing the cleat, use the cleat washer and the cleat mounting bolt included with the Shimano pedal. If other cleat mounting bolts are used, the cleat mounting section may become damaged.

▶▶ When using the SM-SH20 cleat spacer (not included)

■ **When using the SM-SH20 cleat spacer (not included)**

Temporarily attach the cleat spacer and the cleat from the back side of the shoe in the order indicated in the illustration.

Use the bolt of the appropriate length for the adjustment range in accordance with the following table. The range for adjustment is 1 - 5mm.

Stack the 1mm and 2mm cleat spacers when attaching.

Adjustment range	1mm Cleat spacer	2mm Cleat spacer	Proper bolt
1mm	1	-	Standard or M
2mm	-	1	M
3mm	1	1	M or L
4mm	-	2	L
5mm	1	2	L

Bolt sizes Standard: 8mm M: 10mm L: 13.5mm

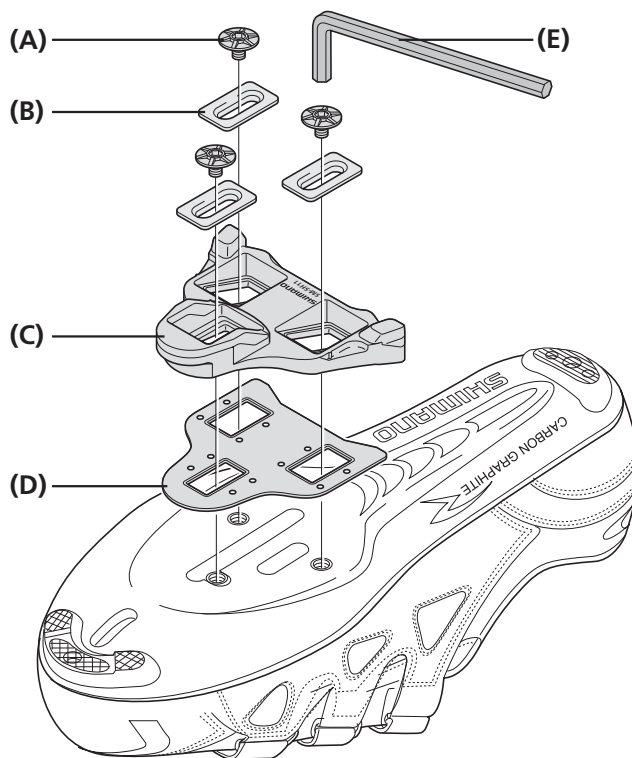

- (A) Cleat mounting bolt
- (B) Cleat washer
- (C) Cleat
- (D) Cleat spacer
- (E) 4mm hexagon wrench

NOTE

- When installing the cleat, use the dedicated cleat mounting bolt (standard bolt included with the pedal or the medium or long bolt included with SM-SH20) and the cleat washer included with the pedal.
- If a bolt of inappropriate length is used, the bolt may not reach the nut or the mounting section of the cleat may become damaged.

■ Adjusting cleat position

1

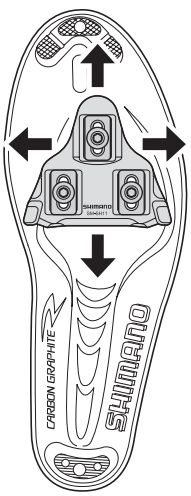

The cleat has an adjustment range of 11mm front to back and 5mm right to left.

If the cleat nut stoppers (plastic) are removed from the sole, the front to back adjustment range increases to 22mm.

After temporarily fixing the cleats, adjust them by repeatedly engaging and releasing the cleats, one by one, to determine the optimal necessary cleat positions.

2

After the optimal cleat positions have been determined, firmly tighten the cleat mounting bolts with a 4mm hexagon wrench.

Tightening torque	
	5 - 6 N·m

■ Mounting the pedals on the crank arms

1 Apply a small amount of grease to the thread to prevent sticking.

2

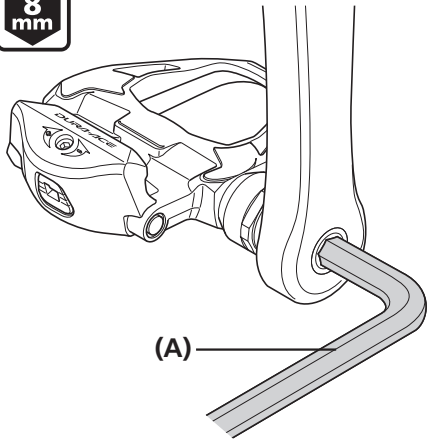

Use an 8mm hexagon wrench to install the pedals to the cranks.

(A) 8mm hexagon wrench

Tightening torque



35 - 55 N·m

TECH TIPS

Pay attention to the difference between the left and right pedals.

Right pedal	Left pedal
No notch in end of screw stem	Notch in end of screw stem
Right-hand thread	Left-hand thread

3 Remove any roughness or bumps on the joint, if detected.

MAINTENANCE

MAINTENANCE

■ Adjusting the spring tension of the pedals

Adjust the spring force to the optimal cleat holding force as needed when releasing the cleats from the bindings.

Turn the adjustment bolt located at the rear of each binding to adjust the spring tension of the bindings.

Clicking the adjustment bolt changes the tension one step. There are four clicks per turn.

Turning the adjustment bolt clockwise increases the spring tension, and turning it counterclockwise decreases it.

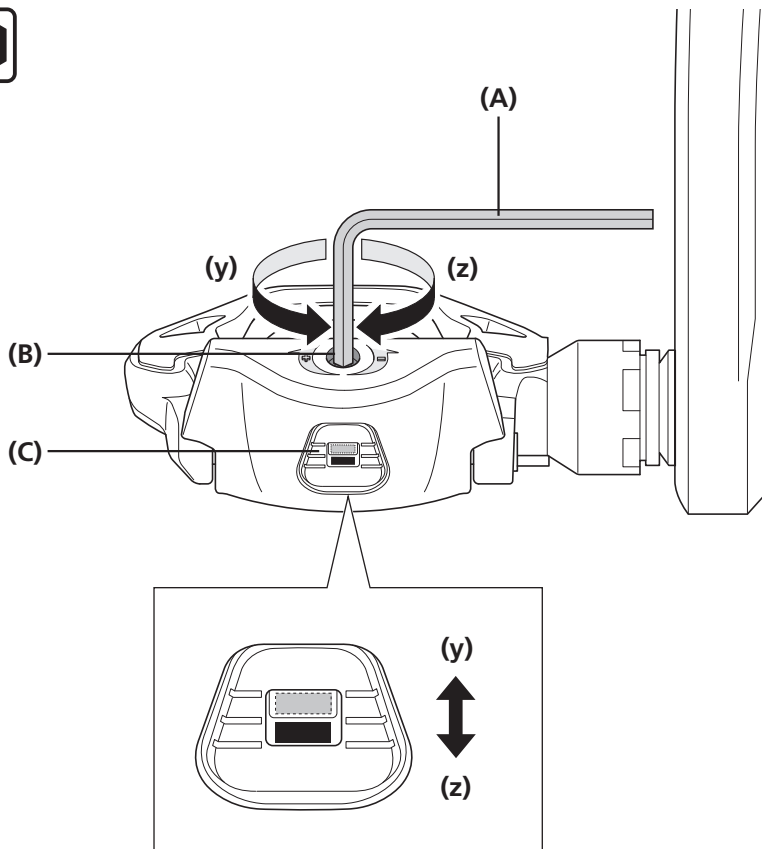

(y) Decrease

(z) Increase

(A) 2.5mm hexagon wrench

(B) Adjustment bolt

(C) Indicator

NOTE

- Do not turn the bolt past the point at which the indicator shows the maximum or minimum tension.
- In order to prevent accidental shoe release and ensure that release is possible when needed, make sure all spring tensions are properly adjusted.
- If the cleats are not adjusted equally, it can cause the rider difficulty in engaging or releasing the pedals. The spring tensions for the right and left pedals should be adjusted so they are equal.
- Equalize the spring tensions for both pedals by referring to the tension indicators and by counting the number of turns of the adjustment bolts.

■ Cleat replacement

Cleats become worn and need to be replaced periodically. Cleats should be replaced when it becomes heavy for the rider to release, or it starts to release with much less effort than that when it was in new condition.

NOTE

If the colored portion of the cleat becomes worn, replace it with a new one.

- Front: Replace the cleats when the black layer underneath the cleats is visible.
- Rear : Replacement is required once the cleat has worn down to the level of the replacement reference line.

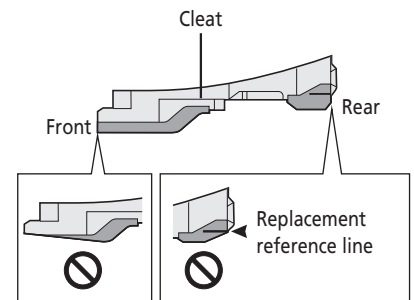

■ Axle unit

Adjustment is required if the rotating parts are not functioning properly. Follow the procedure shown below.

PD-R9100

Removing the axle

1 Loosen the lock nut using a 20mm spanner such as TL-HS40.

2 Loosen the threaded cone using a 17mm spanner such as TL-HS37 and remove the axle.

Remove the balls (9 pcs.) inside the pedal body.

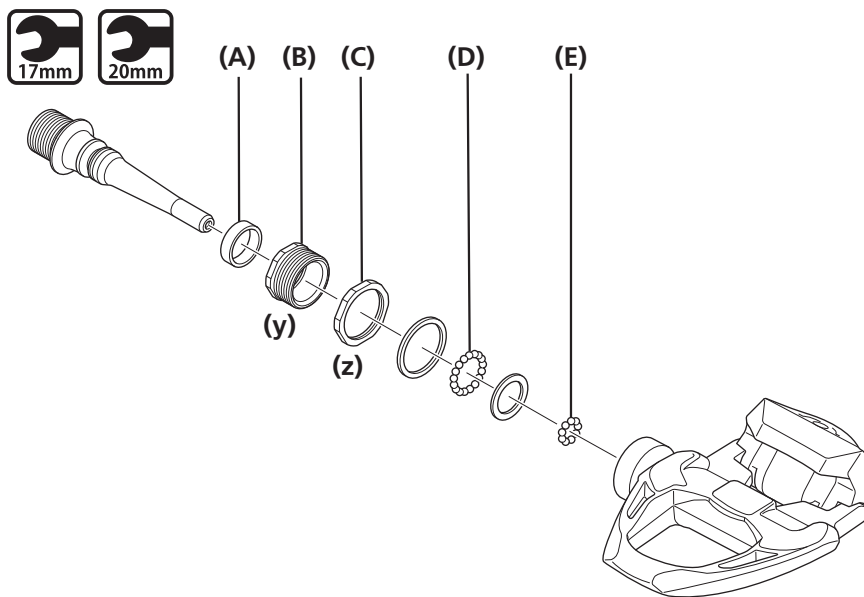

(y) 17mm spanner

(z) 20mm spanner

(A) Rubber seal

(B) Threaded cone

(C) Lock nut

(D) Balls (17 pcs.)

(E) Balls (9 pcs.)

NOTE

Both the lock nut and the threaded cone are threaded left-hand for the right pedal and right-hand for the left pedal.

Assembling the axle

1 Put the balls (9 pcs.) into the holes of the pedal body, and then inject about 0.9 g of grease.

2 Install the parts to the axle as shown in the figure, and apply grease on the tip of the axle and the threaded cone.

Combine [1] and [2].

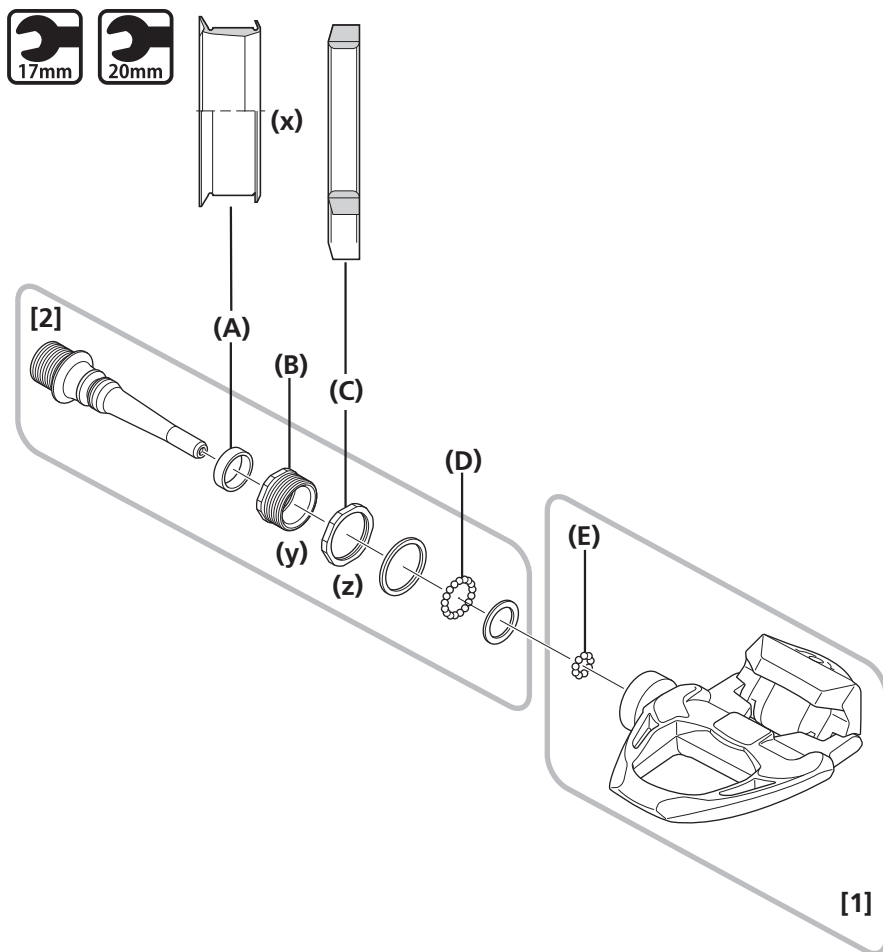

(x) When assembling the rubber seal and lock nut, please note the direction of the parts.

(y) 17mm spanner

(z) 20mm spanner

(A) Rubber seal

(B) Threaded cone

(C) Lock nut

(D) Balls (17 pcs.)

(E) Balls (9 pcs.)

NOTE

- Clean off old grease.
- Both the lock nut and the threaded cone are threaded left-hand for the right pedal and right-hand for the left pedal.

Adjustment of axle rotation

1 Turn the threaded cone by using a 17mm spanner to adjust rotation.

2 With the threaded cone fixed, tighten the lock nut (20mm).

Tightening torque



10 - 15 N·m

NOTE

Adjust so as to achieve a smooth rotation without looseness when the axle unit is set into the pedal.

PD-R8000

1 Loosen the lock bushing and remove the axle unit.

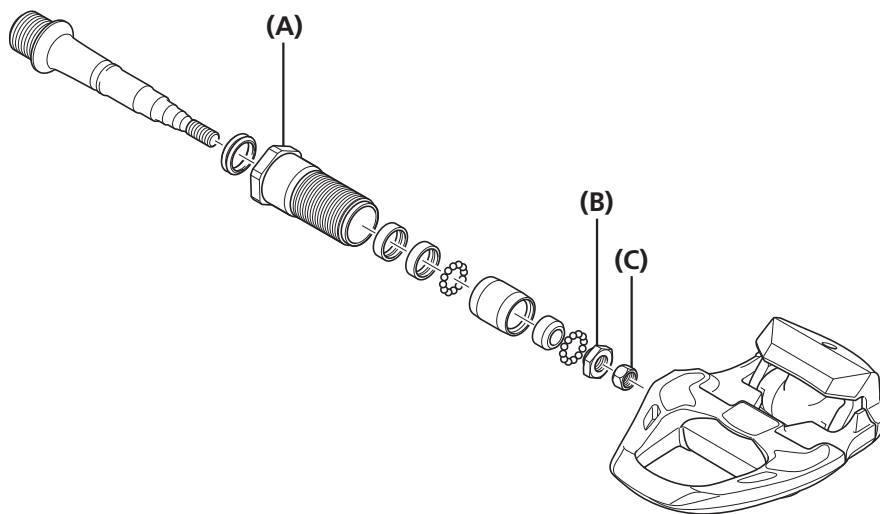

- (A) Lock bush
- (B) Cone
- (C) Lock nut

NOTE

The lock bush of the right pedal has a left-hand thread; the lock bush of the left pedal has a right-hand thread.

2 Use TL-PD63 or TL-PD33 Shimano original tool, or a 7mm or 10mm open wrench to turn the cone (10mm) to adjust the rotation.

3

With the cone locked, tighten the lock nut (7mm).

Tightening torque	
	5 - 7 N·m

NOTE

- Right-hand thread: Black-colored (without slit)
If the fitted lock nut is black-colored (without slit), the cone and the lock nut have a right-hand thread.



- Left-hand thread: Black-colored (with slit), Silver-colored
If the fitted lock nut is silver-colored or black-colored (with slit), the cone and the lock nut have a left-hand thread.



- Adjust the cone so as to achieve a smooth rotation without looseness when the axle unit is set into the pedal.

 **TECH TIPS**

The rotating parts are fastened when the axle unit is set into the pedal. Adjust them slightly loosely before setup.

4

Remove old grease and apply an appropriate amount of new grease to the bottom of the pedal linkage.

 **TECH TIPS**

Apply grease to the extent that it does not flow out when the axle is set into the pedal (about 1.5g).

▶ Mounting the reflectors

5

Tighten the lock bush and insert the axle unit.

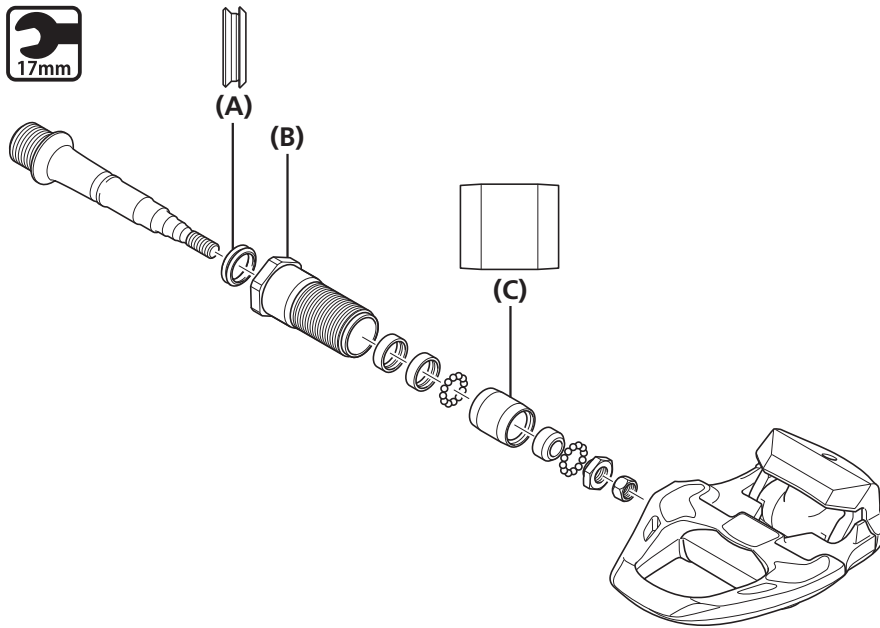

- (A) Rubber seal
- (B) Lock bush
- (C) Body cup

Tightening torque	
	10 - 12 N·m

NOTE

When assembling the rubber seal, please note the direction of the parts.

■ Mounting the reflectors

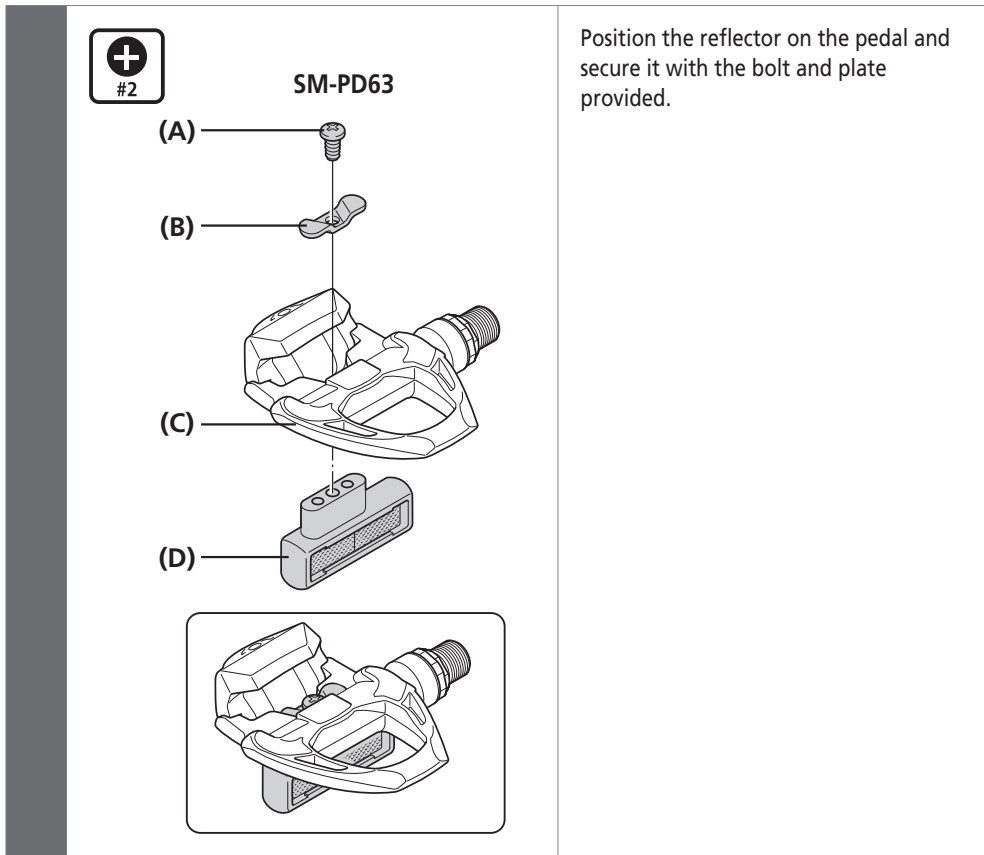

Position the reflector on the pedal and secure it with the bolt and plate provided.

- (A) Bolt
- (B) Plate
- (C) Pedal
- (D) Reflector

Tightening torque	
	2 N·m

 **TECH TIPS**

The illustration shows the right pedal.

SHIMANO

SHIMANO AMERICAN CORPORATION

One Holland, Irvine, California 92618, U.S.A. Phone: +1-949-951-5003

SHIMANO EUROPE B.V.

High Tech Campus 92, 5656 AG Eindhoven, The Netherlands Phone: +31-402-612222

SHIMANO INC.

3-77 Oimatsu-cho, Sakai-ku, Sakai-shi, Osaka 590-8577, Japan

Please note: specifications are subject to change for improvement without notice. (English)

© Feb. 2017 by Shimano Inc. ITP