

User's Manual

SHIMANO STEPS Special Battery and Parts

Check our website for the latest manuals.
<https://si.shimano.com>



Contents

IMPORTANT NOTICE	4
Important safety information	5
SHIMANO STEPS battery management systems and compatibility	11
Notice	12
Regular inspections before riding the bicycle	15
Handling method	16
Handling the battery	16
Booklet structure	18
Names of parts	19
Names of battery charger parts	19
Names of satellite charging port parts	19
Main specifications	21
Battery specifications	21
Battery charger specifications	21
Charging the battery	22
Designated charging time	22
Charging the battery removed from the bicycle	22
Charging the battery attached to the bicycle	24
Battery charger LED	26
Battery LED	27
Installing the battery	30
Installing the battery	30
Removing the battery	33
Removing the battery.....	33
Power ON/OFF	38
Power ON/OFF	38
Troubleshooting	40
When a problem occurs.....	40

Battery LED error indications41



IMPORTANT NOTICE

- Contact the place of purchase or a distributor for information on installation and adjustment of the products which are not found in the user's manual. A dealer's manual for professional and experienced bicycle mechanics is available on our website (<https://si.shimano.com>).
- Do not disassemble or modify the product.
- Please observe the appropriate rules and regulations of the country, state or region in which you conduct your business as a dealer.
- Also, read the SHIMANO STEPS user's manual.

 For safety, be sure to read this user's manual thoroughly before use, follow it for correct use, and store it so that it can be referenced at any time.



The following instructions must be observed at all times in order to prevent personal injury and physical damage to equipment and surroundings.

The instructions are classified according to the degree of danger or damage which may occur if the product is used incorrectly.

	DANGER	Failure to follow the instructions will result in death or serious injury.
	WARNING	Failure to follow the instructions could result in death or serious injury.
	CAUTION	Failure to follow the instructions could cause personal injury or physical damage to equipment and surroundings.



Important safety information

- Symbols that may be on the product are described below.

	For information on the replacement procedure, contact the place of purchase or distributor.
	Be sure to observe the following instructions in order to avoid burns or other injury from fluid leakage, overheating, fire, or explosion.

DANGER

■ Handling the battery

- Use the specified battery charger for charging and observe the specified charging conditions.
Doing otherwise may cause overheating, bursting, or ignition.
-  Do not leave the battery near sources of heat such as heaters, and do not heat the battery or throw it into a fire.
Doing so may cause bursting or ignition.
-  Do not deform, modify, disassemble, or apply solder directly to the battery.
Doing so may cause leakage, overheating, bursting, or ignition.
- Do not connect the (+) and (-) terminals with metallic objects. Do not carry or store the battery together with metallic objects such as necklaces or hairpins.
If this is not observed, short-circuits or overheating may occur, resulting in burns or other injury.
- Do not place the battery into fresh water or sea water, and do not allow the battery terminals to get wet.
Doing so may cause overheating, bursting, or ignition.
- Do not throw or subject the battery to strong shock.
Doing so may cause overheating, bursting, or ignition.

■ Handling the battery charger

- Use the specified battery and battery charger combination for charging and observe the specified charging conditions.
Only charge rechargeable batteries.
Doing otherwise may cause overheating, bursting, or ignition.
- If the battery does not become fully charged even 2 hours after the designated charging time, immediately unplug the battery from the electrical outlet and contact the place of purchase.
Doing otherwise may cause overheating, bursting, or ignition.
Refer to "Designated charging time."
- Do not allow the battery charger to get wet.
If it is wet or water is allowed inside, it could cause a fire, ignition, overheating, or electric shock.
- Do not use it while it is wet, and do not touch or hold it with wet hands.
An electric shock may occur.
- Do not use the battery charger when it is covered with a cloth or other material.
If this is not observed, heat may build up and the case may become deformed, or fire, ignition, or overheating may occur.
- Do not disassemble or modify the battery charger.
If this is not observed, electric shocks or injury may occur.

Important safety information

- Use the battery charger at the specified power supply voltage only.
If a power supply voltage other than that specified is used, fire, destruction, smoke, overheating, electric shocks or burns may occur.

WARNING

-  Do not insert or remove the plug while it is wet.
Doing so may result in electric shock. If the inside of the plug is wet, dry it thoroughly before inserting it.
- Do not recharge the battery in wet or very humid places. (EC-E8004)
Do not recharge the battery in wet or very humid places, or outdoors. (EC-E6002)
A fire, ignition, overheating, or electric shock may occur.
- Handling the battery
 - If any liquid leaking from the battery gets into your eyes, immediately wash the affected area thoroughly with clean water such as tap water without rubbing your eyes, and seek medical attention immediately.
If this is not done, the battery liquid may damage your eyes.
 - Do not use the battery outside its operating temperature ranges.
If a battery is used or stored in temperatures which are outside these ranges, fire, injury or problems with operation may occur. The operating temperature ranges are given below:
 - (1) During discharge: -10 - 50°C
 - (2) During charging: 0 - 40°C
 - Do not use the battery if it has any noticeable scratches or other external damage.
If this is not observed, bursting, overheating or problems with operation may occur.
 - Do not use the battery if leakages, discoloration, deformation, or any other abnormalities occur.
If this is not observed, bursting, overheating or problems with operation may occur.
- Handling the battery charger
 - Be sure to hold the power plug when connecting or disconnecting from the electrical outlet.
Failure to do so may cause a fire or electric shock. If the following symptoms are observed, stop using the device and contact the place of purchase. A fire or electric shock may be caused.
 - * If heat, acrid-smell, or smoke is coming out from the power plug.
 - * There may be a bad connection inside the power plug.
 - Do not touch the metallic parts of the device or the power plug on the AC adapter or other parts if there is a lightning storm.
If lightning strikes, electric shocks may occur.
 - Do not overload the electrical outlet with appliances beyond its rated capacity, and use only a 100 - 240 V AC electrical outlet.
If the electrical outlet is overloaded by connecting too many appliances using adapters, overheating resulting in fire may occur.

Important safety information

- Do not damage the power cord or power plug. (Do not damage, process, forcibly bend, twist or pull them, bring them near hot objects, place heavy objects on them or bundle them tightly together.)
If they are used while damaged, fire, electric shocks or short-circuits may occur.
- Do not use the battery charger with commercially-available electrical transformers designed for overseas use (travel converters).
They may damage the battery charger.
- Always be sure to insert the power plug as far as it will go.
If this is not observed, fire may occur.
- When charging the battery while it is installed on the bicycle, do not move the bicycle.
The battery charger's power plug may come loose and not be fully inserted into the electrical outlet, resulting in a risk of fire.

CAUTION

■ Handling the battery

- Do not leave the battery in a place exposed to direct sunlight, inside a vehicle on a hot day, or other hot places.
This may result in battery leakage.
- If any leaked fluid gets on your skin or clothes, wash it off immediately with clean water.
The leaked fluid may damage your skin.
- Keep away from children.
- Handle components with both hands.
Failure to do so may cause the components to fall and break or cause injury.
- If an error occurs during the battery discharge or charge operation, immediately stop using it and check the user's manual.
If you are not sure, consult the place of purchase or a distributor.
-  Do not touch the battery when it is at a high temperature. Doing so may cause a burn.
- Do not touch the battery for an extended period of time when its temperature has increased. Doing so may cause a low-temperature burn.

■ Handling the battery charger

- When performing cleaning, disconnect the power plug from the electrical outlet and the charging plug from the battery.
If this is not observed, an electric shock may occur.
-  Do not touch the battery charger when it is at a high temperature. Doing so may cause a burn.
- Do not let the battery touch the same area of skin for an extended period of time while it is charging. The temperature may reach 40 to 70°C while charging, which can cause low-temperature burns.
- Periodically check the battery charger and adapter, particularly the cord, plug, and case, for any damage.
If the battery charger or adapter is broken, do not use it until it has been repaired by the place of purchase or a distributor.
- Use the product under the supervision of someone responsible for safety, and only as instructed.
Do not allow anyone (including children) with reduced physical, sensual, or mental capacity, or those without experience or knowledge, to use the product. Do not allow children to play near the product.

SHIMANO STEPS battery management systems and compatibility

There are two generations of the SHIMANO STEPS battery management system: first generation and second generation (Gen.2).

This manual only describes products compatible with Gen.2.

With some exceptions, first-generation and Gen.2 products of SHIMANO STEPS components are not compatible with each other. For details, refer to the compatibility information on the SHIMANO product website (<https://productinfo.shimano.com/#/com>).

The Gen.2 battery and compatible battery mount are marked "Gen.2" as indicated in the figure.

Location of terminals

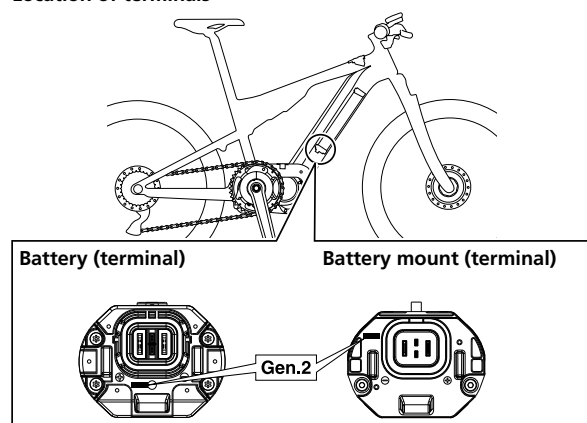

Notice

Charging can be carried out at any time, regardless of the remaining battery, but please fully charge the battery in the following case. Be sure to use the dedicated battery charger.

- The battery is not fully charged at the time of purchase. Before riding, be sure to fully charge the battery. The battery can be used when its LED turns on.
- When the battery is completely depleted, charge it as soon as possible. If you leave the battery without charging it, the battery will deteriorate and may become unable to be used.

■ Handling the battery

- Wait a while before pressing the power button when turning the power ON again after the power has been turned OFF.
- Before connecting the battery, make sure that the area where the battery will be connected (terminal) is dry and not dirty.
- Press the battery power button and if the LED display does not light up, the protective circuit is operating. Connect the battery charger and charge the battery to deactivate this.
- If the battery is charged in a low-temperature environment of 5°C or lower, the traveling distance of a full charge will be shorter. Also, if the battery is used in a low-temperature environment of 5°C or lower, the battery consumption will become quicker. This is due to the characteristics of the battery, and the battery will return to normal when at a normal temperature.
- Riding with a high level of assistance in a low-temperature environment when the battery level is low may cause the battery level to drop to 0%, due to the characteristics of the battery. Charge it before use.

■ Handling the battery charger

- The battery can be charged at temperatures between 0°C - 40°C. The battery charger will not operate at temperatures outside the range. It will display an error. (The battery charger LED flashes.)
- Do not use in environments with high humidity. (EC-E8004)
- Do not use outdoors or in environments with high humidity. (EC-E6002)
- Charge the battery in a location not exposed to rain or wind. (EC-E8004)
-  Charge the battery indoors to avoid exposure to rain or wind. (EC-E6002)
- Do not place the battery charger on dusty floors when using it.
- Place the battery charger on a stable surface such as a table when using it.
- Do not place any objects on top of the battery charger or its cable. Also, do not cover it with a cover or other object.

Notice

- Do not bundle the cables.
- Do not hold the battery charger by the cables when carrying it.
- Do not apply excessive tension to the cable and charging plug.
- In order to prevent the cable from being damaged, avoid wrapping it around the battery charger during storage.
- Do not wash the battery charger or wipe it using detergents.
- Do not allow children to play near the product.
- When charging with the battery installed to a bicycle, take care that your legs, etc. do not get caught in the battery charger cord. Doing otherwise may cause injury or cause the bicycle to fall over and break the components.
- When charging the battery while it is mounted on the bicycle, be careful of the following:
 - Before charging, check that there is no water on the charging port of the charging plug.
 - Check that the battery mount is locked before charging.
 - Do not remove the battery from the battery mount while charging.
 - Do not ride with the battery charger mounted.
 - Close the cap on the charging port when not charging.
 - Fix the bicycle in place when charging, so that it does not tip over.
- Make sure to close the charging port cap after charging is complete. If foreign material such as dirt or dust is adhering to the charging port, it may not be possible to insert the charging plug.
- Using the battery outside the operating temperature range may cause problems with operation or performance degradation.
- The charging time is longer when the battery temperature is high.

■ Care and maintenance

- The number written on the key of the battery mount is necessary when purchasing a spare key. Store it carefully.
- Do not use thinner or other solvents to clean any of the components. Such substances may damage the surface.
- When there is dirt on the terminals of the battery mount and battery charger, remove the battery, remove the power plug from the electrical outlet, then clean them with a clean rag or cotton bud dampened with ethanol, etc. If you repeatedly install and remove the battery while they are still dirty, it may cause wear on the terminals and make them unable to be used.

Terminal example

Notice



- Keep the surface where the battery contacts the battery mount clean. If the battery is connected with foreign material such as dirt or dust attached, the battery may become unable to be removed.



- Use a damp, well wrung out cloth, when cleaning the battery and plastic cover.
- For any questions regarding methods of installation and maintenance, please contact your place of purchase.
- Products are not guaranteed against natural wear and deterioration from normal use and aging.
- For maximum performance we highly recommend SHIMANO lubricants and maintenance products.

Regular inspections before riding the bicycle

Before riding the bicycle, check the following items. If any problems are found, consult your place of purchase or a distributor.

- Is the battery level sufficient?
- Is the battery installed correctly?

Handling method

Handling the battery

Designated charging time

The charging time will vary depending on the battery level and the battery charger being used. Refer to “ Designated charging time .”

The SHIMANO STEPS special battery is a lithium-ion battery. Use the dedicated battery charger designated by SHIMANO.

Battery storage method

- If the bicycle will not be ridden for an extended period, store it with a battery level of approximately 70%. Also, charge the battery once every six months to ensure that it is not completely discharged.
- Store the battery or bicycle with battery installed in a cool indoor location away from direct sunlight and rain (approx. 10 to 20°C). If the storage temperature is too low or too high, the performance of the battery is reduced, and its usable time will be shorter. When you use it after a long storage period, make sure to charge it first.

Battery life

- The battery is an exhaustible item. The battery will gradually lose its capacity to charging after repeated use. If the length of time that the battery can be used and its traveling distance become extremely short, you will need to purchase a new battery.
- The life of the battery will vary depending on factors such as the storage method, the usage conditions, the surrounding environment and the characteristics of the individual battery pack.

Used batteries

Lithium-ion batteries are recyclable, valuable resources.

Please observe the appropriate rules of the country, state or region regarding the disposal of used batteries. If

Handling method

Handling the battery

you are not sure, consult the place of purchase or distributor.

Labels

Some of the important information contained in this user's manual is also indicated on the device label.

This device complies with part 15 of the FCC Rules. Operation is subject to the following two conditions:
(1) This device may not cause harmful interference, and (2) this device must accept any interference received, including interference that may cause undesired operation.



Disposal information for countries outside the European Union

This symbol is only valid within the European Union. Follow local regulations when disposing of used batteries. If you are not sure, consult the place of purchase or distributor.



This symbol on your product, literature, or packaging reminds you that this product must be taken to separate collection at the end of its working life. Do not dispose of this product as unsorted municipal waste but instead take it for recycling. By ensuring the product is disposed correctly, you will help to prevent potential negative consequences for the environment and human health. For info on your nearest recycling point, check with your local waste authority.

Booklet structure

SHIMANO STEPS user's manuals are split among several booklets, as described below.

Be sure to read these user's manuals thoroughly before use, and follow them for correct use. Store the user's manuals so that they can be referenced at any time.

The latest user's manuals are available on our website (<https://si.shimano.com>).

Name	Details
SHIMANO STEPS User's Manual	This is the basic user's manual for SHIMANO STEPS. It contains the following content: <ul style="list-style-type: none"> • SHIMANO STEPS quick guide • Basic operations when riding • How to operate assist bicycles that use flat handlebars, such as city, trekking, or MTB type bicycles
SHIMANO STEPS User's Manual for Drop Handlebar Bicycles (separate booklet)	This booklet describes how to operate assist bicycles that use a drop handlebar and are controlled using dual control levers. This should be read along with the SHIMANO STEPS User's Manual.
SHIMANO STEPS Special Battery and Parts User's Manual (Gen.2)	It contains the following content: <ul style="list-style-type: none"> • How to charge and handle the SHIMANO STEPS special battery • How to attach and remove the SHIMANO STEPS special battery to the bicycle • How to read the battery LEDs when charging or during an error
SHIMANO STEPS Cycle Computer User's Manual (clamp band type / bracket installation type / switch unit integrated type)	It contains the following content: <ul style="list-style-type: none"> • Method for configuring settings via the main body buttons and switch unit • Wireless communication method (supported models only)
Switch Unit User's Manual (with LED indicator function / without LED indicator function)	This is the assist switch and shift switch user's manual. It describes switch unit handling and operations.
Satellite System ON/OFF Switch User's Manual	It describes the handling and operations of the satellite system ON/OFF switch.

Names of parts

Names of battery charger parts

The EC-E6002 requires a power cord (SM-BCC1) that is sold separately. Insert the SM-BCC1 in firmly as far as it will go.

EC-E6002

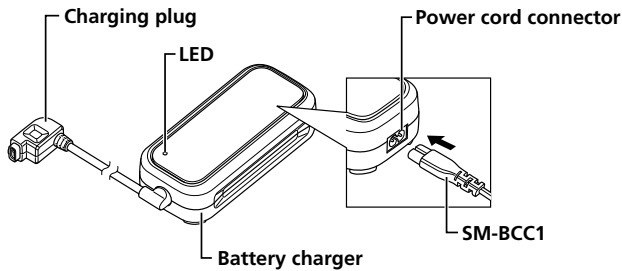

SM-BCC1 (sold separately)

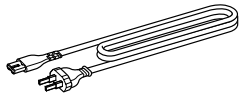

EC-E8004

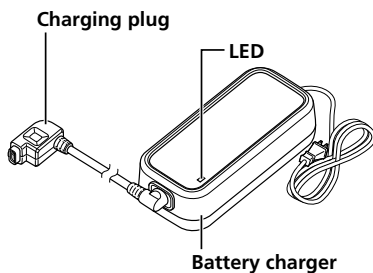

Adapter (sold separately)

SM-BTE60



SM-BTE80



Names of satellite charging port parts

Satellite charging port is installed to the frame. The installation position differs depending on the bicycle.

EW-CP100

Names of parts

Names of satellite charging port parts

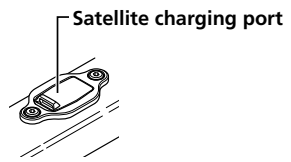

Main specifications

Battery specifications

Some battery models cannot be used in certain regions.

Battery main body	Li-Ion
Nominal capacity	BT-EN404 / BT-EN604: 11.6 Ah BT-EN405 / BT-EN605 / BT-EN805 / BT-EN805-L: 14 Ah BT-EN606 / BT-EN806: 17.5 Ah
Operating temperature range	During discharge: -10 - 50°C During charging: 0 - 40°C
Storage temperature range	-20 - 60°C
Nominal voltage	36 V

- These batteries can only be used for a battery mount with the "Gen.2" mark and a drive unit compatible with a Gen.2 battery management system. For details on compatibility, refer to the compatibility information on the SHIMANO product website (<https://productinfo.shimano.com/#/com>).
- The drive unit may not operate correctly if the latest firmware version is not installed. Connect to E-TUBE PROJECT, then update the firmware.

Battery charger specifications

Input	EC-E6002: 100 - 240 V AC, 1.5 A, 50 / 60 Hz EC-E8004 (United States / Canada): 120 V AC, 1.6 A, 60 Hz EC-E8004 (other regions): 100 - 240 V AC, 1.9 - 0.9 A, 50 / 60 Hz
Output	EC-E6002: 42 V DC, 1.8 A EC-E8004 (United States / Canada): 42 V DC, 4 A EC-E8004 (other regions): 42 V DC, 4 - 4.6 A (input: 100 - 240 V AC)

Charging the battery

Designated charging time

Battery	Charging time from a battery level of 0%		
	EC-E6002	EC-E8004	
		100 - 127 V AC	220 - 240 V AC
BT-EN404, BT-EN604	Approximately 6 hours and 30 minutes	Approximately 3 hours and 30 minutes	Approximately 3 hours
BT-EN405, BT-EN605, BT-EN805, BT-EN805-L	Approximately 7 hours and 30 minutes	Approximately 4 hours and 30 minutes	Approximately 4 hours
BT-EN606, BT-EN806	Approximately 10 hours and 12 minutes	Approximately 5 hours and 40 minutes	Approximately 4 hours and 48 minutes

Charging the battery removed from the bicycle

Charge the battery placed on a level surface.

Orient the battery and the battery charger as indicated in the figure.

* The orientation of the battery charging port differs according to the model.

Rear carrier mount type/built-in type

- 1. Attach the adapter to the battery charger's charging plug.**
- 2. Connect the battery charger's power plug to the electrical outlet.**

Charging the battery

Charging the battery removed from the bicycle

3. Insert the adapter into the battery's charging port.

BT-EN404/BT-EN405

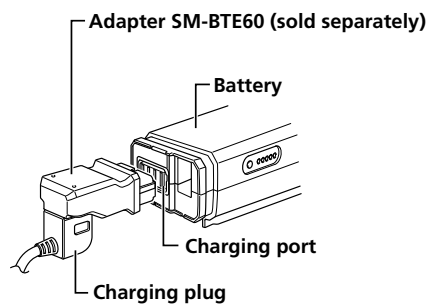
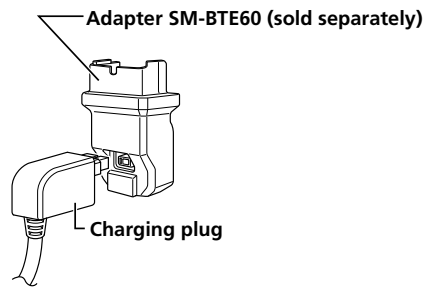

BT-EN805/BT-EN805-L/BT-EN806

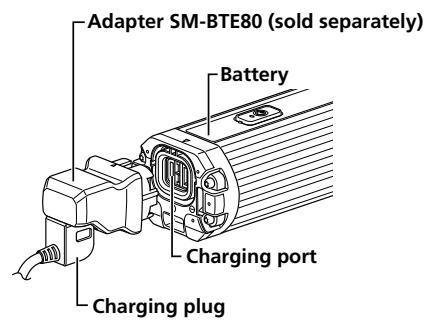
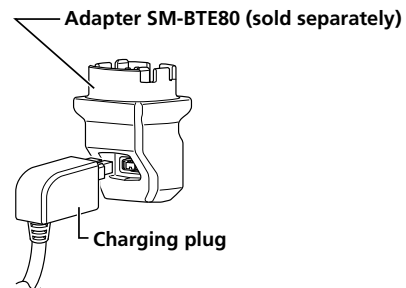

Charging the battery

Charging the battery attached to the bicycle

External type

1. Connect the battery charger's power plug to the electrical outlet.
2. Insert the charging plug into the battery's charging port.

BT-EN604/BT-EN605/BT-EN606

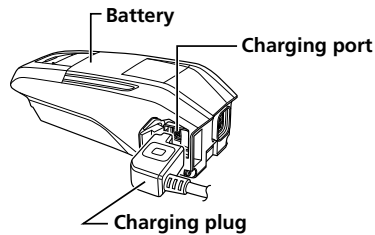

Charging the battery attached to the bicycle

Charge the battery with the battery charger placed on the floor or some other stable surface. Fix the bicycle in place when charging, so that it does not tip over.

1. Connect the battery charger's power plug to the electrical outlet.

Charging the battery

Charging the battery attached to the bicycle

2. Insert the charging plug into the charging port.

BT-EN404/BT-EN405

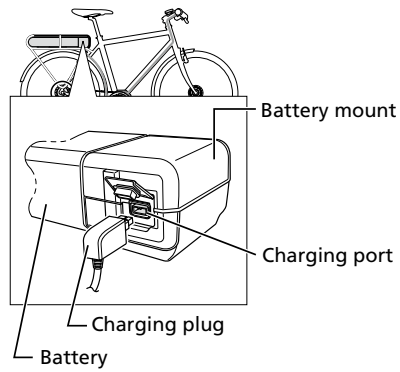

BT-EN604/BT-EN605/BT-EN606

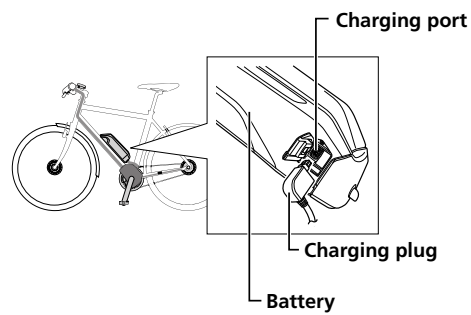

BT-EN805/BT-EN805-L/BT-EN806

The position of the satellite charging port differs depending on the bicycle.

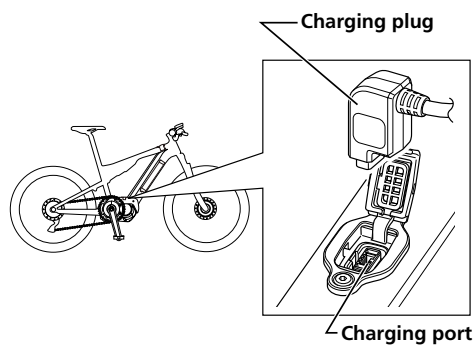

Charging the battery

Battery charger LED

3. After charging, firmly close the charging port cap.

BM-EN400

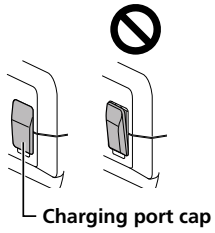

EW-CP100

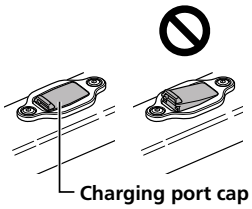

Battery charger LED

After charging has started, the LED on the battery charger lights up. The shape of the LED differs depending on the model.

EC-E6002

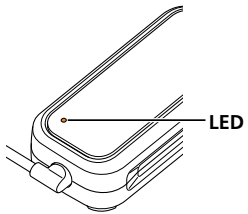

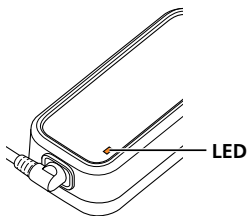

EC-E8004



Charging the battery

Battery LED

 Lit up	Charging
 Flashing	Charge error
 OFF	<ul style="list-style-type: none">• Battery not connected• 1 hour or more after finishing charging• 1 hour or more after an error occurs

NOTICE

The LED does not turn off immediately after charging is complete. Check the charging status using the LED on the battery.





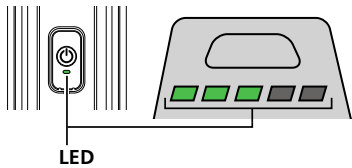

Battery LED

The LED on the battery enables the current charging status and battery level to be checked. The shape of the LED differs depending on the model.



Display while charging

When there are five battery LEDs







Lighting pattern *1	Charging status
	0 - 20%
	21 - 40%
	41 - 60%
	61 - 80%
	81 - 99%
	100%

*1  : Off  : Lit  : Flashing

When there is one battery LED

Charging the battery

Battery LED

Lighting pattern * ₁	Charging status
 (Repeatedly flashes green 1 time)	0 - 20%
 (Repeatedly flashes green 2 times)	21 - 40%
 (Repeatedly flashes green 3 times)	41 - 60%
 (Repeatedly flashes green 4 times)	61 - 80%
 (Repeatedly flashes green 5 times)	81 - 99%
	100% * ₂







*₁  : Off  : Lit  : Flashing

*₂ Turns off one hour after fully charged.

Battery level indicator

You can press the power button to check the current battery level.

When there are five battery LEDs

Lighting pattern * ₁	Battery level
	100 - 81%
	80 - 61%
	60 - 41%
	40 - 21%
	20 - 1%
	0% * If the battery is not attached to the bicycle
	0% * If the battery is attached to the bicycle * If the power is OFF







*₁  : Off  : Lit  : Flashing

When there is one battery LED

- The LED lights up when the battery is attached to the bicycle. (Unless the battery level is at 0%)

Charging the battery

Battery LED

Lighting pattern * 1	Battery level
 (Repeatedly flashes green 5 times)	100 - 81%
 (Repeatedly flashes green 4 times)	80 - 61%
 (Repeatedly flashes green 3 times)	60 - 41%
 (Repeatedly flashes green 2 times)	40 - 21%
 (Repeatedly flashes green 1 time)	20 - 0%
	0% * If the battery is attached to the bicycle

* 1  : Off  : Flashing

TECH TIPS

When the battery level is low, system functions will be shut off in the following order:

- (1) Power assist/free shifting
- (2) Electronic/automatic gear shifting, Anti-lock Braking System (ABS), light

Refer to the "SHIMANO STEPS User's Manual" for details on free shifting and automatic gear shifting.

Proper use of the battery

Charging can be carried out at any time, regardless of the remaining battery, but please fully charge the battery in the following case. Be sure to use the dedicated battery charger.

- The battery cannot be used at the time of purchase. Before riding, be sure to fully charge the battery.

When the battery is completely depleted, charge it as soon as possible. If you leave the battery without charging it, it will cause the battery to deteriorate.

- If the bicycle will not be ridden for a long period, store with the battery level around 70%. Also, make sure to charge the battery every six months to ensure that it does not completely discharge.

Installing the battery

Installing the battery

Secure the battery to the battery mount with a key. There are several types of keys, so there may be differences with this explanation.

- The battery can be inserted without turning the key.
- For details on the compatibility of the battery and battery mount, check the compatibility information on the SHIMANO product website (<https://productinfo.shimano.com/#/com>).

CAUTION

- Firmly hold the battery during installation, being careful not to drop it. Failure to do so may cause the components to fall and break or cause injury.
- Keep the following in mind to prevent the battery from dropping while riding:
 - Confirm that the battery is securely locked to the battery mount.
 - Do not ride with the key inserted.

NOTICE

- Check that the charging port cap is closed before riding the bicycle.
- Before connecting the battery, make sure that the area where the battery will be connected (terminal) is dry and not dirty.

Rear carrier mount type

1. **Insert the battery into the rail from the rear of the bicycle.**
 - Push the battery in firmly to the front.

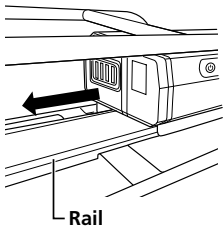

External type

1. **Insert the battery from below.**
 - Align the concave section on the bottom of the battery with the protrusion part on the battery mount, then insert the battery.

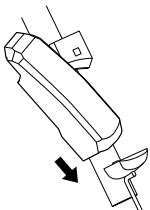

Installing the battery

Installing the battery

2. Push the battery in the direction of the arrow until you feel a click.



Built-in type

The following procedure uses a type of bicycle where the battery is installed/removed from the lower side of the down tube as an example.

1. Use the following procedure to insert from the lower side of the battery:

- (1) Insert from the lower side of the battery.
- (2) Push the battery in the direction of the arrow until you feel a click.

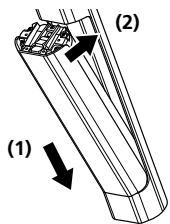

NOTICE

- After pushing the battery in, pull the battery to confirm that it is locked securely.

Removing the battery

Removing the battery

⚠ CAUTION

- Firmly hold the battery during removal or transport, being careful not to drop it. Failure to do so may cause the components to fall and break or cause injury.

Rear carrier mount type

1. Insert the key to release the lock.

- (1) Press the power button to turn the power OFF, then insert the key into the key cylinder on the battery mount.
- (2) Turn the key until you feel it make contact.

Power button

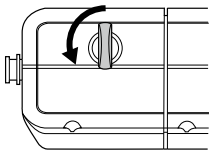
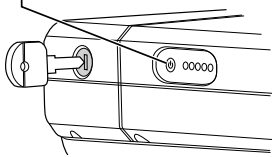

2. Remove the battery.

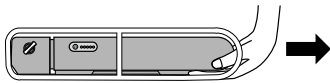

External type

1. Insert the key.

Press the power button to turn the power OFF, then insert the key into the key cylinder on the battery mount.

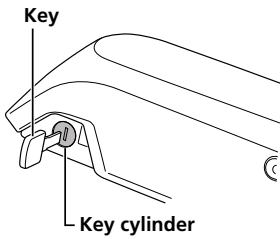
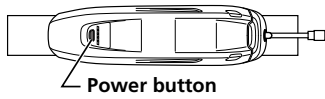

2. Release the battery lock.

Turn the key until you feel it make contact.

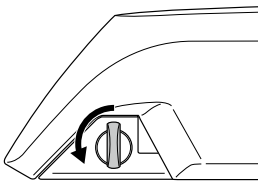

3. Remove the battery.

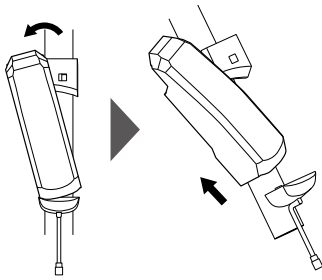

Built-in type

If a battery cover from another company is installed, remove the battery cover first. The following procedure uses a type of bicycle where the battery is installed/removed from the lower side of the down tube as an example.

1. Turn the power OFF.

If there is a keyhole cap, open it.

* The position and operation of the power button differ depending on the bicycle.

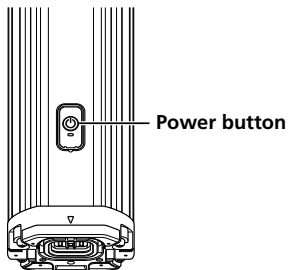

2. Release the battery lock.

- (1) Insert the key into the key cylinder of the battery mount.
- (2) Support the battery with your hand, and turn the key clockwise.

The battery is unlocked. The double latch plate retains the battery in the designated position and prevents it from falling out.

If the battery does not go down into the designated position, pull out the battery with your hand while turning the key.

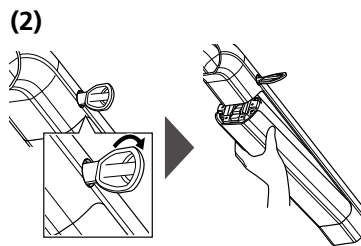
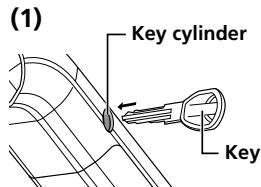

NOTICE

- If the battery is retained with a double latch plate, the double latch plate could deform if struck by a strong external force, causing the battery to drop.
- A hexagon wrench may be used instead of a key, depending on the model. Unlock by turning it 90° clockwise, as shown in the figure. Do not forcibly turn it counterclockwise, or turn it more than 90° clockwise. Doing so may damage it.

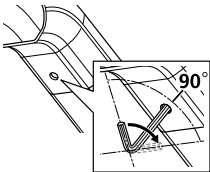

3. Remove the battery.

Remove the battery while supporting it with your hand and pushing the double latch plate.

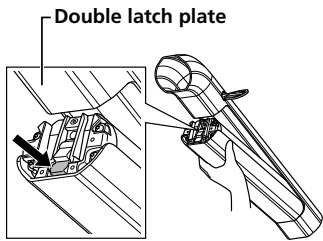

Power ON/OFF

Power ON/OFF

The method for operating the battery power button is described here.

- The power cannot be turned ON while charging.
- When the bicycle has been stopped for 10 minutes, the auto power OFF function automatically switches the power OFF.

NOTICE

- Check the following prior to turning the power ON:
 - The battery is firmly attached to the battery mount.
 - The cycle computer is firmly attached to the bracket (refer to the "SHIMANO STEPS cycle computer user's manual").
- Do not step on the pedal when turning the power ON/OFF. Doing so may cause a system error.

Power ON/OFF

Power ON/OFF

1. Press the battery power button.

The LED lights up and the battery level is displayed.

BT-EN404/BT-EN405

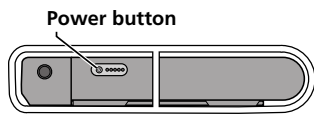

BT-EN604/BT-EN605/BT-EN606

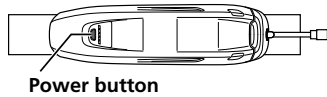

BT-EN805/BT-EN805-L/BT-EN806

- The position of the power button differs depending on the bicycle.

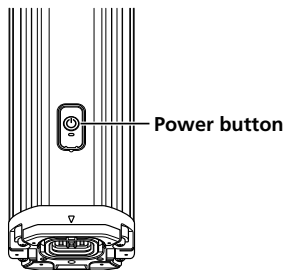

TECH TIPS

Pressing the battery power button for approximately six seconds will force the power OFF for emergencies. (Excluding the BT-EN404/BT-EN405)

Troubleshooting

When a problem occurs





The FAQ for SHIMANO STEPS can be accessed with the following:



Battery LED error indications





System errors and equivalent warnings are displayed with battery LED light-up patterns.

When there are five battery LEDs

Lighting pattern * 1	Indication conditions	Recovery
	Battery overcurrent protection occurred.	If it occurs during charging, remove and reconnect the charging plug. If the situation does not improve, have the place of purchase perform the following: <ul style="list-style-type: none"> • Connect a genuine SHIMANO battery. Also check the power cord for abnormalities. If the error persists, contact your distributor.
	If the temperature exceeds the guaranteed operating range, the battery output stops.	If the temperature is higher than the temperature at which discharging is possible, leave the battery in a cool location with no direct sunlight until the internal temperature of the battery has decreased sufficiently. If it is below the temperature in which discharge is possible, leave the battery indoors, etc. until its internal temperature is suitable.
	Battery does not recognize the drive unit.	If it occurs during charging, remove and reconnect the charging plug. If the situation does not improve, have the place of purchase perform the following: <ul style="list-style-type: none"> • Connect a genuine SHIMANO battery. Also check the power cord for abnormalities. If the error persists, contact your distributor.
	This is displayed if an error occurs during charging.	Remove the battery charger from the battery and press the power button. If an error is displayed, contact the place of purchase.
	Electrical abnormality in battery detected.	Remove the battery charger after connecting it to the battery. Make sure to press the power button with the battery connected. If an error is displayed for the battery alone, have the place of purchase perform the following: <ul style="list-style-type: none"> • Connect a genuine SHIMANO battery. Also check the power cord for abnormalities. If the error persists, contact your distributor.

* 1  : Off  : Lit  : Flashing

When there is one battery LED

Lighting pattern * 1	Indication conditions	Recovery	Error code * 2
 (Repeatedly flashes 5 times)	Electrical abnormality in battery detected.	Remove the battery charger after connecting it to the battery. Make sure to press the power button with the battery connected. If an error is displayed for the battery alone or E023 is displayed on the cycle computer, have the place of purchase perform the following: <ul style="list-style-type: none"> Connect a genuine SHIMANO battery. Also check the power cord for abnormalities. If the error persists, contact your distributor. 	E023
 (Repeatedly flashes 4 times)	Battery overcurrent protection occurred.	Have your place of purchase perform the following: <ul style="list-style-type: none"> Connect a genuine SHIMANO battery. Also check the power cord for abnormalities. If the error persists, contact your distributor. 	E024
	This is displayed if an error occurs during charging.	Remove the battery charger from the battery and press the power button. If an error is displayed, contact the place of purchase.	No display
 (Repeatedly flashes 3 times)	If the temperature exceeds the guaranteed operating range, the battery output stops.	If the temperature is higher than the temperature at which discharging is possible, leave the battery in a cool location with no direct sunlight until the internal temperature of the battery has decreased sufficiently. If it is below the temperature in which discharge is possible, leave the battery indoors, etc. until its internal temperature is suitable.	W200
 (Repeatedly flashes 1 time)	Battery does not recognize the drive unit.	Have your place of purchase perform the following: <ul style="list-style-type: none"> Connect a genuine SHIMANO battery. Also check the power cord for abnormalities. If the error persists, contact your distributor. 	E025

* 1  : Blinking

* 2 Displayed on the cycle computer.

For details on error codes, check the latest versions below:



<https://si.shimano.com/error>

SHIMANO



SHIMANO NORTH AMERICA BICYCLE, INC.
One Holland, Irvine, California 92618, U.S.A. Phone: +1-949-951-5003

SHIMANO EUROPE B.V.
High Tech Campus 92, 5656 AG Eindhoven, The Netherlands Phone: +31-402-612222

MADISON (A DIVISION OF H.YOUNG (OPERATIONS) LTD)
Roebuck Way, Knowlhill, Milton Keynes, Buckinghamshire, MK5 8HL, United Kingdom

SHIMANO INC.
3-77 Oimatsu-cho, Sakai-ku, Sakai City, Osaka 590-8577, Japan

Please note: specifications are subject to change for improvement without notice. (English)
© Mar. 2023 by SHIMANO INC. ITP