

# SHIMANO STEPS

*SHIMANO Total Electric Power System*

---

**Switch Unit Integrated Type**

**Cycle Computer**

**User's Manual**

# CONTENTS

<b>IMPORTANT NOTICE</b> .....	<b>2</b>
<b>Important safety information</b> .....	<b>2</b>
<b>NOTICE</b> .....	<b>2</b>
<b>Regular inspections before riding the bicycle</b> .....	<b>3</b>
<b>Booklet Structure</b> .....	<b>4</b>
<b>Names of parts</b> .....	<b>5</b>
Notation method for operations .....	6
<b>Installing and removing the cycle computer</b> .....	<b>6</b>
<b>Basic operation</b> .....	<b>7</b>
Turning the power ON/OFF .....	7
Viewing the screen .....	8
Battery level indicator .....	9
Turning the light ON/OFF .....	10
Switching the traveling data display .....	11
Display units .....	11
Resetting the traveling distance .....	12
Gear position when starting from a stop [Start mode] .....	12
Making walking and pushing the bicycle easy (walk assist) .....	13
<b>External connections</b> .....	<b>15</b>
E-TUBE PROJECT .....	15
Items configurable in E-TUBE PROJECT .....	15
<b>Troubleshooting</b> .....	<b>15</b>
Gear shifting adjustment with the electronic gear shifting unit [ADJUST] .....	15
Error/warning indication .....	16
Error indication .....	16
Warning indication .....	16
When a problem occurs .....	17

## IMPORTANT NOTICE

- Contact the place of purchase or a distributor for information on installation, adjustment, and replacement of the products which are not found in the user's manual. The dealer's manual for professional bicycle mechanics is available from our website (<https://si.shimano.com>).
- Please observe the appropriate rules and regulations of the country, state or region in which you conduct your business as a dealer.

**For safety, be sure to read this "user's manual" thoroughly before use, follow it for correct use, and store it so that it can be referenced at any time.**

The following instructions must be observed at all times in order to prevent personal injury and physical damage to equipment and surroundings. The instructions are classified according to the degree of danger or damage which may occur if the product is used incorrectly.

### DANGER

Failure to follow the instructions will result in death or serious injury.

### WARNING

Failure to follow the instructions could result in death or serious injury.

### CAUTION

Failure to follow the instructions could cause personal injury or physical damage to equipment and surroundings.

## Important safety information

**This product contains non-replaceable battery.**

## WARNING

- **INGESTION HAZARD:** This product contains a button cell or coin battery.
- **DEATH** or serious injury can occur if ingested.
- A swallowed button cell or coin battery can cause **Internal Chemical Burns** in as little as **2 hours**.
- **KEEP** new and used batteries **OUT OF REACH OF CHILDREN**
- **Seek immediate medical attention** if a battery is suspected to be swallowed or inserted inside any part of the body.



- Remove and immediately recycle or dispose of used batteries according to local regulations and keep away from children. Do NOT dispose of batteries in household trash or incinerate.
- Even used batteries may cause severe injury or death.
- Call a local poison control center for treatment information.
- The compatible battery type:MS920T FL27E
- The nominal battery voltage:3 V
- Non-rechargeable batteries are not to be recharged.
- Do not force discharge, recharge, disassemble, heat above 85°C or incinerate. Doing so may result in injury due to venting, leakage or explosion resulting in chemical burns.

### WARNING

- Do not disassemble or modify the product. This may cause the product to not operate correctly, and you may suddenly fall and be seriously injured.

### Riding precautions

- Do not pay excessive attention to the cycle computer display while riding. Doing so may result in an accident.
- Confirm that the light works before riding.

## Safety precautions

- Be sure to remove the battery and charging cable before wiring or attaching parts to the bicycle. Failure to do so may cause an electric shock.
- Be sure to follow the instructions provided in the manuals when installing the product. It is recommended to use SHIMANO genuine parts only. If bolts and nuts become loose or the product is damaged, the bicycle may suddenly fall over, resulting in a serious injury.
- Do not leave this product in an extremely high temperature surrounding environment such as in a closed vehicle on a hot day, or near a heater. That can result in an explosion of the incorporated battery or the leakage of flammable liquid or gas from it.
- Do not subject this product to extremely low air pressure. That can result in an explosion of the incorporated battery or the leakage of flammable liquid or gas from it. Transporting this product by air is not a problem.

## Disposal precautions

- Observe all federal, state and local environmental regulations when disposing of this product, because it incorporates a battery. Disposal of this product into fire or a hot oven, or mechanically crushing or cutting it can result in an explosion of the incorporated battery.



## Riding precautions

- Observe the instructions in the manual for the bicycle in order to ride safely.

## Safety precautions

- Never modify the system. Doing so may cause a system error.
- Use the product under the supervision of someone responsible for safety, and only as instructed. Do not allow anyone (including children) with reduced physical, sensual, or mental capacity, or those without experience or knowledge, to use the product.
- Do not allow children to play near the product.



## Safety precautions

- If any malfunction or trouble occurs, consult the place of purchase nearest you.
- Be sure to attach caps to any unused connectors.

- For installation and adjustment of the product, consult the place of purchase.
- The components are designed to be fully waterproofed to withstand wet weather riding conditions; however, do not deliberately place them into water.
- Do not clean the bicycle with a high-pressure washer. If water gets into any of the components, operating problems or rusting may result.
- Do not turn the bicycle upside down. There is a risk of damage to the cycle computer and switch unit.
- Handle the components carefully, and avoid subjecting them to strong shock.
- Although the bicycle still functions as a normal bicycle even when the battery is removed, the light will not turn on if it is connected to the electric power system. Be aware that using the bicycle under these conditions will be considered non-observance of the road traffic laws in Germany.

## Connection and communication with PC

A PC linkage device can be used to connect a PC to the bicycle (system or components), and E-TUBE PROJECT can be used to carry out tasks such as customizing single components or the whole system and updating firmware.

- PC linkage device: SM-PCE1/SM-PCE02
- E-TUBE PROJECT: PC application
- Firmware: Software inside each component

## Care and maintenance

- Contact the place of purchase for updates of the component software. The most up-to-date information is available on the SHIMANO website.
- Do not use thinner or other solvents to clean any of the components. Such substances may damage the surface.
- For any questions regarding methods of installation and maintenance, please contact your place of purchase.
- Products are not guaranteed against natural wear and deterioration from normal use and aging.
- For maximum performance we highly recommend SHIMANO lubricants and maintenance products.

## Labels

- Some of the important information contained in this user's manual is also indicated on the device label.

## Regular inspections before riding the bicycle

Before riding the bicycle, check the following items. If any problems are found, consult your place of purchase or a distributor.

- Does the drive train perform gear shifting smoothly?
- Are the components fixed securely and free from damage?
- Are the components securely installed to the frame/handlebar/stem, etc.?
- Do any abnormal noises occur while riding?
- Is there sufficient charge remaining in the battery?

## Booklet Structure

**SHIMANO STEPS user's manuals are split among several booklets, as described below.**

Be sure to read these user's manuals thoroughly before use, and follow them for correct use. Store the user's manuals so that they can be referenced at any time.

The latest user's manuals are available on our website (<https://si.shimano.com>).

### • SHIMANO STEPS user's manual

This is the basic user's manual for SHIMANO STEPS. It contains the following content.

- SHIMANO STEPS quick guide
- How to operate assist bicycles that use flat handlebars, such as city, trekking, or MTB type bicycles
- Troubleshooting

### • SHIMANO STEPS user's manual for drop handlebar bicycles (separate booklet)

This booklet describes how to operate assist bicycles that use a drop handlebar and are controlled using a dual control lever. This should be read along with the SHIMANO STEPS user's manual.

### • SHIMANO STEPS special battery and parts user's manual

It contains the following content.

- How to charge and handle the SHIMANO STEPS special battery
- How to attach and remove the SHIMANO STEPS special battery to the bicycle

- How to use the satellite power button and satellite charging port
- How to read the battery LEDs when charging or during an error, and how to handle errors

### • Cycle computer user's manual (this document)

It contains the following content.

- Basic operations of the cycle computer and how to configure settings
- Wireless communication method (supported models only)
- Cycle computer troubleshooting

### • Switch unit user's manual

This is the assist switch and shifting switch user's manual. It describes switch unit operations.



This symbol on your product, literature, or packaging reminds you that this product must be taken to separate collection at the end of its working life. Do not dispose of this product as unsorted municipal waste but instead take it for recycling. By ensuring the product is disposed correctly, you will help to prevent potential negative consequences for the environment and human health. For info on your nearest recycling point, check with your local waste authority.

## Names of parts

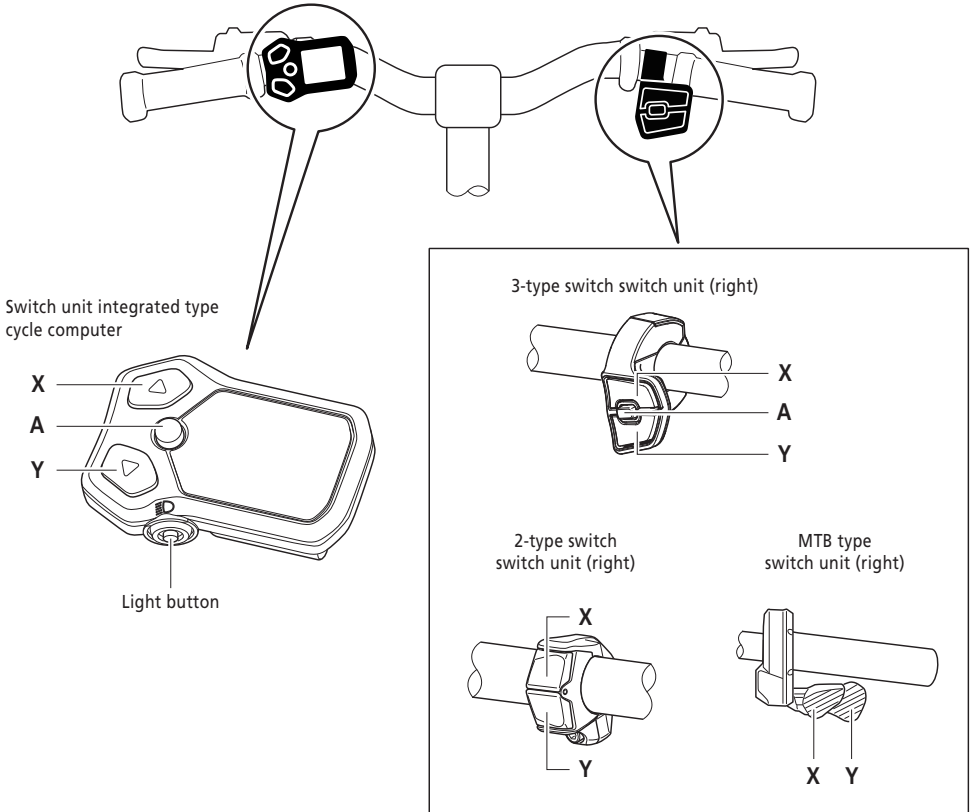

The operation for each button is indicated below.

Switch unit integrated type cycle computer		Switch unit (right)	
<b>Button-X</b>	Increase assistance When in walk assist mode: Disengage walk assist mode *2	<b>Button-X</b>	Shifting up
<b>Button-Y</b>	Decrease assistance Hold down: Switch to walk assist mode *2 When in walk assist mode: Activate walk assist *2	<b>Button-Y</b>	Shifting down
<b>Button-A</b>	Switching traveling data display	<b>Button-A*1</b>	Switch between automatic and manual gear shifting

\*1 Only enabled when the assist bicycle supports automatic gear shifting.

\*2 Depending on the region of use, you may not be able to use it due to the laws of the region. Refer to "Making walking and pushing the bicycle easy (walk assist)" for details on walk assist mode.



- 
- When connected to the E-TUBE PROJECT, you can change the functions assigned to each button on the switch unit. Please contact your place of purchase for details.
  - The button layout may differ according to the switch unit. Refer to the "Switch unit user's manual" for details.
- 

## ■ Notation method for operations

Subsequent operations using the main body button and switch unit of this product are indicated using the following notation.

Notation	Operation
<X>	Indicates an operation for pressing button-X of the cycle computer.
<A>	Indicates an operation for pressing button-A of the cycle computer.
[AUTO] (Example) Auto gear shifting	Items displayed on the cycle computer screen are enclosed in square brackets in this manual.

## Installing and removing the cycle computer

For the installation/removal procedure, contact your place of purchase or the distributor.

## Basic operation

### ■ Turning the power ON/OFF

The power of this product is linked with the main power of the assist bicycle. When the main power is turned ON, all components connected to the drive unit of the assist bicycle are also turned ON (such as assist driving, the power of this product, the electronic gear shifting mechanism, and the lights).

For the procedure for turning the main power ON/OFF, refer to the "SHIMANO STEPS user's manual."

#### NOTICE

- Before turning the power ON, please refer to the "SHIMANO STEPS special battery and parts user's manual" to check the following.
  - The battery is firmly attached to the battery mount
- The power cannot be turned ON while charging.



- If the bicycle is left unused for 10 minutes or more after turning the power ON, the power automatically turns OFF (auto power OFF function).

When the main power is turned ON, a screen similar to that shown below is displayed, and then switches to the main screen.

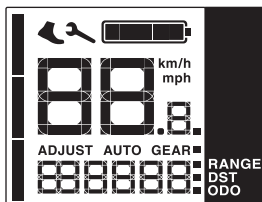



## ■ Viewing the screen

The items displayed on the main screen differ according to the assist bicycle.

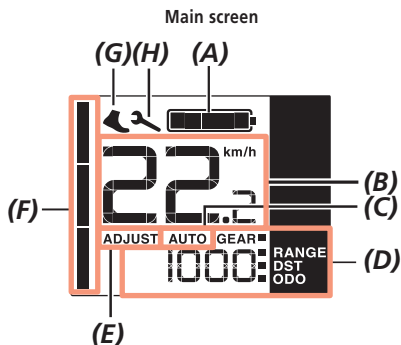

<b>(A)</b>	<b>Battery level indicator</b> (Refer to "Battery level indicator")	<b>(E)</b>	<b>ADJUST mode display</b> (Refer to "NOTICE" below)
<b>(B)</b>	<b>Current speed</b> Displays the current speed. (Refer to "Display units")	<b>(F)</b>	<b>Assist gauge</b> Displays the current assist mode. A mode that provides stronger assistance the longer the length of the displayed gauge.
<b>(C)</b>	<b>Auto gear shifting display</b> Displayed for the auto gear shifting.	<b>(G)</b>	<b>Walk assist*1</b> This icon is displayed when switched to walk assist mode.
<b>(D)</b>	<b>Traveling data display</b> (Refer to "Switching the traveling data display")	<b>(H)</b>	<b>Maintenance alert</b> Indicates that maintenance is required. Contact your place of purchase or a distributor if this icon is displayed.

\*1 Depending on the region of use, you may not be able to use it due to the laws of the region. Refer to "Making walking and pushing the bicycle easy (walk assist)" for details on walk assist mode.

### NOTICE

If you are unable to change gears using the electronic gear shifting, check the cycle computer display for the following.

- If [ADJUST] is displayed on the screen, press <A> on the cycle computer to return to the main screen.
- If the walk assist icon is displayed on the screen, press <X> on the cycle computer to disengage walk assist mode.
- Refer to "Error/warning indication" also.

Example of ADJUST mode screen





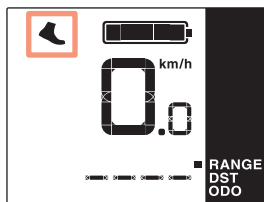



Example of walk assist icon display



## Battery level indicator

The battery level is shown as an icon.

Display	Battery level
	100 - 81%
	80 - 61%
	60 - 41%
	40 - 21%
	20 - 1% *
	0%

\* The battery level indicator will flash when the battery level is low if the assist mode is set to something other than [OFF].



- The cycle computer uses zero to indicate a battery level where assistance cannot be performed. With the SHIMANO STEPS system, the light can still be lit up for a while when assist stops due to a low battery. Therefore, the above-mentioned battery level may differ from that which can be checked on the battery.

## ■ Turning the light ON/OFF

If a light is connected to the drive unit, this product can be used to operate the light.

1. Press the light button.

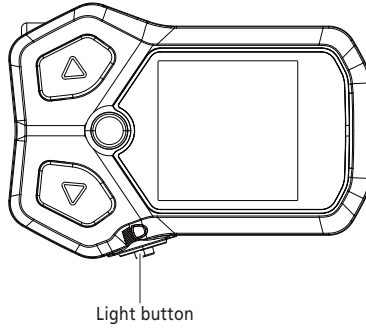

- 
- The light power is linked with the main power. The light cannot be turned ON when the main power is OFF.
-

## ■ Switching the traveling data display

On the main screen, you can check various traveling data in addition to the current speed. The traveling data that can be displayed differs according to the assist bicycle.

1. On the main screen: Press <A>.



The traveling data switches in the following order each time <A> is pressed.

Display item	Explanation
[GEAR]	Current gear position*1
[RANGE]	Traveling range*2
[DST]	Traveling distance
[ODO]	Cumulative distance

\*1 Only displayed for electronic gear shifting.

\*2 The traveling range (reference value) for the selected assist mode. The display switches each time the assist mode is switched. The value is not displayed when the assist mode is set to [OFF].



- If the traveling data display is switched when [ODO] is displayed, the screen will switch back to displaying [GEAR] (for electronic gear shifting) or [RANGE] (for mechanical gear shifting).
- The traveling data display condition that was last displayed is retained even when the power is turned OFF.
- Even when the traveling data display is switched to something other than [GEAR], the screen will switch to displaying [GEAR] for approximately two seconds when a gear shift operation is performed.

## Display units

This product can switch the display units of speed, traveling distance, and cumulative distance to km or miles. It is necessary to connect to E-TUBE PROJECT (PC version) to switch the display units. For the connection method and setting procedure, contact your place of purchase.

### Displayed in km

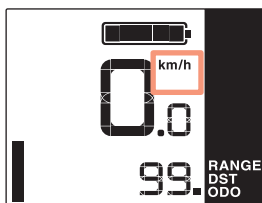

### Displayed in miles

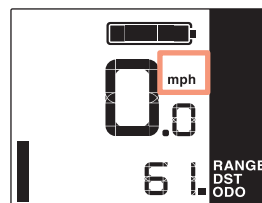

## Resetting the traveling distance

The traveling distance is reset from the main screen.

1. On the main screen: Press <A>. (Switches the traveling data display to [DST])

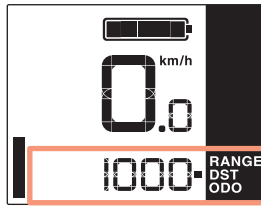

2. Hold down <A>. (Continue to hold down until the number displayed for [DST] flashes)
3. When the number displayed for [DST] is flashing: Press <A>. The traveling data is reset.



- If nothing is done for five seconds after the number for [DST] begins flashing, it will stop flashing and the screen will return to the main screen. The display will automatically return to the main screen when the start of traveling is detected.

### ■ Gear position when starting from a stop [Start mode]

The assist bicycle where this product is installed may be set to automatically switch to a gear where it is easier to start riding again after stopping. If you want to change this setting, contact your place of purchase.

## ■ Making walking and pushing the bicycle easy (walk assist)

Depending on the region of use, you may not be able to use it due to the laws of the region. In this case, the operations described here are disabled.

### 1. Stop and switch to walk assist mode.

Hold down button-Y until it reaches the following state.

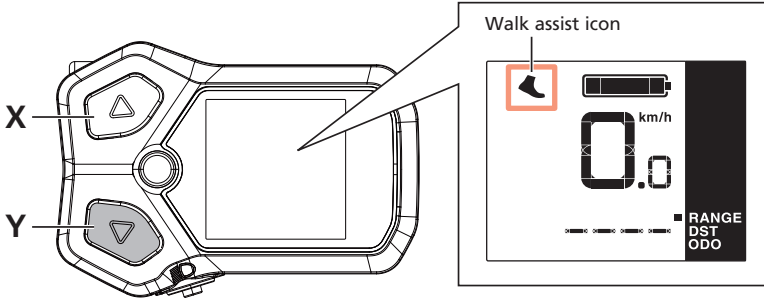

- If nothing is done for one minute after switching to walk assist mode, it will switch back to the assist mode that was selected before switching.

### 2. Push the bicycle carefully while pressing the same button again.

If you let go of button-Y, the assist stops.

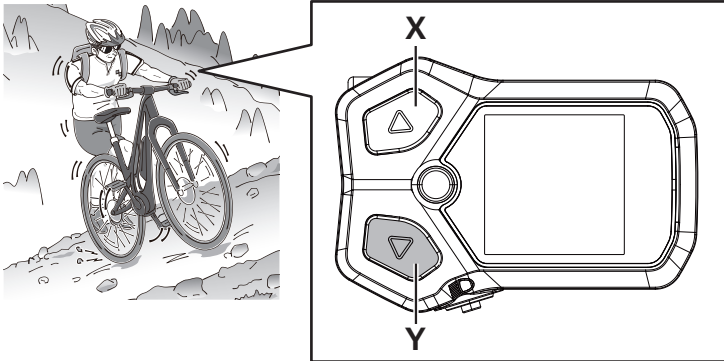

## NOTICE

Walk assist operates at a maximum of 6 km/h. Be careful because the bicycle starts moving just by button operations.



- During electronic gear shifting, the assistance of walk assist and speed are controlled by the current gear position.

### 3. Exit walk assist mode.

Press button-X.

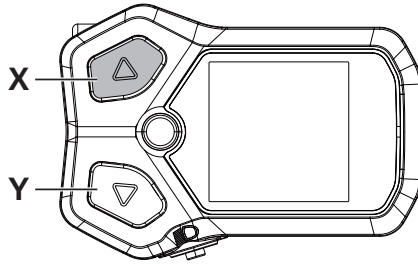

## External connections

This product has a function for communicating with a PC. For the connection method, contact your place of purchase.

### ■ E-TUBE PROJECT

E-TUBE PROJECT is needed to change the setting of the SHIMANO STEPS and to update firmware.

Download E-TUBE PROJECT from our support website (<https://bike.shimano.com/e-tube/project.html>).

For information on how to install E-TUBE PROJECT, check the support website.

#### NOTICE

Do not connect to a device while the battery is being charged.



- Firmware is subject to change without notice.

### Items configurable in E-TUBE PROJECT

The items that can be set differ according to the assist bicycle. Refer to the user's manual for E-TUBE PROJECT for details.

- You can change the functions assigned to each operation switch in [Switch setting].
- You can change the display units for speeds and distances in [Display units].
- You can set/change the gear when starting from a stop in [Start mode]. (Internal electronic gear shifting only)
- You can select to have the backlight of the display always ON, always OFF, or linked to the light in [Backlight setting].

## Troubleshooting

### ■ Gear shifting adjustment with the electronic gear shifting unit [ADJUST]

If gear shifting feels abnormal, contact the place of purchase.



## ■ Error/warning indication

### Error indication

If an error code "E\*\*\*" (where \*\*\* is letters or numbers) is displayed on the entire screen, the product may have malfunctioned.

Refer to the "SHIMANO STEPS special battery and parts user's manual" and follow one of the procedures below to reset the display.

- Press the battery power button to turn the power OFF.
- Remove the battery from the battery mount.



#### NOTICE

- If the situation does not improve even after turning the power back ON, consult with the place of purchase or a distributor as soon as possible.

### Warning indication

If a warning code "W\*\*\*" (where \*\*\* is letters or numbers) is displayed on the screen, the product may have a temporary problem.

If the situation is improved, this indication will disappear. If the situation does not improve, contact the place of purchase as soon as possible.

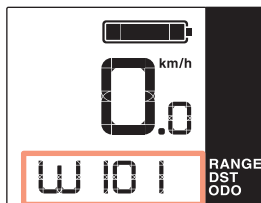

- The PC version of E-TUBE PROJECT (V4 or later) classifies errors and warnings into more detailed categories according to the cause. For this reason, the error and warning codes that are displayed in the PC version of E-TUBE PROJECT may differ from those displayed on this product, E-TUBE RIDE, or smartphone version of E-TUBE PROJECT.

For details on error/warning codes, check the latest versions below:



<https://si.shimano.com/iER/STP0A>

## ■ When a problem occurs

Symptoms	Possible cause	Remedy
The cycle computer screen does not light up when the (main) battery power button is pressed.	The (main) battery level may be too low.	Refer to the "SHIMANO STEPS special battery and parts user's manual" to charge the battery, and then turn the power ON again.
	Is the power ON?	Refer the "SHIMANO STEPS special battery and parts user's manual" to turn the power ON.
	Is the battery charging?	When charging with the battery installed to a bicycle, you cannot turn the power ON. Stop charging.
	Is the connector of the electric wire installed correctly?	Check whether the connector of the electric wire is disconnected. If you are not sure, contact the place of purchase.
	A product that the system cannot identify may be connected.	Contact the place of purchase.
The gear position is not displayed.	The gear position is only displayed when the electronic gear shifting unit is installed.	Check whether the connector of the electric wire is disconnected. If you are not sure, contact the place of purchase.
The gear shifts by itself when the bicycle starts from a stop.	On bicycles with internal electronic gear shifting specifications, the bicycle may be set in advance to automatically switch to a gear where it is easy to start from a stop ([Start mode]).	It is necessary to connect to E-TUBE PROJECT to disable or change the setting of [Start mode]. Contact the place of purchase.
The gear position set in [Start mode] is not set when the bicycle is stopped.	You may have pressed the pedal too strongly.	Pressing the pedal gently makes it easier to shift gears.

# SHIMANO

## **SHIMANO NORTH AMERICA BICYCLE, INC.**

One Holland, Irvine, California 92618, U.S.A. Phone: +1-949-951-5003

## **SHIMANO EUROPE B.V.**

High Tech Campus 92, 5656 AG Eindhoven, The Netherlands Phone: +31-402-612222

## **MADISON (A DIVISION OF H.YOUNG (OPERATIONS) LTD)**

Roebuck Way, Knowlhill, Milton Keynes, Buckinghamshire, MK5 8HL, United Kingdom

## **SHIMANO INC.**

3-77 Oimatsu-cho, Sakai-ku, Sakai City, Osaka 590-8577, Japan

Please note: specifications are subject to change for improvement without notice. (English)

© Mar. 2024 by SHIMANO INC. ITP