

## User's Manual

# Hydraulic Disc Brake (SHIMANO Low Viscosity Oil)



---

## Contents



<b>IMPORTANT NOTICE</b> .....	<b>3</b>
<b>Important safety information</b> .....	<b>4</b>
<b>Notice</b> .....	<b>6</b>
<b>Regular inspections before riding the bicycle</b> .....	<b>7</b>
<b>Names of parts</b> .....	<b>8</b>
<b>How to operate</b> .....	<b>9</b>
<b>How to perform bed-in</b> .....	<b>10</b>

# IMPORTANT NOTICE

- Contact the place of purchase or a distributor for information on installation, adjustment, and replacement of the products which are not found in the user's manual. A dealer's manual for professional and experienced bicycle mechanics is available on our website ( <https://si.shimano.com> ).

**For safety, be sure to read this user's manual thoroughly before use, follow it for correct use, and store it so that it can be referenced at any time.**

The following instructions must be observed at all times in order to prevent personal injury and physical damage to equipment and surroundings. The instructions are classified according to the degree of danger or damage which may occur if the product is used incorrectly.

	<b>DANGER</b>	Failure to follow the instructions will result in death or serious injury.
	<b>WARNING</b>	Failure to follow the instructions could result in death or serious injury.
	<b>CAUTION</b>	Failure to follow the instructions could cause personal injury or physical damage to equipment and surroundings.

# Important safety information

## **⚠ WARNING**

- Because each bicycle may handle slightly differently depending on the model, be sure to learn the proper braking technique (including brake lever pressure and bicycle control characteristics) and operation of your bicycle. Improper use of your bicycle's brake system may result in a loss of control, which could lead to serious injury due to a fall or collision.
- Do not disassemble or modify the product. This may cause the product to not operate correctly, and you may suddenly fall and be seriously injured.
- Riders must become accustomed to the higher performance of this brake before riding the bicycle. The 220 mm, 203 mm, and 180 mm rotors provide a higher braking force than the 160 mm rotors. If you ride the bicycle without becoming sufficiently familiar with the braking characteristics, braking may cause you to fall off the bicycle, potentially causing serious injury or a fatal accident.
- Keep your fingers away from the rotating rotor. The rotor is sharp enough to inflict severe injury to your fingers if caught.



- Do not touch the calipers or rotor while riding or immediately after dismounting from the bicycle. The calipers and rotor will become hot when the brakes are operated, so you may get burned if you touch them.
- Do not allow any oil or grease to get onto the rotor or pads. Riding the bicycle with oil or grease on the rotor or pads may prevent the brakes from operating and result in serious injury due to a fall or collision.
- Check the thickness of the pads and do not use them if they have a thickness of 0.5 mm or less. Doing so may prevent the brakes from operating and result in serious injury due to a fall or collision.

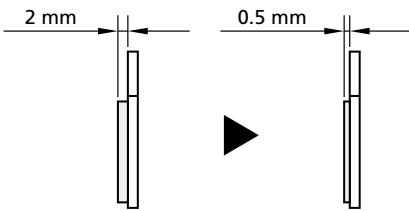

- Do not use the rotor if it is cracked or deformed. The rotor may break and result in serious injury due to a fall.
- Do not use the rotor if its thickness is 1.5 mm or less. Also do not use it if the aluminum surface becomes visible. The rotor may break and result in serious injury due to a fall.
- Do not continuously apply the brakes. Doing so may cause a sudden increase in the brake lever stroke, preventing the brakes from operating and resulting in serious injury due to a fall or collision.

- Check the information on the supported models for each oil type, and use the correct oil for the product. Failure to do so may prevent the brakes from operating and result in serious injury.



<https://si.shimano.com/dm/BROIL>

- Do not mix SHIMANO hydraulic mineral oil with SHIMANO low viscosity oil. Doing so may prevent the brakes from operating and result in serious injury.
- Do not use the brakes with fluid leaking. Doing so may prevent the brakes from operating and result in serious injury due to a fall or collision.
- Do not apply the front brake too strongly. If you do so, the front wheel may lock and the bicycle may fall forward, and serious injury may result.
- Because the required braking distance will be longer during wet weather, reduce your speed and apply the brakes early and gently. Failure to do so may result in serious injury due to a fall or collision.
- A wet road surface may cause tires to lose traction; therefore, to avoid this, reduce your speed and apply the brakes early and gently. If the tires lose traction, you may fall and be seriously injured.

## **⚠ CAUTION**

- Cautions on SHIMANO low viscosity oil
  - If SHIMANO low viscosity oil enters your eyes, flush with fresh water and seek medical assistance immediately. Contact with eyes may result in irritation.
  - If SHIMANO low viscosity oil contacts your skin, wash well with soapy water. Contact with skin may cause a rash and discomfort.
  - When using SHIMANO low viscosity oil, cover your nose and mouth with a respirator type mask and ensure that the area is well-ventilated. Inhalation of oil mist or vapors emitted from SHIMANO low viscosity oil may cause nausea.
  - If oil mist or vapor emitted from SHIMANO low viscosity oil is inhaled, go immediately to an area with fresh air. Cover up with a blanket. Stay warm and stable and seek professional medical advice.
- Bed-in period
  - Disc brakes have a bed-in period, and the braking force will gradually increase as the bed-in period progresses. Accidents or falls may occur due to losing control of the bicycle, possibly resulting in serious injury. (The same thing will happen when the pads or rotor are replaced.)

# Notice

- To prevent noise and ensure the best performance, perform the bed-in procedure after replacing the pads or rotor.
- In the case of carbon levers, wash them with a soft cloth using a neutral detergent. Otherwise, the material may be damaged and lose strength.
- Avoid leaving the carbon levers in places where high temperatures are present. Also keep them well away from fire.
- When the bicycle wheel has been removed, it is recommended that pad spacers are installed. Do not depress the brake lever while the wheel is removed. If the brake lever is depressed without the pad spacers installed, the pistons will protrude further than normal. If that happens, consult a place of purchase.
- Use soapy water and a dry cloth when cleaning and carrying out maintenance of the brake system. Do not use commercially available brake cleaners or silencing agents. Such substances can cause damage to parts such as seals.
- Products are not guaranteed against natural wear and deterioration from normal use and aging.
- For maximum performance we highly recommend SHIMANO lubricants and maintenance products.

# Regular inspections before riding the bicycle

Before riding the bicycle, check the following items. If any problems are found, consult your place of purchase or a distributor.

- Are there any signs of brake oil leakage?
- Do the front and rear brakes work correctly?
- Do the pads have a thickness of 0.5 mm or more?
- Is the rotor cracked or deformed?
- Are the levers securely installed to the handlebar?
- Are there signs of cracks or peeling on the levers?
- Are there any abnormal noises?
- When the lever is depressed, is it hitting the handlebar?

# Names of parts

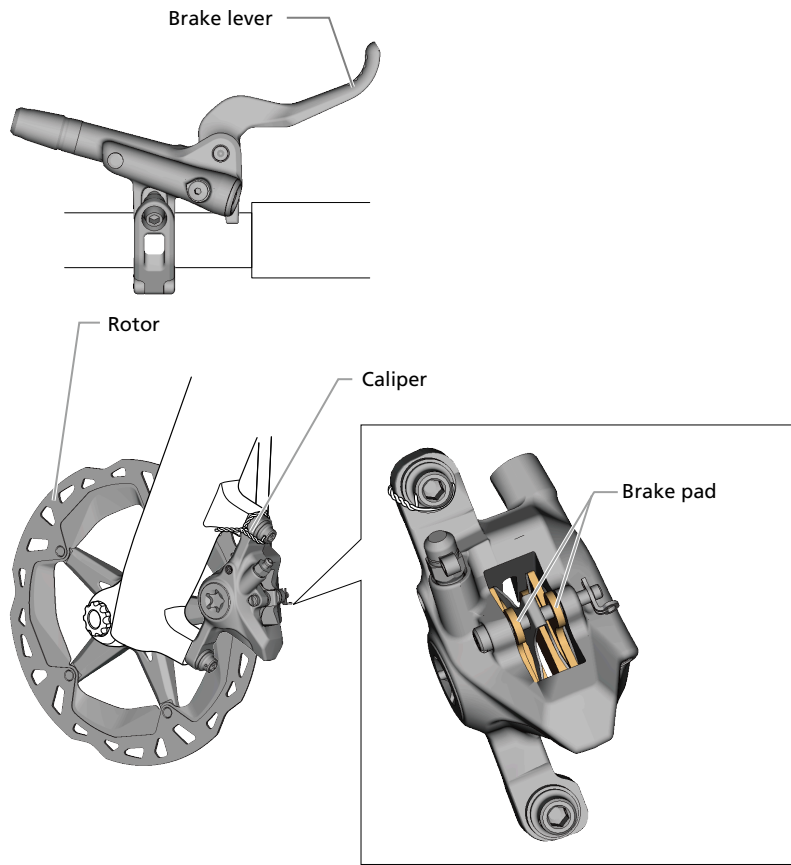

# How to operate

This product has a reach adjustment function.

If the brake levers seem too far away and are difficult to reach, contact the place of purchase or a distributor.

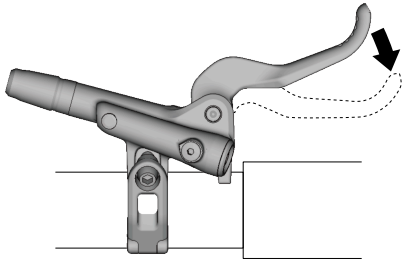

# How to perform bed-in

To optimize the performance of the pads and rotor, perform the bed-in procedure as explained in the steps below:

- 1. Ride your bicycle in a flat and safe area without obstacles and depress the brake lever an amount that enables pedaling.**

Do this only with one brake lever at a time. For your bicycle with gear shifting capability, shifting the chain to the largest sprocket and the smallest chainring makes pedaling easier. If it has the assist function, perform bed-in with the function OFF. Performing bed-in with the function ON may overheat the rotor and cause discoloration and noise.

- 2. With the brake lever depressed, ride your bicycle for 20 m.**
- 3. Repeat steps 1 and 2 at least 10 times for both the front and rear brakes.**

While repeating the process, the braking force will increase.

## CAUTION

- When using resin pads, perform bed-in for a longer period of time than metal pads. Resin pads are designed to reduce the amount of noise generated between the pads and the rotor when the brakes are operated. A longer bed-in period is required than for metal pads.
- Disc brakes have a bed-in period, and the braking force will gradually increase as the bed-in period progresses. You may lose control of the bicycle, which can result in serious injury due to a fall or collision. (The same thing will happen when the pads or rotor are replaced.)

# SHIMANO

**SHIMANO NORTH AMERICA BICYCLE, INC.**  
One Holland, Irvine, California 92618, U.S.A. Phone: +1-949-951-5003

**SHIMANO EUROPE B.V.**  
High Tech Campus 92, 5656 AG Eindhoven, The Netherlands Phone: +31-402-612222  
Only EU General Contact : [contactshimano@shimano-eu.com](mailto:contactshimano@shimano-eu.com)

**SHIMANO INC.**  
3-77 Oimatsu-cho, Sakai-ku, Sakai City, Osaka 590-8577, Japan

Please note: specifications are subject to change for improvement without notice. (English)  
© Jun 2025 by SHIMANO INC. ITP