



INTER 

SERVICE MANUAL

SG-C6061-8R
SG-C6061-8V
SG-C6061-8C
SG-C6061-8D
SG-C6061-8CD

SG-C6011-8R
SG-C6011-8V
SG-C6001-8R
SG-C6001-8V
SG-C6001-8C
SG-C6001-8D
SG-C6001-8CD

CONTENTS

Introduction of INTER-8	2
Dealer's Manual	5
SG-C6061-8R, SG-C6061-8V, SG-C6061-8C, SG-C6061-8D SG-C6061-8CD	
• INSTALLATION	
• ADJUSTMENT	
• MAINTENANCE	
SG-C6011-8R, SG-C6011-8V, SG-C6001-8R, SG-C6001-8V SG-C6001-8C, SG-C6001-8D, SG-C6001-8CD	
• INSTALLATION	
• CONNECTION OF THE ELECTRIC WIRES	
• MAINTENANCE	
Troubleshooting	65
Disassembly & Assembly	69
Required Tools & Parts	
Replacing the Internal Assembly	
Disassembling the Internal Assembly	
Assembling the Internal Assembly	
Service Parts & Tools	90
Cassette Joint	
Measurement Tool	
Motor unit	
NEXUS non-turn washers	
Interchangeability between hubs	94
Hub dimensions (Over Locknut Dimensions and Axle)	96
EV / Spare Parts List	101



The new standard in internal geared hubs

BIKE DESIGN

The NEXUS 8-speed system delivers a new level of design, quality and function. Our designers have updated the conventional internal hub with a refreshing new design inspired by the concepts of beauty, innovation and integrity. Many technical advances have been achieved, like incorporating Shimano's unique gear change support mechanism that makes a real low effort shifting.



SG-C6011-8R



SG-C6061-8V

SG-C6011-8R

SG-C6001-8R

SG-C6061-8R

SG-C6011-8V

SG-C6001-8V

SG-C6061-8V

SG-C6001-8C

SG-C6061-8C

SG-C6001-8D

SG-C6061-8D

SM-C6001-8CD

SM-C6061-8CD

TECHNOLOGIES

INTER-8

The INTER-8 hub has increased its gear ratio to 307%, compared to 244% of the INTER-7 hub. The INTER-8 hub also incorporates a closer gear ratio allowing a more efficient and comfortable pedaling cadence. A truly "all conditions" internal hub has arrived.

Equipped: SHIMANO ALFINE/SHIMANO NEXUS INTER-8

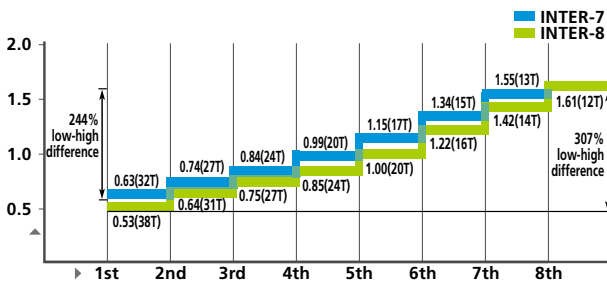

The table above shows the relative gear ratio for the INTER-7 and INTER-8 gear hubs when used with a 20T sprocket. The numbers in parenthesis show the sprocket size that each gear ratio corresponds to in a derailleur system.

Gear Change Support

SHIMANO gear change support mechanism utilizes some portion of pedaling force at down shifting. The result is a quick and precise downshift with very light feeling. For the automatic shifting system, this gear change support mechanism is the key. Shifting effort is reduced to the point where the hub can be shifted through a small low-torque DC motor. Less electricity is required, so a smaller battery allows the system to be lighter and more compact.

Equipped: SHIMANO ALFINE/SHIMANO NEXUS INTER-8/SHIMANO NEXUS INTER-3

40% less shifting force required

Pedaling force is applied against the sleeve to help overcome sleeve return pressure and execute the shift.

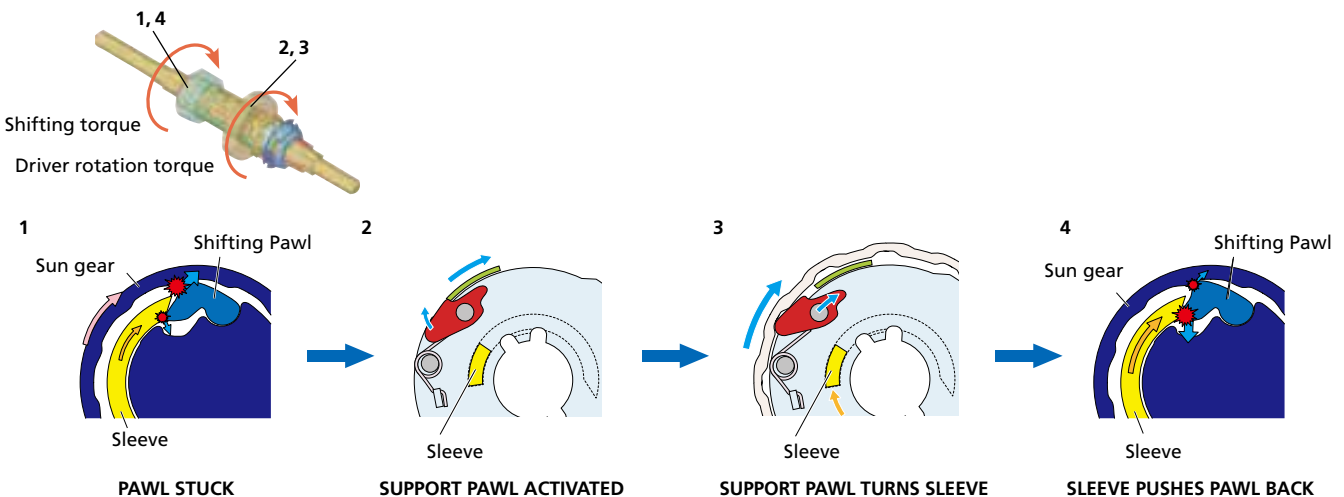

Labyrinth & Contact Sealing

Specifically designed seals inside the hub shut out mud, dust, dirt and moisture and protect the bearing mechanisms, realizing low maintenance as well as longer service life.

This maintains the original performance for a longer period of time under unfavorable environmental conditions.



Labyrinth & contact seal (road)

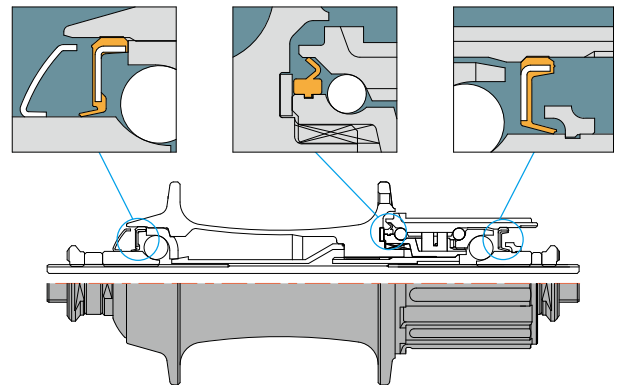

TECHNOLOGIES



CENTER LOCK System

The CENTER LOCK system makes an easy disc brake rotor installation possible with spline mount and a lock ring. The lock ring mounting system reduces the total working hours by shortening the amount of time of both installation and de-installation. In addition, the secure fixing by the spline mount enhances precision and rigidity while improving braking efficiency.

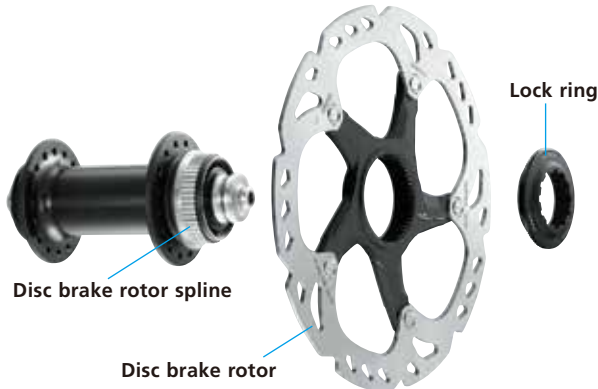

Roller Brake

SHIMANO multi-condition roller brake use a precision cam-and-roller design that delivers strong yet easily controllable braking power. Large disc-type radial cooling fins keep temperatures down, eliminate fade, and extend service life of the lubricant. Sealing channels keep out dirt and water to assure safe and dependable braking performance in wet or dry conditions.

Equipped: SHIMANO NEXUS/SHIMANO TOURNEY

Multi-Purpose Roller Brake

With the adoption of a V-shaped brake shoe and larger cooling fins, the braking force is closer to that of a mechanical disc brake. The V-shaped brake shoes increase braking power while the large fin raises heat dissipation efficiency that allows it to brake longer and harder without fading. These upgrades make the roller brake more suitable for a wider variety of bicycles.

Equipped: BR-C6000/C3010/C3000

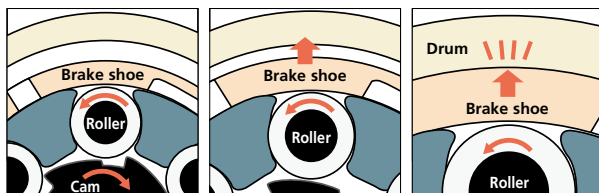

Cam and roller rotate when brake is applied. Brake shoe moves up to drum while roller is rotating. Brake shoe contacts drum to begin braking.

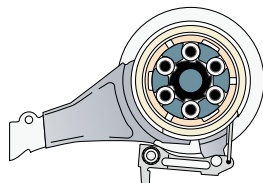

Coaster Brake

The SHIMANO NEXUS coaster brake is operated by pedaling backward in a similar way as ordinary types. Its uniqueness is that braking power transmitted to the wheel directly for the SHIMANO NEXUS internal coaster brake is independent of the gear shifting mechanism built into the hub.

Also it always generates the same braking force regardless of gear position to actualize comfortable and reliable riding. For INTER-7/INTER-3, it actualizes the braking force to meet the ISO 4210 standard.

In particular, the INTER-8C is 60% more powerful than the INTER-7C.

Equipped: SHIMANO NEXUS INTER-8/SHIMANO NEXUS INTER-7/SHIMANO NEXUS INTER-3



CEN standard approved by SMP (Svensk Maskinprovning AB)

Powerful braking force regardless of gear position

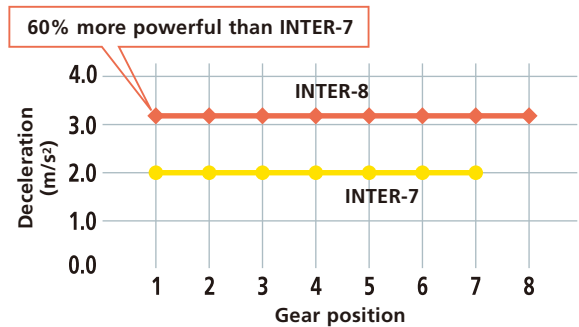

Equal braking force in each gear

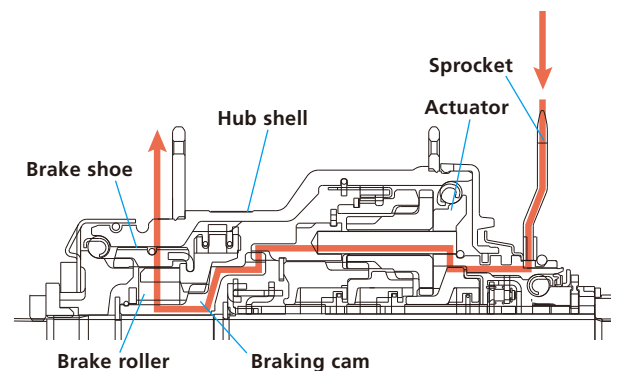



Dealer's Manual

SG-C6061-8R
SG-C6061-8V
SG-C6061-8C
SG-C6061-8D
SG-C6061-8CD

INSTALLATION

Installation of the sprocket to the hub

Place the right-hand dust cap B/right-hand dust cap C onto the driver on the right side of the hub body.

Next, install the sprocket and secure it in place with the snap ring.

Specifications	Applicable sprockets	
	Outward assembling	Inward assembling
A	16T-23T	20T-23T
B	16T-23T	

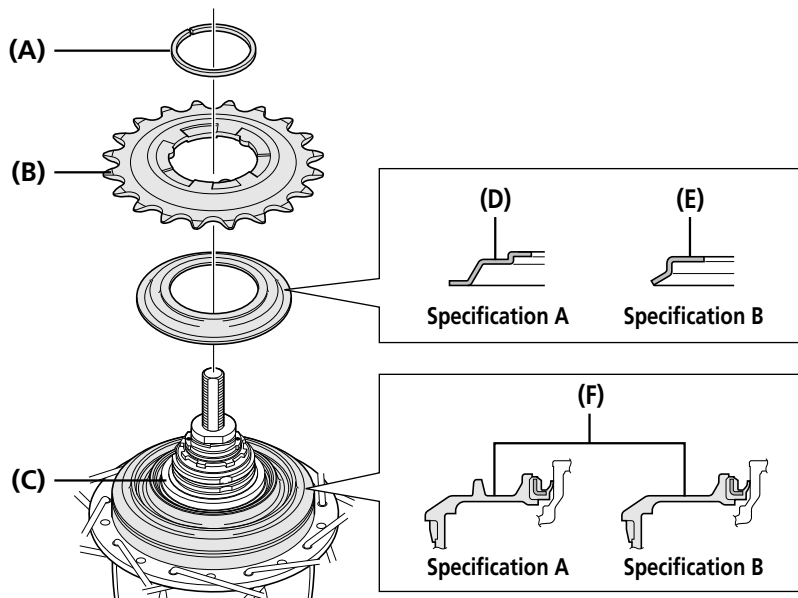

- (A) Snap ring
- (B) Sprocket
- (C) Driver
- (D) Right-hand dust cap A
- (E) Right-hand dust cap B
- (F) Right-hand dust cap A

NOTICE

Note the orientation of the right-hand dust cap.

Specification A

If the sprocket is an inward assembling sprocket with 19T or fewer or for belt drive specifications, right-hand dust cap A will come into contact with the chain or pulley so specification B should be used instead.

Specification B

If the sprocket is an inward assembling sprocket with 16T and 3mm teeth or for belt drive specifications, remove right-hand dust cap B before use.



Installation of the cassette joint to the hub

1

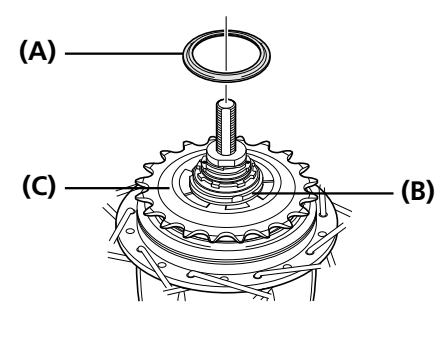

Install the driver cap to the driver on the right side of the hub body.

- (A) Driver cap
- (B) Driver
- (C) Sprocket

NOTICE

Note the orientation of the driver cap.

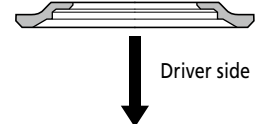

Install the driver cap in the position shown in the illustration.

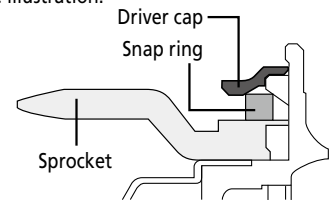

2

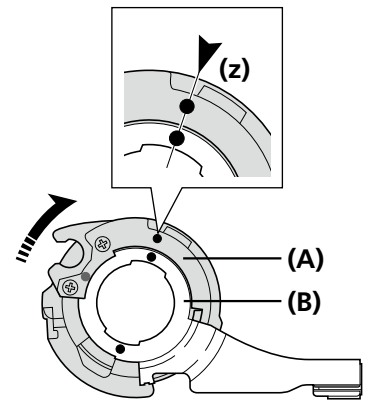

Turn the cassette joint pulley in the direction of the arrow to align the red ● marks on the pulley and the bracket.

(z) Should be aligned

- (A) Pulley
- (B) Bracket

3

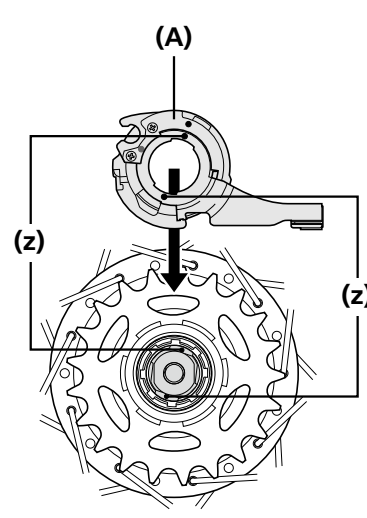

Install it with the red ● marks (z) on the cassette joint aligned with the red ● (SG-C6001/SG-C6011) or yellow ▲ (SG-C3001) marks (z) on the right side of the hub body.

- (A) Cassette joint



Click here for the latest Dealer's Manual

<https://si.shimano.com/DM/CASG001>

4

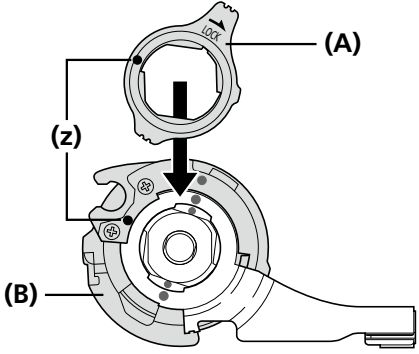

Secure the cassette joint to the hub with the cassette joint mounting ring.

When installing the cassette joint mounting ring, align the yellow ● mark (z) with the yellow ● mark (z) on the pulley of the cassette joint.

- (A) Cassette joint mounting ring
- (B) Pulley

5

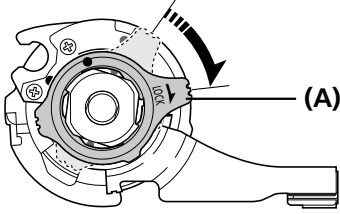

Turn the cassette joint mounting ring 45° clockwise.

- (A) Cassette joint mounting ring

NOTICE

Hold down the cassette joint bracket securely when performing work.



Click here for the latest Dealer's Manual

<https://si.shimano.com/DM/CASG001>

■ Installing the Inter-M brake to the hub body

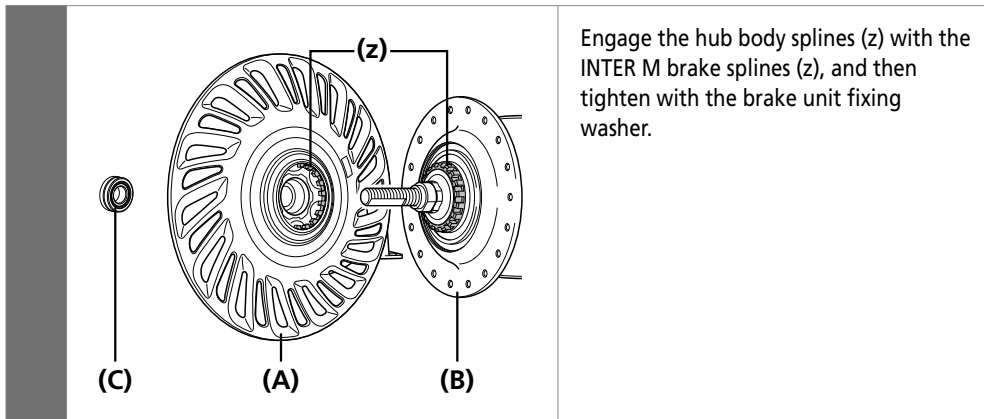

Engage the hub body splines (z) with the INTER M brake splines (z), and then tighten with the brake unit fixing washer.

- (A) Inter-M brake
- (B) Hub body
- (C) Brake unit fixing washer

■ Installation of the hub to the frame

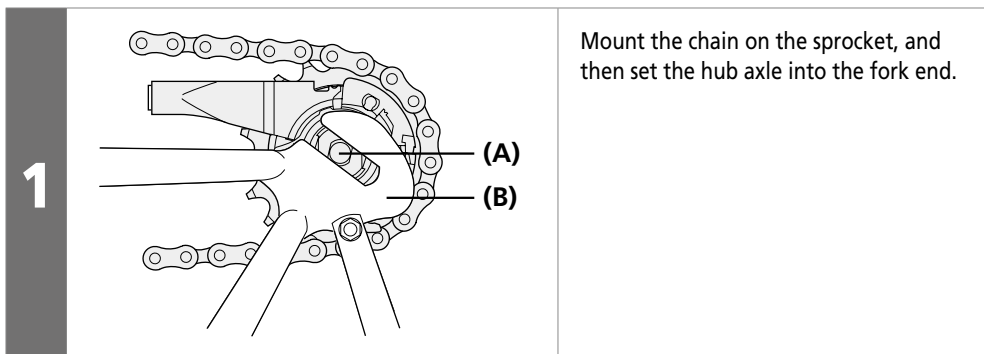

Mount the chain on the sprocket, and then set the hub axle into the fork end.

- (A) Hub axle
- (B) Fork end



Place non-turn washers and onto the right and left sides of the hub axle.

At this time, turn the cassette joint so that the protrusions of the non-turn washers fit into the grooves in the fork ends and align the joint to be almost parallel to the chainstay.

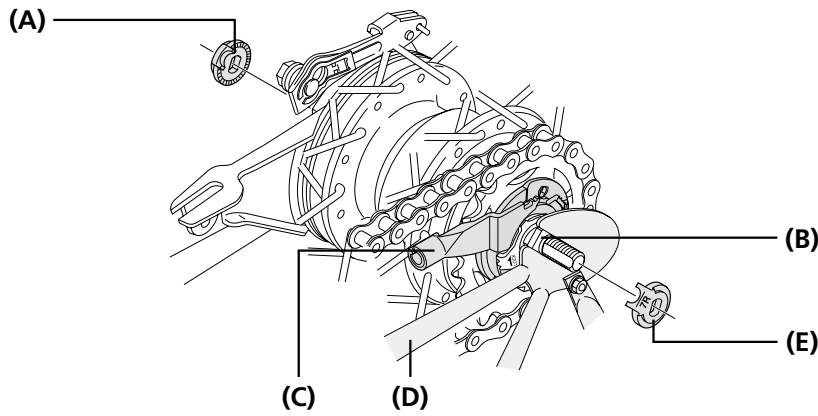

- (A) Non-turn washer (for left-side use)
- (B) Groove in fork end
- (C) Cassette joint
- (D) Chainstay
- (E) Non-turn washer (for right-side use)

NOTICE

When installing parts such as a mudguard stay to the hub axle, install them in the order shown in the illustration below.

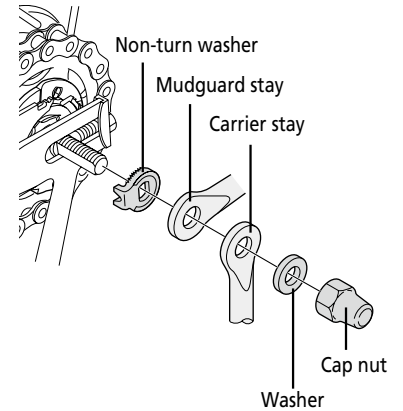

2

TECH TIPS

- The protrusion should be on the fork end side.
- Install the non-turn washer so that the protrusion fits securely in the fork end groove at the front and back sides of the hub axle.
- Use a non-turn washer that matches the shape of the fork end. Different non-turn washers are used for the left and right sides.

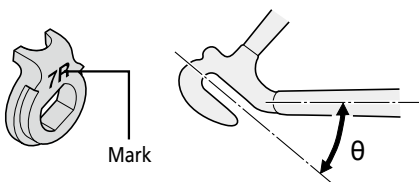

Fork end	Non-turn washer		Size
	Mark/Color		
	For right	For left	
Standard	5R/Yellow	5L/Brown	$\theta \leq 20^\circ$
	7R/Black	7L/Gray	$20^\circ \leq \theta \leq 38^\circ$
Reversed	6R/Silver	6L/White	$\theta = 0^\circ$
Reversed (Full chain case)	5R/Yellow	5L/Brown	$\theta = 0^\circ$
Vertical	8R/Blue	8L/Green	$\theta = 60^\circ - 90^\circ$

Note: Vertical type does not include the coaster specifications



Click here for the latest Dealer's Manual

<https://si.shimano.com/DM/CASG001>

In the case of Inter-M brake specifications

2

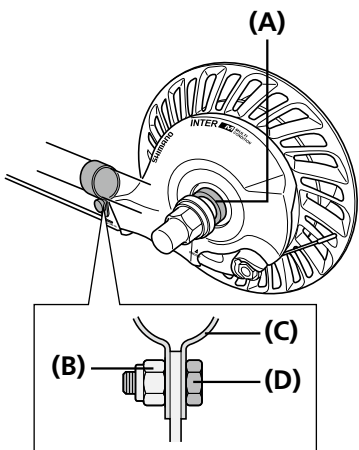

Attach the brake arm of the Inter-M brake to the chainstay with the brake arm clip.

Next, temporarily fix the clip bolt and clip nut by lightly tightening them.

- (A) Brake fixing washer (insert manually)
- (B) Clip nut
- (C) Arm clip
- (D) Clip bolt (M6 x 16mm)

NOTICE

Check that the brake unit is firmly secured to the hub with the brake unit fixing washer.

TECH TIPS

If the hub nuts are cap nuts, use a frame with fork ends that are at least 7mm thick.

3

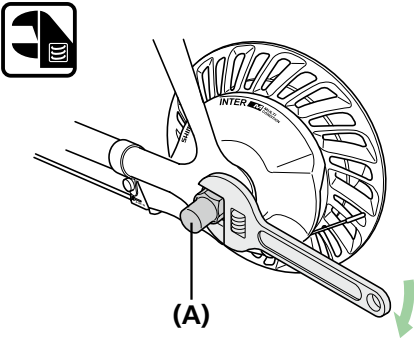

Take up slack in the chain and secure the wheel to the frame with the cap nut.

- (A) Hub nut

Tightening torque	
	30 - 45 N·m

NOTICE

Check that the wheel is fixed securely to the frame with the hub nut.



Click here for the latest Dealer's Manual

<https://si.shimano.com/DM/CASG001>

Fix the brake arm securely to the chainstay with the arm clip.

Check that the brake arm is securely fastened to the chainstay with the brake arm clip.

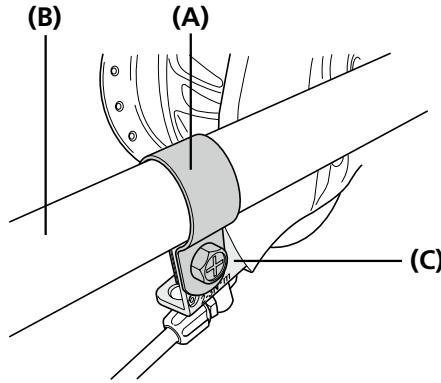

In the case of coaster brake specifications

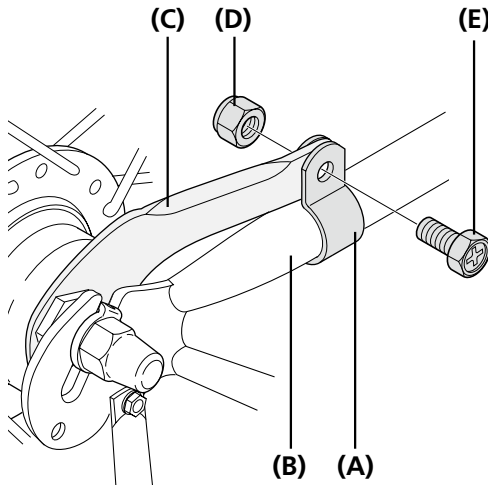

- (A) Arm clip
- (B) Chainstay
- (C) Brake arm
- (D) Clip nut
- (E) Clip bolt (M6 x 16mm)

Tightening torque



2 - 3 N·m

WARNING

- When securing the brake arm to the frame, be sure to use a brake arm clip that matches the size of the chainstay, and securely tighten them with the clip bolt and clip nut to the specified tightening torque.
- Use a lock nut with a nylon insert (self-locking nut) as the clip nut.
- It is recommended that Shimano made clip bolts, clip nuts, and arm clips be used.
- If the clip nut comes off the brake arm, or if the clip bolt or arm clip becomes damaged, the brake arm may rotate on the chainstay and cause the handlebars to jerk suddenly, or the bicycle wheel may lock and the bicycle may fall over, causing serious injury.

NOTICE

- If it is not installed correctly, braking performance will suffer. Be careful not to apply excessive force when installing.
- If excessive force is applied to the brake arm to secure it, the wheel will make noise and become difficult to turn.
- After installing the arm clip, check that the clip bolt protrudes about 2 to 3mm from the end face of the clip nut.

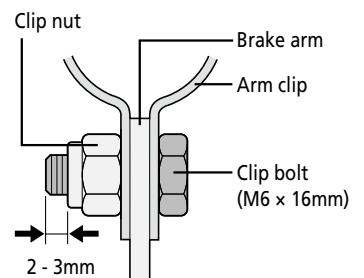

- Before using the Coaster Brake, check that the brake works properly and that the wheel turns smoothly.

4



Click here for the latest Dealer's Manual



<https://si.shimano.com/DM/CASG001>

Installation of the disc brake rotor

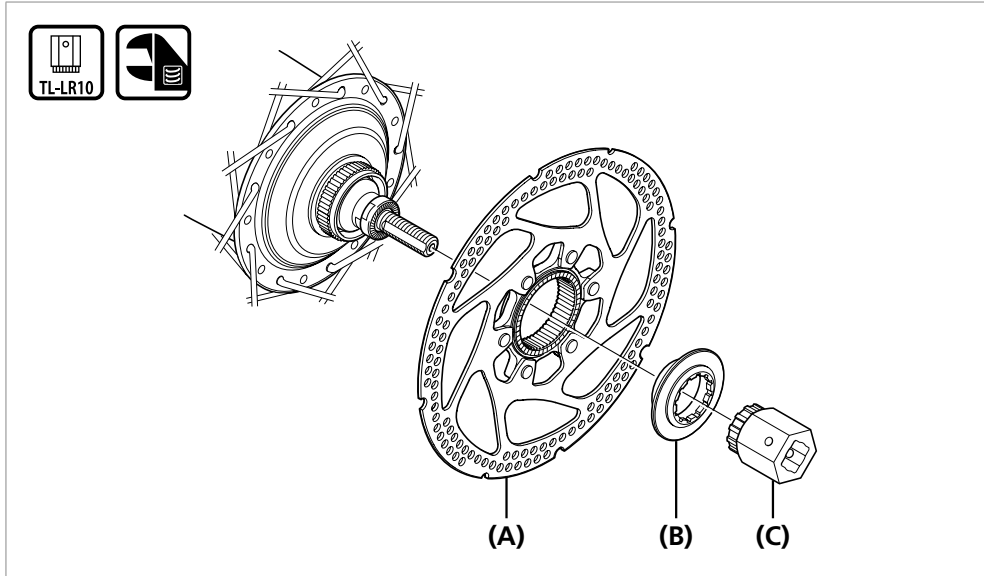
Center lock type



- (A) Disc brake rotor
- (B) Disc brake rotor fixing lock ring
- (C) TL-LR10

Tightening torque	
 	40 N·m



Click here for the latest Dealer's Manual

<https://si.shimano.com/DM/CASG001>

5 bolt type (with lock washer)

1

Attach the disc brake rotor and the disc brake rotor lock washers to the hub, and then tighten them on with the bolts.

- (A) Lock washer
- (B) Disc brake rotor fixing bolt

Tightening torque	
	2 - 4 N·m

NOTICE

- Fit the lock washers so that the marking "TOP" is visible.
- Ensure that the hooked parts of the lock washer are securely caught on the notches in the disc brake rotor and then tighten on the lock washer with the disc brake rotor fixing bolt. If tightened while the hooked parts are against the surface of the disc brake rotor, the washer and its hooked parts will become deformed.

Hooked part of washer

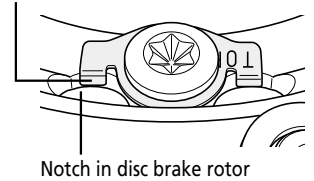

- The lock washers are not reusable. Always use new lock washers when installing/re-installing the disc brake rotor.
- Use the dedicated disc brake rotor fixing bolts.

2

Wear gloves and turn the disc brake rotor clockwise with some force.

At this time, tighten on the disc brake rotor fixing bolts in the order indicated in the illustration.





Click here for the latest Dealer's Manual

<https://si.shimano.com/DM/CASG001>

Installation of the lever

When equipped with mode switching mechanism

1





Use screwdriver[#1] to loosen the screw.

2



Set the mode switch to the mode position for the brake installed.

 **TECH TIPS**

For V-BRAKE brakes



For caliper brakes/cantilever brakes/roller brakes



Installation of the lever

Install the lever as shown in the illustration.

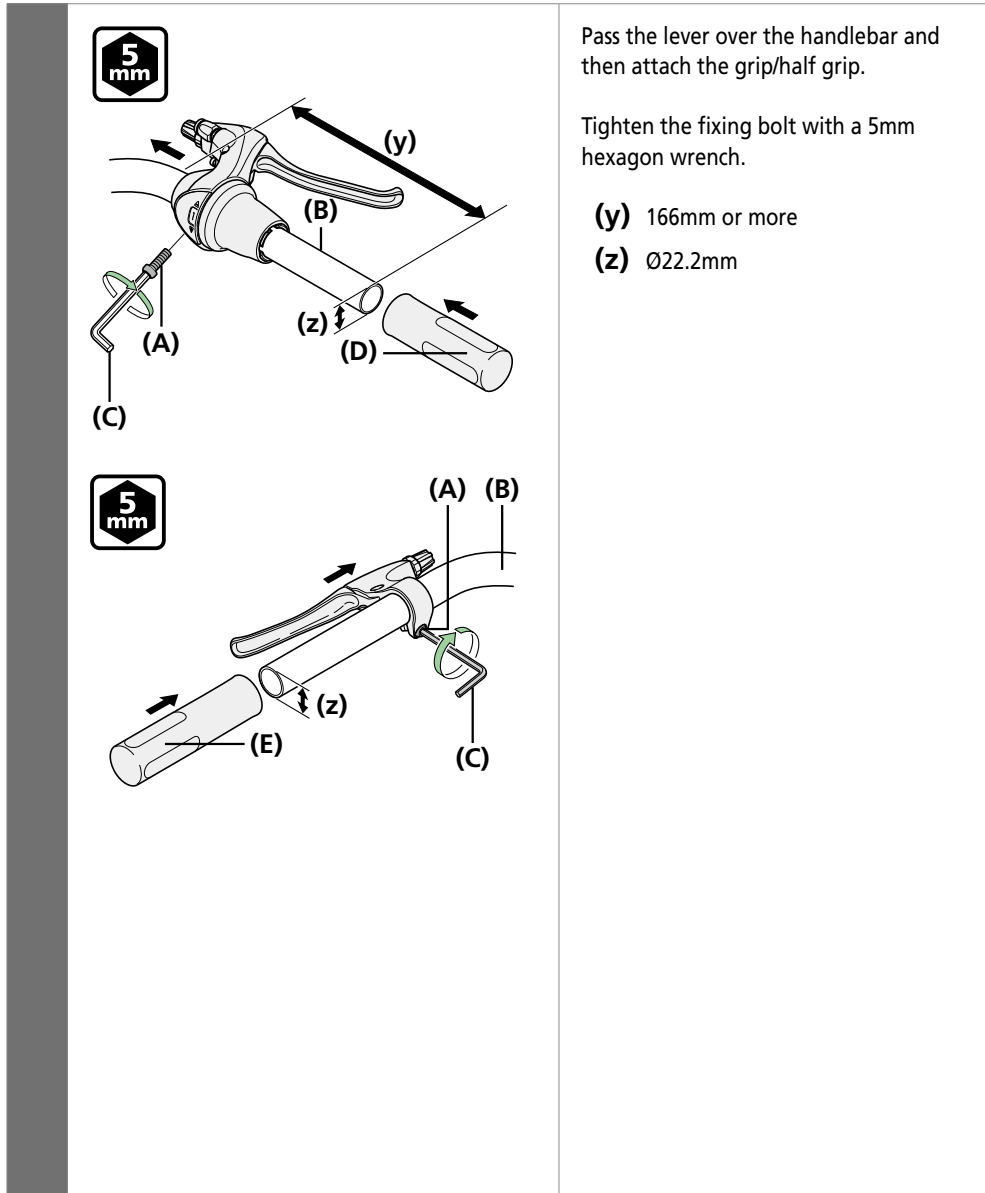

Pass the lever over the handlebar and then attach the grip/half grip.

Tighten the fixing bolt with a 5mm hexagon wrench.

(y) 166mm or more

(z) Ø22.2mm

- (A) Fixing bolt
- (B) Handlebar
- (C) 5mm hexagon wrench
- (D) Half grip
- (E) Grip

Tightening torque



6 - 8 N·m

NOTICE

When using SL-C6000/SL-C3000, make sure to install the handlebar with the grip spacer attached.

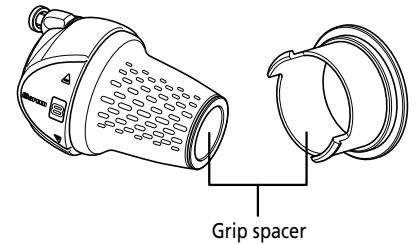

TECH TIPS

- If using Shimano half grip, the straight section of the handlebar should be 166mm or longer. Attach the REVOSHIFT lever to this straight section.
- Leave a gap of 0.5mm between the REVOSHIFT lever and the half grip.

Installation of the shifting cable

For information on how to replace the inner cable, refer to the maintenance section.

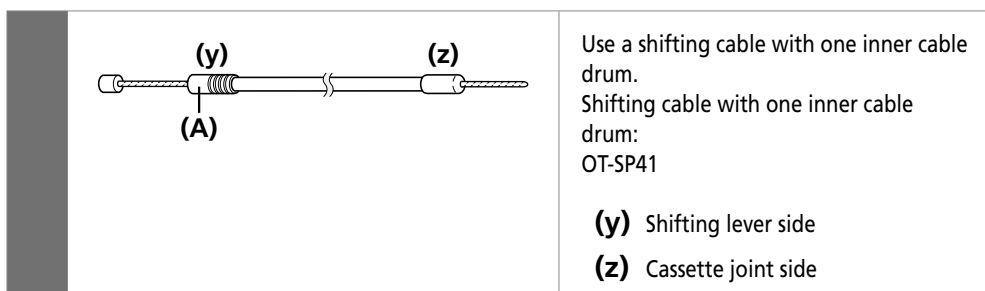

Use a shifting cable with one inner cable drum.

Shifting cable with one inner cable drum:
OT-SP41

(y) Shifting lever side

(z) Cassette joint side

- (A) Sealed outer cap

NOTICE

Make sure that the sealed outer cap is at the shifting lever end.



Click here for the latest Dealer's Manual

<https://si.shimano.com/DM/CASG001>

■ Installing to the cassette joint

For CJ-NX10/CJ-8S20

1

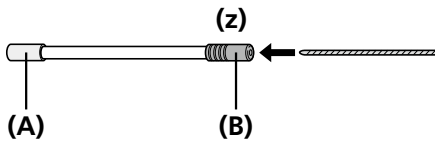

Pass the inner cable through the OT-SP41 outer casing to the end with the plastic cap.

(z) Lever side

(A) Aluminum cap

(B) Plastic cap



Cutting the outer casing

If cutting the outer casing, cut it near the end with the plastic cap while the cap is still attached.

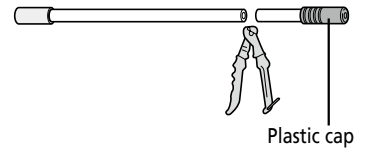

After cutting, make the cut end perfectly round and attach the plastic cap.

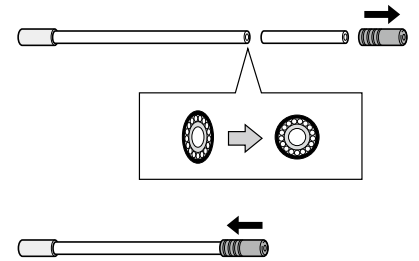

2

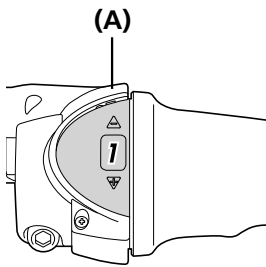

Set the REVOSHIFT lever to 1.

(A) REVOSHIFT lever



Click here for the latest Dealer's Manual

<https://si.shimano.com/DM/CASG001>

3

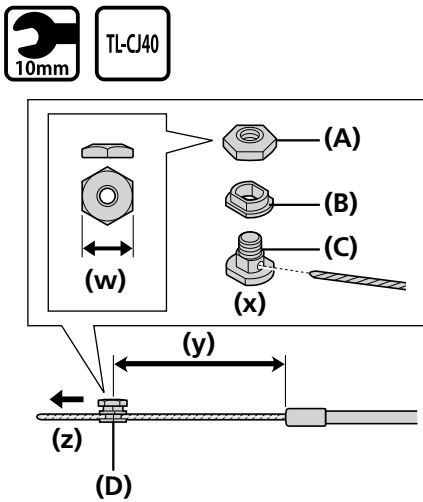

After checking that the end of the outer casing is securely set in the cable adjustment barrel of the REVOSHIFT lever, attach the inner cable mounting bolt unit to the inner cable.

- (w) 10mm
- (x) Pass the inner cable through the hole.
- (y) 101mm
- (z) Pull the inner cable when securing.

- (A) Inner cable mounting nut (Black)
- (B) Inner cable mounting washer (Silver)
- (C) Inner cable mounting bolt (Silver)
- (D) Inner cable mounting bolt unit

Tightening torque



3.5 - 5.5 N·m

NOTICE

- This inner cable mounting bolt unit is designed only for CJ-NX10, CJ-NX40, CJ-8S20, and CJ-8S40. 11-speed mounting bolt units cannot be used.
- The tool is shipped ready to be used for CJ-NX10 and CJ-8S20.
- When installing the inner cable mounting bolt unit, use the setting tool TL-CJ40 (Y70898020).
- For CJ-NX10 and CJ-8S20, use the front side of TL-CJ40.

Front side of TL-CJ40

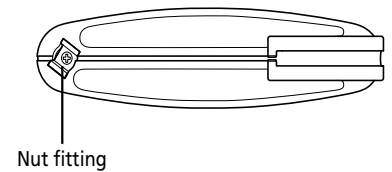

Click here for the latest Dealer's Manual

<https://si.shimano.com/DM/CASG001>

4

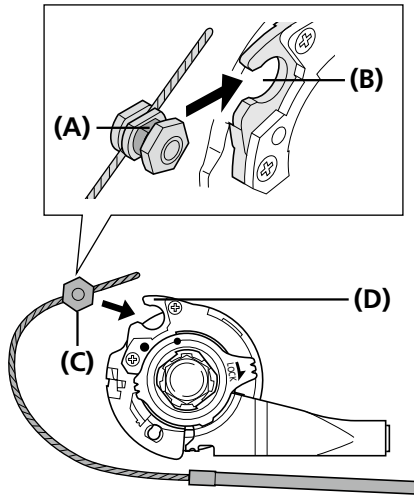

Bring the cable around to the cassette joint pulley, hold it so that the inner cable fixing nut is facing outwards (towards the fork end), and then slide the flats part of the inner cable fixing washer into the gap in the pulley.

- (A) Flats part of inner cable fixing washer
- (B) Gap in pulley
- (C) Inner cable fixing nut
- (D) Pulley

5

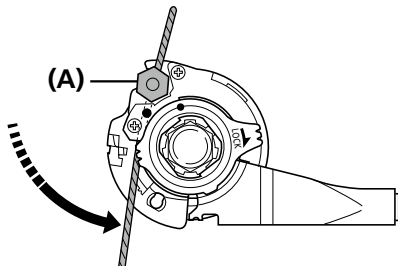

Turn the cable 60° counterclockwise and attach it to the hook.

- (A) Hook



6

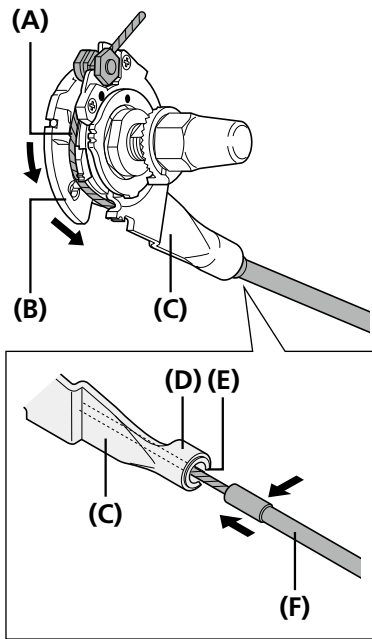

Attach the inner cable to the pulley as shown in the illustration, pass the inner cable through the slit in the bracket, and then insert the end of the outer casing securely into the outer casing holder.

- (A) Inner cable
- (B) Pulley
- (C) Bracket
- (D) Outer casing holder
- (E) Slit
- (F) Outer casing

NOTICE

Check that the inner cable is correctly seated inside the pulley guide.

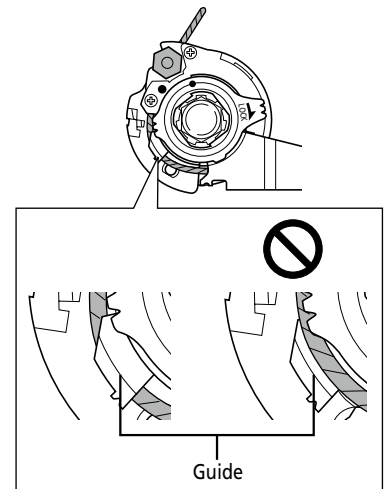

When inserting outer casing into outer casing holder first

6

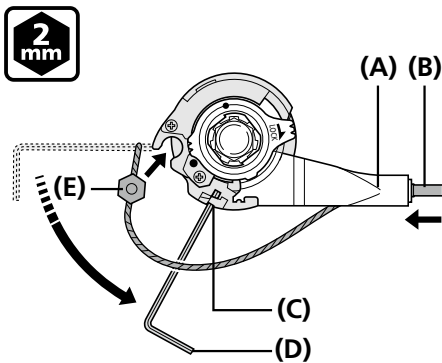

Insert the outer casing into the outer casing holder.

Insert a 2mm hexagon wrench or a #14 spoke into the hole in the pulley, and then turn the pulley.

Fit the inner cable mounting bolt unit into the gap in the pulley.

- (A) Outer casing holder
- (B) Outer casing
- (C) Hole in pulley
- (D) 2mm hexagon wrench or #14 spoke
- (E) Inner cable mounting bolt unit

7

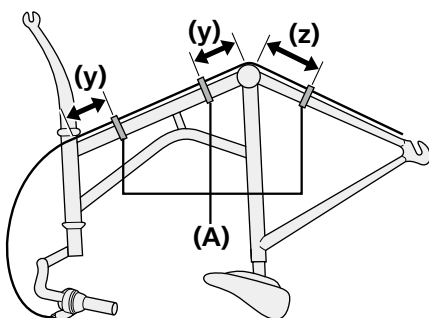

Secure the cable to the frame with the outer casing bands.

- (y) 10cm
- (z) 15cm

- (A) Outer casing bands



Click here for the latest Dealer's Manual

<https://si.shimano.com/DM/CASG001>

For CJ-NX40/CJ-8S40

1

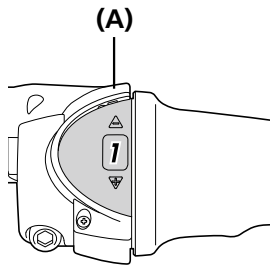

Set the REVOSHIFT lever to 1.

(A) REVOSHIFT lever

2

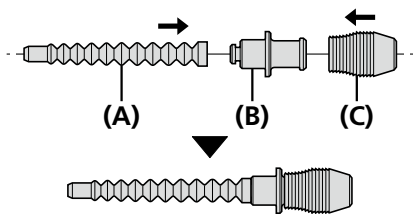

Install the rubber cover and rubber bellows to the outer casing holder.

(A) Rubber bellows
(B) Outer casing holder
(C) Rubber cover

3

Wipe off any grease on the inner cable.

NOTICE

Use a new inner cable; do not use a cable which has had its end cut off.



4

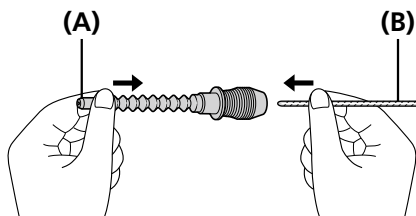

While holding the end of the rubber bellows, insert the inner cable.

(A) End of rubber bellows
(B) Inner cable

NOTICE

Be careful not to pierce the rubber bellows with the end of the inner cable at this time.

5

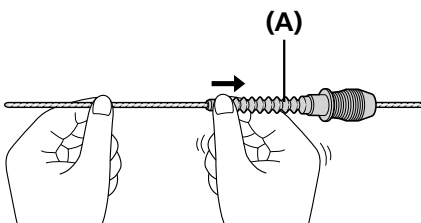

Slide the rubber bellows onto the inner cable.

(A) Rubber bellows



Click here for the latest Dealer's Manual

<https://si.shimano.com/DM/CASG001>

6

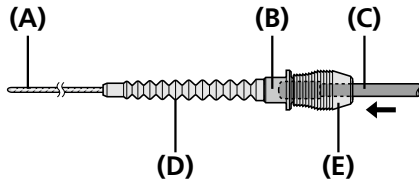

Insert the outer casing into the rubber cover and set it into the outer casing holder.

Push the outer casing so that it securely touches the holder.

- (A) Inner cable
- (B) Outer casing holder
- (C) Outer casing
- (D) Rubber bellows
- (E) Rubber cover

7

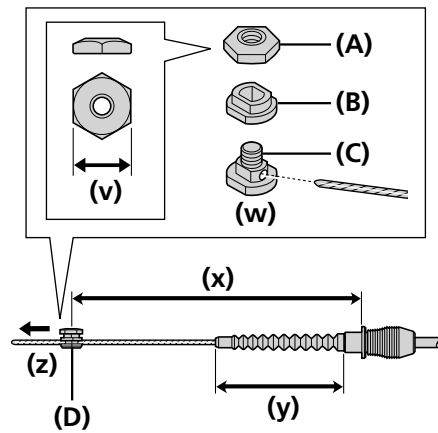

After checking that the end of the outer casing is securely set in the cable adjustment barrel of the shifting lever, attach the inner cable mounting bolt unit to the inner cable.

- (v) 10mm
- (w) Pass the inner cable through the hole
- (x) 127mm
- (y) 63mm or less
- (z) Pull the inner cable when securing

- (A) Inner cable mounting nut (Black)
- (B) Inner cable mounting washer (Silver)
- (C) Inner cable mounting bolt (Silver)
- (D) Inner cable mounting bolt unit

Tightening torque



3.5 - 5.5 N·m

NOTICE

- This inner cable mounting bolt unit is designed only for CJ-NX10, CJ-NX40, CJ-8S20, and CJ-8S40. 11-speed mounting bolt units cannot be used.
- The tool is shipped ready to be used for CJ-NX10 and CJ-8S20.
- When installing the inner cable mounting bolt unit, use the setting tool TL-CJ40 (Y70898020).
- For CJ-NX40 and CJ-8S40, use the reverse side of TL-CJ40. Replace the nut fitting as shown in the illustration.

Reverse side of TL-CJ40

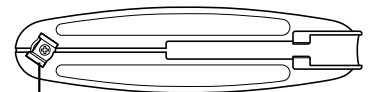

Nut fitting



Click here for the latest Dealer's Manual

<https://si.shimano.com/DM/CASG001>

8

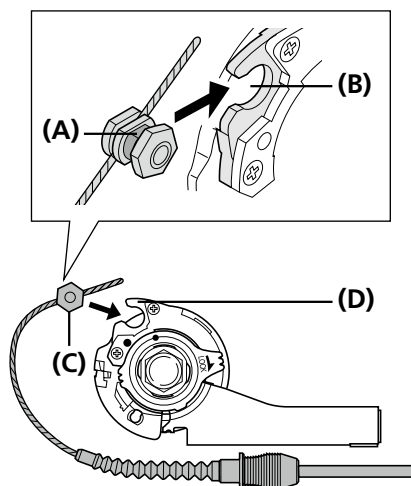

Bring the cable around to the cassette joint pulley, hold it so that the inner cable fixing nut is facing outwards (towards the fork end), and then slide the flats part of the inner cable fixing washer into the gap in the pulley.

- (A) Flats part of inner cable fixing washer
- (B) Gap in pulley
- (C) Inner cable fixing nut
- (D) Pulley

9

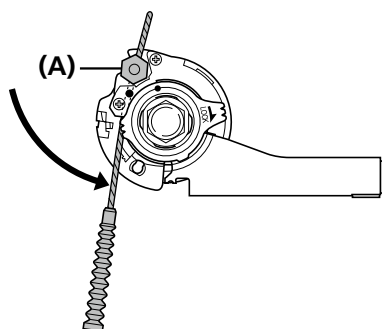

Turn the cable 60° counterclockwise and attach it to the hook.

- (A) Hook



10

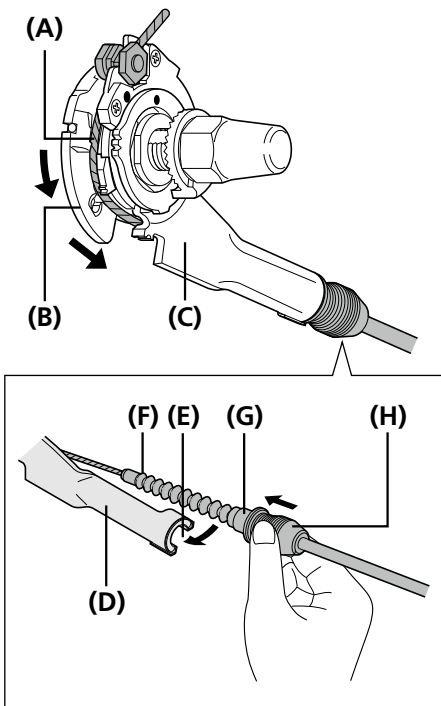

Mount the inner cable into the pulley as shown in the illustration.

Holding the rubber cover, insert the rubber bellows part of the inner cable into the slit in the cassette joint bracket.

Next, insert the outer casing holder securely into the outer casing holder section of the cassette joint.

Be careful not to damage the rubber bellows at this time.

- (A) Inner cable
- (B) Pulley
- (C) Bracket
- (D) Outer casing holder section
- (E) Slit
- (F) Rubber bellows
- (G) Outer casing holder
- (H) Rubber cover

NOTICE

Check that the inner cable is correctly seated inside the pulley guide.

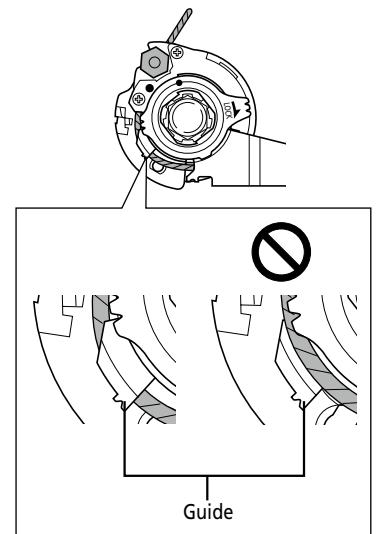

When inserting outer casing holder into outer casing holder section of cassette joint

10

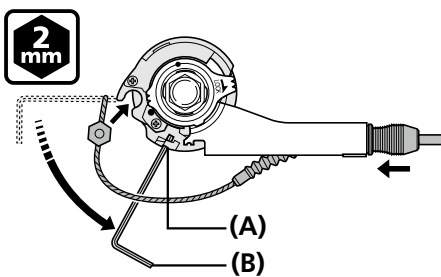

Insert the outer casing holder into the outer casing holder section of the cassette joint.

Insert a 2mm hexagon wrench or a #14 spoke into the hole in the pulley, and then turn the pulley.

Fit the inner cable mounting bolt unit into the gap in the pulley.

- (A) Hole in pulley
- (B) 2mm hexagon wrench or #14 spoke



Click here for the latest Dealer's Manual

<https://si.shimano.com/DM/CASG001>

11

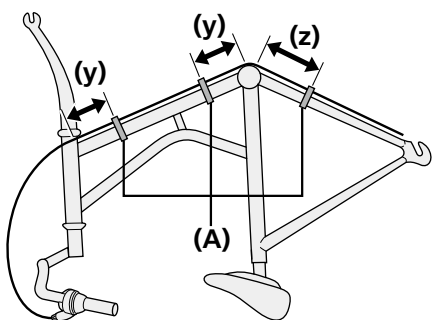

Finally, fix the cable on the frame with the outer casing bands.

(y) 10cm

(z) 15cm

(A) Outer casing bands



ADJUSTMENT

Adjusting the cassette joint

1

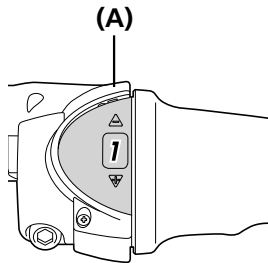

Set the REVOSHIFT lever to 1.

(A) REVOSHIFT lever

2

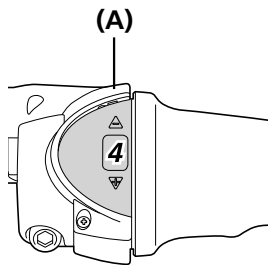

Set the REVOSHIFT lever to 4.

(A) REVOSHIFT lever

NOTICE

When setting, do so gradually and with minimal force so as to avoid over-shifting. If you over-shift, the setting line will not return to the proper position, and the setting lines may not be aligned at the correct position. (Refer to procedure 3)

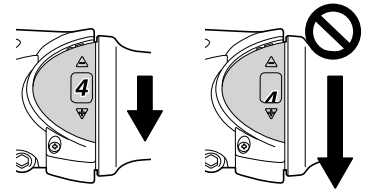

3

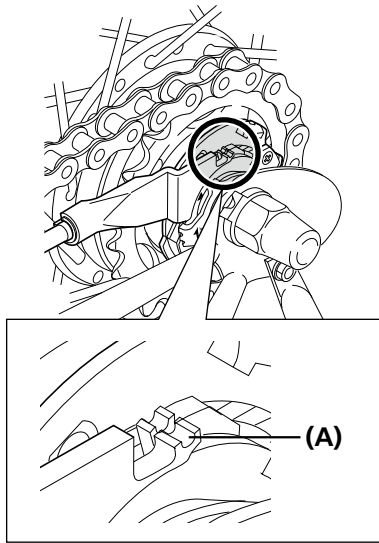

Check that the yellow setting lines on the cassette joint bracket and pulley are aligned with each other.

(A) Yellow setting lines

NOTICE

If the overlapping area falls short of two thirds of each setting line, the gears may not be properly engaged during pedaling, resulting in abnormal noise or free spinning of the pedals.

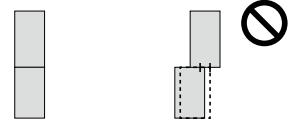

TECH TIPS

The yellow setting lines on the cassette joint are located in two places. Use the one that is easiest to see.

When the bicycle is upright

Should be aligned

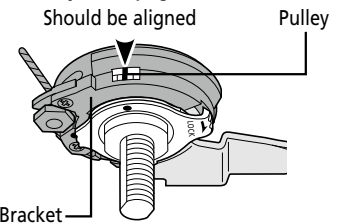

When the bicycle is upside down

Should be aligned

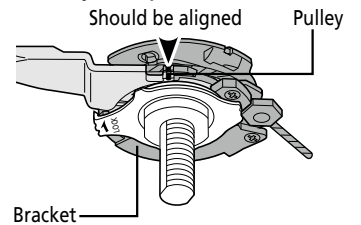

Click here for the latest Dealer's Manual

<https://si.shimano.com/DM/CASG001>

If the yellow setting lines are not aligned

3

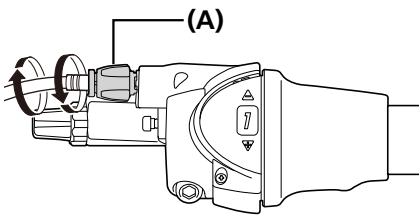

(A)

Turn the cable adjustment barrel of the REVOSHIFT lever to align the setting lines.

Again, move the REVOSHIFT lever from X to Y, then back to X, and confirm that the yellow setting lines are aligned.

	X	Y
8-speed	4	1

(A) Cable adjustment barrel

4

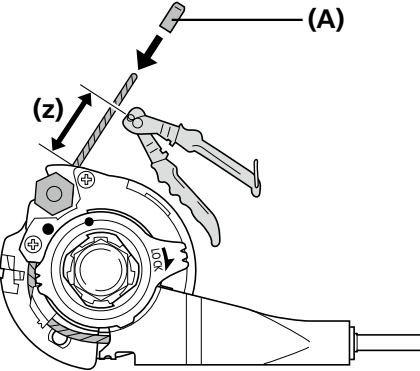

(A)

(z)

After adjusting the cassette joint, cut off the excess length of inner cable.

Next, install the inner end cap.

(z) 15 - 20mm

(A) Inner end cap



MAINTENANCE

■ Disconnecting the shifting cable when removing the rear wheel from the frame

For CJ-NX10/CJ-8S20

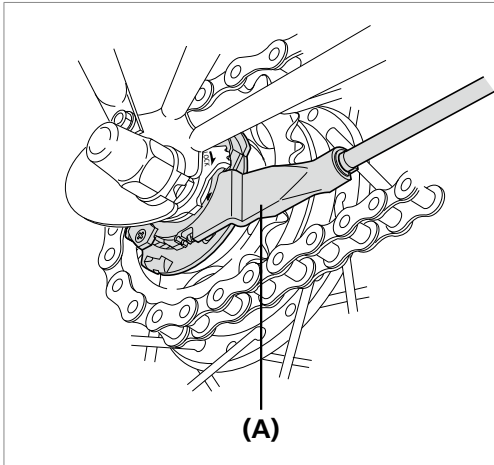

Disconnect the cable from the cassette joint when removing the rear wheel from the frame.

(A) Cassette joint

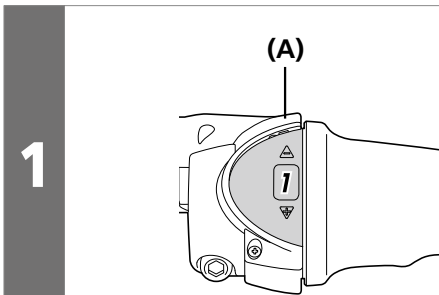

1

Set the REVOSHIFT lever to 1.

(A) REVOSHIFT lever

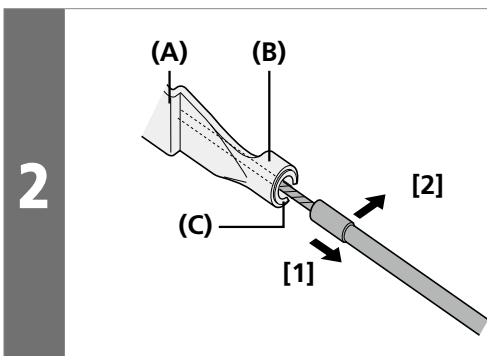

2

Pull out the outer casing from the outer casing holder of the cassette joint, and remove the inner cable from the slit in the bracket.

(A) Bracket
(B) Outer casing holder
(C) Slit



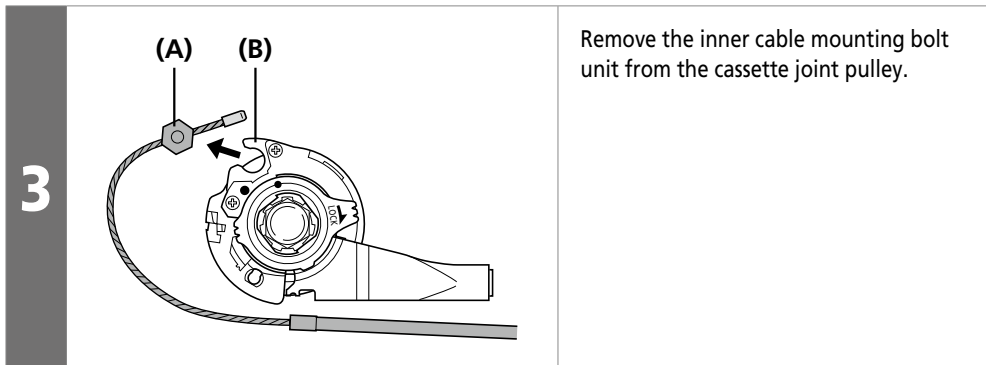

Remove the inner cable mounting bolt unit from the cassette joint pulley.

- (A) Inner cable mounting bolt unit
- (B) Cassette joint pulley

When it is difficult to remove the outer casing from the outer casing holder of the cassette joint

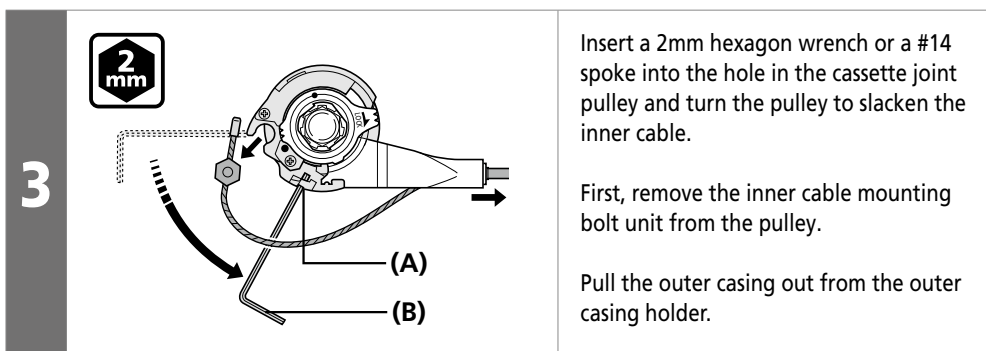

Insert a 2mm hexagon wrench or a #14 spoke into the hole in the cassette joint pulley and turn the pulley to slacken the inner cable.

First, remove the inner cable mounting bolt unit from the pulley.

Pull the outer casing out from the outer casing holder.

- (A) Hole in pulley
- (B) 2mm hexagon wrench or #14 spoke



When remounting the cable, refer to the section "Installation of the shifting cable".



For CJ-NX40/CJ-8S40

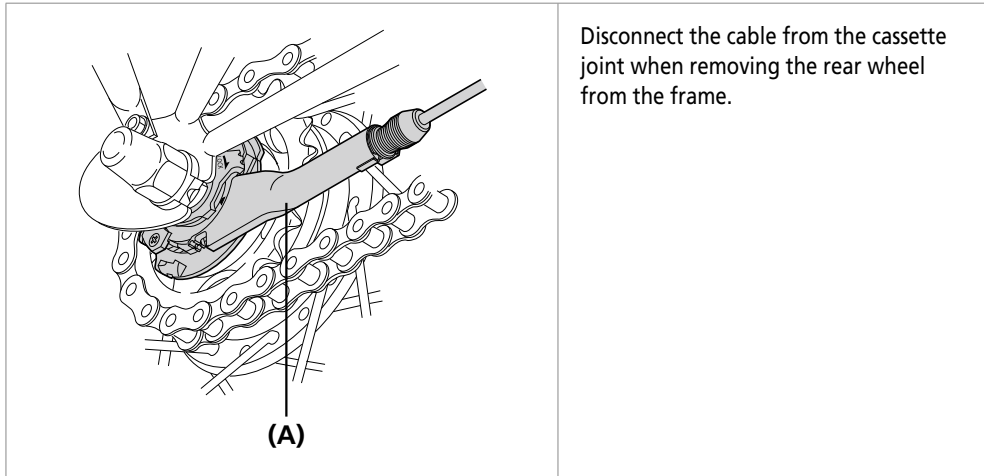

Disconnect the cable from the cassette joint when removing the rear wheel from the frame.

(A) Cassette joint

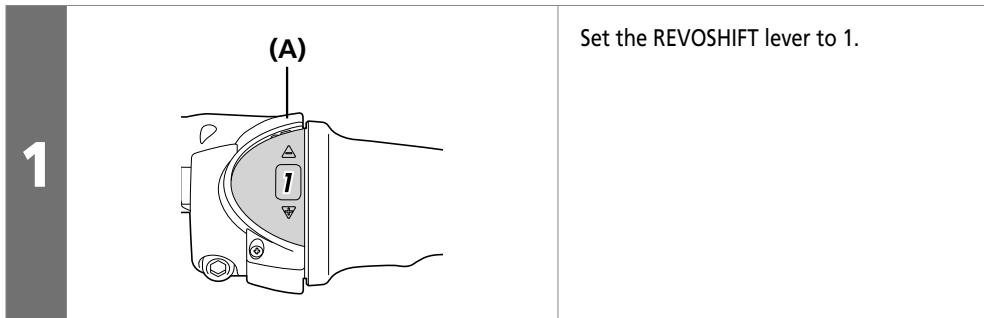

Set the REVOSHIFT lever to 1.

(A) REVOSHIFT lever

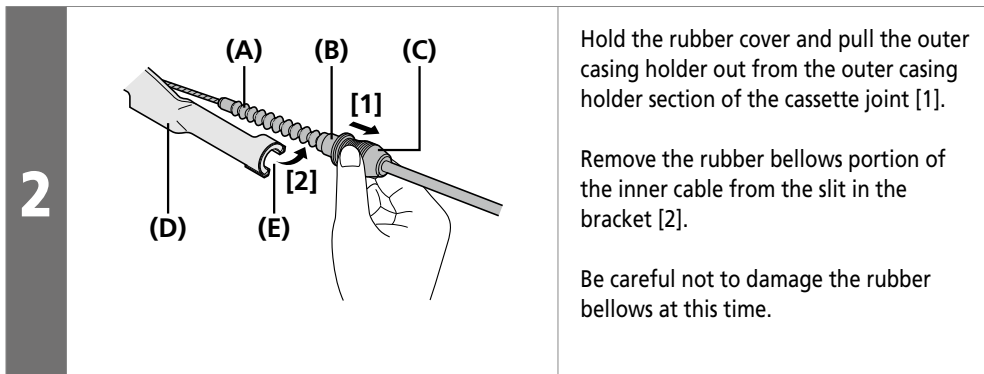

Hold the rubber cover and pull the outer casing holder out from the outer casing holder section of the cassette joint [1].

Remove the rubber bellows portion of the inner cable from the slit in the bracket [2].

Be careful not to damage the rubber bellows at this time.

- (A) Rubber bellows
- (B) Outer casing holder
- (C) Rubber cover
- (D) Outer casing holder section
- (E) Slit

NOTICE

Do not remove the cable by pulling the outer casing.

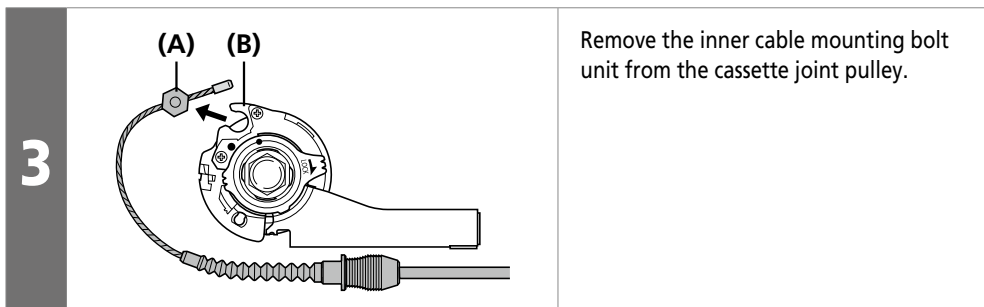

Remove the inner cable mounting bolt unit from the cassette joint pulley.

- (A) Inner cable mounting bolt unit
- (B) Cassette joint pulley

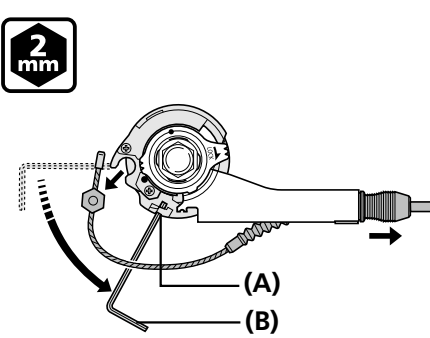

When it is difficult to remove the outer casing holder from the outer casing holder section of the cassette joint

3		<p>Insert a 2mm hexagon wrench or a #14 spoke into the hole in the cassette joint pulley and turn the pulley to slacken the inner cable.</p>	<p>(A) Hole in pulley (B) 2mm hexagon wrench or #14 spoke</p>
		<p>First, remove the inner cable mounting bolt unit from the pulley.</p> <p>Pull the outer casing holder out from the outer casing holder section.</p>	



4

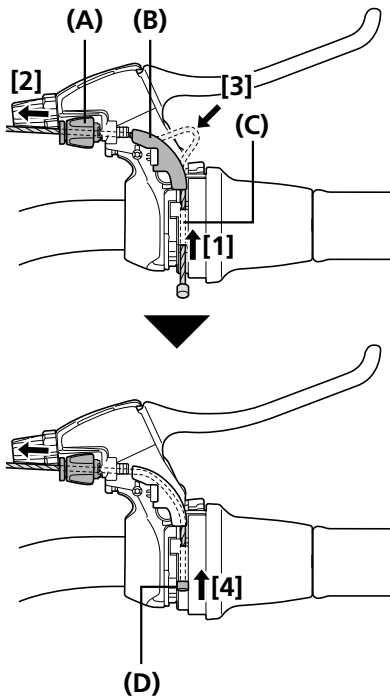

Pass the inner cable from the hole in the winder unit through the hole in the cable adjustment barrel.

Next, insert the inner cable into the groove of the cable guide.

Next, pull the inner cable so that the inner cable drum fits into the recess in the winder unit.

- (A) Hole in cable adjustment barrel
- (B) Groove of cable guide
- (C) Hole in winder unit
- (D) Recess in winder unit

5

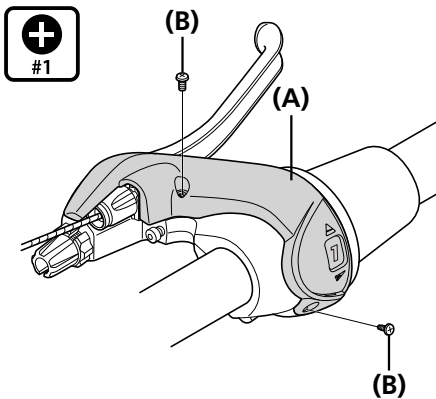

Replace the cover and tighten the cover fixing screws.

- (A) Cover
- (B) Cover fixing screw

Tightening torque	
	0.1 - 0.2 N·m



Oil maintenance of the internal assembly

To maintain the product in good working order, it is recommended to have the place of purchase or a distributor carry out maintenance such as lubrication of the internal parts about once a year from the first time of use (once every 2,000 km if the bicycle is used very frequently). If the bicycle is used under harsh conditions, more frequent maintenance is required. Also, for carrying out maintenance, the use of SHIMANO internal geared hub grease or a lubrication kit is recommended. If SHIMANO grease or a SHIMANO lubrication kit is not used, problems such as a malfunction in gear shifting may occur.

(A) WB maintenance oil set
(Y00298010)



(A)

1



Fill the container with maintenance oil to a height of 95mm.

(z) 95mm

2



Immerse the internal unit in the oil from the left side until the oil reaches up to ring gear unit 1, as shown in the illustration.

(z) Ring gear unit 1

3



Keep the internal unit immersed for approximately 90 seconds.



4



Remove the internal unit from the oil.

5



Let excess oil drain off for approximately 60 seconds.

6



Reassemble the hub.





Dealer's Manual

SG-C6011-8R
SG-C6011-8V
SG-C6001-8R
SG-C6001-8V
SG-C6001-8C
SG-C6001-8D
SG-C6001-8CD

Installation of sprocket to the hub

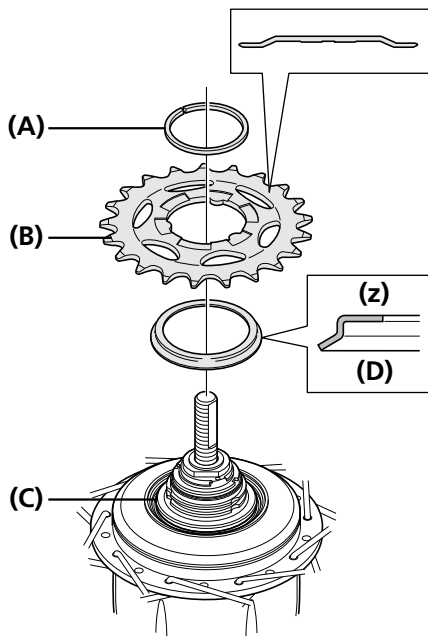

Place right-hand dust cap onto the driver on the right side of the hub body.

Next, install the sprocket and secure it in place with the snap ring.

(z) Note the direction

- (A) Snap ring
- (B) Sprocket
- (C) Driver
- (D) Right-hand dust cap B

NOTICE

This product should only be used with inward assembling sprockets with 18T to 23T.

Installation of the motor unit to the hub (MU-UR500/MU-S705)

Unless otherwise noted, MU-UR500 is used as an example for this explanation.

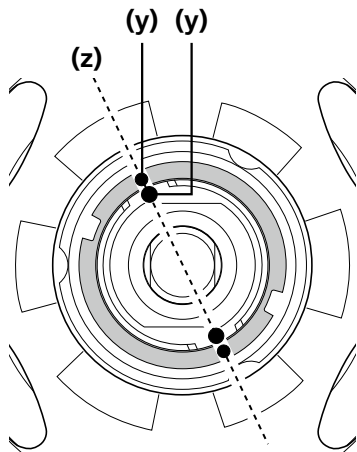

Check that the two • marks (red) on the right side of the hub body are aligned.

- (y) • mark (red)
- (z) Should be aligned

TECH TIPS

If the two • marks (red) are not aligned, use the TL-SGE1 to align the two • marks (red).

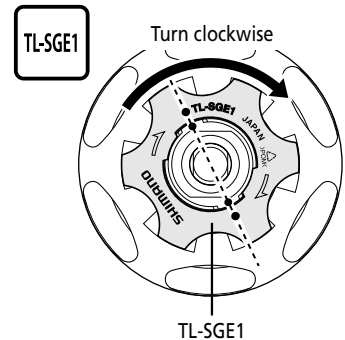

Click here for the latest Dealer's Manual

<https://si.shimano.com/DM/AL0001>

Make sure that the two protrusions on the reverse side of the motor unit are at the initial positions.

- For MU-UR500, confirm that the mark and protrusions are aligned.
- For MU-S705, confirm that the protrusions are positioned as shown in the illustration.

MU-UR500

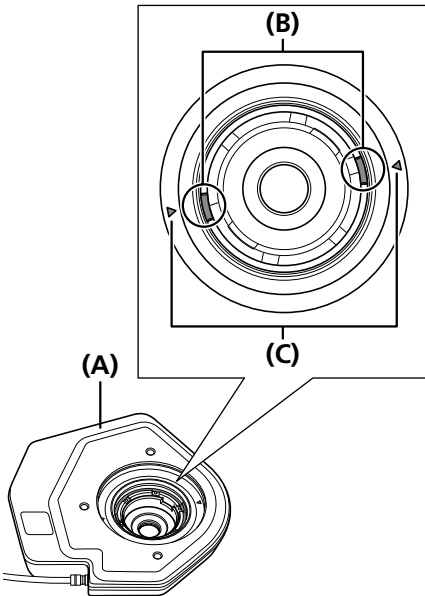

MU-S705

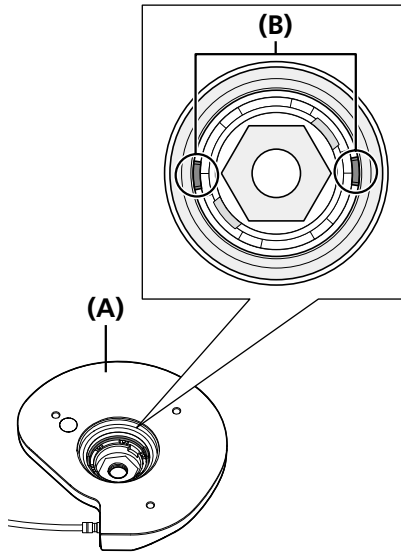

2

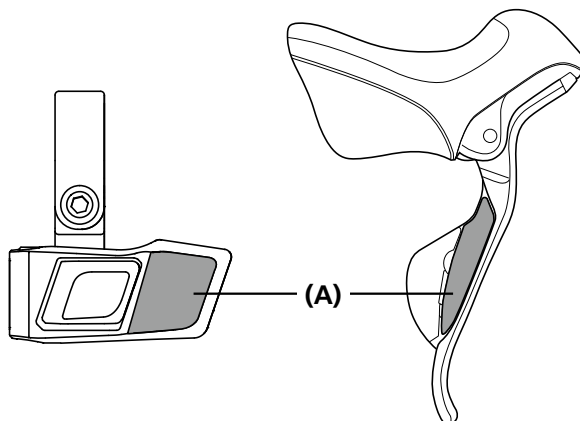

- (A) Reverse side of motor unit
- (B) Protrusion
- (C) Mark (MU-UR500)

NOTE

Check that the rubber seal is attached. If the rubber seal is not attached, attach as shown in the illustration. There is no compatibility between MU-UR500 and MU-S705 rubber seals.

MU-UR500

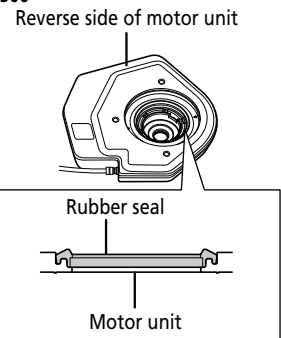

MU-S705

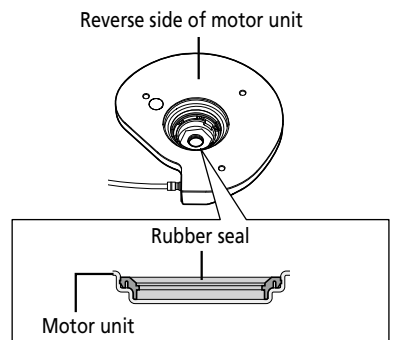

- (A) Shifting switch

NOTICE

The motor unit is set at the initial position when it is shipped; therefore, install it without changing the position. If the motor unit may not be at the initial position, push the following shifting switch ten or more times to move the protrusions on the motor unit clockwise (check from the back side of the motor unit). (Check the shifting up and down of the shifting switch in advance as it may have been switched by customization.) If the motor unit is installed off the initial position, some gears may become unavailable and the hub or the motor unit may be damaged.



Click here for the latest Dealer's Manual

<https://si.shimano.com/DM/AL0001>

3

Install the motor unit to the hub so that the ● mark (x) on the motor unit is aligned with the ● mark (y) on the hub lock spacer.

After this, gently push the motor unit while turning it slowly to set it correctly until it stops turning on the hub axle.

Next, secure the motor unit by tightening right-hand lock nut B.

- (x) motor unit ● mark
MU-UR500: Silver
MU-S705: Yellow
- (y) hub lock spacer ● mark (red)
This is the mark for which the position was aligned in step 1.
- (z) Outer side

- (A) Right-hand lock nut B
- (B) Right-hand lock nut A
- (C) Motor unit

Tightening torque	
	6 - 10 N·m

NOTICE

Check that the guide of right-hand lock nut A is seated securely in the guide hole on the front of the motor unit.

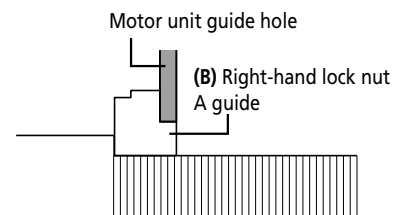

Installation of the disc brake rotor

Install the disc brake rotor as shown in the illustration.

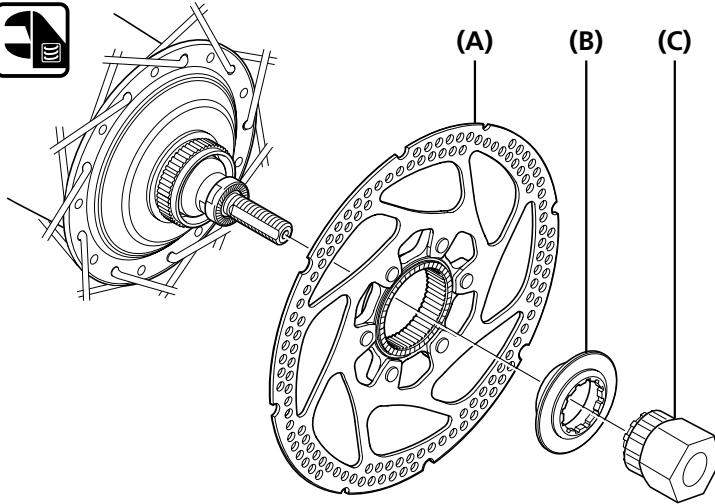

- (A) Disc brake rotor
- (B) Disc brake rotor installation ring
- (C) TL-LR10

Tightening torque



40 N·m



Click here for the latest Dealer's Manual

<https://si.shimano.com/DM/AL0001>

5 bolt type (with lock washers)

Place the disc brake rotor and disc brake rotor lock washers on the hub and tighten in place with the bolts.

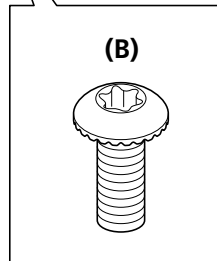
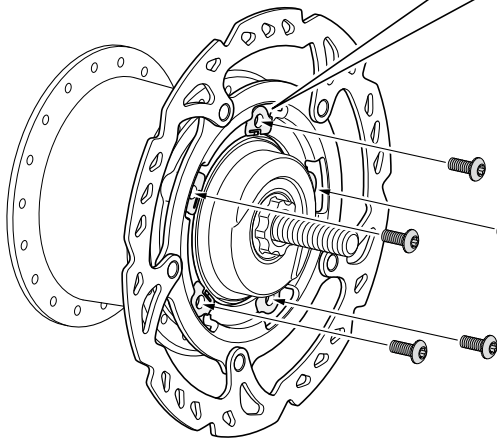
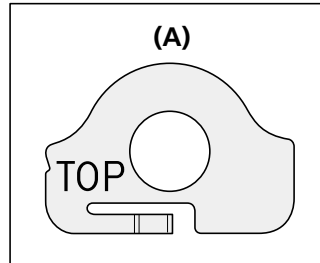

- (A) Lock washer
- (B) Disc brake rotor fixing bolt

Tightening torque



2 - 4 N·m

NOTICE

- Fit the lock washers so that the marking "TOP" is visible.
- Ensure that the hooked parts of the lock washer are securely caught on the notches in the disc brake rotor and then tighten on the lock washer with the disc brake rotor fixing bolt. If tightened while the hooked parts are against the surface of the disc brake rotor, the washer and its hooked parts will become deformed.

Hooked part of washer

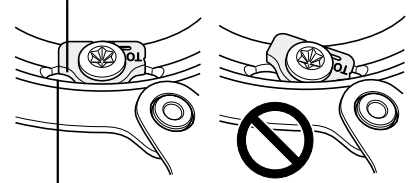

Notch in disc brake rotor

- The lock washers are not reusable. Always use new lock washers when installing/re-installing the disc brake rotor.
- Use the dedicated disc brake rotor fixing bolts.

1

2

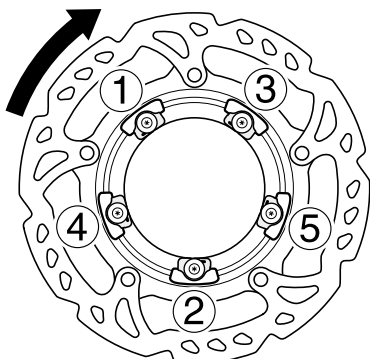

Wear gloves and turn the disc brake rotor clockwise with some force.

Then, tighten the disc brake rotor fixing bolts in the order shown in the illustration.



Click here for the latest Dealer's Manual

<https://si.shimano.com/DM/AL0001>

Installation of the hub to the frame

The method of installing the hub to the frame is the same when the chain tensioner is being used and when it is not being used.

Mount the chain on the sprocket, and then set the hub axle into the dropout.

When not using chain tensioner

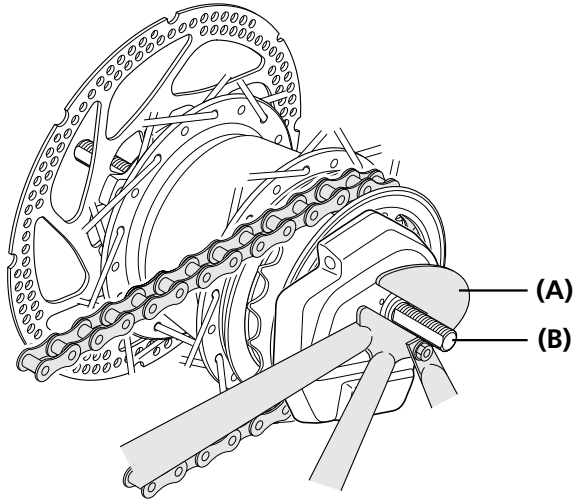

- (A) Dropout
- (B) Hub axle

1

When using chain tensioner

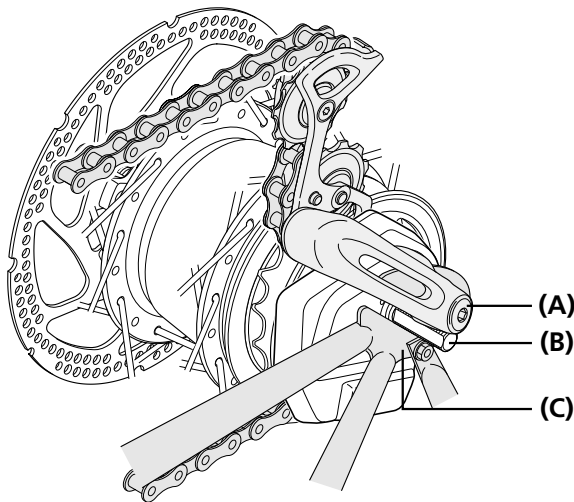

- (A) Chain tensioner
- (B) Hub axle
- (C) Dropout



When using the chain tensioner, be sure to read the attached instruction manual for the CT-S500 chain tensioner.



Click here for the latest Dealer's Manual

<https://si.shimano.com/DM/AL0001>

Place non-turn washers and onto the right and left sides of the hub axle.

At this time, turn the motor unit so that the projecting parts of the non-turn washers fit into the grooves of the dropouts.

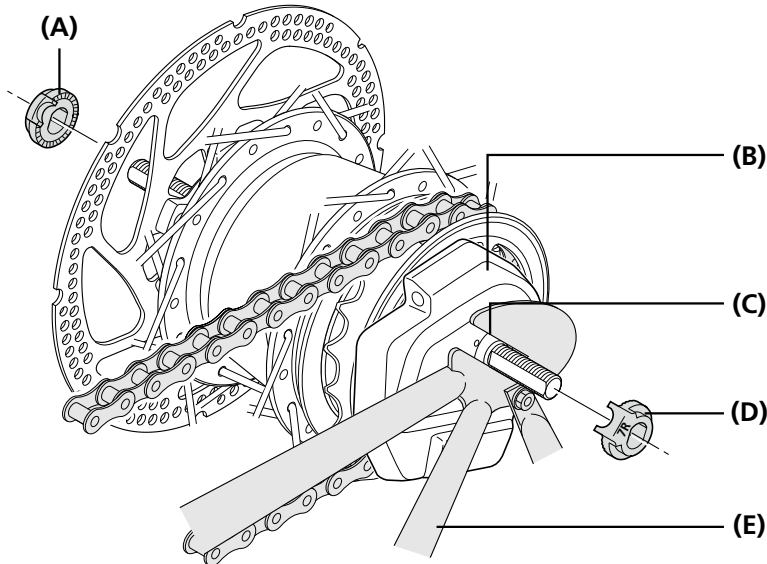

- (A) Non-turn washer (for left-side use)
- (B) Motor unit
- (C) Groove in dropout
- (D) Non-turn washer (for right-side use)
- (E) Chainstay

TECH TIPS

- Use a non-turn washer that matches the shape of the dropout. Different non-turn washers are used for the left and right sides.

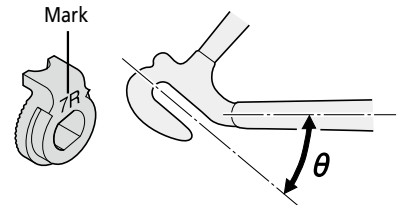

- The protrusion should be on the dropout side.
- Install the non-turn washer so that the protrusion fits securely in the dropout groove at the front and back sides of the hub axle.

2

Dropout	Non-turn washer		
	Mark/Color		Size
	For right	For left	
Standard	5R/Yellow	5L/Brown	$\theta \leq 20^\circ$
	7R/Black	7L/Gray	$\theta \leq 38^\circ$
Reversed	6R/Silver	6L/White	$\theta = 0^\circ$
Reversed (Full chain case)	5R/Yellow	5L/Brown	$\theta = 0^\circ$
Vertical	8R/Blue	8L/Green	$\theta = 60^\circ - 90^\circ$



Click here for the latest Dealer's Manual

<https://si.shimano.com/DM/AL0001>

Take up slack in the chain and secure the wheel to the frame with the hub nut.

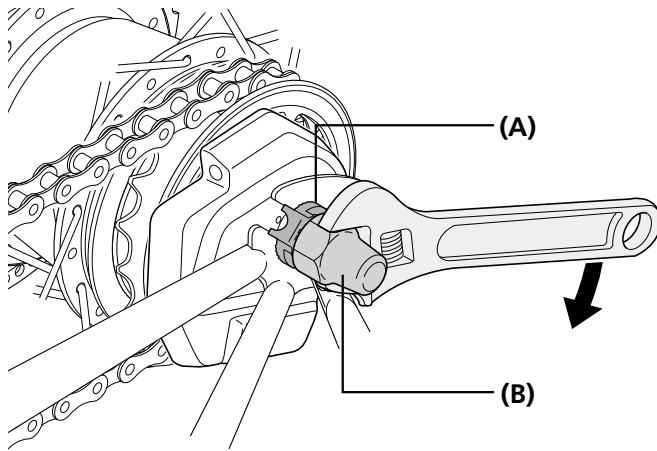

3

- (A) Non-turn washer
- (B) Hub nut

Tightening torque



30 - 45 N·m

NOTICE

- When installing parts such as a mudguard stay to the hub axle, install them in the order shown in the illustration below.

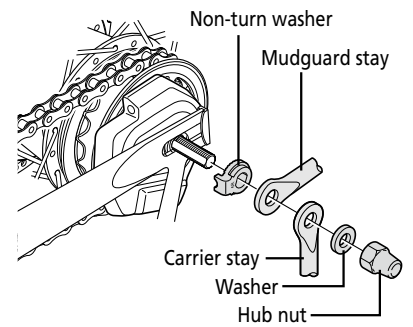

- When installing the hub to the frame, the chain guard may come off, so check that the chain guard is securely installed. If not properly installed, noise may be generated.

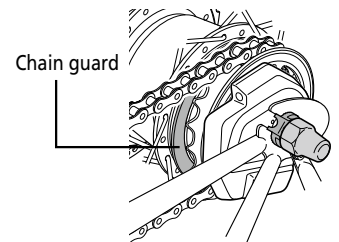

Click here for the latest Dealer's Manual

<https://si.shimano.com/DM/AL0001>

For coaster brakes

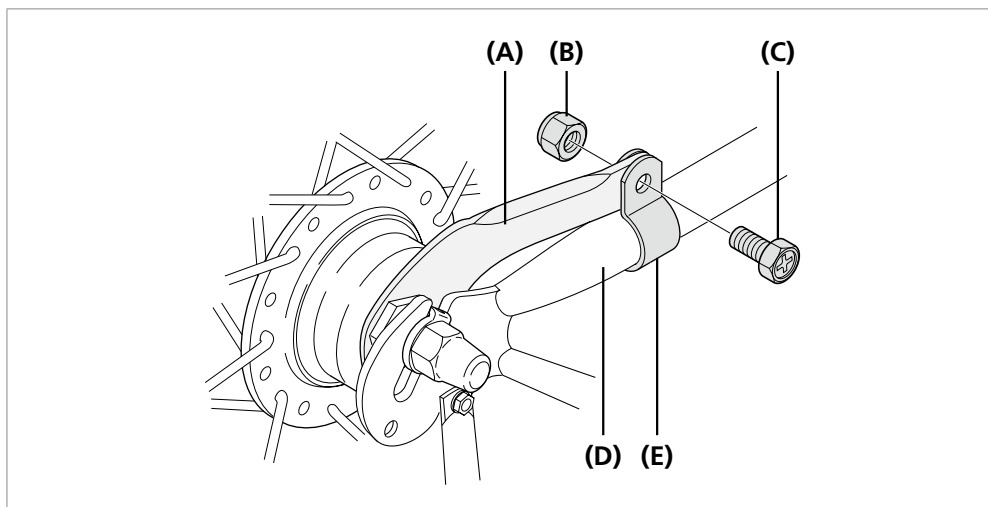

- (A)** Brake arm
- (B)** Clip nut
- (C)** Clip bolt
- (D)** Chainstay
- (E)** Arm clip



■ Connection of junction

External battery mount type (SM-JC40)

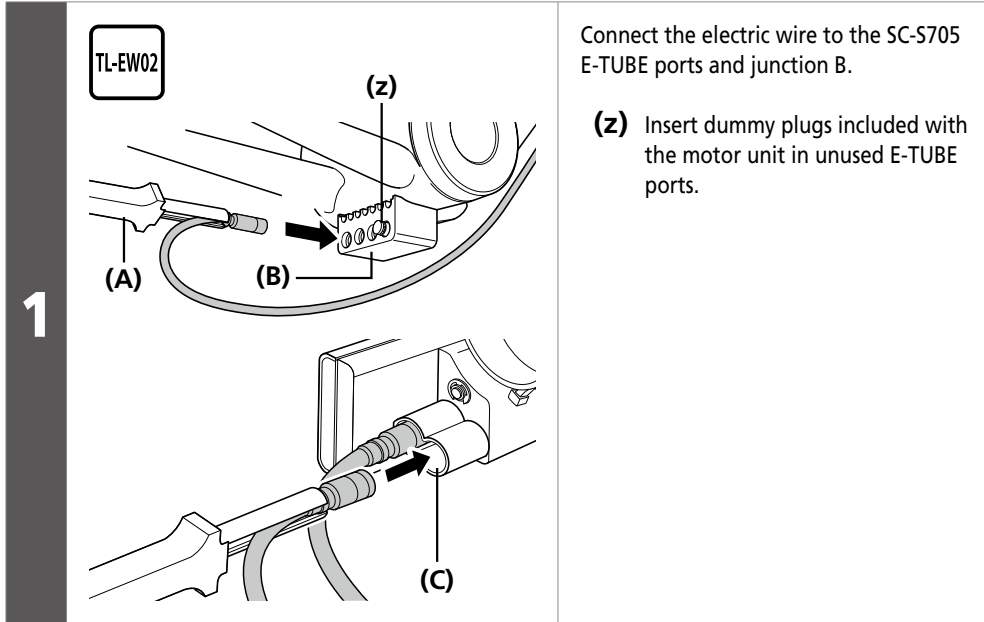

- (A) TL-EW02
- (B) Junction B
- (C) E-TUBE ports

NOTICE

Be sure to push them together until they connect with a click.

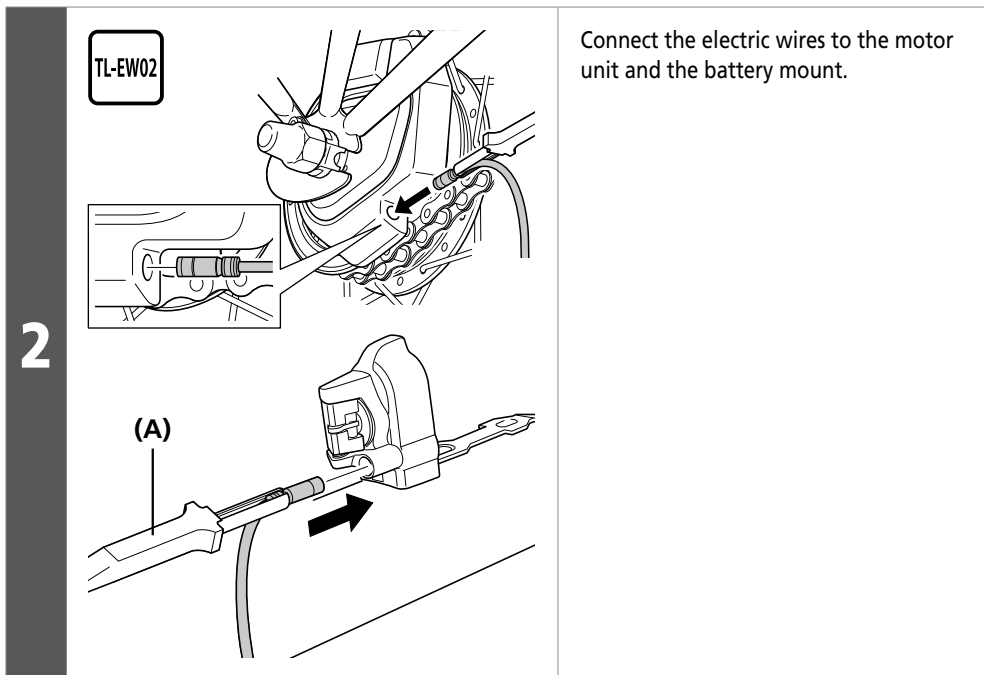

- (A) TL-EW02



3

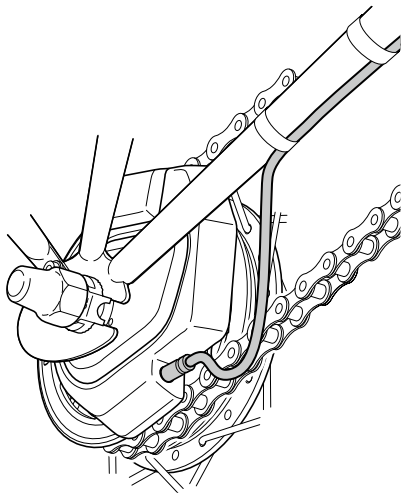

Temporarily secure the electric wire along the frame with tape, and connect it to junction B.

NOTICE

When routing the electric wire to the motor unit, be sure to install it to the bottom of the chainstay to avoid any interference between the cable and the chain.

4

Wind any excess length of electric wire inside junction B to adjust the length.

Example of adjusting junction B length

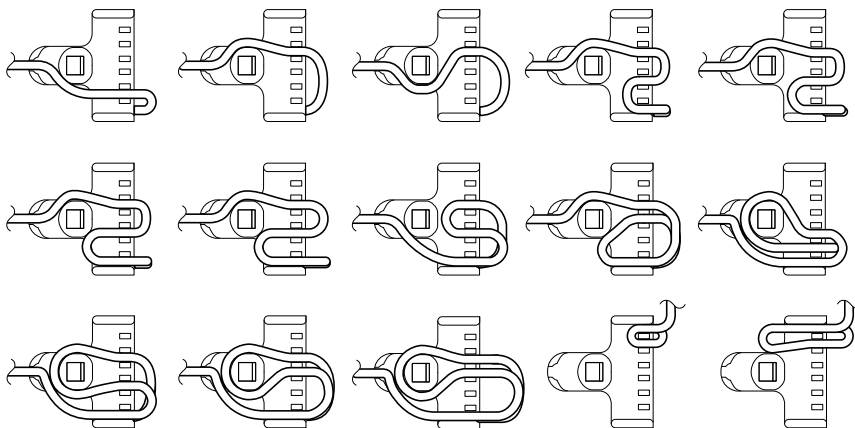

5



(A)

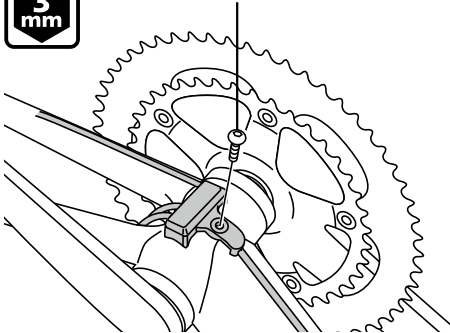

Once the electric wires have been routed, secure junction B underneath the bottom bracket shell.

(A) Junction B fixing bolt
(10.5 mm or 15 mm)

Tightening torque



1.5 - 2 N·m



Click here for the latest Dealer's Manual

<https://si.shimano.com/DM/AL0001>

6

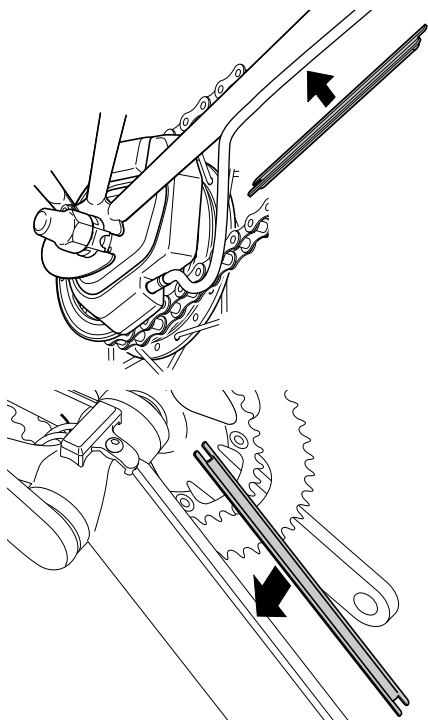

Next, install the electric wire cover onto the frame.

In order to make sure that the electric wire cover is securely installed, clean the frame with alcohol or some other cleaning agent to remove any grease or other substances before installing the cover.

Place the electric wire cover over the electric wires, and then attach it to the frame.

7

After connecting the electric wires to all of the components, install the battery and check the operation.

Check that gear-shifting of the rear can be performed properly by operating the shifting switch.



Disconnection of the electric wires

NOTICE

Do not keep connecting and disconnecting the small waterproof connector. The waterproof section or the connecting section may become worn or deformed, and the function may be affected.

1

MU-UR500/MU-S705

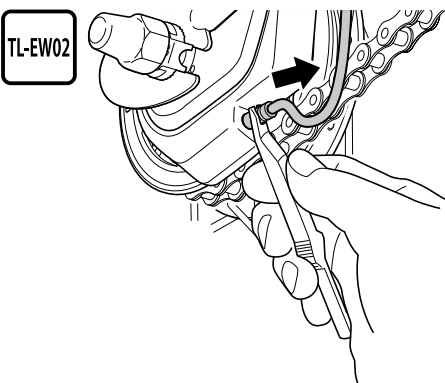

Use the wide end of the TL-EW02 Shimano original tool to disconnect the electric wires.

NOTICE

Use the wide end of the TL-EW02 Shimano original tool to disconnect the electric wires. If you pull too firmly, problems with operation may occur. Insert so that the flat side is facing toward the motor unit, and then tilt it so as to push out the connector of the electric wire.

When disconnecting the electric wire from a lever, face the flat side toward the lever.

When disconnecting the connector of junction, insert the Shimano original tool so that the flat side is facing toward junction.

ST-S705

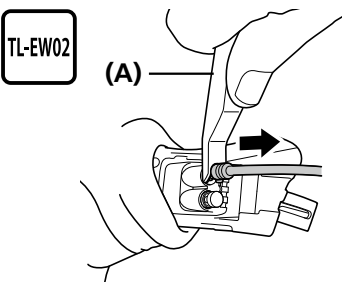

SM-JC41

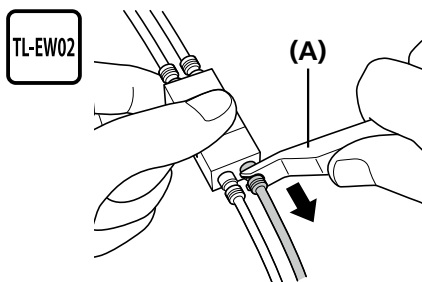

SM-JC40

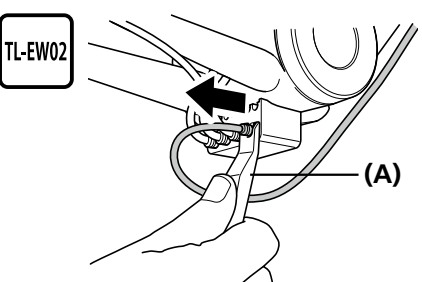

SC-S705

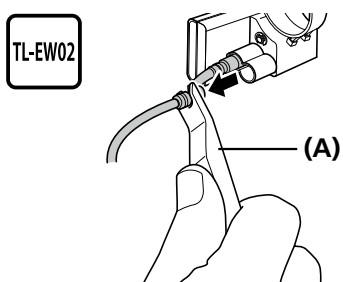

(A) TL-EW02

3 Run any excess length of electric wire along the handlebar, and use zip tie or similar to secure the electric wire to the handlebar.



Click here for the latest Dealer's Manual

<https://si.shimano.com/DM/AL0001>

Built-in battery mount type (SM-JC41)

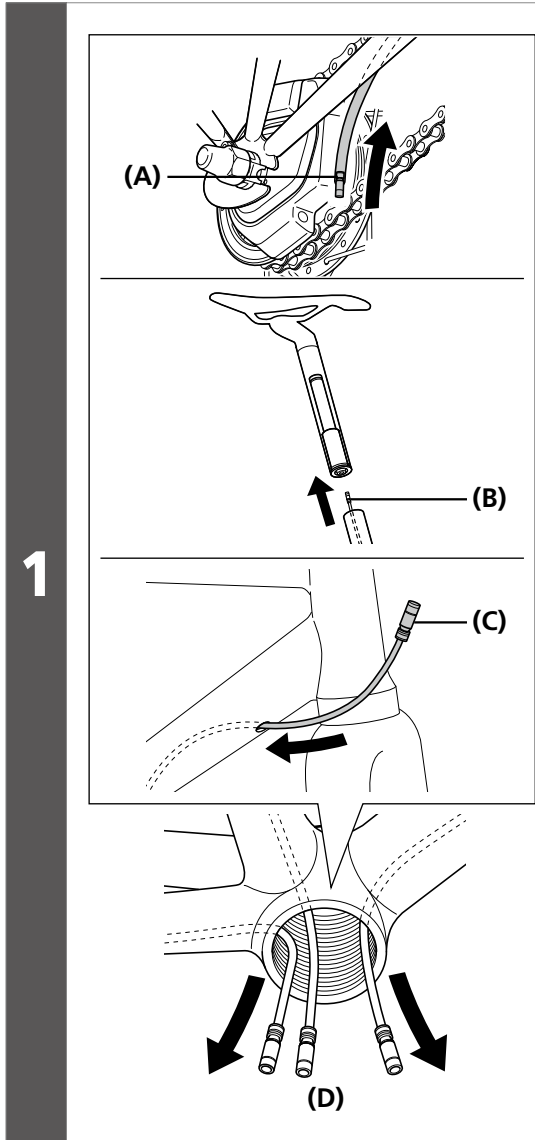

First, insert the electric wire for each of SC-S705, the battery mount, and the motor unit through the hole in the frame to the hanger section.

- (A) Electric wire for motor unit
- (B) Electric wire for built-in battery
- (C) Electric wire for SC-S705
- (D) Bottom bracket shell

NOTICE

The electric wires have a correct way of being inserted.
Make sure that you insert them from the direction shown in the illustration.

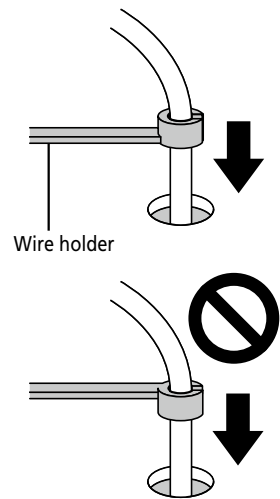

2

TL-EW02

Connect each electric wire to junction B.

(z) Insert a dummy plug in the unused E-TUBE ports. (A dummy plug is included with MU-UR500/MU-S705.)

(A)

(A) TL-EW02

NOTICE

Be sure to push them together until they connect with a click.

3

Connect the electric wires to SC-S705, the motor unit and the battery mount.

SC-S705

TL-EW02

(A)

Battery mount

TL-EW02

(A)

Motor unit

TL-EW02

(A)

(A) TL-EW02



MAINTENANCE

Adjusting the motor unit (connection and communication with PC)

CAUTION

- Improper adjustment may cause gear engagement skipping, resulting in an accidental fall.
- Perform adjustment only when you have an unusual feel during shifting. If there is no problem with shifting, unnecessary adjustment may worsen shifting performance.

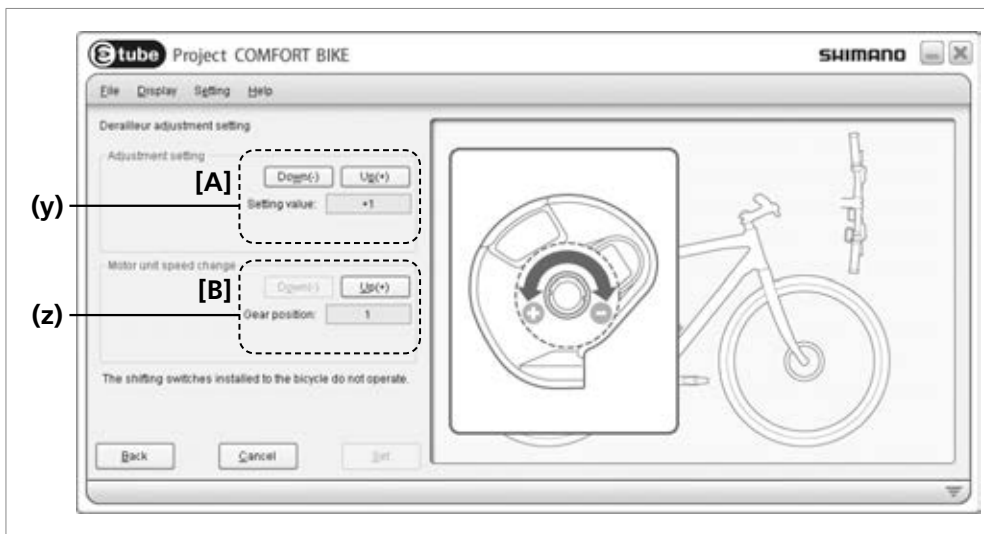

(y) Set the adjustment value

(z) Shift gears



This screen is shown in English, however, a total of 8 languages are available on E-TUBE PROJECT.
(Japanese/English/German/French/Italian/Chinese/Dutch/Spanish)

1 Download the latest version of E-TUBE PROJECT from the support website.
(<http://e-tubeproject.shimano.com>)

2 Connect SM-PCE1 or SM-BCR2.
Connect the battery when connecting SM-BCR2.

3 Activate the adjustment setting mode in E-TUBE PROJECT.

Check that the adjustment value is set to 0 (default) in E-TUBE PROJECT [A].

4	(1)	Value is set to 0	⇒ Go to step 5				
	(2)	Value is set to other than 0	Adjust the value to 0 and shift gears to check whether abnormal noise or unusual feels have been eliminated. At this time, shift gears via E-TUBE PROJECT [B].	<table border="1"> <tr> <td>The problem persists</td> <td>⇒ Go to step 5</td> </tr> <tr> <td>The problem has been remedied</td> <td>⇒ Go to step 6</td> </tr> </table>	The problem persists	⇒ Go to step 5	The problem has been remedied
The problem persists	⇒ Go to step 5						
The problem has been remedied	⇒ Go to step 6						



Click here for the latest Dealer's Manual

<https://si.shimano.com/DM/AL0001>

Change the adjustment value by one in the + or - direction in E-TUBE PROJECT (Illustration [A] below), and check the sound or feel of gear shifting.

* Adjustment can be performed 4 increments in the + direction and 4 decrements in the - direction; a total adjustment range of 8 values.

At this time, shift gears via E-TUBE PROJECT [B].

5

(1)	The problem has been remedied	Check the sound or feel of gear shifting again while changing the adjustment value one by one in the same direction. Continue adjusting the value until the abnormal noise or unusual feels are eliminated.		
(2)	No sign of improvement	Change the adjustment value by one again in the same direction and then check the sound or feel of gear shifting again.	The problem has been remedied	⇒ Go to step 5(1)
			The problem persists	⇒ Go to step 5(3)
(3)	The condition has worsened	Change the adjustment value by two in the opposite direction and then check the sound or feel of gear shifting again. Continue adjusting the value by one in the same direction until the abnormal noise or unusual feels are eliminated.		

6

Finally, ride the bicycle to check whether there is no problem.



Click here for the latest Dealer's Manual

<https://si.shimano.com/DM/AL0001>

Adjusting the motor unit (connection and communication with smartphone or tablet)

CAUTION

- Improper adjustment may cause gear engagement skipping, resulting in an accidental fall.
- Perform adjustment only when you have an unusual feel during shifting. If there is no problem with shifting, unnecessary adjustment may worsen shifting performance.

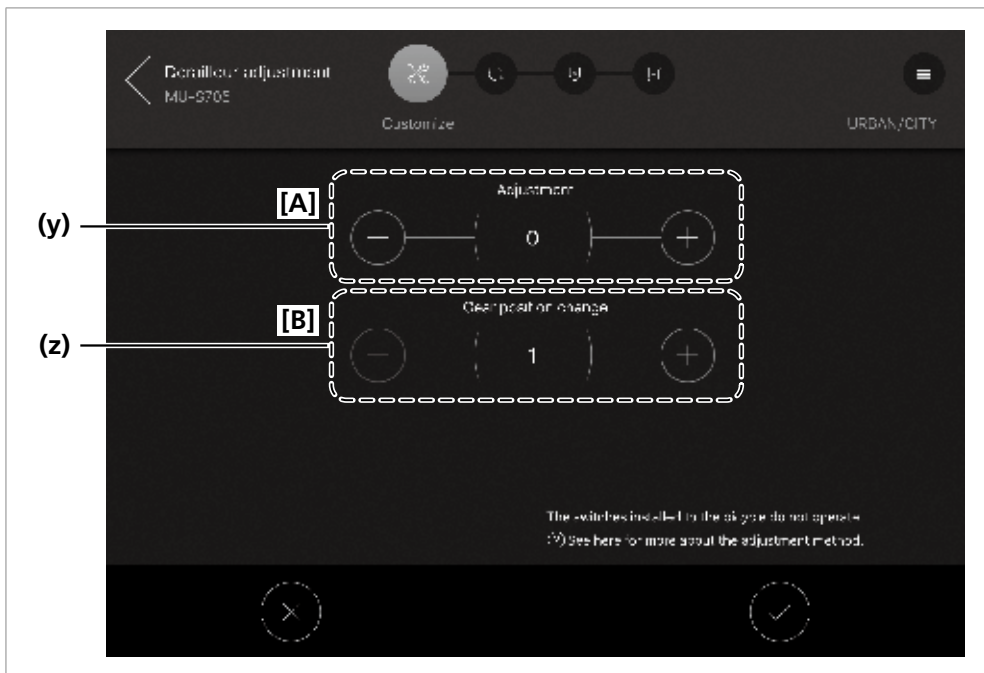

- (y) Set the adjustment value
- (z) Shift gears

TECH TIPS

This screen is shown in English, however, a total of 8 languages are available on E-TUBE PROJECT.
(Japanese/English/German/French/Italian/Chinese/Dutch/Spanish)

1 Download E-TUBE PROJECT for smartphones/tablets.

2 Establish a Bluetooth LE connection with a smartphone or tablet referring to the section "About wireless functions (SC-MT800)".

3 Activate the adjustment setting mode in E-TUBE PROJECT.

Check that the adjustment value is set to 0 (default) in E-TUBE PROJECT [A].

4

(1)	Value is set to 0	⇒ Go to step 5		
(2)	Value is set to other than 0	Adjust the value to 0 and shift gears to check whether abnormal noise or unusual feels have been eliminated. At this time, shift gears via E-TUBE PROJECT [B].	The problem persists	⇒ Go to step 5
			The problem has been remedied	⇒ Go to step 6



Click here for the latest Dealer's Manual

<https://si.shimano.com/DM/AL0001>

Change the adjustment value by one in the + or - direction in E-TUBE PROJECT (Illustration [A] below), and check the sound or feel of gear shifting.

* Adjustment can be performed 4 increments in the + direction and 4 decrements in the - direction; a total adjustment range of 8 values.

At this time, shift gears via E-TUBE PROJECT [B].

5

(1)	The problem has been remedied	Check the sound or feel of gear shifting again while changing the adjustment value one by one in the same direction. Continue adjusting the value until the abnormal noise or unusual feels are eliminated.		
(2)	No sign of improvement	Change the adjustment value by one again in the same direction and then check the sound or feel of gear shifting again.	The problem has been remedied	⇒ Go to step 5(1)
			The problem persists	⇒ Go to step 5(3)
(3)	The condition has worsened	Change the adjustment value by two in the opposite direction and then check the sound or feel of gear shifting again. Continue adjusting the value by one in the same direction until the abnormal noise or unusual feels are eliminated.		

6

Finally, ride the bicycle to check whether there is no problem.



Click here for the latest Dealer's Manual

<https://si.shimano.com/DM/AL0001>

In the case of 8-speed internal geared hub (oil maintenance kit: Y00298010)



(A)

To maintain the product in good working order, it is recommended to have a bicycle dealer or nearest agency carry out maintenance such as lubrication of the internal parts about once every two years from the first time of use (once about every 5,000 km if the bicycle is used very frequently).

Also, for carrying out maintenance, the use of Shimano internal geared hub grease or a lubrication kit is recommended.

If Shimano grease or a Shimano lubrication kit is not used, problems such as a malfunction in gear shifting may occur.

(A) WB maintenance oil set (Y00298010)

1



Fill the container with maintenance oil to a height of 95 mm.

(z) 95 mm

2



Immerse the internal unit in the oil from the left side until the oil reaches up to ring gear unit 1, as shown in the illustration.

(z) Ring gear unit 1

3



Keep the internal unit immersed for approximately 90 seconds.



4



Remove the internal unit from the oil.

5



Let excess oil drain off for approximately 60 seconds.

6



Reassemble the hub.



■ In the case of 11-speed internal geared hub (Oil maintenance kit: Y13098023)

Tools included in the kit: Syringe, Tube, Bleed nipple, O ring, Container

General Safety Information

WARNING

- When changing the oil, be careful that no oil gets on the disc brake rotor, brake pads, on the rim when using rim brakes, etc. If oil gets on any of these parts, there is a danger that brake performance may be reduced. Take care of this problem according to the procedures in the brake instruction manual.
- Since there is a risk of explosion or fire, do not smoke, eat, or drink while using this oil. In addition, keep it away from ignition sources such as heat, sparks, open flames, or high temperatures and prevent it from catching fire due to static electricity sparks or other sparks.
- Use only outdoors or in a well-ventilated area. Inhalation of oil mist or vapors may cause nausea. Be careful to provide ventilation and use a respirator-type mask. If mist or vapor is inhaled by mistake, go immediately to an area with fresh air, stay warm and quiet, and seek professional medical advice if required. If breathing stops, perform artificial respiration, and if breathing is difficult, provide the affected person with oxygen.

Cautions regarding handling of SG-S700 OIL :

- Contact with eyes may result in irritation. Use safety glasses when handling, and avoid contact with eyes. In the event of eye contact, flush with fresh water and seek medical assistance immediately.
- Contact with skin may cause a rash and discomfort. Use gloves when handling. In the event of skin contact, wash well with soap and water. If skin condition becomes abnormal, seek medical assistance immediately.
- Do not drink. If it is drunk by mistake, do not induce vomiting; make the affected person drink 1 to 2 cups of water and seek medical assistance immediately. If the affected person loses consciousness, do not give the person anything by their mouth. If vomiting occurs naturally, tilt the body to prevent inhalation.
- After use, be sure to wash hands thoroughly.
- When storing, close the container tightly to prevent water or foreign materials from entering; store out of reach of children; do not store in areas subject to direct sunlight, areas subject to temperatures above 40°C, areas subject to water or high humidity where rust is likely to occur, or in areas where there is a risk of freezing.
- Dispose of used oil, old oil, or oil used for cleaning in accordance with applicable local laws and regulations.
- To maintain product performance, oil should be changed after the first 1,000 km from start of use of the product, and once every 2 years thereafter (after every 5,000 km if bicycle is ridden frequently).
- When performing maintenance, use only Shimano SG-S700 OIL. If SG-S700 OIL is not used, problems such as an oil leakage and gear shifting malfunction may occur.
- When using a 1L can of oil, it may become impossible to suck out oil with a syringe when there is only a little oil left. First, transfer all oil to a different container.
- Read these instructions carefully, and keep them in a safe place for later reference.



Internal geared hub: Oil replacement

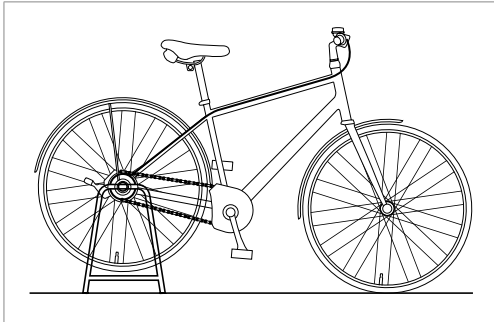

Using a stand, etc., enable the rear wheel to turn while performing work.

Draining out the old oil

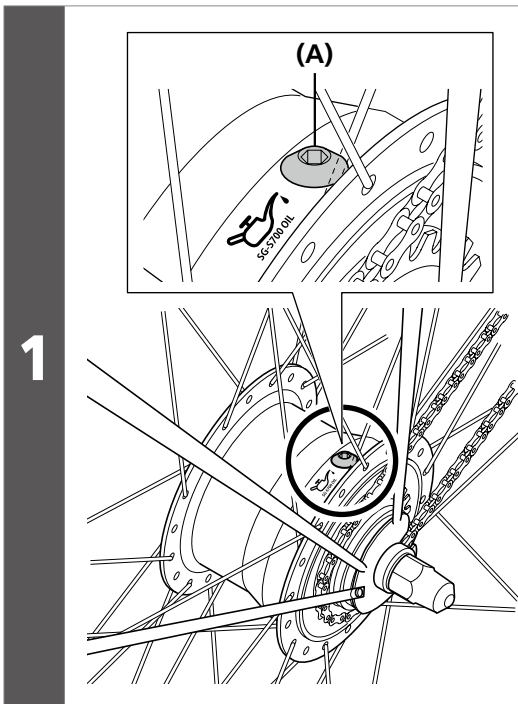

Rotate the wheel slowly until the oil port is facing up.

(A) Oil port

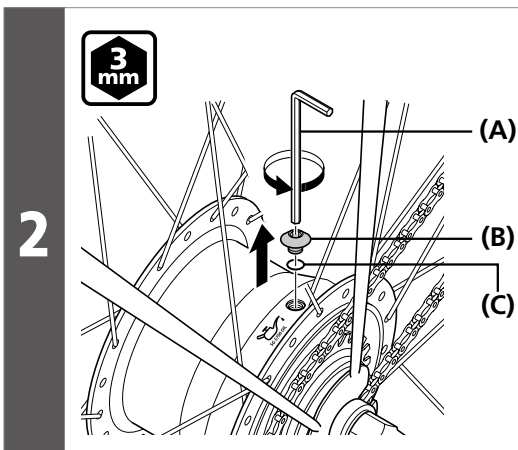

Remove the oil port bolt and O-ring.

(A) 3 mm hexagon wrench
(B) Oil port bolt
(C) O-ring

NOTICE

Be careful that the oil port is facing up; if the oil port bolt is loosened when it is not facing up, the oil inside may leak out.



Click here for the latest Dealer's Manual

<https://si.shimano.com/DM/AL0001>

3

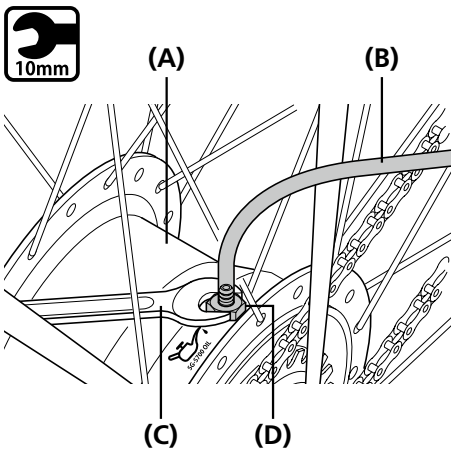

Attach the bleed nipple with tube attached to the hub shell.

- (A) Hub shell
- (B) Tube
- (C) 10 mm spanner
- (D) Bleed nipple

- (A) Hub shell
- (B) Tube
- (C) 10 mm spanner
- (D) Bleed nipple

Tightening torque	
	1 - 3 N·m

 **TECH TIPS**

Check that the O-ring is properly installed on the bleed nipple.

4

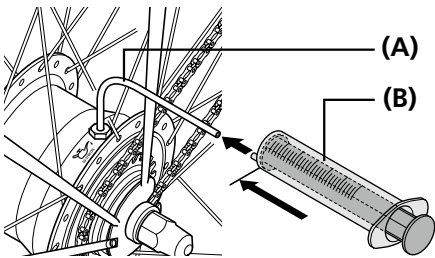

With the piston of the syringe pushed fully in, firmly connect the syringe to the tube.

- (A) Tube
- (B) Syringe

- (A) Tube
- (B) Syringe

5

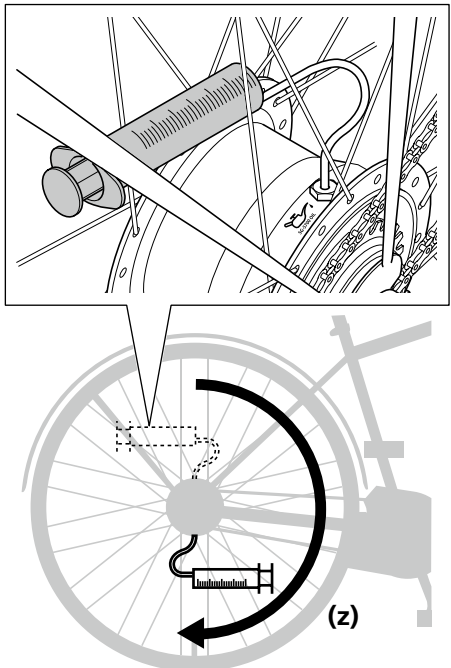

Insert the syringe between the spokes, and slowly turn the wheel forward until the oil port is facing down.

- (z) Turn in forward direction

6 Wait about 5 minutes with the hub kept still and not turning so that the oil settles.



Click here for the latest Dealer's Manual

<https://si.shimano.com/DM/AL0001>

7

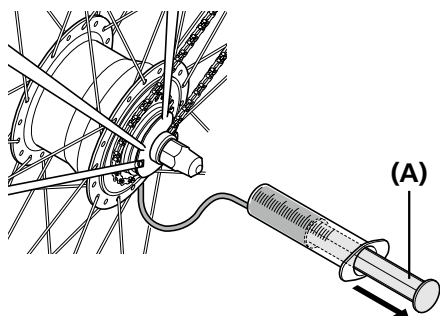

Pull the piston out slowly to draw out the oil inside the hub shell.

(A) Piston

NOTE

If the piston is pulled out quickly, air is likely to be mixed in.

8

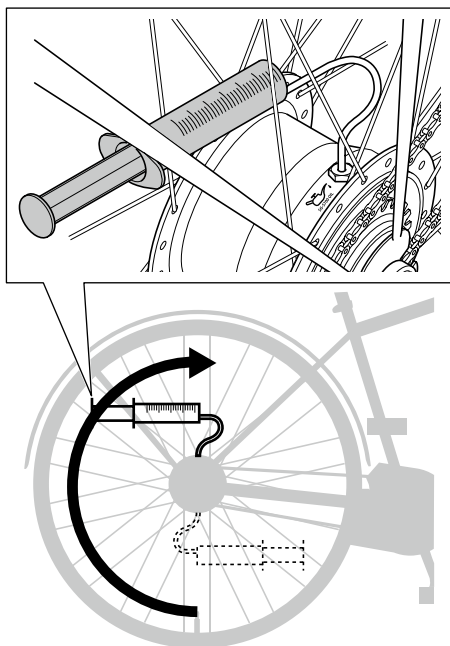

Rotate the wheel slowly until the oil port is facing up.

NOTE

To make sure that the syringe does not get caught by the chain case, etc., store the syringe between the spokes when turning the wheel.

9

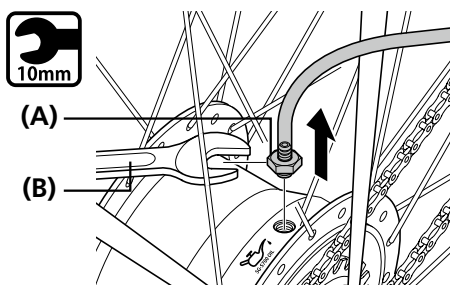

While being careful that the tube does not come off the syringe, remove the bleed nipple.

(A) Bleed nipple
(B) 10 mm spanner

10

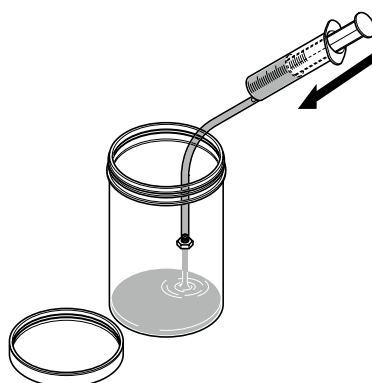

Remove the old oil from the syringe.



Cleaning the inside

1

Attach the bleed nipple to the hub shell.

2

Suck 25 ml of new oil into the syringe and connect it firmly to the tube.

3

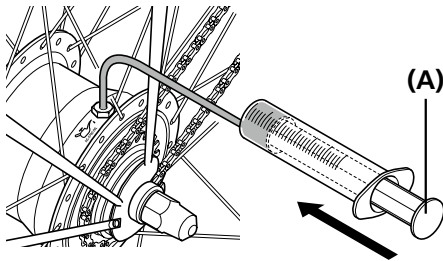

Push the piston to inject the new oil into the inside of the hub.

4

After pulling back the piston to reduce the internal pressure, remove the bleed nipple.

5

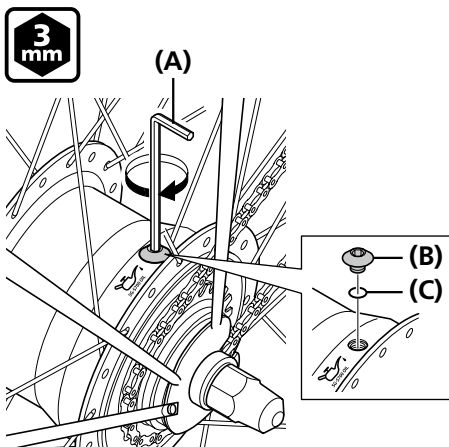

Install the O-ring and the oil port bolt.

Tightening torque



1 - 3 N·m



TECH TIPS

If the syringe or tube becomes dirty when removing old oil or cleaning the inside of the hub, clean the syringe and tube using parts cleaner, etc., if necessary.

(A) Piston



TECH TIPS

When the oil is forced in, the internal pressure will increase and the piston may push back. If the piston is periodically pulled back to reduce the pressure inside the hub, the oil will be easier to inject into the inside of the hub.



TECH TIPS

If the bleed nipple is removed without pulling back the piston, the oil may flow back into the piston together with air from inside the tube and spill out of the piston.

(A) 3 mm hexagon wrench

(B) Oil port bolt

(C) O-ring

Tightening torque



2 - 3 N·m



Click here for the latest Dealer's Manual

<https://si.shimano.com/DM/AL0001>

6 While performing gear-change operations, turn the pedals to turn the wheel for about 1 minute.

7 Keep the wheel still without rotating for about 1 minute.

8 Remove the oil from inside by following the procedures in **Draining out the old oil** above.

Injecting new oil

1 Inject 25 ml of new oil into the hub by following steps **Cleaning the inside 1 - 5** above.

2 Clean off any oil that may have gotten on the hub, etc.



■ Oil maintenance of the internal assembly

The work performed here will be the same as in SG-C6001/SG-6011.

Refer to "Oil maintenance of the internal assembly" (P.34).



▶ Click here for the latest Dealer's Manual

<https://si.shimano.com/DM/AL0001>

Troubleshooting

Troubleshooting

Check the following prior to performing adjustment or maintenance.

- All of the following occurrences are due to the internal gear-shifting structure and are not the failure of the internal components.

Phenomenon	Type of hub		Gear positions where phenomenon might occur
	For coaster brakes	For roller brakes/ V-BRAKE	
Noise occurs when the pedals rotate.	X	-	All gear positions except 1st
Noise occurs when the bicycle is pushed backward.	X	X	All gear positions except 1st
The hub has a built-in mechanism that supports gear shifting* and when the mechanism operates during gear shifting, noise and vibrations occur.	X	X	All gear positions
Depending on gear position, gear-shifting may feel different.	X	X	All gear positions
Noise occurs when pedal rotation is stopped during riding.	X	-	All gear positions

*Gear Change Support

SHIMANO gear change support mechanism utilizes some portion of pedaling force at down shifting. The result is a quick and precise downshift with very light feeling on both mechanical and DI2 version of the hub.

40% less shifting force required

Pedaling force is applied against the sleeve to help overcome sleeve return pressure and execute the shift.

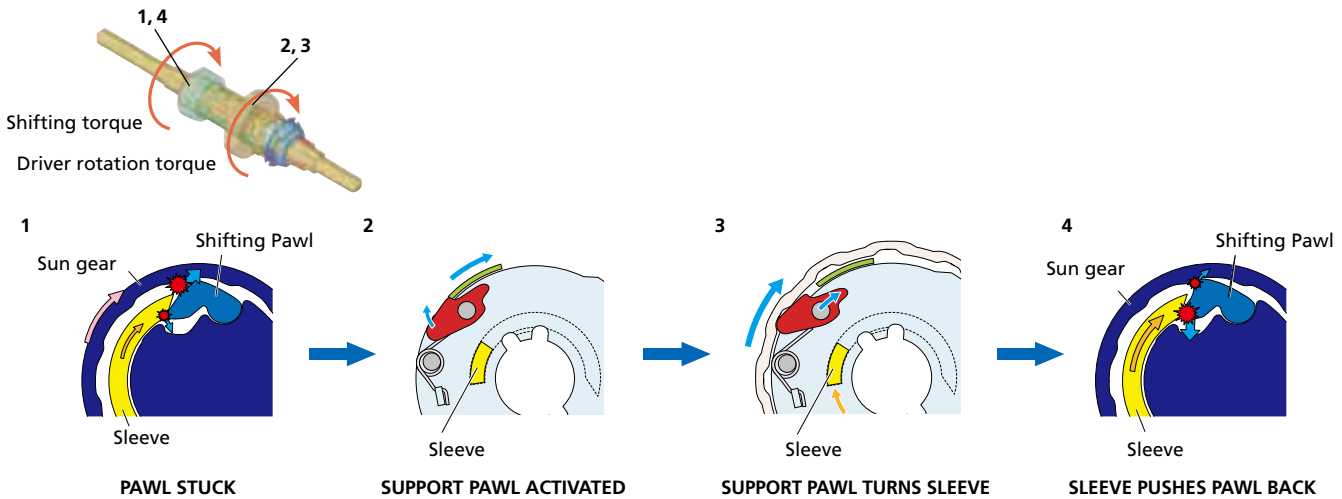

NOTICE

- If you cannot determine a definite cause for the malfunction, it is recommended to replace the internal assembly. (Refer to p.71)

Troubleshooting

		Symptom/cause		Solution	Reference page	
Gear shifting	Gear shifting is poor.	The cable has been routed inappropriately.		Check for any areas where the curvature of the cable is too tight. When using a SHIMANO genuine outer casing, the recommended minimum curvature is R30 mm.	-	
		Cable performance is poor.		Using a SHIMANO genuine cable/outer casing may improve this.	-	
		The cassette joint was adjusted while over-shifted.		For INTER-8 : Set the gear to 4th from 1st. For ALFINE-8 : Set the gear to 4th from 8th. Adjust the cassette joint again. To avoid over-shifting the shifting lever, change the setting gradually and with minimal force.	P.26	
	Gear shifting is impossible.	The cable was not adjusted properly.		Turn the cable adjustment barrel on the REVOSHIFT lever and align the bracket on the cassette joint with the setting line on the pulley.	P.26	
		Check whether gear shifting is possible with the wheel removed from the frame.	Possible	The wheel was not installed properly to the frame.	Recheck the procedure for installing the hub to the frame.	P.9, P.42
			Not possible	There is a malfunction in the shifting lever.	Replace the lever with a new one.	P.15
There is a malfunction in the hub.		If something is broken inside, replace the broken part or unit. If nothing is broken or if you are unsure, replace the internal assembly.		P.71		
Abnormal noise	There is an abnormal noise.	The cable was not adjusted properly.		For INTER-8 : Set the gear to 4th from 1st. For ALFINE-8 : Set the gear to 4th from 8th. Turn the cable adjustment barrel on the REVOSHIFT lever and align the bracket on the cassette joint with the setting line on the pulley.	P.26	
	The abnormal noise does not stop even after adjusting the cable.	During gear shifting.		Replace the internal assembly.	P.71	
		When pedaling.		If something is broken inside, replace the broken part or unit. If nothing is broken or if you are unsure, replace the internal assembly.	P.71	
When riding	The display on the indicator on the lever differs from the gear position of the hub.	The cable was not adjusted properly.		For INTER-8 : Set the gear to 4th from 1st. For ALFINE-8 : Set the gear to 4th from 8th. Turn the cable adjustment barrel on the REVOSHIFT lever and align the bracket on the cassette joint with the setting line on the pulley.	P.26	
		Internal unit failure.		If something is broken inside, replace the broken part or unit. If nothing is broken or if you are unsure, replace the entire internal unit.	P.71	
	The hub is difficult to rotate, or does not rotate smoothly.	The cone is too tight.		Adjust the stop nut so that the hub shell can be turned smoothly without any gap. After adjusting, secure the stop nut with the locknut.	P.89	
		Internal unit failure.		If something is broken inside, replace the broken part or unit. If nothing is broken or if you are unsure, replace the entire internal unit.	P.71	
	There is rattling when pedaling.	The area around the cone is damaged.		Replace the right hand cone and driver unit.	P.78	
When not riding	Free rotation is not smooth while not pedaling.		Replace the shell, ball retainer and driver unit.	P.72, P.74, P.78		

Troubleshooting

The following items are for coaster brake models.

	Symptoms	Solution	Reference page
Brakes	The brakes are too sensitive.	Apply grease or replace the brake shoe unit	P.73
	The brakes are weak.	Replace the brake shoe unit. If this does not resolve the issue, replace the internal assembly.	P.71, P.73
	The pedal rotation angle is too large until the brakes are applied.	Replace the brake shoe unit. If this does not resolve the issue, replace the internal assembly.	P.71, P.73
	The wheels lock when the bicycle is pushed backward.	If something is broken inside, replace the broken part or unit. If nothing is broken or if you are unsure, replace the internal assembly.	P.71
	Applying the brakes causes an abnormal noise.	Apply grease or replace the brake shoe unit.	P.73
	Rotation feels heavy during free rotation.	Replace the brake shoe unit.	P.73

Disassembly & Assembly

Required Tools

A: Hammer

B: TL-8S11

C: TL-8S20

D: TL-8S30

E: TL-HS42 Hub spanner 22 mm

F: TL-HS37 Hub spanner 17 mm

G: Slotted Screwdriver

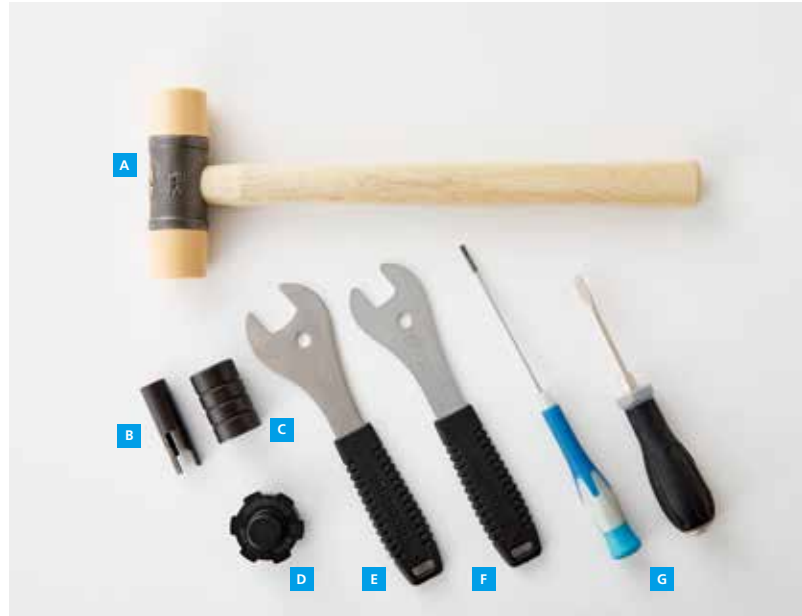

Replacing the Internal Assembly

Refer to the part breakdown (p.102 to 114) for the names of parts.

- 1. Hold the two beveled surfaces of the hub axle on the brake arm side in a vise and remove the dust cap.**



NOTICE

- Forcibly pulling it may cause damage to the bracket cover because of its material properties.
- Do not damage the threads of the hub axle.

- 2. Turn the hub upside down and hold the two beveled surfaces of the hub axle on the sprocket side in a vise.**

- (1) Secure the hub back into place with the drive side downward.
(2) Use TL-HS37 and TL-HS42 to remove the nut.



Locknut 17mm



Stop Nut 22mm

NOTICE

- Do not damage the threads of the hub axle.

- 3. Remove the brake arm unit and ball retainer B from the hub axle.**



Replacing the Internal Assembly

4. Remove the hub shell.



5. The internal assembly can be replaced.



Disassembling the Internal Assembly

Installing the cassette joint

With the brake arm facing downward, pinch the flat portion of the axle with a vise, and secure the internal assembly in place.

1. Remove the brake shoe unit.



2. Remove the O-ring.



3. Carefully remove the stop ring with a slotted screwdriver.

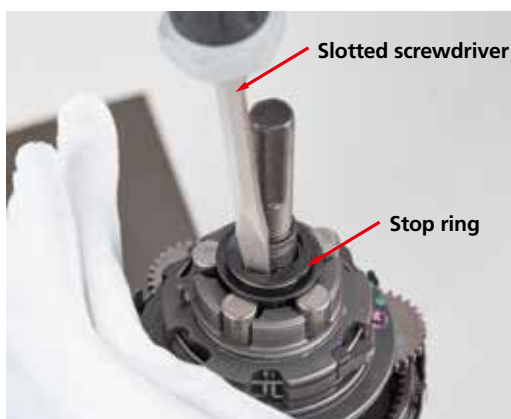

NOTICE

- The Stop ring detaches with some force, so be careful not to lose it
- Do not reuse a Stop ring that has been removed.

Disassembling the Internal Assembly

- 4. Remove carrier unit and ring gear by lifting straight up. Do not rotate to disengage.**

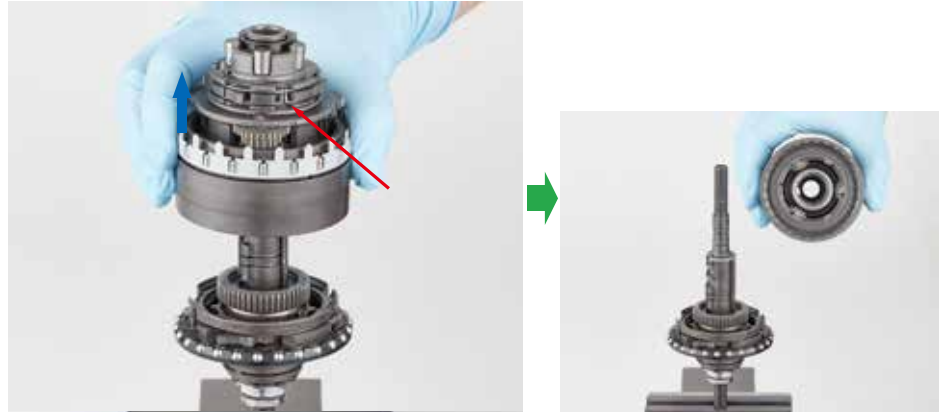

- 5. Remove the ring gear 1 stop spring with a slotted screwdriver.**



- 6. Remove ball retainer O while pushing down the pawls B on the driver unit with a slotted screwdriver or other tool.**

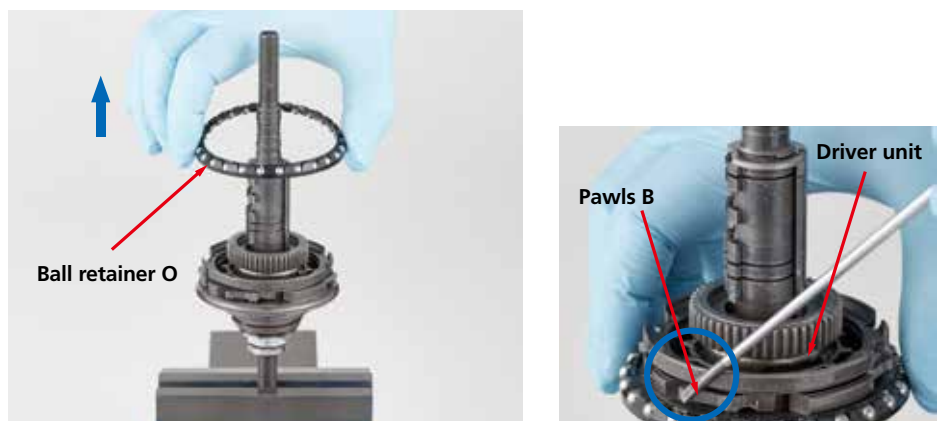

Disassembling the Internal Assembly

7. Reverse axle unit in vice to access the drive side cone assembly.



8. Remove the right-hand lock nut.



NOTICE

- The E-ring detaches with some force, so be careful not to lose it.
- Do not reuse an E-ring that has been removed.

9. Remove the stop washer.



Disassembling the Internal Assembly

10. Remove the lock washer.



11. Remove the driver plate.



12. Remove the hub axle.

- (1) Place the driver assembly on the vise.
- (2) Set TL-8511 into the groove such that the right hand sleeve is contacting the notch in the tool.

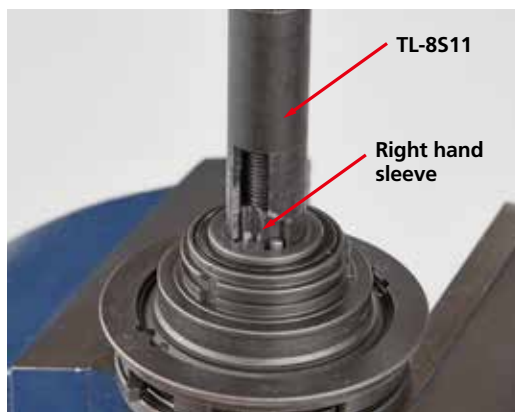

NOTICE

- Place the driver assembly and vise so that they are in the correct position. Otherwise, the part may detach or be damaged, making it impossible to reinstall it.

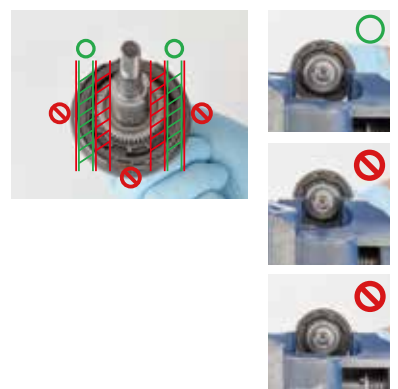

Disassembling the Internal Assembly

- (3) Use a hammer to strike TL-8511.
- Use your hand to support the hub axle while you strike it.



13. Remove the right hand cone.



14. Remove the ball retainer P.



Disassembling the Internal Assembly

15. Remove the driver unit.



16. Remove the return spring A.



17. Remove the clutch unit by turning it counterclockwise and aligning the two teeth to the two grooves, as shown.



Disassembling the Internal Assembly

This completes the disassembly of the INTER-8 coaster hub.



Assembling the Internal Assembly

1. With the hub axle unit mounted in a vice, align the two teeth on the clutch unit with the two notches in the hub axle unit. Turn the clutch unit clockwise until it is in its final position as shown.

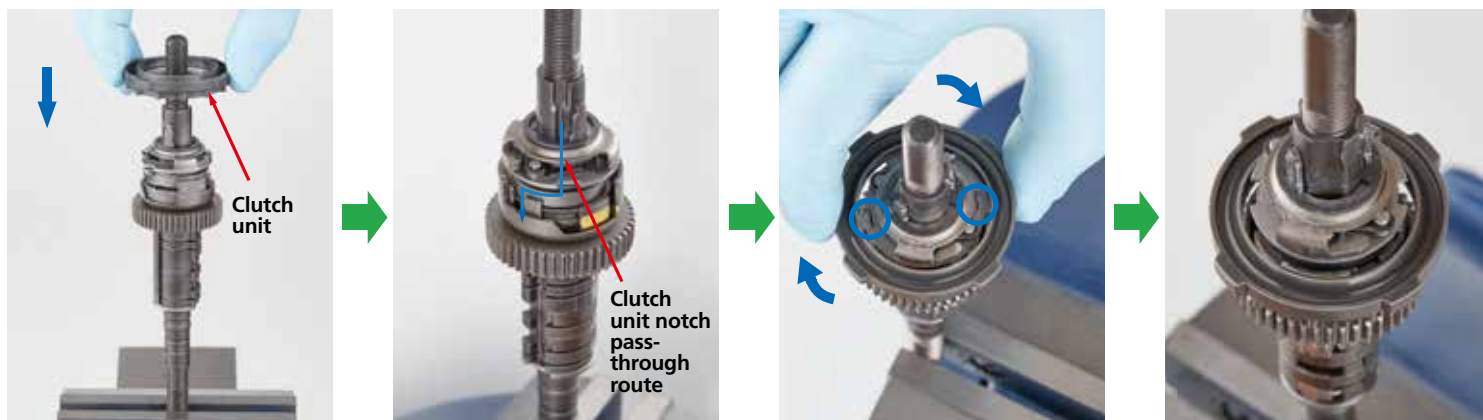

NOTICE

- During the assembly procedures coat all seals, gears and pawl assemblies with a thin coat of Nexus specific grease. Where indicated by blue grease icon, apply grease liberally.



(Y-041020800)



2. Install the return spring A with the largest coil downward. The spring should sit in the groove on the clutch unit. Be careful not to install the return spring A upside down.

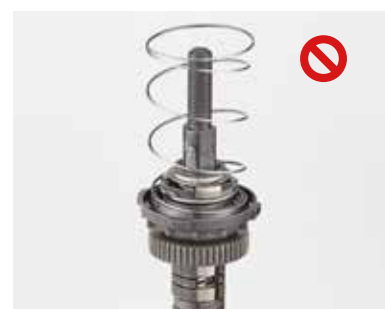
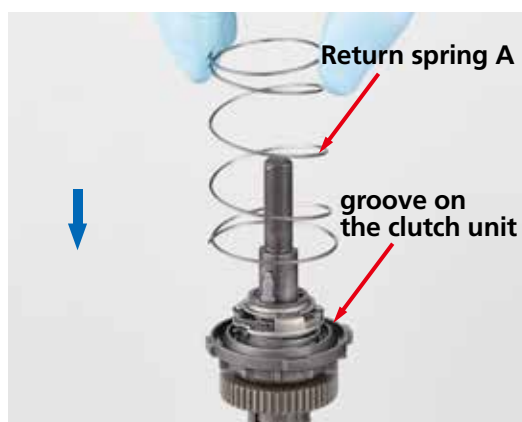

Assembling the Internal Assembly

3. Assemble the driver unit by aligning the more shallow notch on the driver unit with the wider tooth on the clutch unit. Rotate the driver counterclockwise to hold the compressed spring in position.

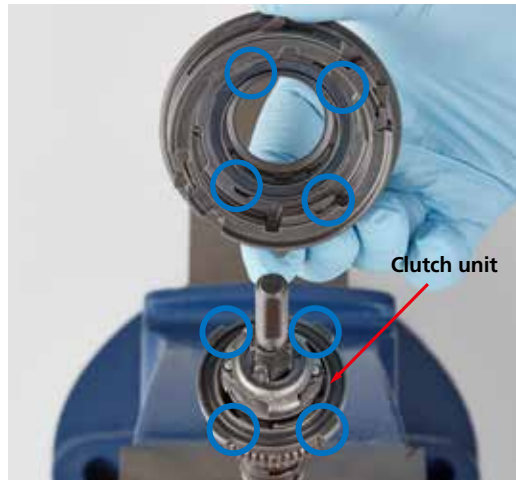

NOTICE

- Assemble the driver unit while pushing pawls B as shown in the picture.



4. Install the ball retainer P.



Assembling the Internal Assembly

5. When installing the right hand cone, align the two serrations with the grooves in the axle, as shown.

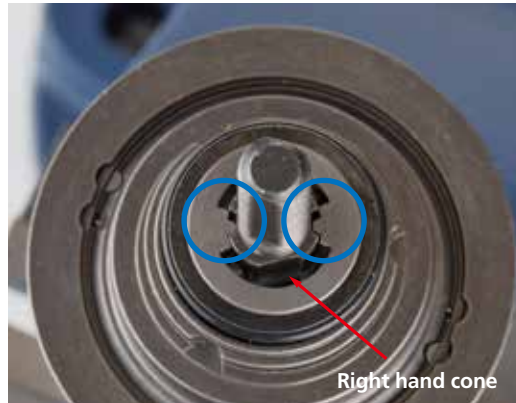

6. Set the cone installation tool (TL-8520) and strike it until it comes to a stop.



NOTICE

- Make sure the right hand cone is completely seated, as shown and the seal is installed equally.

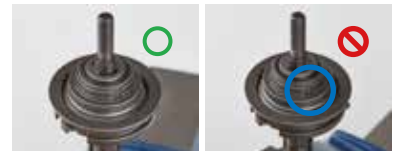

7. Install the driver plate. Be careful of the setting direction as shown in the picture.

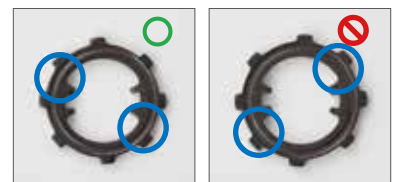

Assembling the Internal Assembly

8. Install the lock washer.



9. When installing the stop washer, align the two teeth with the two grooves of the lock washer.



10. Tighten the right-hand lock nut.



NOTICE

- If either the lock washer or driverplate rotates during this step, return to assembly step 5 and make sure that the cone is correctly seated.

Assembling the Internal Assembly

11. Reverse the axle unit in the vice to complete assembly.



12. Install the ball retainer O while pushing pawls B one by one. Be careful not to displace pawls B on the driver unit.



Assembling the Internal Assembly

13. How to align the three planetary gears and install the ring gear.

(Without any tools)

Align the three marks, which are on the planetary gears, as shown in the picture. Now you can install the ring gear.



(With tool)

Align the grooves of the tool with the marks on the planetary gears. The purpose of the tool is to fix the planetary gear's position. Now you can install the ring gear.



14. Install the ring gear 1 stop spring with a slotted screwdriver.



Assembling the Internal Assembly

15. Align the internal tooth on the ring gear and carrier unit with the groove in the hub axle unit. Install ring gear and carrier unit slowly.



NOTICE

- Be careful to fit A to A of the driver unit and the hub axle unit as shown in the picture.

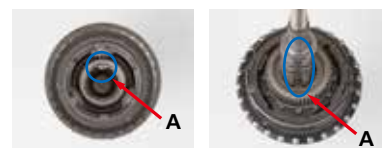

To set all four pawls in the correct position. Use a flat blade screwdriver to depress pawls, as shown, during assembly. Turn unit and check that all pawls are in the proper position.

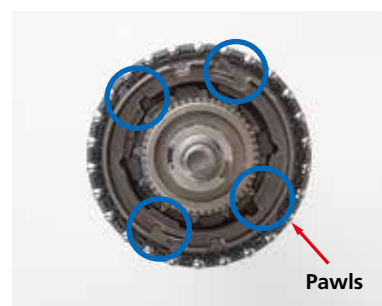

Assembling the Internal Assembly

16. Install the stop ring.



NOTICE

- If there is no visible groove to receive the stop ring, it is likely that the ring gear and carrier unit are not properly assembled, return to assembly step 15.

17. Install the O-ring.



18. Install the brake shoe unit.

(Install so that the end of the slide spring on the hub fits into the gap in the brake shoe.)



NOTICE

- Keep the vertical direction of the brake shoe unit in mind as you install it.

Upper side

Lower side



Assembling the Internal Assembly

19. Install the hub shell.

Be careful that the slide spring inside the hub shell does not touch the convex section of the internal assembly.



20. Place ball retainer onto the hub shell.

(1) Insert the larger of the two hooks on either end of the spring into the hole in ring gear¹.



NOTICE

- Be careful of the setting direction.



21. Place the brake arm unit onto the hub axle and turn it to the left and right so that the serrations of the brake shoe and brake arm unit engage with each other. Then push the brake arm unit fully into the brake shoe unit.

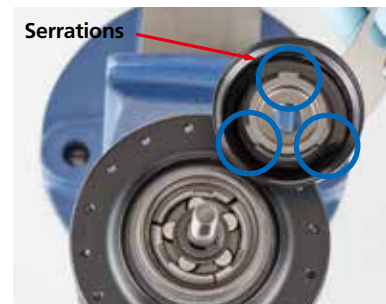

NOTICE

- Apply a liberal coating of internal hub grease to the inside and outside of the brake shoe unit.



(Y-041020800)

Assembling the Internal Assembly

22. Screw the stop nut to adjust so that the hub shell can be turned smoothly without any play. After adjusting, secure the stop nut with the locknut.



23. Turn the unit over, secure it back in the vise, and install the dust cap. Install so that there is a 1 to 1.5 mm gap with the dust cap.

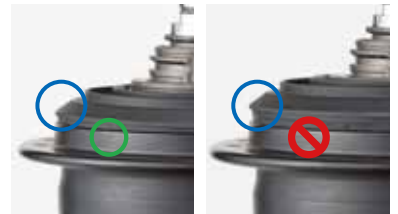

24. Assembly is now complete.



Service Parts & Tools

Service Parts and Tools

Cassette Joint



CJ-8S20



CJ-8S40



CJ-8S20BD
for Belt Drive Spec.

The Belt Drive specifications is designed to not interfere with the belt drive.

CJ-8S20

CJ-8S20BD

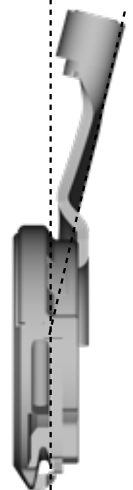

Measurement Tool

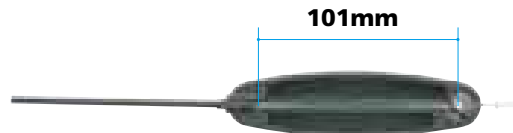

TL-CJ10

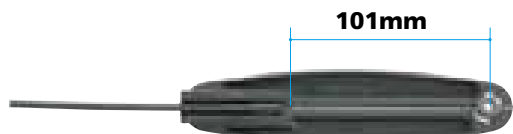

TL-CJ40 (front)

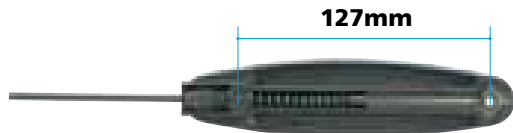

TL-CJ40 (back)



Service Parts and Tools

NEXUS non-turn washers

The shape of the dropout determines which NTW to choose. In the illustration below, you can see the result for various frame dropouts in combination with the chosen NTW.

	5R/L	6R/L	7R/L	8R/L
For right hand side	 5R: Yellow	 6R: Silver	 7R: Black	 8R: Dark blue
For left hand side	 5L: Brown	 6L: White	 7L: Gray	 8L: Dark green

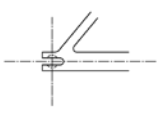
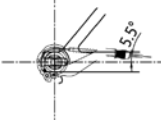
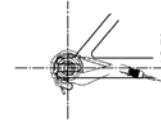
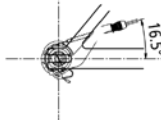
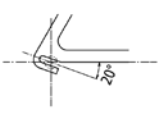
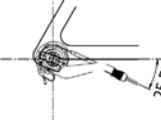
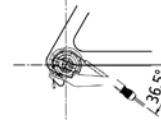
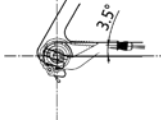
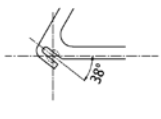
*See Technical Information for the latest information

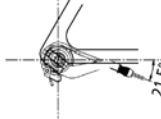
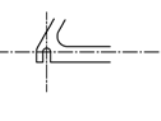
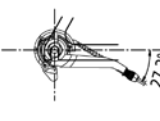
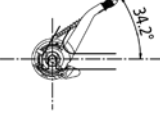
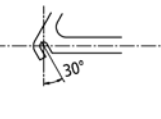
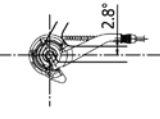
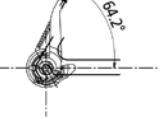
		5R/L	6R/L	7R/L	8R	8L
Reversed type rear dropout					-	-
Standard type rear dropout					-	-
					-	-
Vertical type rear dropout		-	-	-		
		-	-	-		

Service Parts and Tools

	Reversed type rear dropout	Standard type rear dropout	
5R 5L			
6R 6L			
7R 7L			

	Vertical type rear dropout	
8R 8L		

Interchangeability between hubs

Interchangeability

		Compatible Products
Internal Unit	SG-S7051-8	SG-S7051-8 SG-S505
	SG-S7001-8	SG-S7001-8 SG-S7000-8
	SG-C6011-8R/V	SG-C6011-8R/V SG-C6010-8R/V SG-8R35/36
	SG-C6061-8R/V	SG-C6061-8R/V SG-C6060-8R/V SG-8R55/56 SG-8R60
	SG-C6061-8C	SG-C6061-8C SG-C6060-8C SG-8C56
	SG-C6061-8D	SG-C6061-8D SG-C6060-8D
	SG-C6061-8CD	SG-C6061-8CD SG-C6060-8CD
	SG-C6001-8R/V	SG-C6001-8R/V SG-C6000-8R/V SG-8R30/31
	SG-C6001-8C	SG-C6001-8C SG-C6000-8C SG-8C30/31
	SG-C6001-8D	SG-C6001-8D SG-C6000-8D
	SG-C6001-8CD	SG-C6001-8CD SG-C6000-8CD

(NOTE) *The specifications differ depending on the length of the axle etc. Therefore, follow the compatibility of the axle length and such.

Hub dimensions

(Over Locknut Dimensions and Axle)

Hub dimensions (Over Locknut Dimensions and Axle)

SG-C6011-8R / SG-C6011-8V

SG-C6001-8R / SG-C6001-8V / SG-C6001-8C / SG-C6001-8D / SG-C6001-8CD

ALFINE INTER-11, 8 / NEXUS INTER-8, 7, 5E

C-273

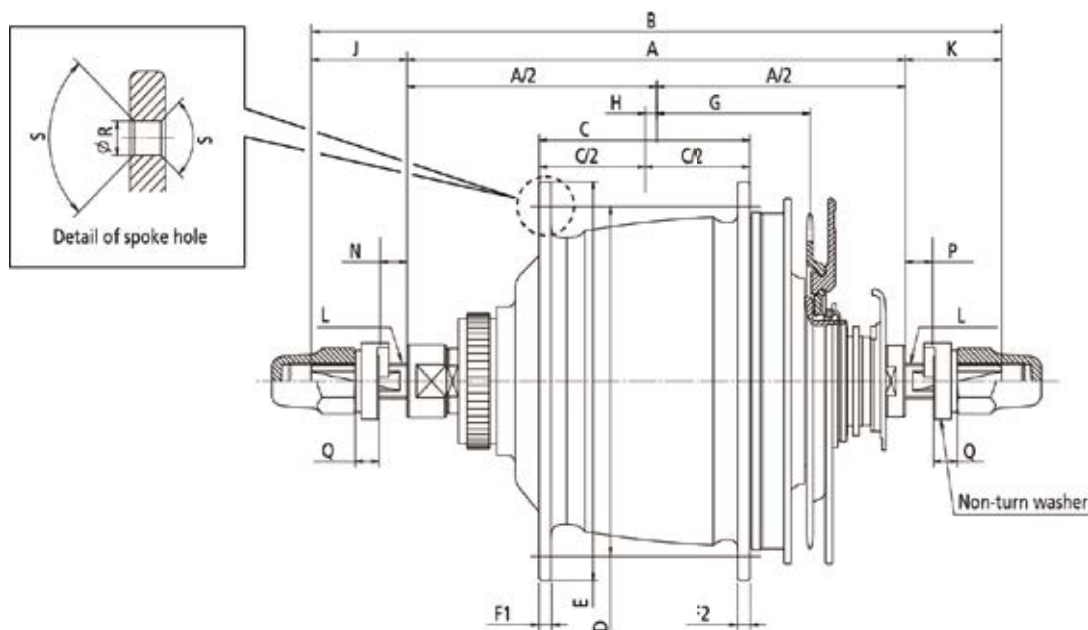

Series	ALFINE		NEXUS			
	INTER-11	INTER-8	INTER-8	INTER-8	INTER-8	INTER-8
Function name	INTER-11	INTER-8	INTER-8	INTER-8	INTER-8	INTER-8
Model No.	SG-S7001-11	SG-S7001-8	SG-C6011-8R SG-C6001-8R SG-C6011-8V SG-C6001-8V	SG-C6001-8C	SG-C6001-8D	SG-C6001-8CD
Speed	11		8			
Gear ratio: Total	409%		307%			
Spoke size	#13 / #14					
A Over locknut dim. / O.L.D. (mm)	135		132	132		135
B Axle length (mm)	187		184			187
C Flange distance (mm)	57.3		58.3		57.3	58.3
D Spoke hole P.C.D. (mm)	92.6					
E Flange diameter (mm)	104.3		105.2			
F	Flange width (mm): F1 (left)					
	Flange width (mm): F2 (right)					
G	Chain line (mm): G1 (outward assembly)					
	Chain line (mm): G2 (inward assembly)					
H	46.8		47.7	47.9		46.8
	41.8		42.7	42.9		41.8
H	3.1		2.7	2.6	3.1	4
J	26			25.7	26	26.6
K			26			25.4
L	Axle size BC3 / 8 TPI 26					
N	5-9		4-9		5-9	4-9
P	5-9		4-9		5-9	4-9
Q	Non-turn washer width 6.4					
R	2.9	2.9	2.9	2.9	2.9	2.9
S	Spoke hole chamfer 90°					

Hub dimensions

SG-C6011-8R / SG-C6011-8V

SG-C6001-8R / SG-C6001-8V / SG-C6001-8C / SG-C6001-8D / SG-C6001-8CD

Series	NEXUS				
	INTER-7		INTER-7	INTER-5E	INTER-5E
Function name	INTER-7		INTER-7	INTER-5E	INTER-5E
Model No.	SG-C3001-7R	SG-C3001-7C	SG-C3001-7D	SG-C7000-5D	SG-C7000-5R SG-C7000-5V SG-C7000-5C
Speed	7			5	
Gear ratio: Total	244%			263%	
Spoke size	#13 / #14				
A Over locknut dim. / O.L.D. (mm)	130		127	135	
B Axle length (mm)	182	201	176	187	
C Flange distance (mm)	54.6	56.2	54.6	57.3	58.3
D Spoke hole P.C.D. (mm)	87	83.5	87	92.6	
E Flange diameter (mm)	99.6	92.5	99.6	105.2	
F	Flange width (mm): F1 (left)	3.2	2.7	3.2	
	Flange width (mm): F2 (right)	3.2	2.3	3.2	
G	Chain line (mm): G1 (outward assembly)	45.3	46.5	46.8	47.2
	Chain line (mm): G2 (inward assembly)	40.3	41.5	41.8	42.2
H	Offset (mm)	3.85	4.6	2.5	3.2 3.7(-5C spec.)
J	Axle length from hub (left)	26	37	24.5	26
K	Axle length from hub (right)	26	34	24	26
L	Axle size	BC3 / 8 TPI 26			
N	Rear dropout mounting width (left, includes stay etc.)	4-9	15-20	4-9	5-9
P	Rear dropout mounting width (right, includes stay etc.)	4-9	12-17	4-9	5-9
Q	Non-turn washer width	6.4			
R	Spoke hole diameter (mm)	2.9	2.7	2.9	
S	Spoke hole chamfer	90°	105°	90°	

Hub dimensions

SG-C6061-8R / SG-C6061-8V / SG-C6061-8C / SG-C6061-8DS / G-C6061-8CD

Internal Geared Hub

C-373

Dimensions C-374

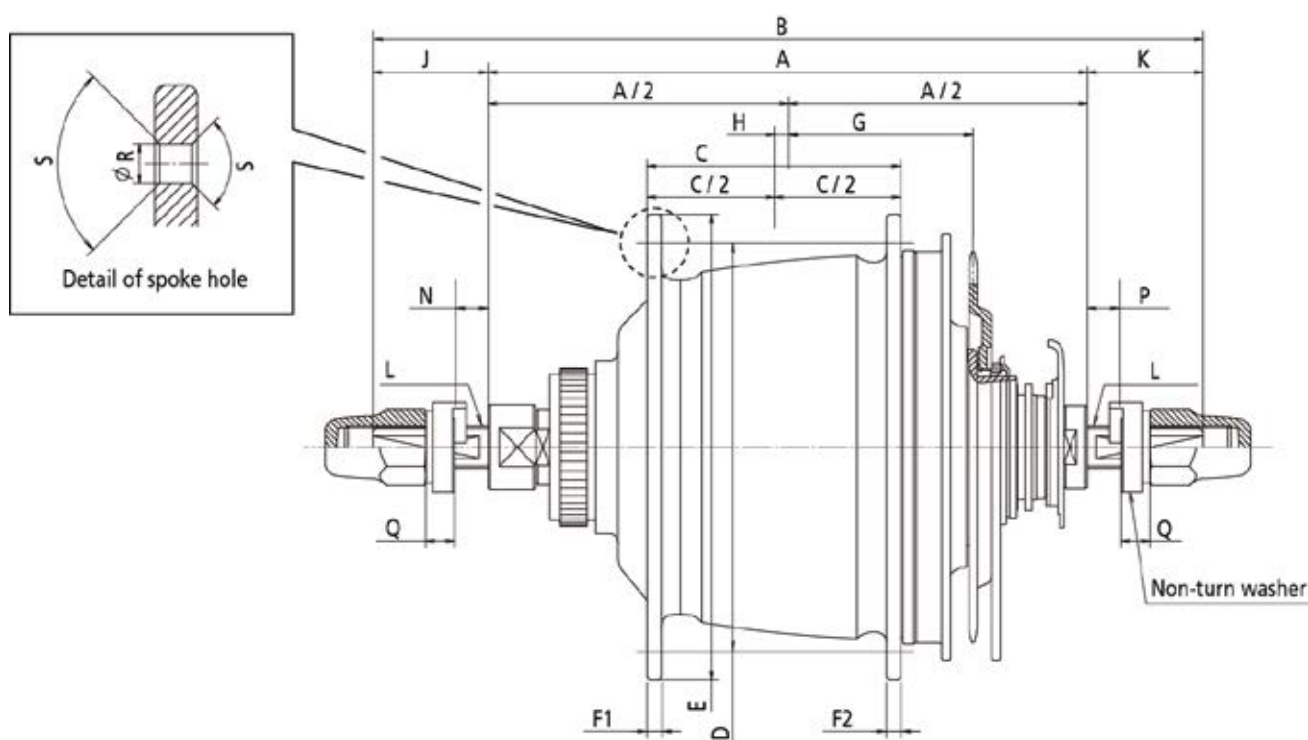

Series		ALFINE		NEXUS			
Function name		INTER-11	INTER-8	INTER-8			
Model No.		SG-S7051-11	SG-S7051-8	SG-C6061-8R	SG-C6061-8C	SG-C6061-8D	SG-C6061-8CD
Speed		11		8			
Gear ratio		409%		307%			
A	Over locknut dim. / O.L.D. (mm)	135					
B	Axle length (mm)	187					
C	Flange distance (mm)	57.3		58.3		57.3	58.3
D	Spoke hole P.C.D. (mm)	92.6					
E	Flange diameter (mm)	104.3		105.2			
F	Flange width (mm): F1 (left)	3.2					
	Flange width (mm): F2 (right)						
G	Chain line (mm): (inward assembly)	41.8					
H	Offset (mm)	3.15		3.1	3.7	3.3	3.7
J	Axle length from hub (left)	26					
K	Axle length from hub (right)						
L	Axle size	BC3 / 8 TPI 26					
N	Rear dropout mounting width (left, includes stay etc.)	5-9					
P	Rear dropout mounting width (right, includes stay etc.)						
Q	Non turn washer width	6.4					
R	Spoke hole diameter (mm)	2.9					
S	Spoke hole chamfer	90°					

Hub dimensions

SG-C6061-8R / SG-C6061-8V / SG-C6061-8C / SG-C6061-8DS / G-C6061-8CD

Series		NEXUS			
Function name		INTER-5E			
Model No.		SG-C7050-5D	SG-C7050-5R	SG-C7050-5C	SG-C7050-5V
Speed		5			
Gear ratio		263%			
Total					
A	Over locknut dim. / O.L.D. (mm)	135			
B	Axle length (mm)	187			
C	Flange distance (mm)	57.3		58.3	
D	Spoke hole P.C.D. (mm)	92.6			
E	Flange diameter (mm)	105.2			
F	Flange width (mm): F1 (left)	3.2			
	Flange width (mm): F2 (right)				
G	Chain line (mm): (inward assembly)	42.2			
H	Offset (mm)	3.2		3.7	
J	Axle length from hub (left)	26			
K	Axle length from hub (right)				
L	Axle size	BC3 / 8 TPI 26			
N	Rear dropout mounting width (left, includes stay etc.)	5-9			
P	Rear dropout mounting width (right, includes stay etc.)				
Q	Non turn washer width	6.4			
R	Spoke hole diameter (mm)	2.9			
S	Spoke hole chamfer	90°			

EV / Spare Parts List

Spare parts list

NEXUS 8-speed Internal Hub w/Coaster Brake SG-C6011-8R / SG-C6011-8R

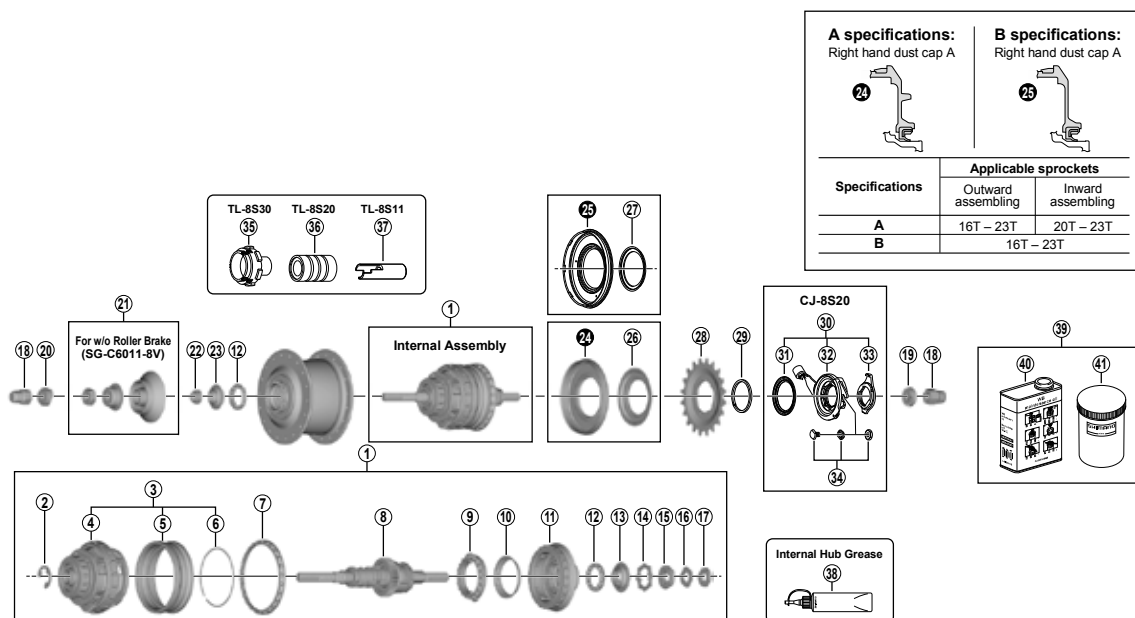

ITEM NO.	SHIMANO CODE NO.	DESCRIPTION
1	Y3EG98010	Internal Assembly (Axle Length 184 mm)
2	Y34R79000	Stop Ring (ø12 / 1.0 mm)
	Y34R79010	Stop Ring (ø12 / 1.3 mm)
	Y34R79020	Stop Ring (ø12 / 1.6 mm)
3	Y3FE98020	Ring Gear Unit
4	Y38X98050	Carrier Unit
5	Y36W07000	Ring Gear 1
6	Y34R80000	Ring Gear 1 Stop Ring
7	Y38X98050	Ball Retainer O (3/16" x 26)
8	Y3EH98050	Hub Axle Unit (Axle Length 184 mm)
9	Y34R98050	Clutch Unit
10	Y34R21000	Return Spring A
11	Y37L98020	Driver Unit B A
12	Y34R98070	Ball Retainer P (3/16" x 13)
13	Y37J98080	Right Hand Cone w/Seal
14	Y34R12000	Driver Plate
15	Y34R98090	Lock Washer
16	Y34R09000	Stop Washer
17	Y33Z07020	Right Hand Lock Nut (3.4 mm)
18	Y31414010	Cap Nut (3/8")
19	Y33Z20500	Non-turn Washer 5R (Yellow)
	Y33M39600	Non-turn Washer 6R (Silver)
	Y33M39700	Non-turn Washer 7R (Black)
	Y34R85010	Non-turn Washer 8R (Dark Blue)
20	Y33M39510	Non-turn Washer 5L (Brown)
	Y33M39610	Non-turn Washer 6L (White)
	Y33M39710	Non-turn Washer 7L (Gray)
	Y34R85000	Non-turn Washer 8L (Dark Green)

ITEM NO.	SHIMANO CODE NO.	DESCRIPTION
21	Y34R98100	Left Hand Dust Cap Unit
22	Y31Z06030	Lock Nut for Left Hand Cone
23	Y35J90000	Left Hand Cone w/Dust Cap
24	Y37G98080	Right Hand Dust Cap A w/Seal (A spec.)
25	Y34R98110	Right Hand Dust Cap A w/Seal (B spec.)
26	Y36R07000	Right Hand Dust Cap C (A spec.)
27	Y34R0E000	Right Hand Dust Cap B (B spec.)
28	Y32203220	Sprocket Wheel 16T (Silver)
	Y32203420	Sprocket Wheel 18T (Silver)
	Y32203520	Sprocket Wheel 19T (Silver)
	Y32203620	Sprocket Wheel 20T (Silver)
	Y33060000	Sprocket Wheel 21T (Silver)
	Y33060100	Sprocket Wheel 22T (Silver)
	Y33060200	Sprocket Wheel 23T (Silver)
29	Y32120100	Snap Ring C
30	Y74Y98120	CJ-8S20 Cassette Joint Unit
31	Y74Y18000	Driver Cap
32	Y74Y98130	CJ-8S20 Cassette Joint
33	Y33Z98020	Cassette Joint Fixing Ring
34	Y74Y98030	Inner Cable Fixing Bolt Unit
35	Y70800300	TL-8S30 Carrier Unit Tool
36	Y70800200	TL-8S20 Right Hand Cone Installation Tool
37	Y70800600	TL-8S11 Right Hand Cone Removal Tool
38	Y04120800	Internal Hub Grease (Net. 100g)
39	Y00298010	WB maintenance oil set
40	Y00201000	WB maintenance oil (1L)
41	Y00201100	Bottle
-	Y34R0D000	Right Hand Hub Cup

Spare parts list

NEXUS 8-speed Internal Hub SG-C6001-8R / SG-C6001-8R

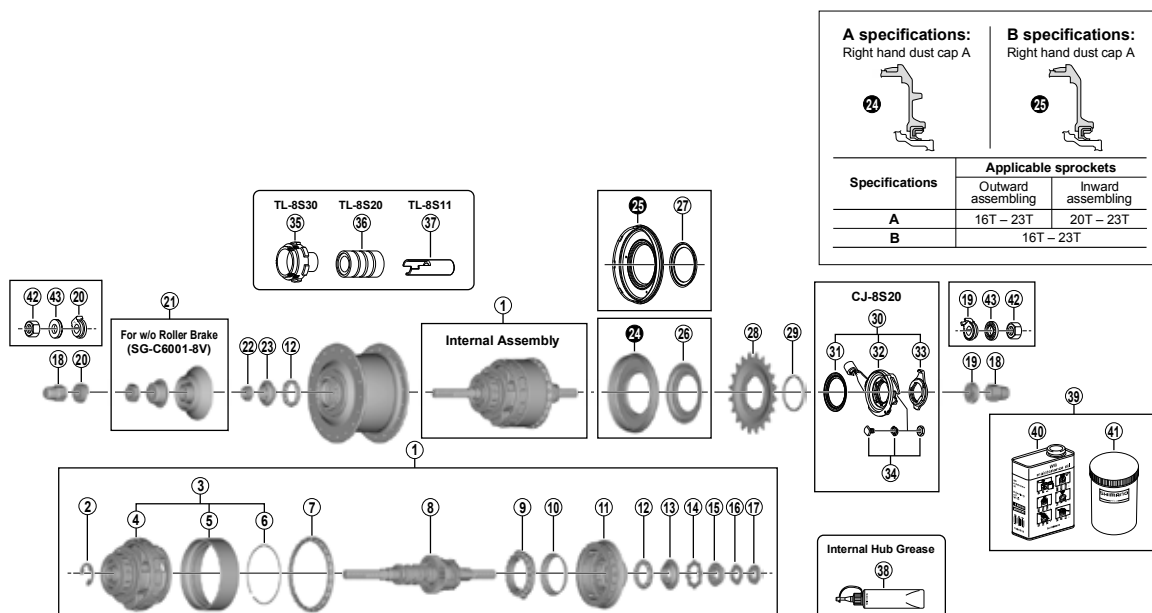

ITEM NO.	SHIMANO CODE NO.	DESCRIPTION
1	Y3EH98010	Internal Assembly (Axle Length 184 mm)
	Y3EH98020	Internal Assembly (Axle Length 203 mm)
2	Y34R79000	Stop Ring (ø12 / 1.0 mm)
	Y34R79010	Stop Ring (ø12 / 1.3 mm)
	Y34R79020	Stop Ring (ø12 / 1.6 mm)
3	Y3EH98030	Ring Gear Unit
4	Y3EH98040	Carrier Unit
5	Y36V22000	Ring Gear 1
6	Y34R80000	Ring Gear 1 Stop Ring
7	Y38X98050	Ball Retainer O (3/16" x 26)
8	Y3EH98050	Hub Axle Unit (Axle Length 184 mm)
	Y3EH98060	Hub Axle Unit (Axle Length 203 mm)
9	Y34R98050	Clutch Unit
10	Y34R21000	Return Spring A
11	Y37J98020	Driver Unit
12	Y34R98070	Ball Retainer P (3/16" x 13)
13	Y37J98080	Right Hand Cone w/Seal
14	Y34R12000	Driver Plate
15	Y34R98090	Lock Washer
16	Y34R09000	Stop Washer
17	Y33Z07020	Right Hand Lock Nut (3.4 mm)
18	Y31414010	Cap Nut (3/8")
19	Y33Z20500	Non-turn Washer 5R (Yellow)
	Y33M39600	Non-turn Washer 6R (Silver)
	Y33M39700	Non-turn Washer 7R (Black)
	Y34R85010	Non-turn Washer 8R (Dark Blue)
20	Y33M39510	Non-turn Washer 5L (Brown)
	Y33M39610	Non-turn Washer 6L (White)
	Y33M39710	Non-turn Washer 7L (Gray)
	Y34R85000	Non-turn Washer 8L (Dark Green)
21	Y34R98100	Left Hand Dust Cap Unit

ITEM NO.	SHIMANO CODE NO.	DESCRIPTION
22	Y31Z06030	Lock Nut for Left Hand Cone
23	Y38P98100	Left Hand Cone w/Dust Cap
24	Y37G98080	Right Hand Dust Cap A w/Seal (A spec.)
25	Y34R98110	Right Hand Dust Cap A w/Seal (B spec.)
26	Y36R07000	Right Hand Dust Cap C (A spec.)
27	Y34R0E000	Right Hand Dust Cap B (B spec.)
28	Y32203220	Sprocket Wheel 16T (Silver)
	Y32203420	Sprocket Wheel 18T (Silver)
	Y32203520	Sprocket Wheel 19T (Silver)
	Y32203620	Sprocket Wheel 20T (Silver)
	Y33060000	Sprocket Wheel 21T (Silver)
	Y33060100	Sprocket Wheel 22T (Silver)
29	Y33060200	Sprocket Wheel 23T (Silver)
	Y32120100	Snap Ring C
30	Y74Y98120	CJ-8S20 Cassette Joint Unit
	Y73E98020	CJ-8S20 Cassette Joint Unit for Belt drive system
31	Y74Y18000	Driver Cap
32	Y74Y98130	CJ-8S20 Cassette Joint
	Y73E98030	CJ-8S20 Cassette Joint for Belt drive system
33	Y33Z98020	Cassette Joint Fixing Ring
34	Y74Y98030	Inner Cable Fixing Bolt Unit
35	Y70800300	TL-8S30 Carrier Unit Tool
36	Y70800200	TL-8S20 Right Hand Cone Installation Tool
37	Y70800600	TL-8S11 Right Hand Cone Removal Tool
38	Y04120800	Internal Hub Grease (Net. 100g)
39	Y00298010	WB maintenance oil set
40	Y00201000	WB maintenance oil (1L)
41	Y00201100	Bottle
42	Y20003000	Hub Nut (9 mm) for Axle Length 203 mm
43	Y22006040	Washer (3.2 mm) for Axle Length 203 mm
-	Y34R0D000	Right Hand Hub Cup

Spare parts list

NEXUS 5-speed Internal Hub
SG-C6001-8C

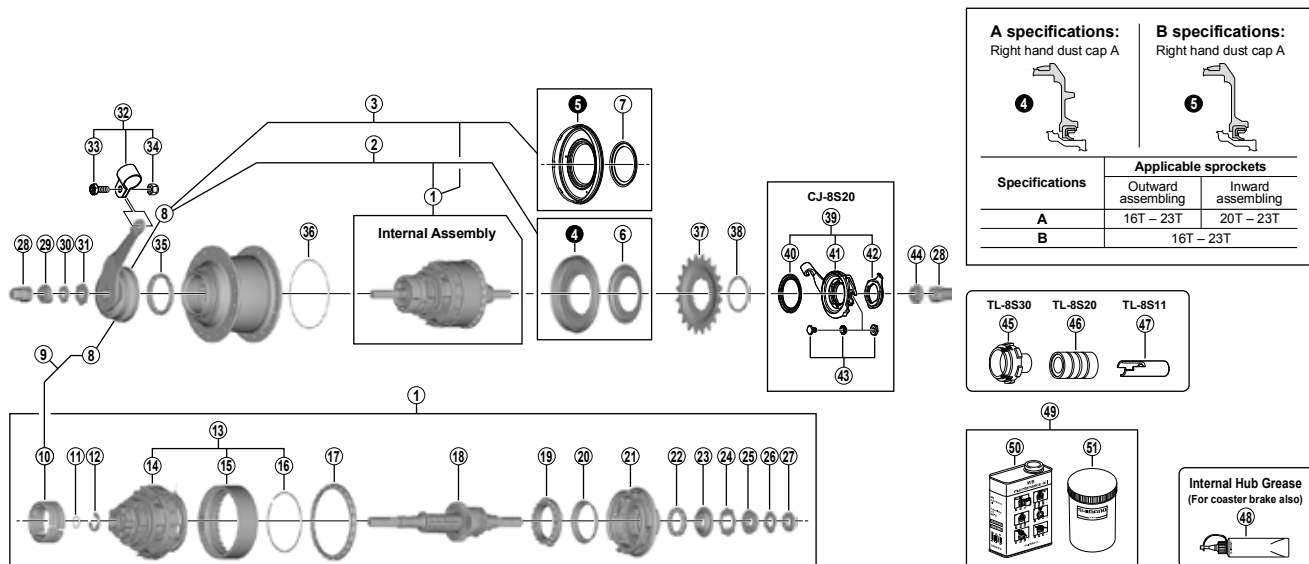

ITEM NO.	SHIMANO CODE NO.	DESCRIPTION
1	Y3EJ98010	Internal Assembly (Axle Length 184 mm)
2	Y3EJ98020	Internal Assembly (Axle Length 184 mm), Brake Arm Unit, Right Hand Dust Cap A & C
3	Y3EJ98030	Internal Assembly (Axle Length 184 mm), Brake Arm Unit, Right Hand Dust Cap A & B
4	Y37G98080	Right Hand Dust Cap A w/Seal (A spec.)
5	Y34R98110	Right Hand Dust Cap A w/Seal (B spec.)
6	Y36R07000	Right Hand Dust Cap C (A spec.)
7	Y34R0E000	Right Hand Dust Cap B (B spec.)
8	Y31N98050	Brake Arm Unit (3 Serration)
9	Y31N98060	Brake Shoe Unit & Brake Arm Unit
10	Y37G98020	Brake Shoe Unit (3 pcs.)
11	Y37E08000	O-Ring
12	Y37G19000	E-Ring
13	Y3EJ98040	Ring Gear Unit
14	Y3EJ98050	Carrier Unit
15	Y35P11010	Ring Gear 1
16	Y34R80000	Ring Gear 1 Stop Ring
17	Y38X98050	Ball Retainer O (3/16" x 26)
18	Y3EJ98060	Hub Axle Unit (Axle Length 184 mm)
19	Y35P98060	Clutch Unit
20	Y34R21000	Return Spring A
21	Y37G98060	Driver Unit
22	Y34R98070	Ball Retainer P (3/16" x 13)
23	Y37J98080	Right Hand Cone w/Seal
24	Y34R12000	Driver Plate
25	Y34R98090	Lock Washer
26	Y34R09000	Stop Washer
27	Y33Z07020	Right Hand Lock Nut (3.4 mm)
28	Y31414010	Cap Nut (3/8")
29	Y33M39510	Non-turn Washer 5L (Brown)
	Y33M39610	Non-turn Washer 6L (White)
	Y33M39710	Non-turn Washer 7L (Gray)
30	Y35P28000	Left Hand Lock Nut (3 mm)
31	Y35P22000	Stop Nut

ITEM NO.	SHIMANO CODE NO.	DESCRIPTION
32	Y33F98090	Brake Arm Clip Unit (5/8")
	Y33F98100	Brake Arm Clip Unit (3/4")
33	Y75M06000	Clip Screw (M6 x 16)
34	Y31727200	Clip Nut
35	Y38R98190	Ball Retainer B (3/16" x 16)
36	Y35J11100	Hub Shell Slide Spring
	Y32203220	Sprocket Wheel 16T (Silver)
	Y32203420	Sprocket Wheel 18T (Silver)
	Y32203520	Sprocket Wheel 19T (Silver)
	Y32203620	Sprocket Wheel 20T (Silver)
	Y33060000	Sprocket Wheel 21T (Silver)
	Y33060100	Sprocket Wheel 22T (Silver)
37	Y33060200	Sprocket Wheel 23T (Silver)
	Y32120100	Snap Ring C
38	Y74Y98120	CJ-8S20 Cassette Joint Unit
	Y73E98020	CJ-8S20 Cassette Joint Unit for Belt drive system
39	Y74Y18000	Driver Cap
	Y74Y98130	CJ-8S20 Cassette Joint
40	Y73E98030	CJ-8S20 Cassette Joint for Belt drive system
	Y33Z98020	Cassette Joint Fixing Ring
41	Y74Y98030	Inner Cable Fixing Bolt Unit
42	Y33Z20500	Non-turn Washer 5R (Yellow)
	Y33M39600	Non-turn Washer 6R (Silver)
	Y33M39700	Non-turn Washer 7R (Black)
43	Y70800300	TL-8S30 Carrier Unit Tool
44	Y70800200	TL-8S20 Right Hand Cone Installation Tool
45	Y70800600	TL-8S11 Right Hand Cone Removal Tool
46	Y04120800	Internal Hub Grease (Net. 100g)
47	Y00298010	WB maintenance oil set
48	Y00201000	WB maintenance oil (1L)
49	Y00201100	Bottle
50	Y34RD0000	Right Hand Hub Cup

Spare parts list

NEXUS 5-speed Internal Hub
SG-C6001-8D

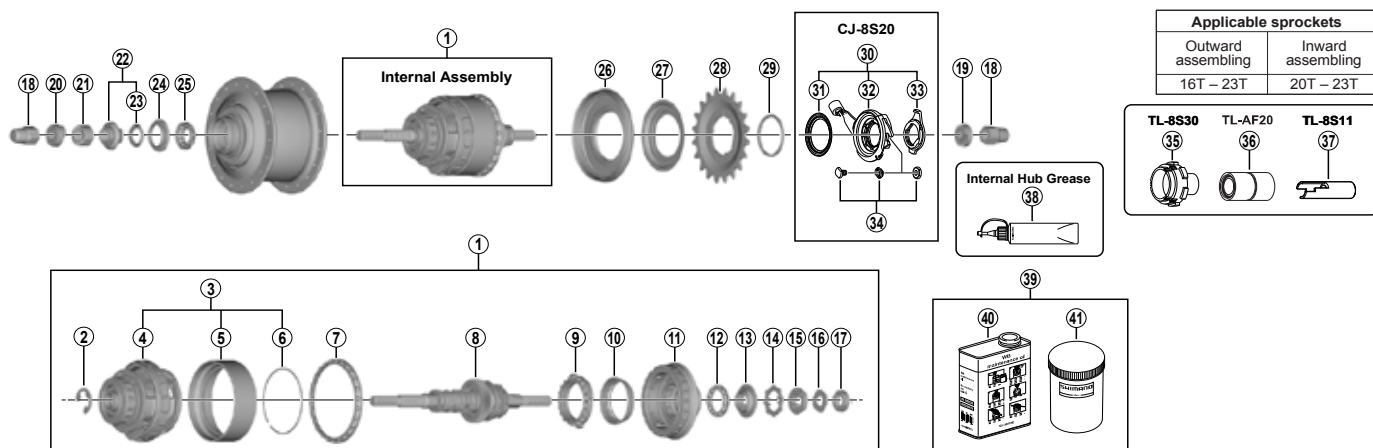

ITEM NO.	SHIMANO CODE NO.	DESCRIPTION
1	Y3EK98010	Internal Assembly (Axle Length 187 mm)
2	Y34R79000	Stop Ring (ø12 / 1.0 mm)
	Y34R79010	Stop Ring (ø12 / 1.3 mm)
	Y34R79020	Stop Ring (ø12 / 1.6 mm)
3	Y3EH98030	Ring Gear Unit
4	Y3EH98040	Carrier Unit
5	Y36V22000	Ring Gear 1
6	Y34R80000	Ring Gear 1 Stop Spring
7	Y38X98050	Ball Retainer O (3/16" x 26)
8	Y3EK98020	Hub Axle Unit (Axle Length 187 mm)
9	Y34R98050	Clutch Unit
10	Y34R21000	Return Spring A
11	Y37J98020	Driver Unit
12	Y34R98070	Ball Retainer P (3/16" x 13)
13	Y37J98080	Right Hand Cone w/Seal
14	Y34R12000	Driver Plate
15	Y34R98090	Lock Washer
16	Y34R09000	Stop Washer
17	Y35Z11000	Right Hand Serated Lock Nut (5.4 mm)
18	Y31414010	Cap Nut (3/8")
19	Y33Z20500	Non-turn Washer 5R (Yellow)
	Y33M39600	Non-turn Washer 6R (Silver)
	Y33M39700	Non-turn Washer 7R (Black)
	Y34R85010	Non-turn Washer 8R (Dark Blue)
20	Y33M39510	Non-turn Washer 5L (Brown)
	Y33M39610	Non-turn Washer 6L (White)
	Y33M39710	Non-turn Washer 7L (Gray)
	Y34R85000	Non-turn Washer 8L (Dark Green)
21	Y35Z19000	Left Hand Serated Lock Nut (10.7 mm)

ITEM NO.	SHIMANO CODE NO.	DESCRIPTION
22	Y33F98090	Left Hand Cone w/Dust Cap & Seal Ring
23	Y33F98100	Seal Ring
24	Y75M06000	Left Hand Inner Dust Cap
25	Y31727200	Ball Retainer (7/32" x 9)
26	Y38R98190	Right Hand Dust Cap A w/Seal
27	Y35J11100	Right Hand Dust Cap C
28	Y32203220	Sprocket Wheel 16T (Silver)
	Y32203420	Sprocket Wheel 18T (Silver)
	Y32203520	Sprocket Wheel 19T (Silver)
	Y32203620	Sprocket Wheel 20T (Silver)
	Y33060000	Sprocket Wheel 21T (Silver)
	Y33060100	Sprocket Wheel 22T (Silver)
29	Y33060200	Sprocket Wheel 23T (Silver)
	Y32120100	Snap Ring C
30	Y74Y98120	CJ-8S20 Cassette Joint Unit
	Y73E98020	CJ-8S20 Cassette Joint Unit for Belt drive system
31	Y74Y18000	Driver Cap
32	Y74Y98130	CJ-8S20 Cassette Joint
	Y73E98030	CJ-8S20 Cassette Joint for Belt drive system
33	Y33Z98020	Cassette Joint Fixing Ring
34	Y74Y98030	Inner Cable Fixing Bolt Unit
35	Y33Z20500	TL-8S30 Carrier Unit Tool
36	Y33M39600	TL-AF20 Right Hand Cone Installation Tool
37	Y33M39700	TL-8S11 Right Hand Cone Removal Tool
38	Y70800300	Internal Hub Grease (Net. 100g)
39	Y70800200	WB maintenance oil set
40	Y70800600	WB maintenance oil (1L)
41	Y04120800	Bottle
-	Y00298010	Right Hand Hub Cup

Spare parts list

NEXUS 8-speed Internal Hub
SG-C6001-8CD

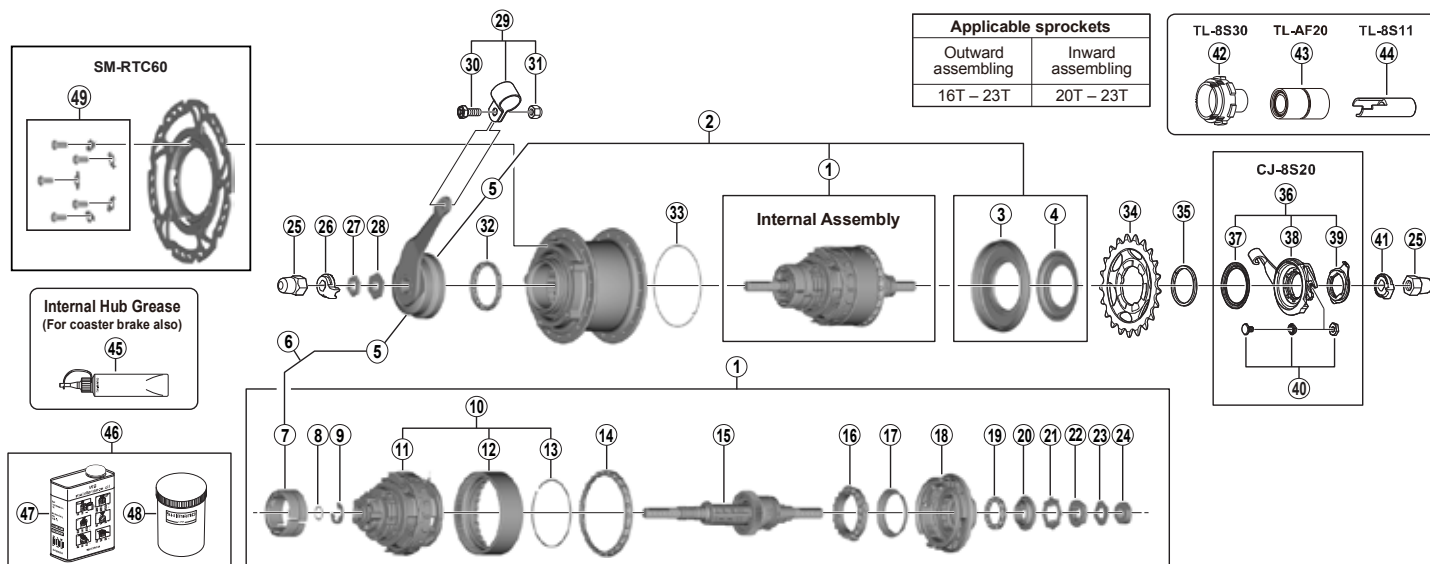

ITEM NO.	SHIMANO CODE NO.	DESCRIPTION
1	Y3EL98010	Internal Assembly (Axle Length 187 mm)
2	Y3EL98020	Internal Assembly (Axle Length 187 mm), Brake Arm Unit, Right Hand Dust Cap A & C
3	Y37G98080	Right Hand Dust Cap A w/Seal
4	Y36R07000	Right Hand Dust Cap C
5	Y38X98030	Brake Arm Unit (3 Serration)
6	Y38X98040	Brake Shoe Unit & Brake Arm Unit
7	Y37G98020	Brake Shoe Unit (3 pcs.)
8	Y37E08000	O-Ring
9	Y37G19000	E-Ring
10	Y3EJ98040	Ring Gear Unit
11	Y3EJ98050	Carrier Unit
12	Y35P11010	Ring Gear 1
13	Y34R80000	Ring Gear 1 Stop Ring
14	Y38X98050	Ball Retainer O (3/16" x 26)
15	Y3EL98030	Hub Axle Unit (Axle Length 187 mm)
16	Y35P98060	Clutch Unit
17	Y34R21000	Return Spring A
18	Y37G98060	Driver Unit
19	Y34R98070	Ball Retainer P (3/16" x 13)
20	Y37J98080	Right Hand Cone w/Seal
21	Y34R12000	Driver Plate
22	Y34R98090	Lock Washer
23	Y34R09000	Stop Washer
24	Y30803020	Right Hand Lock Nut (6 mm)
25	Y31414010	Cap Nut (3/8")
26	Y33M39510	Non-turn Washer 5L (Brown)
	Y33M39610	Non-turn Washer 6L (White)
	Y33M39710	Non-turn Washer 7L (Gray)
27	Y35P28000	Left Hand Lock Nut (3 mm)
28	Y35P22000	Stop Nut
29	Y33F98090	Brake Arm Clip Unit (5/8")
	Y33F98100	Brake Arm Clip Unit (3/4")

ITEM NO.	SHIMANO CODE NO.	DESCRIPTION
30	Y75M06000	Clip Screw (M6 x 16)
31	Y31727200	Clip Nut
32	Y38R98190	Ball Retainer B (3/16" x 16)
33	Y35J11100	Hub Shell Slide Spring
34	Y32203220	Sprocket Wheel 16T (Silver)
	Y32203420	Sprocket Wheel 18T (Silver)
	Y32203520	Sprocket Wheel 19T (Silver)
	Y32203620	Sprocket Wheel 20T (Silver)
	Y33060000	Sprocket Wheel 21T (Silver)
	Y33060100	Sprocket Wheel 22T (Silver)
35	Y33060200	Sprocket Wheel 23T (Silver)
	Y32120100	Snap Ring C
36	Y74Y98120	CJ-8S20 Cassette Joint Unit
	Y73E98020	CJ-8S20 Cassette Joint Unit for Belt drive system
37	Y74Y18000	Driver Cap
38	Y74Y98130	CJ-8S20 Cassette Joint
	Y73E98030	CJ-8S20 Cassette Joint for Belt drive system
39	Y33Z98020	Cassette Joint Fixing Ring
40	Y74Y98030	Inner Cable Fixing Bolt Unit
41	Y33Z20500	Non-turn Washer 5R (Yellow)
	Y33M39600	Non-turn Washer 6R (Silver)
	Y33M39700	Non-turn Washer 7R (Black)
42	Y70800300	TL-8S30 Carrier Unit Tool
43	Y70810000	TL-AF20 Right Hand Cone Installation Tool
44	Y70800600	TL-8S11 Right Hand Cone Removal Tool
45	Y04120800	Internal Hub Grease (Net. 100g)
46	Y00298010	WB maintenance oil set
47	Y00201000	WB maintenance oil (1L)
48	Y00201100	Bottle
49	Y8NA98010	Rotor Fixing Bolt & Lock Washer
-	Y34R0D000	Right Hand Hub Cup

Spare parts list

NEXUS 8-speed Internal Hub SG-C6061-8R/SG-C6061-8V

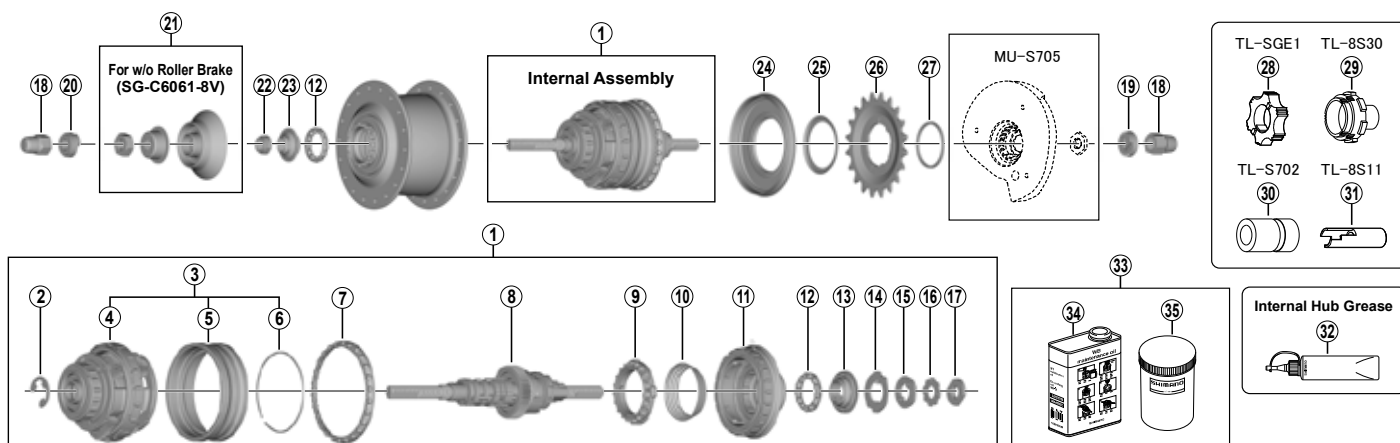

ITEM NO.	SHIMANO CODE NO.	DESCRIPTION
1	Y3EC98010	Internal Assembly (Axle Length 187 mm)
2	Y34R79000	Stop Ring (ø12 / 1.0 mm)
	Y34R79010	Stop Ring (ø12 / 1.3 mm)
	Y34R79020	Stop Ring (ø12 / 1.6 mm)
3	Y3EG98020	Ring Gear Unit
4	Y3EG98030	Carrier Unit
5	Y36W07000	Ring Gear 1
6	Y34R80000	Ring Gear 1 Stop Ring
7	Y38X98050	Ball Retainer O (3/16" x 26)
8	Y3EC98020	Hub Axle Unit (Axle Length 187 mm)
9	Y34R98050	Clutch Unit
10	Y34R21000	Return Spring A
11	Y37L98020	Driver Unit
12	Y34R98070	Ball Retainer P (3/16" x 13)
13	Y37S98040	Right Hand Cone w/Seal
14	Y37S07000	Driver Plate
15	Y37S98050	Lock Washer
16	Y38F17000	Right Hand Lock Nut Washer
17	Y38F16000	Right Hand Lock Nut (3.7 mm)
18	Y31414010	Cap Nut (3/8")
19	Y33Z20500	Non-turn Washer 5R (Yellow)
	Y33M39600	Non-turn Washer 6R (Silver)
	Y33M39700	Non-turn Washer 7R (Black)
	Y34R85010	Non-turn Washer 8R (Dark Blue)

ITEM NO.	SHIMANO CODE NO.	DESCRIPTION
20	Y33M39510	Non-turn Washer 5L (Brown)
	Y33M39610	Non-turn Washer 6L (White)
	Y33M39710	Non-turn Washer 7L (Gray)
	Y34R85000	Non-turn Washer 8L (Dark Green)
21	Y34R98100	Left Hand Dust Cap Unit
22	Y31Z06030	Lock Nut for Left Hand Cone
23	Y35J90000	Left Hand Cone w/Dust Cap
24	Y34R98110	Right Hand Dust Cap A w/Seal
25	Y34R0E000	Right Hand Dust Cap
26	Y32203220	Sprocket Wheel 16T (Silver)
	Y32203420	Sprocket Wheel 18T (Silver)
	Y32203520	Sprocket Wheel 19T (Silver)
	Y32203620	Sprocket Wheel 20T (Silver)
	Y33060000	Sprocket Wheel 21T (Silver)
	Y33060100	Sprocket Wheel 22T (Silver)
27	Y32120100	Sprocket Wheel 23T (Silver)
27	Y32120100	Snap Ring C
28	Y20W10000	TL-SGE1 1st Gear Set Tool
29	Y70800300	TL-8S30 Carrier Unit Tool
30	Y13098022	TL-S702 Right Hand Cone Installation Tool
31	Y70800600	TL-8S11 Right Hand Cone Removal Tool
32	Y04120800	Internal Hub Grease (Net. 100g)
33	Y00298010	WB maintenance oil set
34	Y00201000	WB maintenance oil (1L)
35	Y00201100	Bottle
-	Y34R0D000	Right Hand Hub Cup

Spare parts list

NEXUS 8-speed Internal Hub
SG-C6061-8C

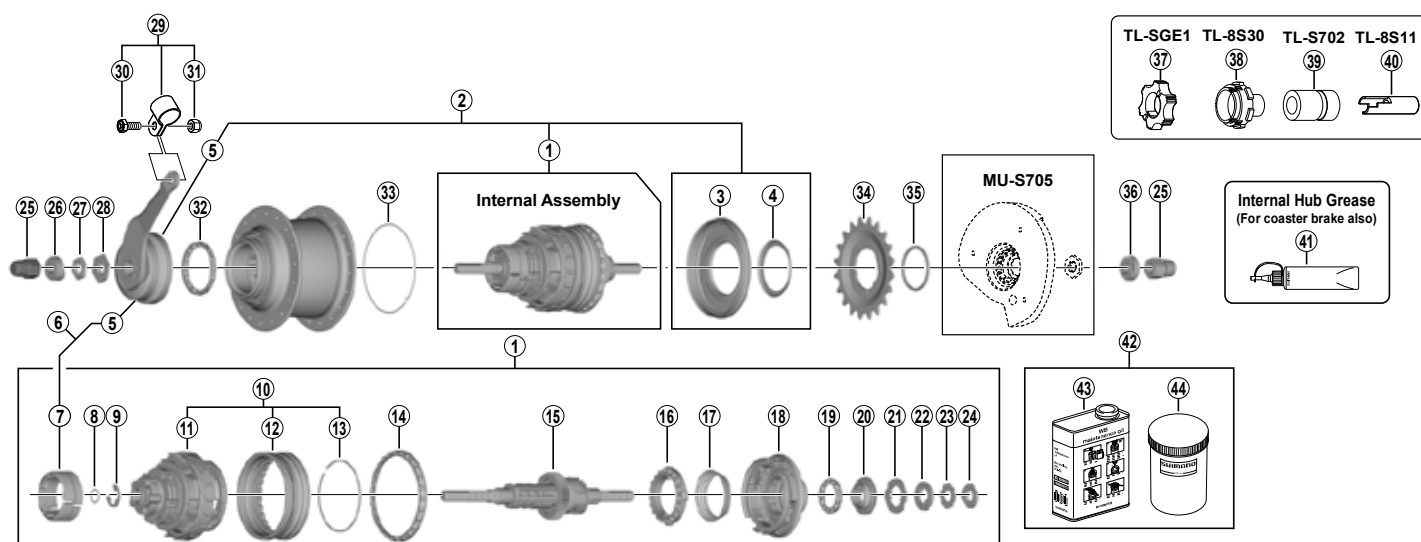

ITEM NO.	SHIMANO CODE NO.	DESCRIPTION
1	Y3ED98010	Internal Assembly (Axle Length 187 mm)
2	Y3ED98020	Internal Assembly (Axle Length 187 mm), Brake Arm Unit, Right Hand Dust Cap A & B
3	Y34R98110	Right Hand Dust Cap A w/Seal (B spec.)
4	Y34R0E000	Right Hand Dust Cap B (B spec.)
5	Y31N98050	Brake Arm Unit (3 Serration)
6	Y31N98060	Brake Shoe Unit & Brake Arm Unit
7	Y37G98020	Brake Shoe Unit (3 pcs.)
8	Y37E08000	O-Ring
9	Y37G19000	E-Ring
10	Y3ED98030	Ring Gear Unit
11	Y3ED98040	Carrier Unit
12	Y35P11010	Ring Gear 1
13	Y34R80000	Ring Gear 1 Stop Ring
14	Y38X98050	Ball Retainer O (3/16" x 26)
15	Y3ED98050	Hub Axle Unit (Axle Length 187 mm)
16	Y35P98060	Clutch Unit
17	Y34R21000	Return Spring A
18	Y37H98050	Driver Unit
19	Y34R98070	Ball Retainer P (3/16" x 13)
20	Y37S98040	Right Hand Cone w/Seal
21	Y37S07000	Driver Plate
22	Y37S98050	Lock Washer
23	Y38F17000	Right Hand Lock Nut Washer
24	Y38F16000	Right Hand Lock Nut
25	Y31414010	Cap Nut (3/8")
26	Y33M39510	Non-turn Washer 5L (Brown)
	Y33M39610	Non-turn Washer 6L (White)
	Y33M39710	Non-turn Washer 7L (Gray)

ITEM NO.	SHIMANO CODE NO.	DESCRIPTION
27	Y35P28000	Left Hand Lock Nut (3 mm)
28	Y35P22000	Stop Nut
29	Y33F98090	Brake Arm Clip Unit (5/8")
	Y33F98100	Brake Arm Clip Unit (3/4")
30	Y75M06000	Clip Screw (M6 x 16)
31	Y31727200	Clip Nut
32	Y38R98190	Ball Retainer B (3/16" x 16)
33	Y35J11100	Hub Shell Slide Spring
34	Y32203220	Sprocket Wheel 16T (Silver)
	Y32203420	Sprocket Wheel 18T (Silver)
	Y32203520	Sprocket Wheel 19T (Silver)
	Y32203620	Sprocket Wheel 20T (Silver)
	Y33060000	Sprocket Wheel 21T (Silver)
	Y33060100	Sprocket Wheel 22T (Silver)
35	Y33060200	Sprocket Wheel 23T (Silver)
35	Y32120100	Snap Ring C
36	Y33220500	Non-turn Washer 5R (Yellow)
	Y33M39600	Non-turn Washer 6R (Silver)
	Y33M39700	Non-turn Washer 7R (Black)
37	Y20W10000	TL-SGE1 1st Gear Set Tool
38	Y70800300	TL-8S30 Carrier Unit Tool
39	Y13098022	TL-S702 Right Hand Cone Installation Tool
40	Y70800600	TL-8S11 Right Hand Cone Removal Tool
41	Y04120800	Internal Hub Grease (Net. 100g)
42	Y00298010	WB maintenance oil set
43	Y00201000	WB maintenance oil (1L)
44	Y00201100	Bottle
-	Y34R0D000	Right Hand Hub Cup

Spare parts list

NEXUS 8-speed Internal Hub
SG-C6061-8D

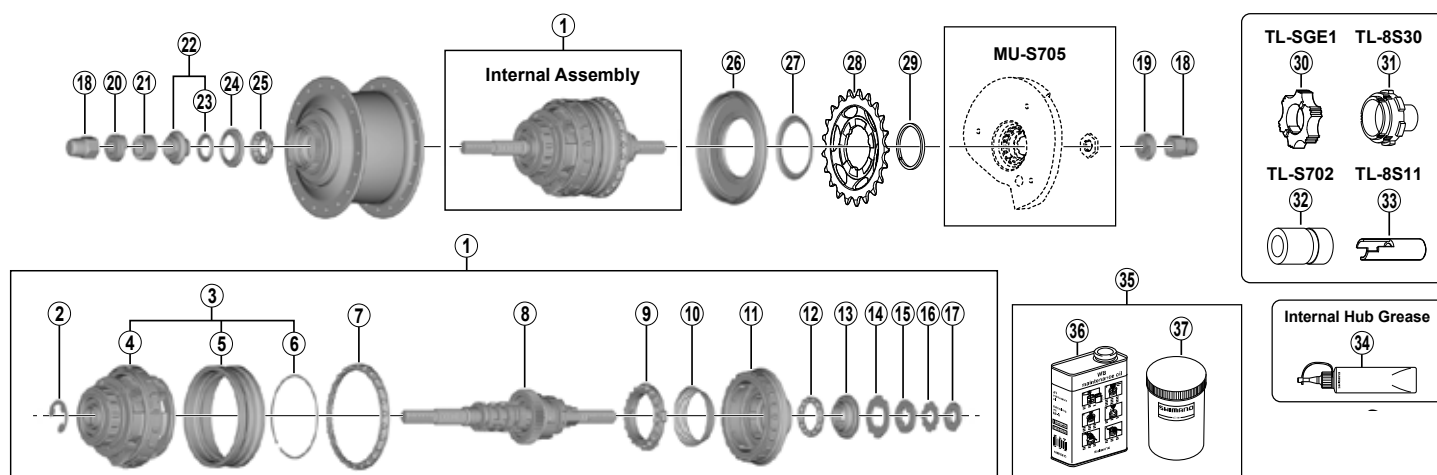

ITEM NO.	SHIMANO CODE NO.	DESCRIPTION
1	Y3EE98010	Internal Assembly (Axle Length 187 mm)
2	Y34R79000	Stop Ring (ø12 / 1.0 mm)
	Y34R79010	Stop Ring (ø12 / 1.3 mm)
	Y34R79020	Stop Ring (ø12 / 1.6 mm)
3	Y3EG98020	Ring Gear Unit
4	Y3EG98030	Carrier Unit
5	Y36W07000	Ring Gear 1
6	Y34R80000	Ring Gear 1 Stop Spring
7	Y38X98050	Ball Retainer O (3/16" x 26)
8	Y3EE98020	Hub Axle Unit (Axle Length 187 mm)
9	Y34R98050	Clutch Unit
10	Y34R21000	Return Spring A
11	Y37L98020	Driver Unit
12	Y34R98070	Ball Retainer P (3/16" x 13)
13	Y37S98040	Right Hand Cone w/Seal
14	Y37S07000	Driver Plate
15	Y37S98050	Lock Washer
16	Y38F17000	Right Hand Lock Nut Washer
17	Y38F16000	Right Hand Lock Nut (3.7 mm)
18	Y31414010	Cap Nut (3/8")
19	Y33Z20500	Non-turn Washer 5R (Yellow)
	Y33M39600	Non-turn Washer 6R (Silver)
	Y33M39700	Non-turn Washer 7R (Black)
	Y34R85010	Non-turn Washer 8R (Dark Blue)
20	Y33M39510	Non-turn Washer 5L (Brown)
	Y33M39610	Non-turn Washer 6L (White)
	Y33M39710	Non-turn Washer 7L (Gray)
	Y34R85000	Non-turn Washer 8L (Dark Green)

ITEM NO.	SHIMANO CODE NO.	DESCRIPTION
21	Y35Z19000	Left Hand Serated Lock Nut (10.7 mm)
22	Y31L98040	Left Hand Cone w/Dust Cap & Seal Ring
23	Y37710000	Seal Ring
24	Y32T08100	Left Hand Inner Dust Cap
25	Y36U98030	Ball Retainer (7/32" x 9)
26	Y34R98110	Right Hand Dust Cap A w/Seal
27	Y34R0E000	Right Hand Dust Cap B
28	Y32203220	Sprocket Wheel 16T (Silver)
	Y32203420	Sprocket Wheel 18T (Silver)
	Y32203520	Sprocket Wheel 19T (Silver)
	Y32203620	Sprocket Wheel 20T (Silver)
	Y33060000	Sprocket Wheel 21T (Silver)
	Y33060100	Sprocket Wheel 22T (Silver)
	Y33060200	Sprocket Wheel 23T (Silver)
29	Y32120100	Snap Ring C
30	Y20W10000	TL-SGE1 1st Gear Set Tool
31	Y70800300	TL-8S30 Carrier Unit Tool
32	Y13098022	TL-S702 Right Hand Cone Installation Tool
33	Y70800600	TL-8S11 Right Hand Cone Removal Tool
34	Y04120800	Internal Hub Grease (Net. 100g)
35	Y00298010	WB maintenance oil set
36	Y00201000	WB maintenance oil (1L)
37	Y00201100	Bottle
-	Y34R0D000	Right Hand Hub Cup

Spare parts list

NEXUS 8-speed Internal Hub
SG-C6061-8CD

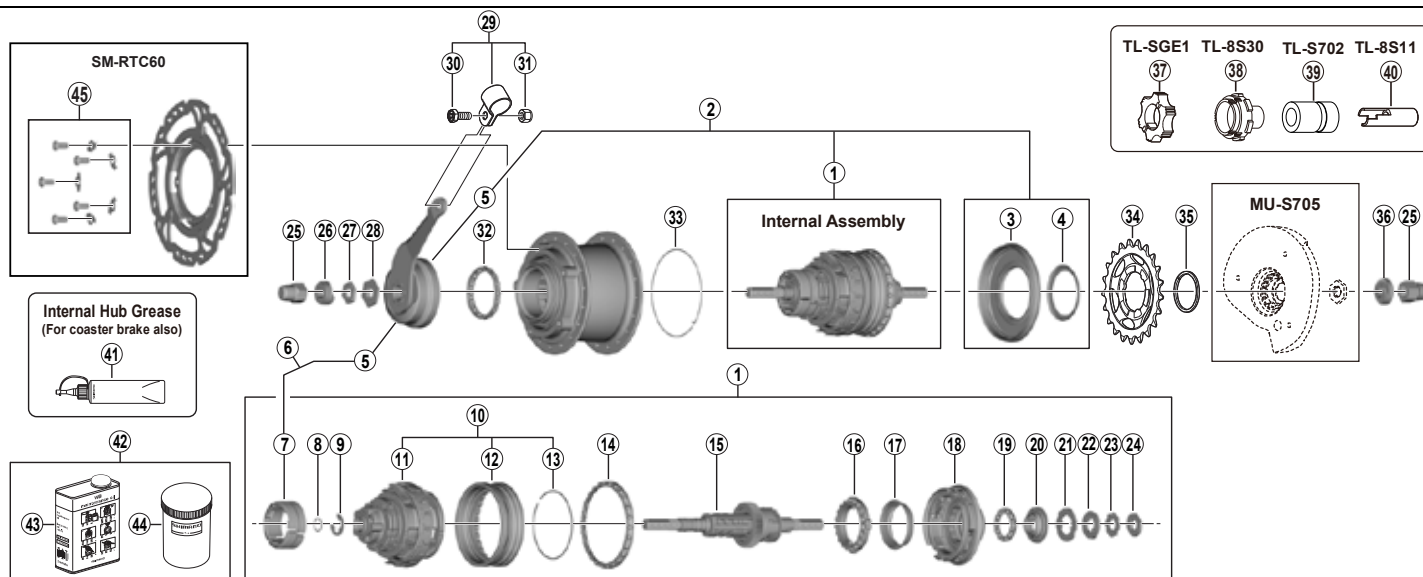

ITEM NO.	SHIMANO CODE NO.	DESCRIPTION
1	Y3EF98010	Internal Assembly (Axle Length 187 mm)
2	Y3EF98020	Internal Assembly (Axle Length 187 mm), Brake Arm Unit, Right Hand Dust Cap A & B
3	Y34R98110	Right Hand Dust Cap A w/Seal
4	Y34R0E000	Right Hand Dust Cap B
5	Y38X98030	Brake Arm Unit (3 Serration)
6	Y38X98040	Brake Shoe Unit & Brake Arm Unit
7	Y37G98020	Brake Shoe Unit (3 pcs.)
8	Y37E08000	O-Ring
9	Y37G19000	E-Ring
10	Y3ED98030	Ring Gear Unit
11	Y3ED98040	Carrier Unit
12	Y35P11010	Ring Gear 1
13	Y34R80000	Ring Gear 1 Stop Ring
14	Y38X98050	Ball Retainer O (3/16" x 26)
15	Y3EF98030	Hub Axle Unit (Axle Length 187 mm)
16	Y35P98060	Clutch Unit
17	Y34R21000	Return Spring A
18	Y37H98050	Driver Unit
19	Y34R98070	Ball Retainer P (3/16" x 13)
20	Y37S98040	Right Hand Cone w/Seal
21	Y37S07000	Driver Plate
22	Y37S98050	Lock Washer
23	Y38F17000	Right Hand Lock Nut Washer
24	Y38F16000	Right Hand Lock Nut
25	Y31414010	Cap Nut (3/8")
26	Y33M39510	Non-turn Washer 5L (Brown)
	Y33M39610	Non-turn Washer 6L (White)
	Y33M39710	Non-turn Washer 7L (Gray)
27	Y35P28000	Left Hand Lock Nut (3 mm)

ITEM NO.	SHIMANO CODE NO.	DESCRIPTION
28	Y35P22000	Stop Nut
29	Y33F98090	Brake Arm Clip Unit (5/8")
	Y33F98100	Brake Arm Clip Unit (3/4")
30	Y75M06000	Clip Screw (M6 x 16)
31	Y31727200	Clip Nut
32	Y38R98190	Ball Retainer B (3/16" x 16)
33	Y35J11100	Hub Shell Slide Spring
34	Y32203220	Sprocket Wheel 16T (Silver)
	Y32203420	Sprocket Wheel 18T (Silver)
	Y32203520	Sprocket Wheel 19T (Silver)
	Y32203620	Sprocket Wheel 20T (Silver)
	Y33060000	Sprocket Wheel 21T (Silver)
	Y33060100	Sprocket Wheel 22T (Silver)
35	Y33060200	Sprocket Wheel 23T (Silver)
	Y32120100	Snap Ring C
36	Y33Z20500	Non-turn Washer 5R (Yellow)
	Y33M39600	Non-turn Washer 6R (Silver)
	Y33M39700	Non-turn Washer 7R (Black)
37	Y20W10000	TL-SGE1 1st Gear Set Tool
38	Y70800300	TL-8S30 Carrier Unit Tool
39	Y13098022	TL-S702 Right Hand Cone Installation Tool
40	Y70800600	TL-8S11 Right Hand Cone Removal Tool
41	Y04120800	Internal Hub Grease (Net. 100g)
42	Y00298010	WB maintenance oil set
43	Y00201000	WB maintenance oil (1L)
44	Y00201100	Bottle
45	Y8NA98010	Rotor Fixing Bolt & Lock Washer
-	Y34R0D000	Right Hand Hub Cup

Spare parts list

NEXUS REVOSHIFT Shifter
SL-C6000-8 8-speed

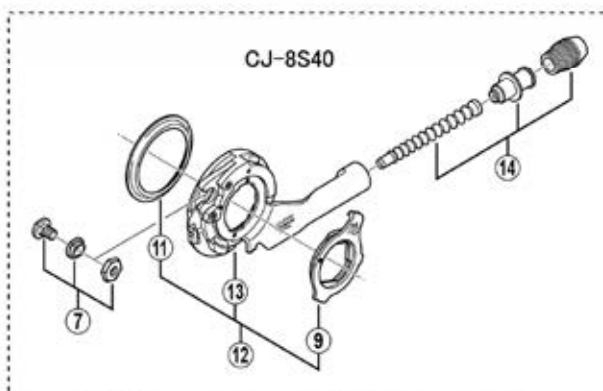
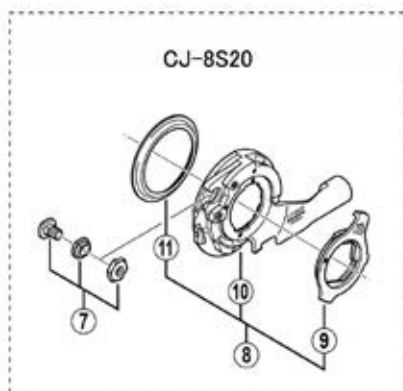
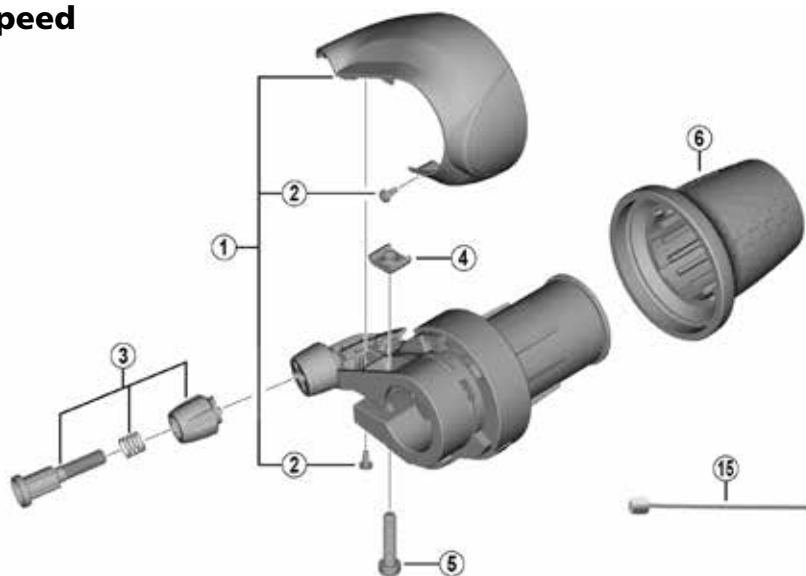

ITEM NO.	SHIMANO CODE NO.	DESCRIPTION
1	Y0EA98010	Indicator Cover & Fixing Screws (Silver)
	Y0EA98020	Indicator Cover & Fixing Screws (Black)
2	Y6F004020	Cover Fixing Screw (Silver)
	Y6F004000	Cover Fixing Screw (Black)
3	Y01A98010	Cable Adjusting Bolt Unit
4	Y6NA08000	Clamp Nut
5	Y6F409100	Clamp Screw (M4 x 18.7)
6	Y6FD14000	Grip
7	Y74Y98030	Inner Cable Fixing Bolt Unit
8	Y74Y98120	CJ-8S20 Cassette Joint Unit
9	Y33Z98020	Cassette Joint Fixing Ring
10	Y74Y98130	CJ-8S20 Cassette Joint
11	Y74Y18000	Driver Cap
12	Y74Y98140	CJ-8S40 Cassette Joint Unit
13	Y74Y98150	CJ-8S40 Cassette Joint
14	Y74Y98160	Outer Casing Holder Unit
15	Y60098911	hift inner cable stainless steel <ul style="list-style-type: none"> • Stainless steel inner cable • ø 1.2 mm x 2100 mm incl. inner end cap

Nexus V-Brake Lever (4-Finger)
BL-C6000-S Silver Version
BL-C6000-L Black Version



ITEM NO.	SHIMANO CODE NO.	DESCRIPTION
1	Y8AN98010	Cable Adjusting Bolt (M10 x 16) & Nut
2	Y6BX87000	Reach Adjusting Bolt (M4 x 10.3)
3	Y8AC04000	Clamp Bolt (M6 x 16)

NEXUS Brake Lever
BL-C6010

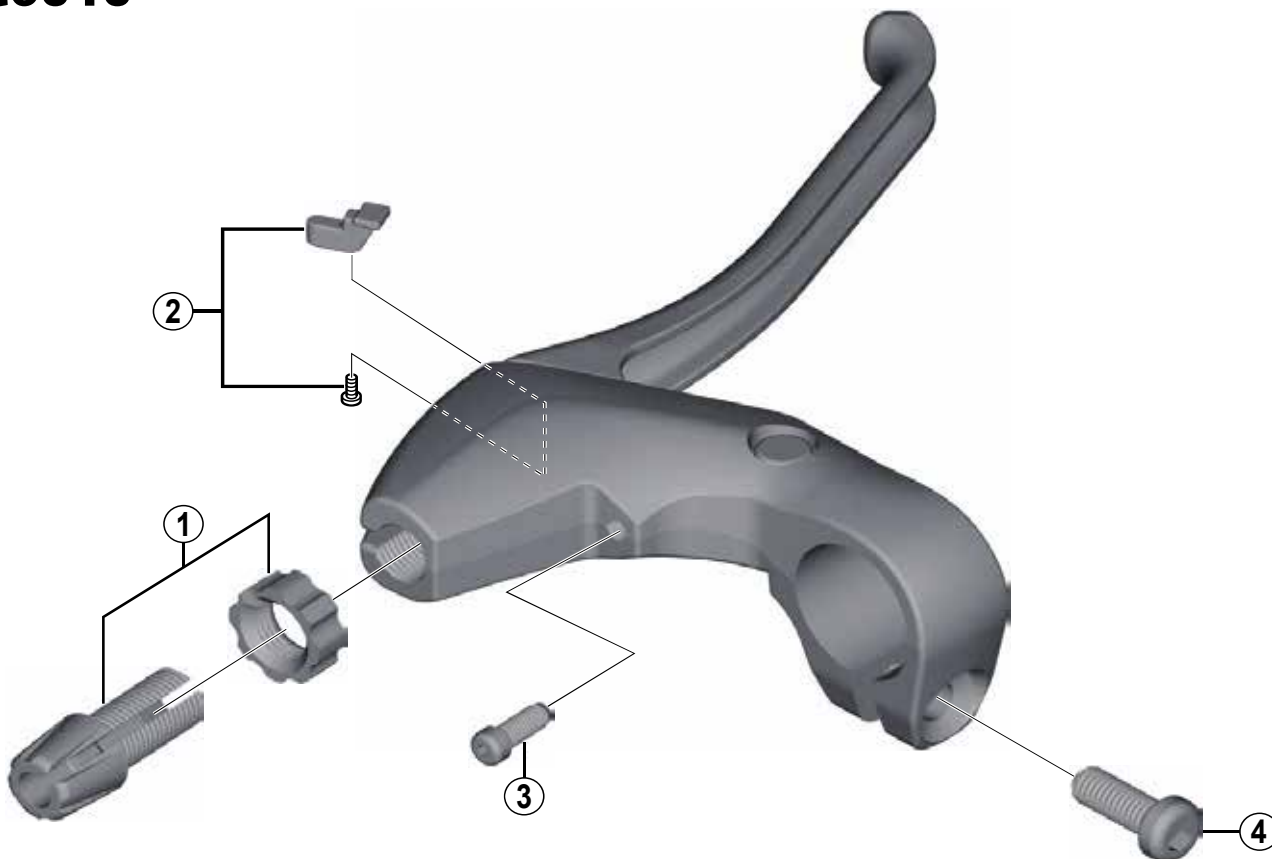

ITEM NO.	SHIMANO CODE NO.	DESCRIPTION
1	Y8AN98010	Cable Adjusting Bolt (M10 x 16) & Nut
2	Y8NL98010	Adjusting Block & Screw
3	Y6BX87000	Reach Adjusting Bolt (M4 x 10.3)
4	Y8AC04000	Clamp Bolt (M6 x 16)

Spare parts list

SHIMANO NEXUS Cassette Joint
CJ-8S40

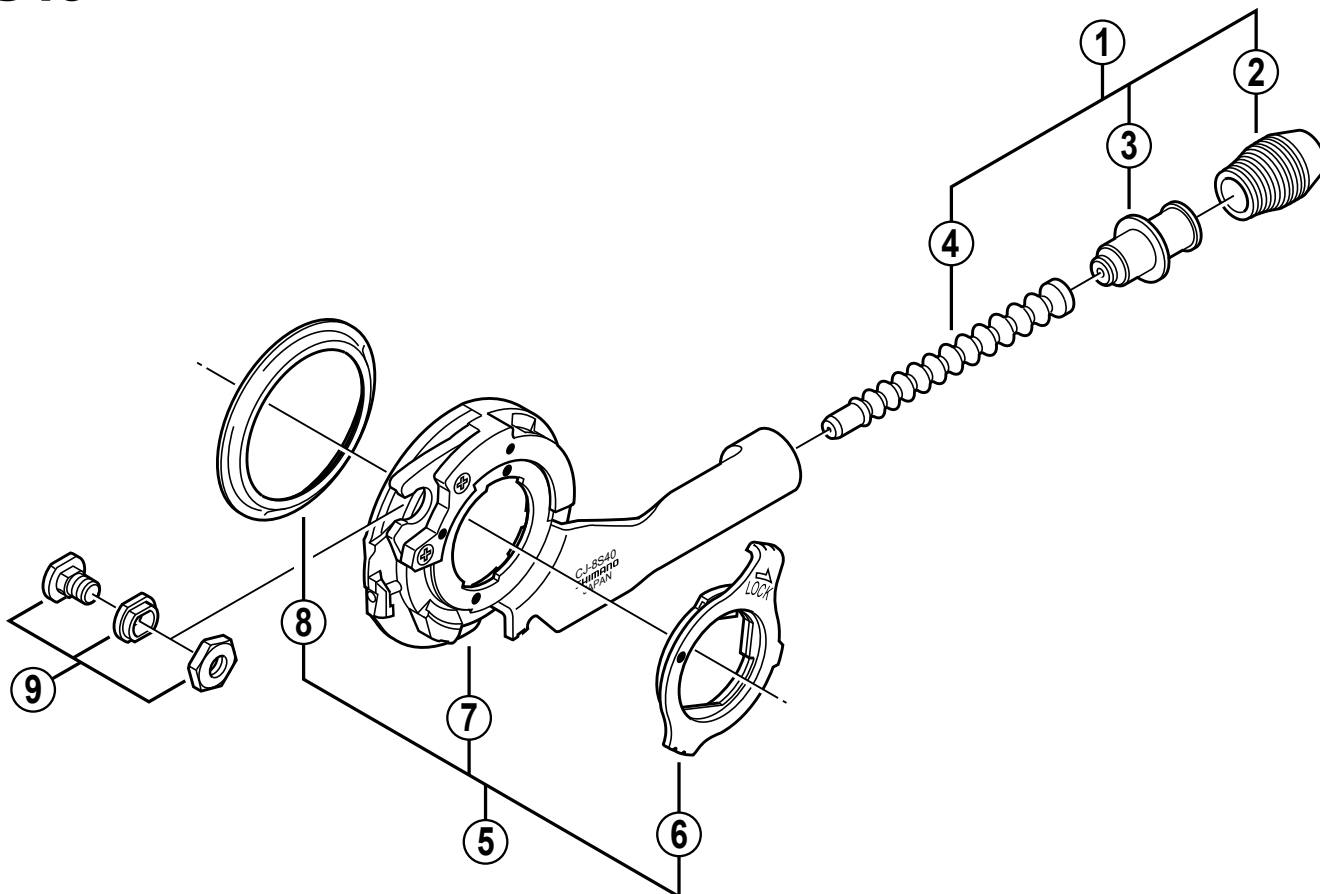

ITEM NO.	SHIMANO CODE NO.	DESCRIPTION
1	Y-74Y98160	Outer Casing Holder Unit
2	Y-74Y27000	Rubber Cover
3	Y-74Y28000	Outer Casing Holder
4	Y-74Y30200	Rubber Bellows
5	Y-74Y98140	Cassette Joint Unit
6	Y-33Z98020	Cassette Joint Fixing Ring
7	Y-74Y98150	Cassette Joint
8	Y-74Y18000	Driver Cap
9	Y-74Y98030	Inner Cable Fixing Bolt Unit