

SHIMANO  
*ALFINE*



**INTER 11**

**SERVICE MANUAL**

**SG-S7001-11**

**SG-S7051-11**

# CONTENTS

<b>Introduction of INTER-11</b> .....	<b>2</b>
<b>Dealer's Manual</b> .....	<b>5</b>
<b>SG-S7001-11</b>	
• INSTALLATION	
• ADJUSTMENT	
• MAINTENANCE	
<b>SG-S7051-11</b>	
• INSTALLATION	
• MAINTENANCE	
<b>Troubleshooting</b> .....	<b>70</b>
<b>Disassembly &amp; Assembly</b> .....	<b>74</b>
<b>Required Tools &amp; Parts</b>	
<b>Replacing the Internal Assembly</b>	
<b>Disassembling the Internal Assembly</b>	
<b>Assembling the Internal Assembly</b>	
<b>Changing Oil</b>	
<b>Service Parts &amp; Tools</b> .....	<b>97</b>
<b>Cassette Joint</b>	
<b>Measurement Tool</b>	
<b>NEXUS non-turn washers</b>	
<b>Interchangeability</b> .....	<b>100</b>
<b>Hub dimensions (Over Locknut Dimensions and Axle)</b> .....	<b>102</b>
<b>EV / Spare Parts List</b> .....	<b>107</b>



## SHIMANO ALFINE Internal Geared Hub Disk Brake 11-speed

### **E**-BIKE DESIGN

The SHIMANO ALFINE S7001-11 hub offers a wide 409% gear range and an improved internal structure for better gear engagement. It is approved for E-BIKE and non E-BIKE use and is available in black and silver

- Improved internal structure for better gear engagement
- Smooth shifting performance
- Improved performance for both E-BIKE and non-E-BIKE usage



SG-S7001-11  
SG-S7051-11

## TECHNOLOGIES

### INTER 11 INTER-11

#### SHIMANO ALFINE 11-speed

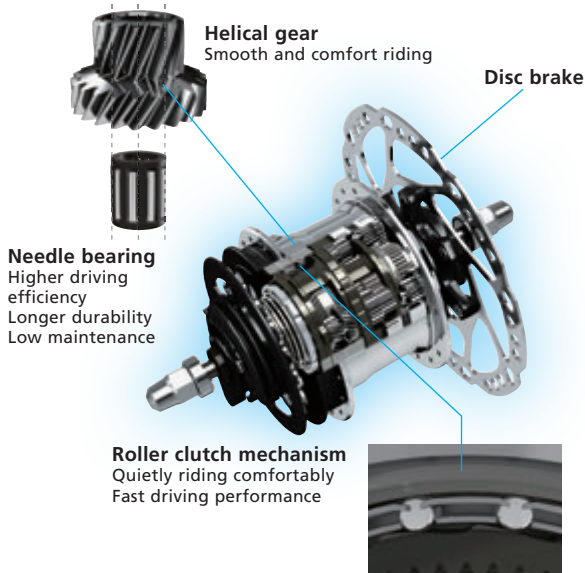

#### Wide Gear Ratio Broad terrain riding support

##### Distance travelled per crank revolution (700C)

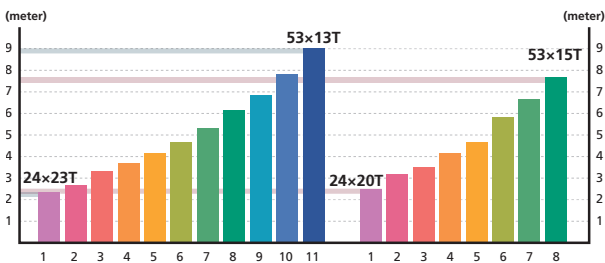

The diagram above shows distance traveled per crank revolution.

If we compare with chainring/sprocket combination rear derailleur system offers, 1st gear of SG-S7001-11 offers as same gear as 24 tooth for chainring, 23 tooth for sprocket. 11th gear of SG-S7001-11 offers as same gear as 53 tooth for chainring, 13 tooth for sprocket. It covers wide range as a total.

### Gear Change Support

SHIMANO gear change support mechanism utilizes some portion of pedaling force at down shifting. The result is a quick and precise downshift with very light feeling. For the automatic shifting system, this gear change support mechanism is the key. Shifting effort is reduced to the point where the hub can be shifted through a small low-torque DC motor. Less electricity is required, so a smaller battery allows the system to be lighter and more compact.

Equipped: SHIMANO ALFINE/SHIMANO NEXUS INTER-8/ SHIMANO NEXUS INTER-3

#### 40% less shifting force required

Pedaling force is applied against the sleeve to help overcome sleeve return pressure and execute the shift.

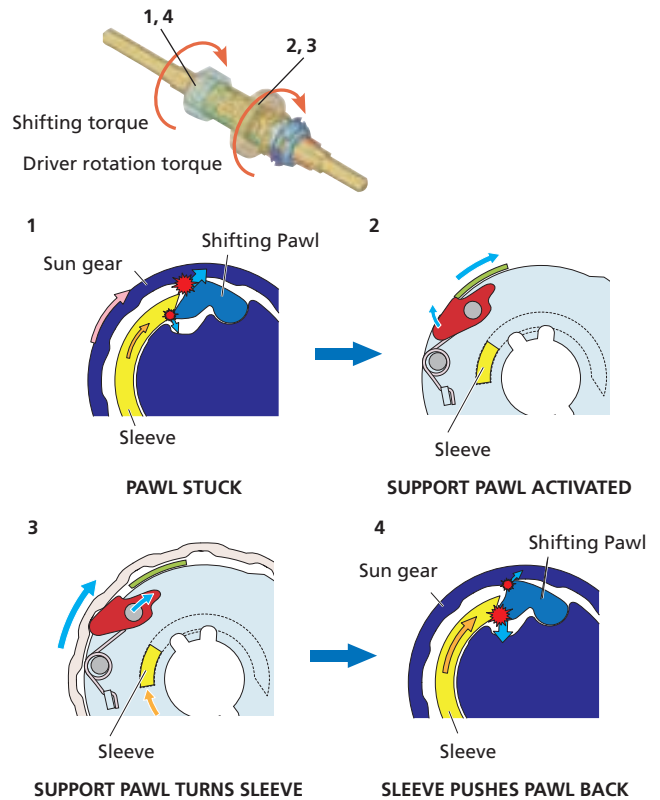

## TECHNOLOGIES

### *Labyrinth & Contact Sealing*

Specifically designed seals inside the hub shut out mud, dust, dirt and moisture and protect the bearing mechanisms, realizing low maintenance as well as longer service life.

This maintains the original performance for a longer period of time under unfavorable environmental conditions.



Labyrinth & contact seal (road)

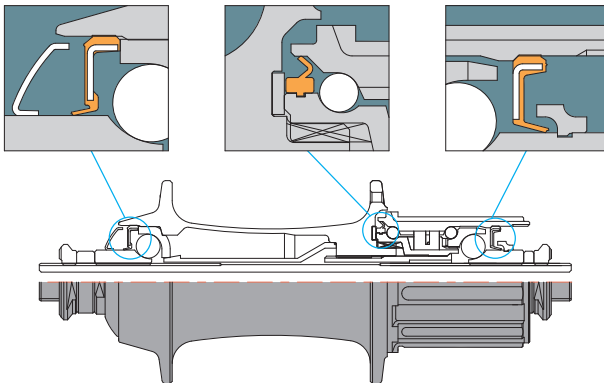

### CENTER LOCK System

The CENTER LOCK system makes an easy disc brake rotor installation possible with spline mount and a lock ring. The lock ring mounting system reduces the total working hours by shortening the amount of time of both installation and de-installation. In addition, the secure fixing by the spline mount enhances precision and rigidity while improving braking efficiency.

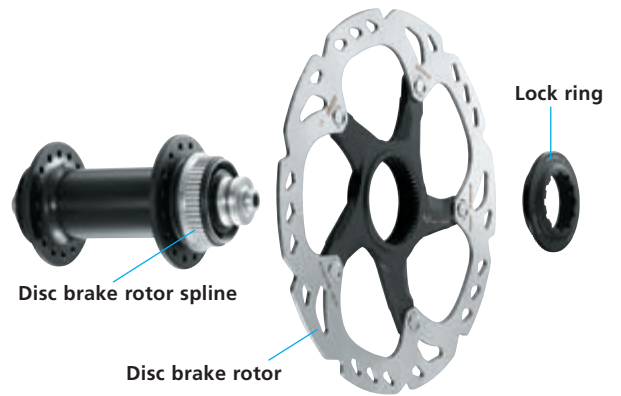



# Dealer's Manual

**SG-S7001-11**

# INSTALLATION

## Installation of the sprocket to the hub

Place the right-hand dust cap B/right-hand dust cap C onto the driver on the right side of the hub body.

Next, install the sprocket and secure it in place with the snap ring.

Specifications	Applicable sprockets	
	Outward assembling	Inward assembling
A	16T-23T	20T-23T
B	16T-23T	

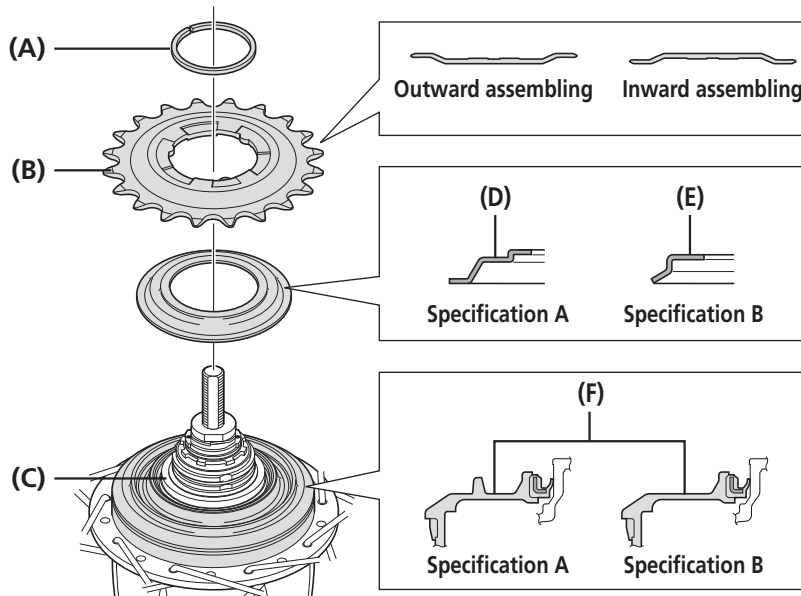

- (A) Snap ring
- (B) Sprocket
- (C) Driver
- (D) Right-hand dust cap C
- (E) Right-hand dust cap B
- (F) Right-hand dust cap A

### NOTICE

Note the orientation of the right-hand dust cap.

#### Specification A

If the sprocket is an inward assembling sprocket with 19T or fewer or for belt drive specifications, right-hand dust cap A will come into contact with the chain or pulley so specification B should be used instead.

#### Specification B

If the sprocket is an inward assembling sprocket with 16T and 3 mm teeth or for belt drive specifications, remove right-hand dust cap B before use.



Click here for the latest Dealer's Manual

<https://si.shimano.com/DM/SG0004>

## Installation of the CS-S500 sprocket with chain guard

1

Install the chain guard to the right hand dust cap of the hub body, and then install right hand dust cap B to the driver.

Install the right-hand dust cap B in the orientation (z).

- (A) Right hand dust cap B
- (B) Chain guard
- (C) Right hand dust cap
- (D) Driver

2

Install the CS-S500 sprocket to the driver on the right side of the hub body with the guard plate facing outward, and secure it in place with the snap ring.

- (A) Driver
- (B) Snap ring
- (C) Guard plate
- (D) CS-S500 Sprocket



Click here for the latest Dealer's Manual

<https://si.shimano.com/DM/SG0004>

## Installation of the cassette joint to the hub

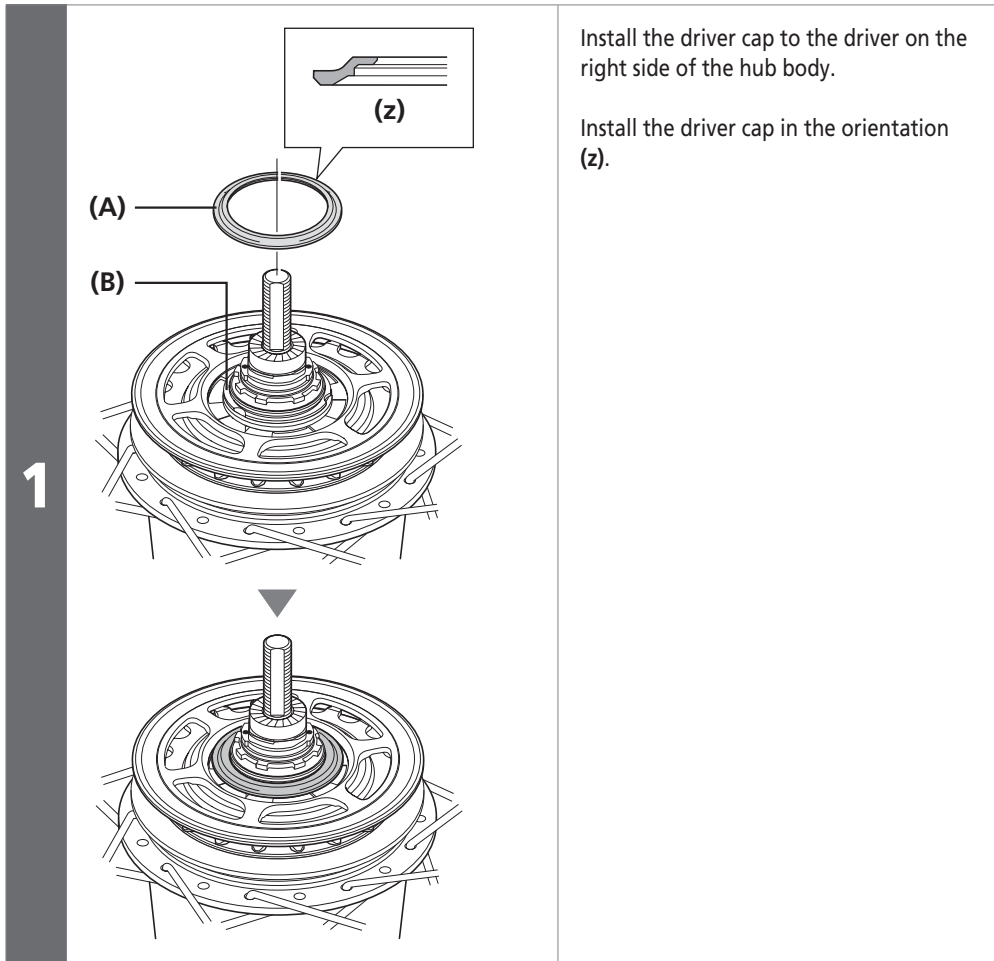

Install the driver cap to the driver on the right side of the hub body.

Install the driver cap in the orientation (z).

- (A) Driver cap
- (B) Driver



Dealer's Manual (SG-S7001-11)

2

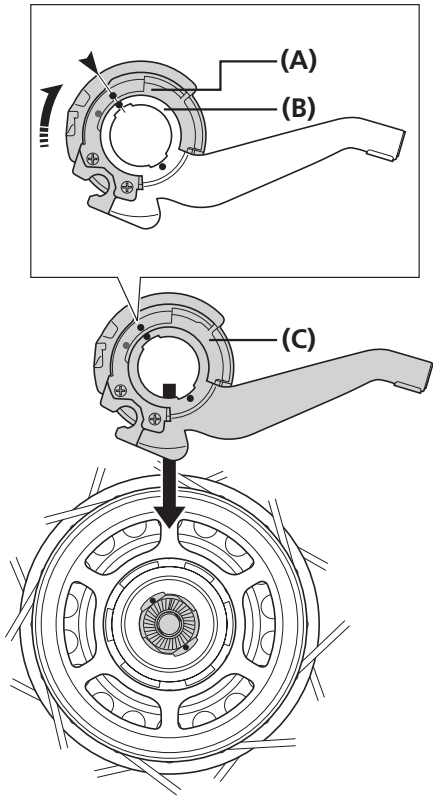

Turn the cassette joint pulley in the direction of the arrow in the illustration to align the red ● marks on the pulley and the bracket. With the cassette joint in this condition, install it so that the red ● mark on the cassette joint is aligned with the red ● mark on the right side of the hub body.

- (A) Pulley
- (B) Bracket
- (C) Cassette joint

3

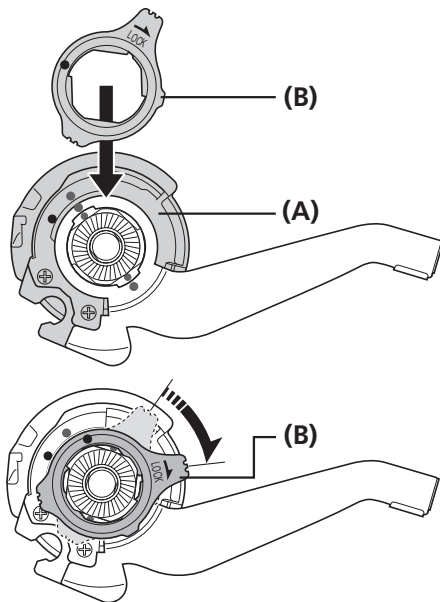

Secure the cassette joint to the hub with the cassette joint fixing ring.

When installing the cassette joint fixing ring, align the yellow ● mark with the yellow ● mark on the cassette joint pulley, and then turn the cassette joint fixing ring 45° clockwise.

- (A) Pulley
- (B) Cassette joint fixing ring



## Installation of the disc brake rotor

Install the disc brake rotor as shown in the illustration.

SG-S7001-8

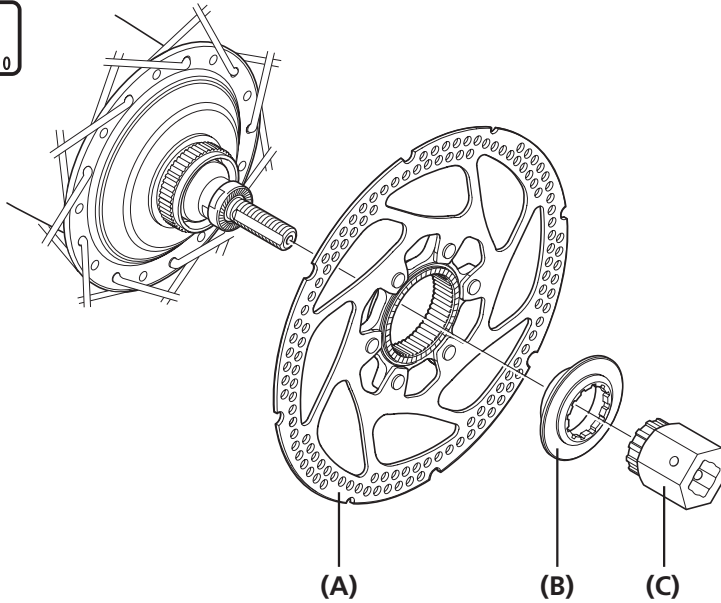

- (A) Disc brake rotor
- (B) Disc brake rotor installation ring
- (C) TL-LR10

### Tightening torque



40 N·m



SG-S7001-11

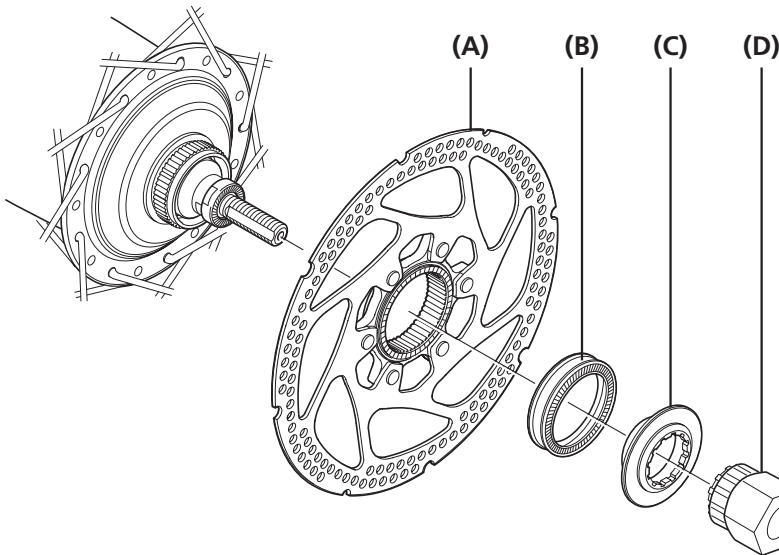

- (A) Disc brake rotor
- (B) Rotor spacer
- (C) Disc brake rotor installation ring
- (D) TL-LR10

### Tightening torque



40 N·m



Click here for the latest Dealer's Manual

<https://si.shimano.com/DM/SG0004>

## Installation of the hub to the frame

1

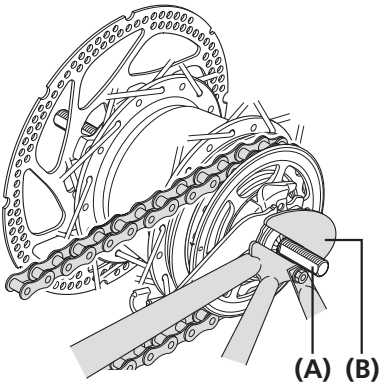

**When not using the chain tensioner**  
Mount the chain on the sprocket, then set the hub axle into the rear dropout.

- (A) Hub axle
- (B) Rear dropout
- (C) Chain tensioner

### NOTICE

When using the chain tensioner, be sure to read these instructions in conjunction with the instructions for the CT-S500 chain tensioner.

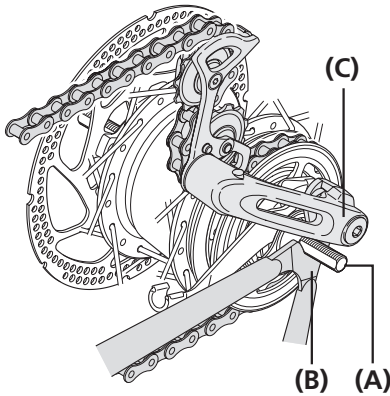

**When using the chain tensioner**  
Mount the chain on the sprocket, then set the hub axle into the rear dropout.

2

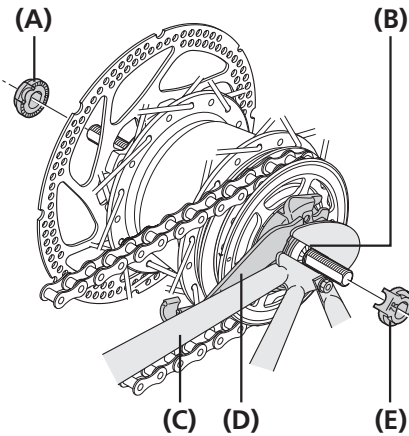

Place the non-turn washers onto the right side and left side of the hub axle.

At this time, turn the cassette joint so that the protrusions of the non-turn washers fit into the grooves in the rear dropout and align the joint to be almost parallel to the chainstay.

- (A) Non-turn washer (for left side)
- (B) Rear dropout groove
- (C) Chainstay
- (D) Cassette joint
- (E) Non-turn washer (for right side)

### TECH TIPS

- Use a non-turn washer that matches the shape of the rear dropout. Different non-turn washers are used for the left and right sides.
- The protrusion should be on the rear dropout side.
- Install the non-turn washer so that the protrusion fits securely in the rear dropout groove at the front and back sides of the hub axle.



Rear dropout	Non-turn washer		
	Mark / Color		Size
	Right	Left	
Standard	5R/Yellow	5L/Brown	$\theta \leq 20^\circ$
	7R/Black	7L/Gray	$20^\circ \leq \theta \leq 38^\circ$
	9R/Light green	9L/Light brown	
Reversed	6R/Silver	6L/White	$\theta = 0^\circ$
Reversed (full chain case)	5R/Yellow	5L/Brown	$\theta = 0^\circ$
Vertical	8R/Blue	8L/Green	$\theta = 60^\circ - 90^\circ$



Click here for the latest Dealer's Manual

<https://si.shimano.com/DM/SG0004>

Dealer's Manual (SG-S7001-11)

3



(A) (B)

Take up the slack in the chain and secure the wheel to the frame with the cap nuts.

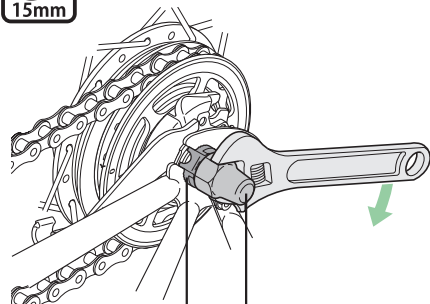

(A) (C) (D)  
(E) (B)

When installing a part such as a mudguard stay to the hub axle, install in the order shown in the illustration.

- (A) Non-turn washer
- (B) Cap nut
- (C) Carrier stay
- (D) Washer
- (E) Mudguard stay

Tightening torque	
	30 - 45 N·m

NOTICE

When installing the hub to the frame, the chain guard may come off, so check that the chain guard is securely installed so that it will not come off. If it is not fully installed, noise may be generated.

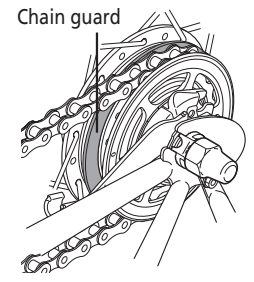

## ■ Installing the shifter

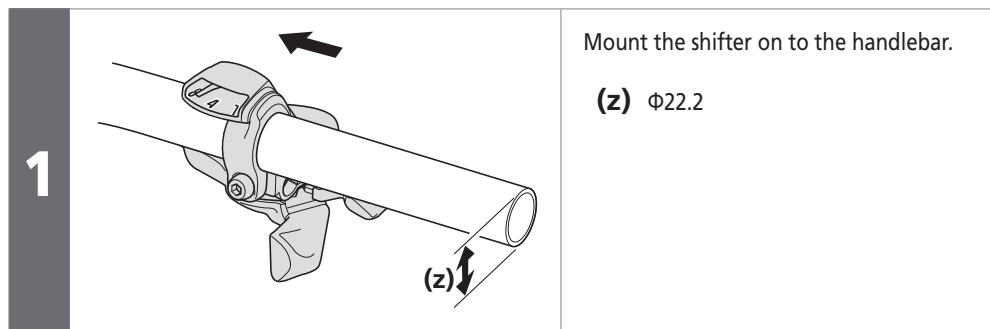

Mount the shifter on to the handlebar.

(z)  $\Phi 22.2$

### NOTICE

Use a handlebar with an outer diameter of  $\Phi 22.2$  mm.

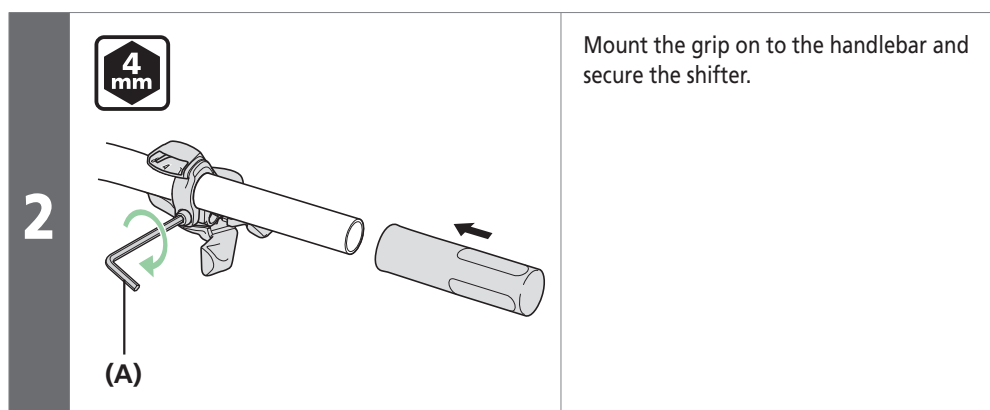

Mount the grip on to the handlebar and secure the shifter.

(A) 4 mm hexagon wrench

### Tightening torque



5 - 7 N·m

### NOTICE

Use a handlebar grip with a maximum outer diameter of  $\Phi 32$  mm.

## ■ Installation of the shifting cable

For internal 8-speed

### Shifter side

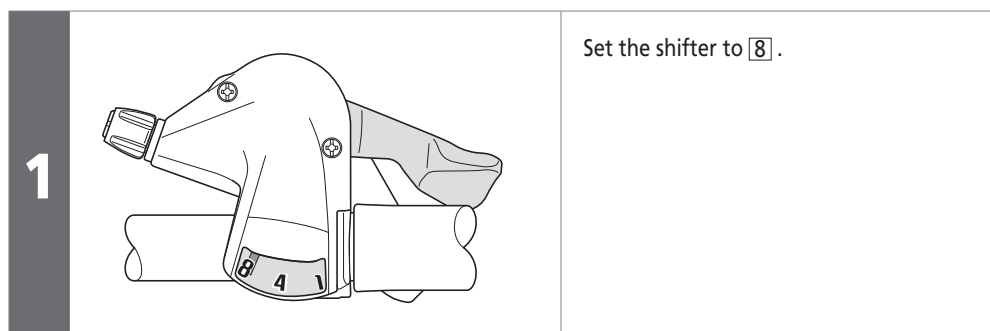

Set the shifter to **8**.

### NOTICE

- Use a shifting cable with one inner cable drum.  
Cable with one inner cable drum: OT-SP41



- Make sure that the sealed outer cap is at the shifter end.



Click here for the latest Dealer's Manual

<https://si.shimano.com/DM/SG0004>

Dealer's Manual (SG-S7001-11)

**2**

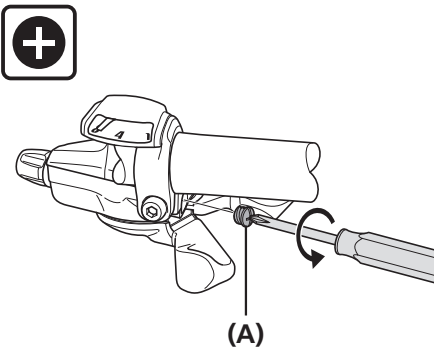

Loosen and remove the inner hole cap.

(A) Inner hole cap

**3**

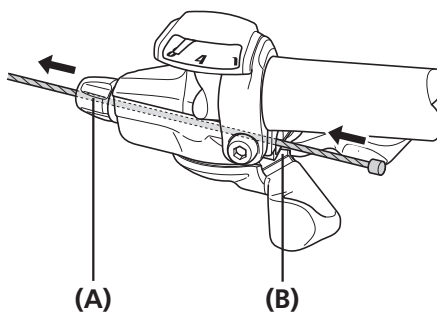

Insert the inner cable into the winder unit cable fixing groove, then pass it through the hole in the cable adjustment barrel.

(A) Hole in cable adjustment barrel  
(B) Winder unit cable fixing groove

**4**

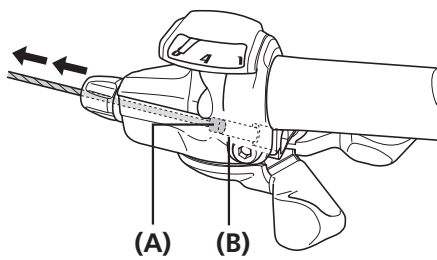

Pull the inner cable so that the inner cable drum fits into the hole in the winder unit.

(A) Inner cable drum  
(B) Hole in winder unit

**5**

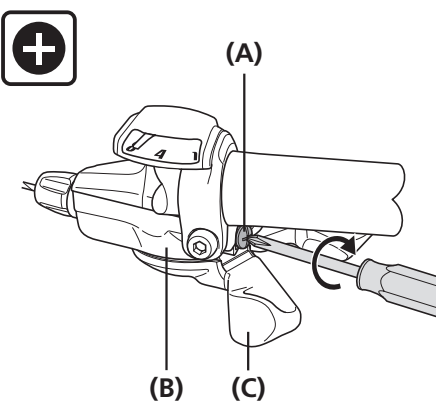

Screw in the inner hole cap as shown in the illustration until it stops.

If it is turned any further, it will damage the screw thread in the cover.

In addition, the unit cover may become bent, which may cause an obstruction between the unit cover and the main lever, and the main lever may not operate correctly.

If the main lever does not return properly, loosen the inner hole cap slightly to make a gap between the main lever and the unit cover, and check that this improves the returning of the main lever.

(A) Inner hole cap  
(B) Unit cover  
(C) Main lever



6

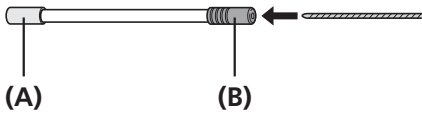

Pass the inner cable through the OT-SP41 outer casing through the end with the plastic cap.

- (A) Aluminum cap
- (B) Plastic cap

 TECH TIPS

If cutting the outer casing, cut it near the end with the plastic cap while the cap is still attached.

Then make the cut end perfectly round and attach the plastic cap.

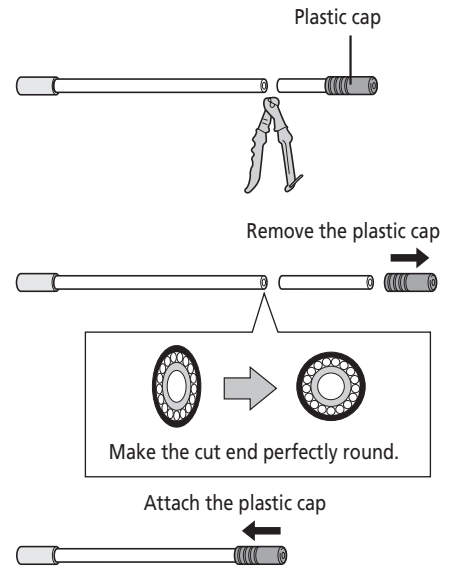

Click here for the latest Dealer's Manual

<https://si.shimano.com/DM/SG0004>

Cassette joint end

**1**

TL-S700-B



**(A)**

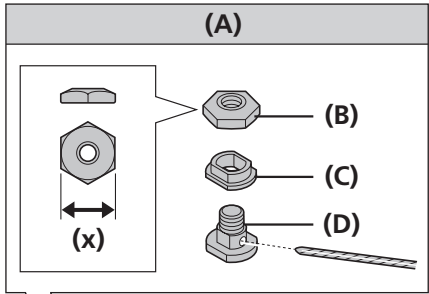

After checking that the end of the outer casing is sitting securely in the cable adjustment barrel of the shifter, attach the inner cable fixing bolt unit to the inner cable.

Then, pull the inner cable while attaching the inner cable fixing bolt unit.

**(x)** 10 mm  
**(y)** 145 mm  
**(z)** 63 mm or less

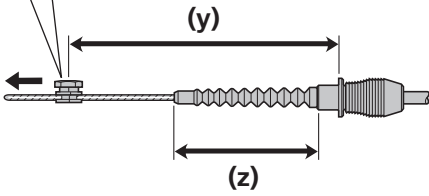

- (A)** Inner cable fixing bolt unit
- (B)** Inner cable mounting nut
- (C)** Inner cable fixing washer
- (D)** Inner cable fixing bolt

Tightening torque	
	3.5 - 5.5 N·m

**NOTICE**

Do not use this inner cable fixing bolt unit with the CJ-4S30 cassette joint.

**TECH TIPS**

When installing the inner cable fixing bolt unit, use the setting tool TL-S700-B.

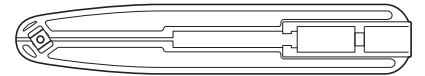

**2**

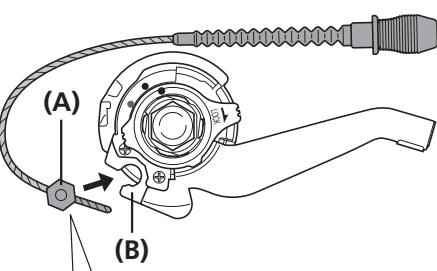

Bring the cable around to the cassette joint pulley, hold it so that the inner cable mounting nut is facing outwards (towards the rear dropout), then slide the flats part (z) of the inner fixing washer into the notch (y) in the pulley.

- (A)** Inner cable mounting nut
- (B)** Pulley



Click here for the latest Dealer's Manual

<https://si.shimano.com/DM/SG0004>

Dealer's Manual (SG-S7001-11)

**3**

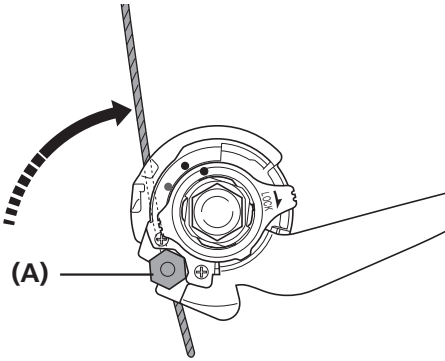

Turn the cable 60° counterclockwise and attach it to the hook.

(A) Hook

**4**

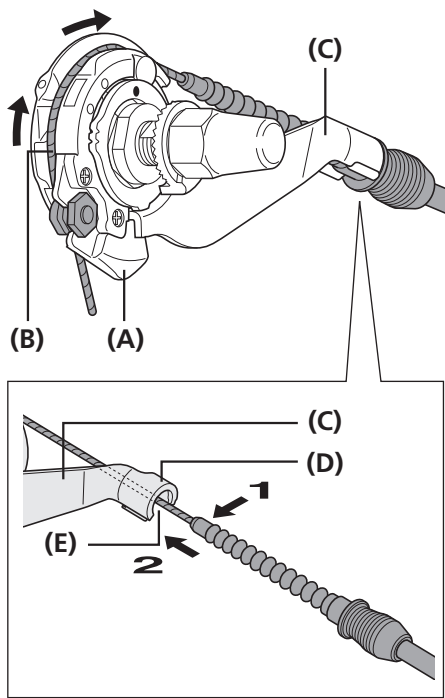

Set the inner cable in the pulley as shown in the figure and, while holding the rubber cover, insert the rubber bellows of the inner cable into the slit in the cassette joint bracket (y) and securely set the outer casing holder body into the outer casing holder section of the cassette joint (z).

(A) Pulley  
(B) Inner cable  
(C) Bracket  
(D) Outer casing holder section  
(E) Slit

**NOTICE**

Check that the inner cable is correctly seated inside the pulley guide.

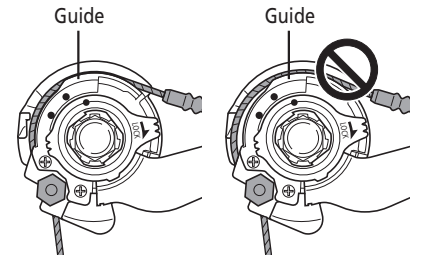

**5**

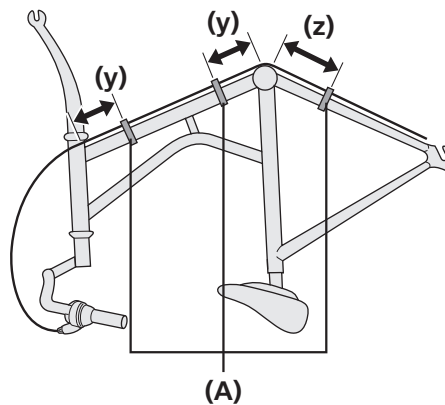

Secure the cable to the frame with the outer casing bands.

(y) 10 cm  
(z) 15 cm

(A) Outer casing bands



Click here for the latest Dealer's Manual

<https://si.shimano.com/DM/SG0004>

Disconnecting the shifting cable when removing the rear wheel from the frame

**1**

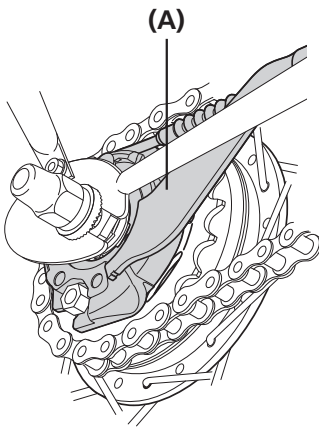

(A)

Disconnect the cable from the cassette joint when removing the rear wheel from the frame.

(A) Cassette joint

**1**

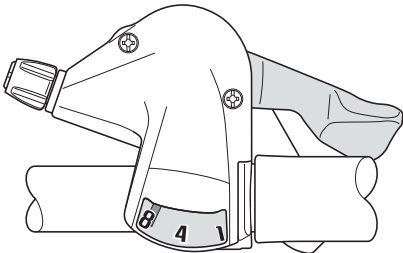

Set the shifter to 8.

**2**

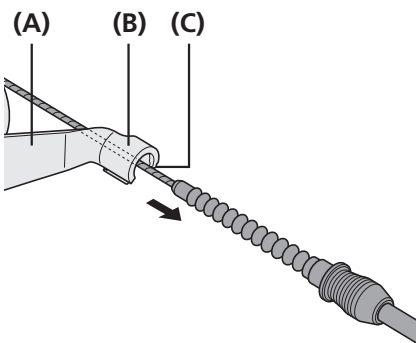

(A) (B) (C)

Pull out the outer casing from the outer casing holder section of the cassette joint, and remove the inner cable from the slit in the bracket.

(A) Bracket  
(B) Outer casing holder section  
(C) Slit

**3**

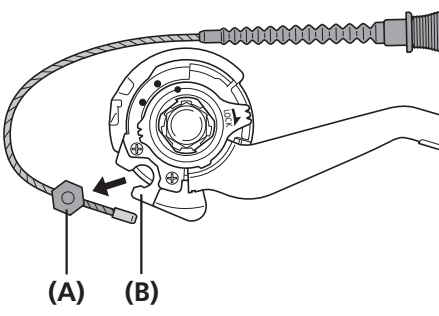

(A) (B)

Remove the inner cable fixing bolt unit from the cassette joint pulley.

(A) Inner cable fixing bolt unit  
(B) Cassette joint pulley

**NOTICE**

If reinstalling the cable, refer to steps 2 to 4 in "Cassette joint end".



For internal 11-speed

Shifter side

1

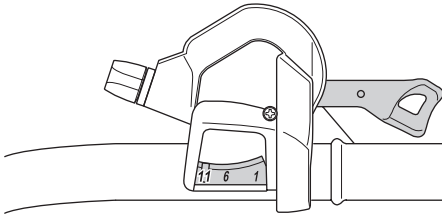

Set the shifter to **11**.

**NOTICE**

- Use a shifting cable with one inner cable drum.  
Cable with one inner cable drum: OT-SP41

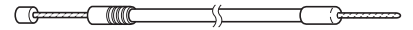

- Make sure that the sealed outer cap is at the shifter end.

2

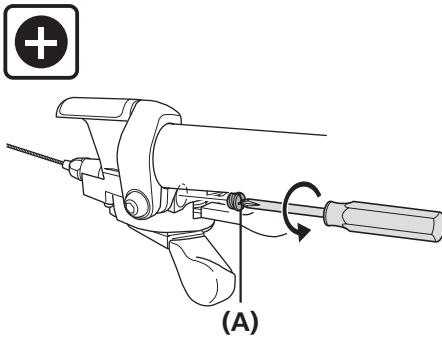

Loosen and remove the inner hole cap.

**(A)** Wire end hooking cap

3

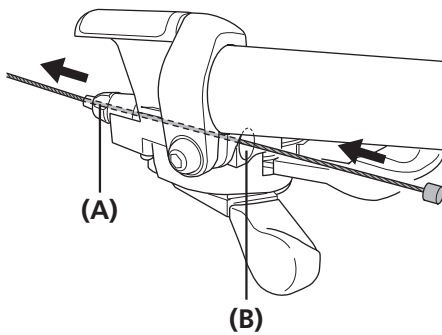

Insert the inner cable into the hole in the winder unit, and then pass it through the hole in the cable adjustment barrel.

**(A)** Hole in cable adjustment barrel  
**(B)** Hole in winder unit

4

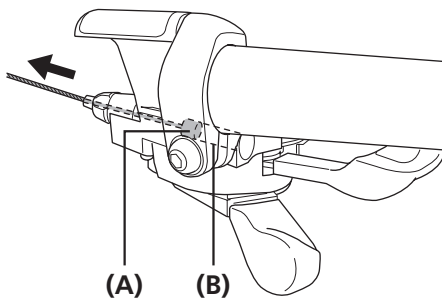

Pull the inner cable so that the inner cable drum fits into the hole in the winder unit.

**(A)** Inner cable drum  
**(B)** Hole in winder unit



Dealer's Manual (SG-S7001-11)

5

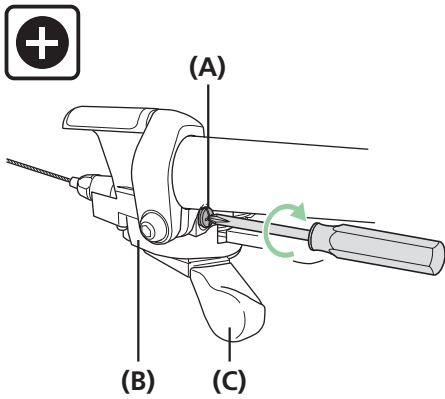

Screw in the inner hole cap as shown in the illustration until it stops.

If it is turned any further, it will damage the screw thread in the cover.

In addition, the unit cover may become bent, which may cause an obstruction between the unit cover and the main lever, and the main lever may not operate correctly.

If the main lever does not return properly, loosen the inner hole cap slightly to make a gap between the main lever and the unit cover, and check that this improves the returning of the main lever.

- (A) Inner hole cap
- (B) Unit cover
- (C) Main lever

Tightening torque

+	0.3 - 0.5 N·m
---	---------------

6

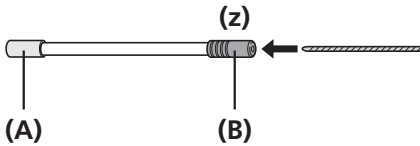

Pass the inner cable through the OT-SP41 outer casing through the end with the plastic cap.

(z) Lever side

- (A) Aluminum cap
- (B) Plastic cap

TECH TIPS

If cutting the outer casing, cut it near the end with the plastic cap while the cap is still attached. Then make the cut end perfectly round and attach the plastic cap.

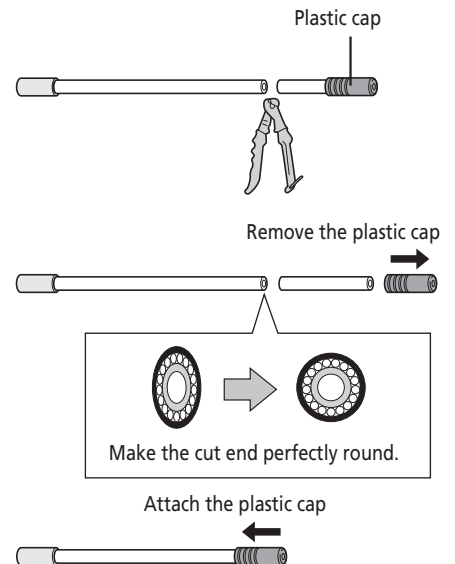

Click here for the latest Dealer's Manual

<https://si.shimano.com/DM/SG0004>

Cassette joint end

1

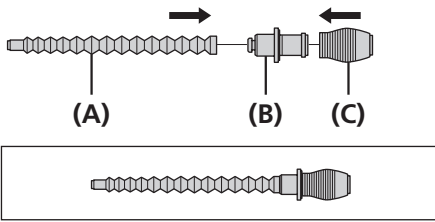

Install the rubber cover and rubber bellows to the outer casing holder body.

- (A) Rubber bellows
- (B) Outer casing holder body
- (C) Rubber cover

2

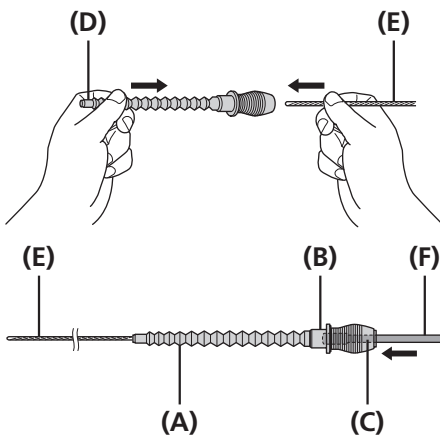

Wipe away any grease which may be on the inner cable and, while holding the end of the rubber bellows, pass the inner cable through. Be careful not to pierce the rubber bellows with the end of the inner cable at this time.

Slide the rubber bellows onto the inner cable.

After this, insert the outer casing into the rubber cover and set it into the outer casing holder body. Push the outer casing so that it securely touches the holder body.

- (A) Rubber bellows
- (B) Outer casing holder body
- (C) Rubber cover
- (D) End of rubber bellows
- (E) Inner cable
- (F) Outer casing

NOTICE

Use a new inner cable. Do not use a cable which has had the end cut off. Pay attention to the end of the inner cable.



Click here for the latest Dealer's Manual

<https://si.shimano.com/DM/SG0004>

**3**

TL-S700-B  
10mm

(A)

(B)

(C)

(D)

(x)

(y)

(z)

After checking that the end of the outer casing is sitting securely in the cable adjustment barrel of the shifter, attach the inner cable fixing bolt unit to the inner cable.

Then, pull the inner cable while attaching the inner cable fixing bolt unit.

(x) 10 mm  
(y) 184 mm  
(z) 75 mm or less

- (A) Inner cable fixing bolt unit
- (B) Inner cable mounting nut
- (C) Inner cable fixing washer (Black)
- (D) Inner cable fixing bolt (Black)

Tightening torque	
	3.5 - 5.5 N·m

**NOTICE**

This inner cable fixing bolt unit is designed only for CJ-S700. 7-step and 8-step fixing bolt units cannot be used.

**TECH TIPS**

When installing the inner cable fixing bolt unit, use the setting tool TL-S700-B.

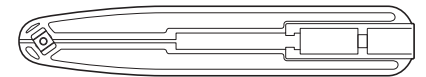

**4**

(A)

Turn the lever of the pulley clockwise. In the following steps 5 and 7, continue to work in this condition.

- (A) Pulley lever

**5**

(A)

(B)

(z)

(y)

Bring the cable around to the cassette joint pulley, hold it so that the inner cable mounting nut is facing outwards (towards the rear dropout), then slide the flats part (z) of the inner fixing washer into the notch (y) in the pulley.

- (A) Inner cable mounting nut
- (B) Pulley



Dealer's Manual (SG-S7001-11)

6

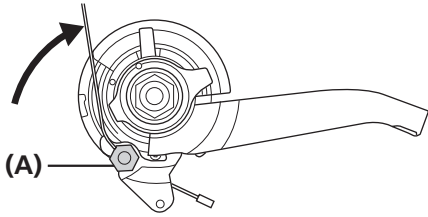

Turn the cable 60° counterclockwise and attach it to the hook.

(A) Hook

7

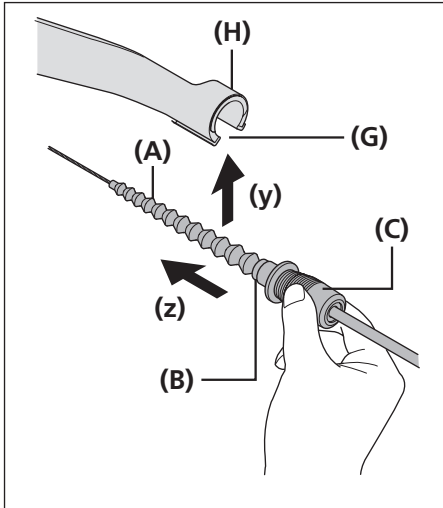

Set the inner cable in the pulley as shown in the figure and, while holding the rubber cover, insert the rubber bellows of the inner cable into the slit in the cassette joint bracket (y) and securely set the outer casing holder body into the outer casing holder section of the cassette joint (z). Be careful not to damage the rubber bellows at this time.

- (A) Rubber bellows
- (B) Outer casing holder body
- (C) Rubber cover
- (D) Inner cable
- (E) Pulley
- (F) Bracket
- (G) Slit
- (H) Outer casing holder section

NOTICE

Check that the inner cable is correctly seated inside the pulley guide.

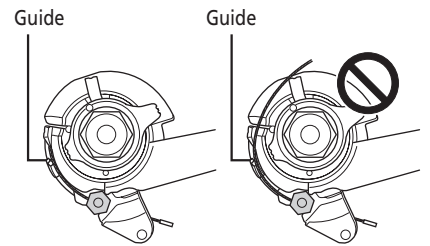

8

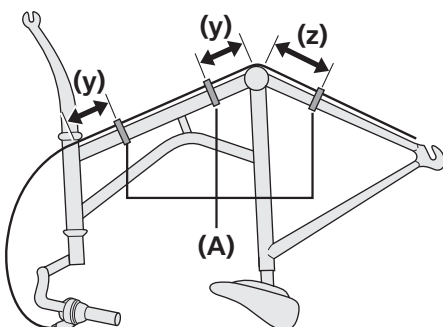

Secure the cable to the frame with the outer casing bands.

- (y) 10 cm
- (z) 15 cm

(A) Outer casing bands



Click here for the latest Dealer's Manual

<https://si.shimano.com/DM/SG0004>

Disconnecting the shifting cable when removing the rear wheel from the frame

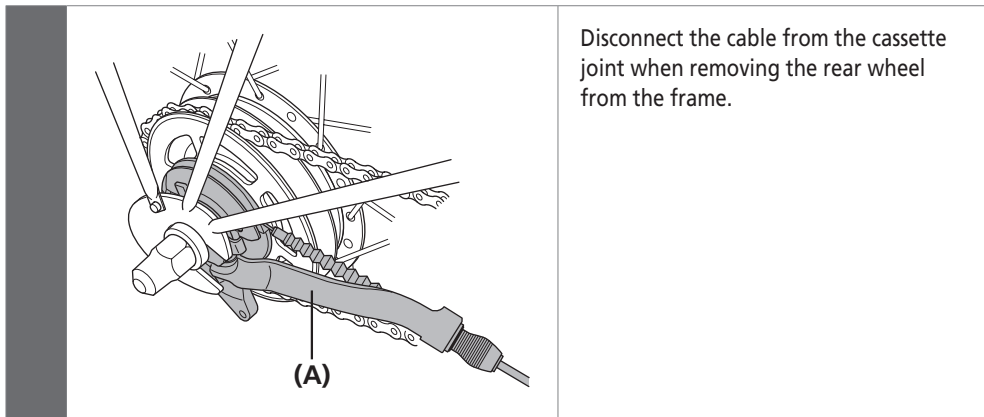

Disconnect the cable from the cassette joint when removing the rear wheel from the frame.

(A) Cassette joint

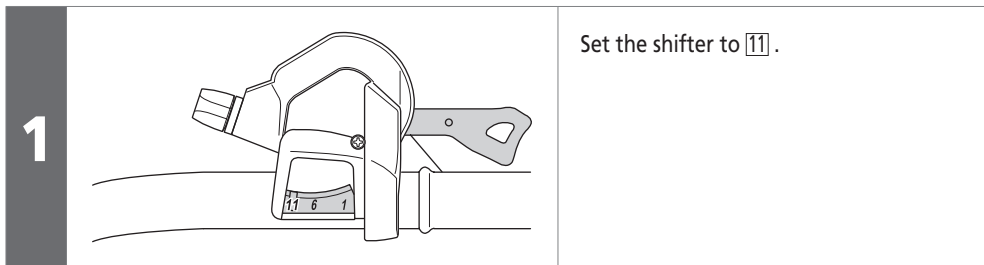

Set the shifter to 11.

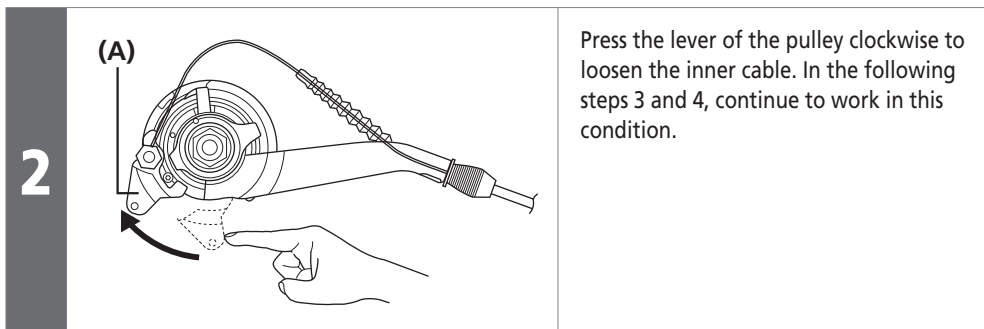

Press the lever of the pulley clockwise to loosen the inner cable. In the following steps 3 and 4, continue to work in this condition.

(A) Pulley lever

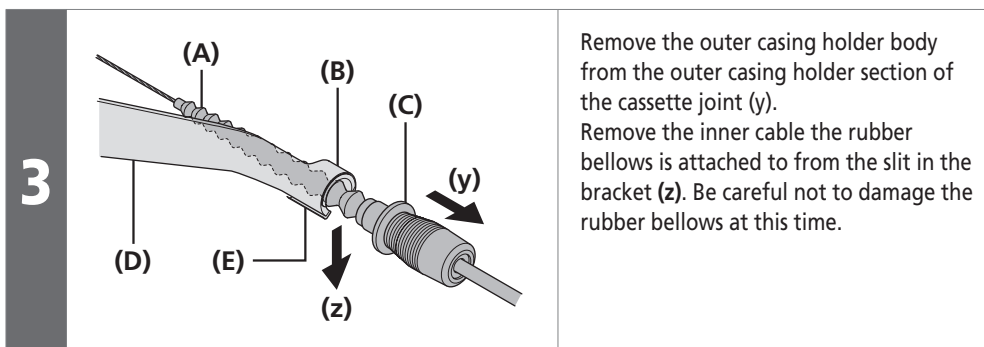

Remove the outer casing holder body from the outer casing holder section of the cassette joint (y). Remove the inner cable the rubber bellows is attached to from the slit in the bracket (z). Be careful not to damage the rubber bellows at this time.

(A) Rubber bellows  
(B) Outer casing holder section  
(C) Outer casing holder body  
(D) Bracket  
(E) Slit

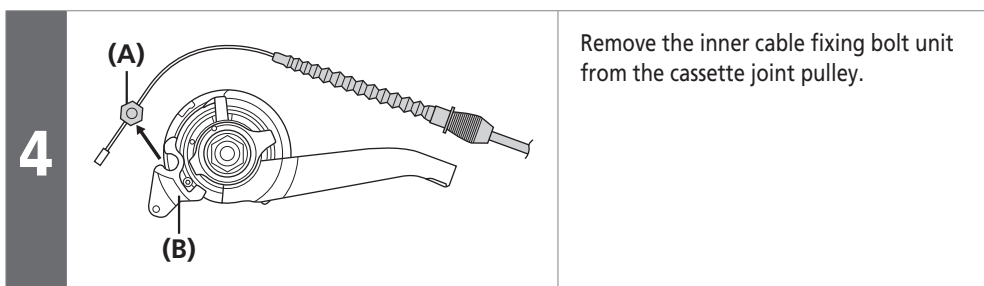

Remove the inner cable fixing bolt unit from the cassette joint pulley.

(A) Inner cable fixing bolt unit  
(B) Cassette joint pulley

NOTICE

If reinstalling the cable, refer to steps 4 to 7 in "Cassette joint end".



Click here for the latest Dealer's Manual

<https://si.shimano.com/DM/SG0004>

## ADJUSTMENT

### Adjusting the cassette joint

For internal 8-speed

1

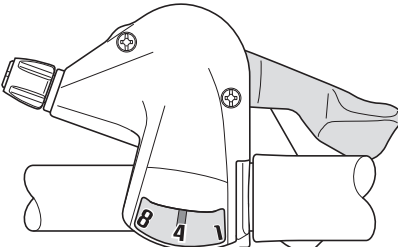
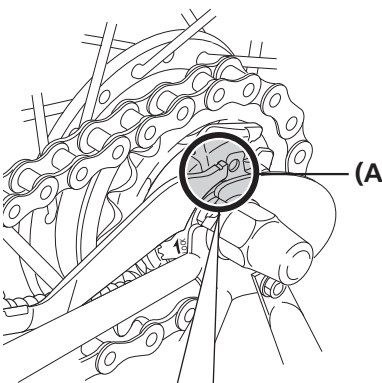
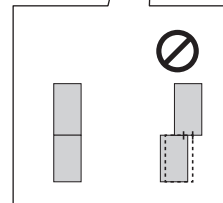
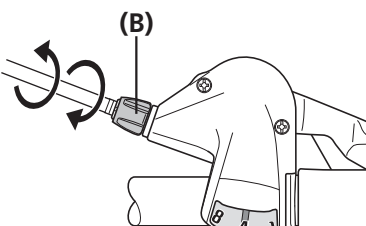
Set the shifter from **8** to **4**.

Check to be sure that the yellow setting lines on the cassette joint bracket and pulley are aligned at this time.

If the yellow setting lines are not aligned, turn the cable adjustment barrel of the shifter to align the setting lines.

After this, move the shifter again from **4** to **8** then back to **4**, and re-check that the yellow setting lines are aligned.

- (A)** Yellow setting lines
- (B)** Cable adjustment barrel

#### TECH TIPS

- The yellow setting lines on the cassette joint are located in two places. Use the one that is easiest to see.

< When bicycle is standing up >

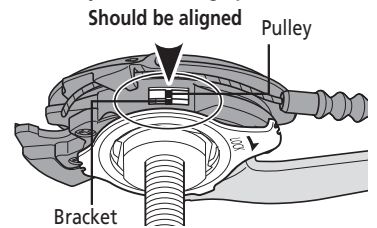

< When bicycle is upside down >

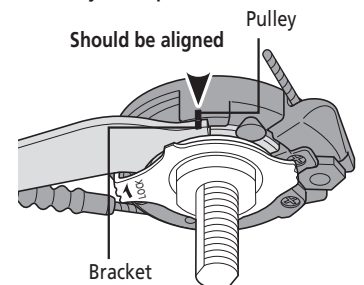

Click here for the latest Dealer's Manual

<https://si.shimano.com/DM/SG0004>

2

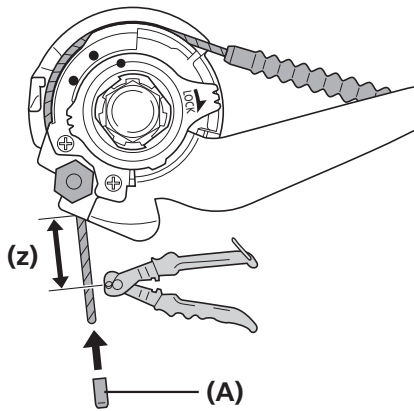

After adjusting the cassette joint, cut off the excess length of inner cable.

Then install the inner end cap.

**(z)** 15 - 20 mm

**(A)** Inner end cap



Click here for the latest Dealer's Manual

<https://si.shimano.com/DM/SG0004>

For internal 11-speed

**1**

Set the shifter from **11** to **6**.  
Check to be sure that the yellow setting lines on the cassette joint bracket and pulley are aligned at this time.

If the yellow setting lines are not aligned, turn the cable adjustment barrel of the shifter to align the yellow setting lines.

After this, move the shifter again from **6** to **11** then back to **6**, and re-check that the yellow setting lines are aligned.

- (A)** Yellow setting lines
- (B)** Cable adjustment barrel

**TECH TIPS**

- The yellow setting lines on the cassette joint are located in two places. Use the one that is easiest to see.

< When bicycle is standing up >  
Should be straight

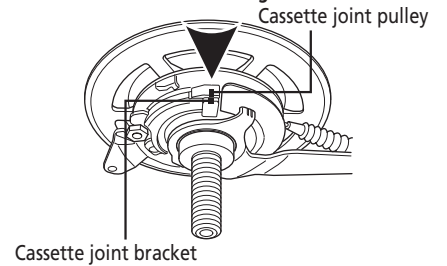

< When bicycle is upside down >  
Should be straight

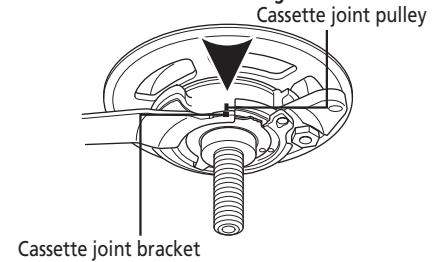

**2**

After adjusting the cassette joint, cut off the excess length of inner cable.

Then install the inner end cap.  
After installing the inner end cap, slightly bend the inner cable outward (towards the rear dropout) so that it does not touch the chain.

**(z)** 25 - 30 mm

- (A)** Inner end cap



## MAINTENANCE

### ■ Replacement and assembly of the indicator unit

Disassembly and assembly should only be carried out when removing and replacing the indicator unit.

For internal 8-speed

#### Removal

1

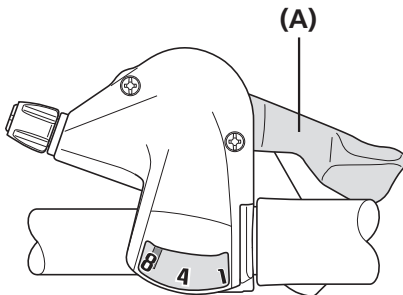

Operate the release lever 7 times or more to set it to **8**.

(A) Release lever

2

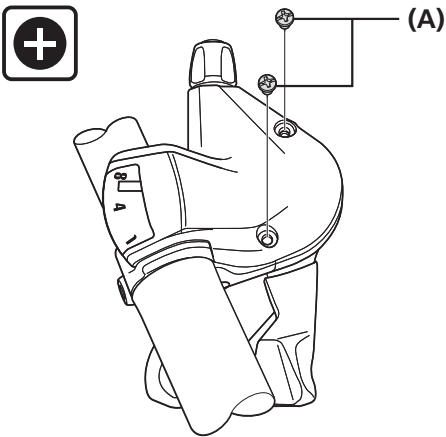

Loosen and remove the two cover fixing screws which are securing the indicator unit.

(A) Cover fixing screws



3

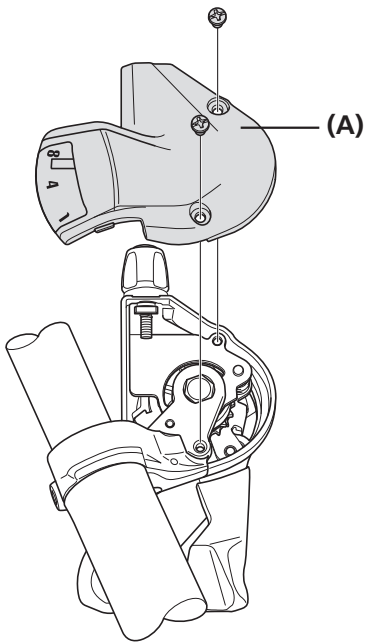

Remove the indicator unit as shown in the illustration.

(A) Indicator unit



Click here for the latest Dealer's Manual

<https://si.shimano.com/DM/SG0004>

## Installation

1

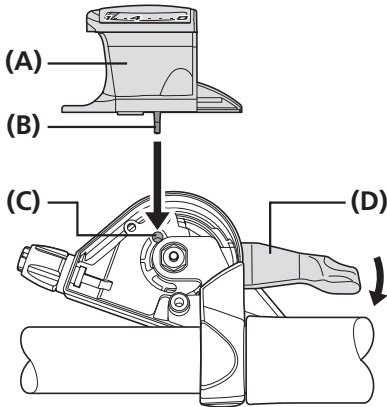

Check that the needle of the indicator is on the left side ([8] position), and then install the indicator unit so that it is facing straight upward.

Insert the pin of the change plate that is protruding from the bottom of the indicator unit into the hole in the winder unit at this time.

- (A) Indicator unit
- (B) Pin of change plate
- (C) Hole in winder unit ([8] position)
- (D) Release lever

2

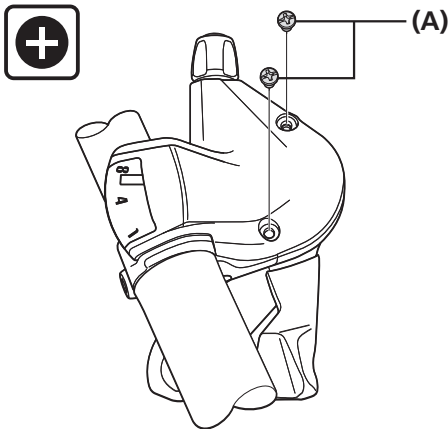

Secure the indicator unit with the two cover fixing screws.

- (A) Cover fixing screws

### Tightening torque



0.3 - 0.5 N·m

3

Operate the main and the release levers, to check their operation.

If they do not operate correctly, reinstall the indicator unit while taking particular note of step 1.



For internal 11-speed

Removal

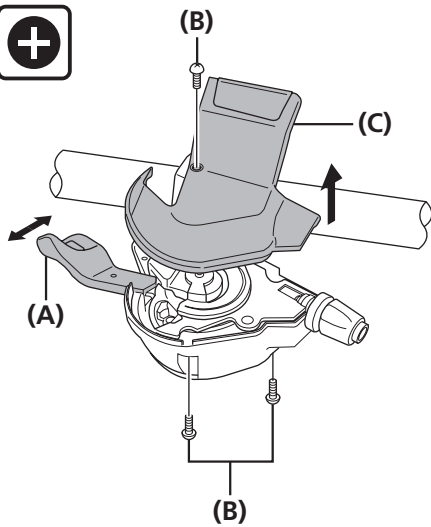

Operate the release lever 10 times or more to set it to **11**.

Loosen and remove the three cover fixing screws which are securing the indicator unit.

Remove the indicator unit as shown in the illustration.

- (A) Release lever
- (B) Cover fixing screws
- (C) Indicator unit

Installation

1

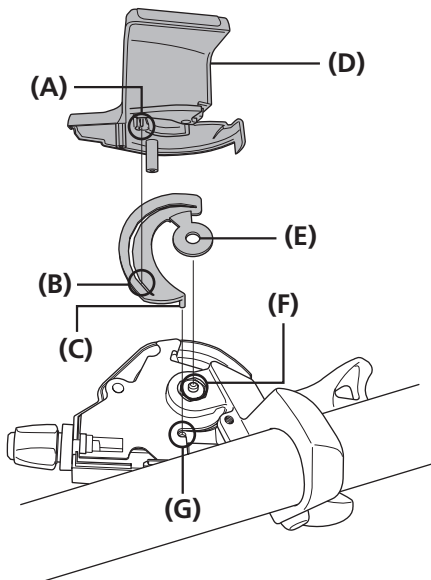

Check that the needle of the indicator is on the left side (**11** position), and then install the indicator unit so that it is facing straight upward.

At this time, check that the main axle is installed in the cam unit hole and that the pin of the cam unit is installed in the winder unit hole, and then insert the indicator shaft protruding from the bottom of the indicator unit into the groove of the cam unit.

- (A) Indicator shaft
- (B) Cam unit groove (**11** position)
- (C) Cam unit pin
- (D) Indicator unit
- (E) Cam unit hole
- (F) Main axle
- (G) Winder unit hole

2

Secure the indicator unit with the three cover fixing screws.

3

Operate the main and the release levers, to check their operation.

If they do not operate correctly, reinstall the indicator unit while taking particular note of step 1.

Tightening torque



0.3 - 0.5 N·m



Click here for the latest Dealer's Manual

<https://si.shimano.com/DM/SG0004>

## ■ For internal 8-speed (oil maintenance kit: Y00298010)

Content of kit: WB maintenance oil, container

### Important safety information

#### WARNING



- When lubricating the internal unit, be careful that no oil gets on the disc brake rotor, pads, on the rim when using rim brakes, etc. If oil gets on any of these parts, there is a danger that brake performance may be reduced. Take care of this problem according to the procedures in the brake instruction manual.
- Since there is a risk of explosion or fire, do not smoke, eat, or drink while using this oil. In addition, keep it away from ignition sources such as heat, sparks, open flames, or high temperatures and prevent it from catching fire due to static electricity sparks or other sparks.
- Use only outdoors or in a well-ventilated area. Inhalation of oil mist or vapors may cause nausea. Be careful to provide ventilation and use a respirator type mask. If mist or vapor is inhaled, go immediately to an area with fresh air. Cover up with a blanket. Stay warm and stable and seek professional medical advice.

#### Cautions regarding handling of WB maintenance oil:

- Use appropriate eye protection when handling, and avoid contact with eyes. In the event of eye contact, flush with fresh water and seek medical assistance immediately. Contact with eyes may result in irritation.
- Use gloves when handling. In the event of skin contact, wash well with soapy water. Contact with skin may cause a rash and discomfort.
- Do not drink. If it is drunk by mistake, do not induce vomiting; make the affected person drink 1 to 2 cups of water and seek medical assistance immediately. If the affected person loses consciousness, do not give the person anything by their mouth. If vomiting occurs naturally, tilt the body to prevent inhalation.
- After use, be sure to wash hands thoroughly.
- Keep the container sealed to prevent foreign objects and moisture from getting inside, and store it in a cool, dark area away from direct sunlight.
- Keep out of reach of children.
- Dispose of used oil, old oil, or oil used for cleaning in accordance with the method stipulated by the law.
- In order to maintain proper performance, it is recommended that you lubricate the internal unit once a year from the start of use (or once about every 2,000 km if the bicycle is used very frequently).
- Do not use oil other than WB maintenance oil. Problems such as an oil leakage and gear shifting malfunction may occur.
- Disposal of used oil: Follow local county and/or state codes for disposal. Use caution when preparing the oil for disposal.
- Read this manual carefully, and keep it in a safe place for later reference.
- For the latest product safety data sheets, check the website <https://si.shimano.com>.

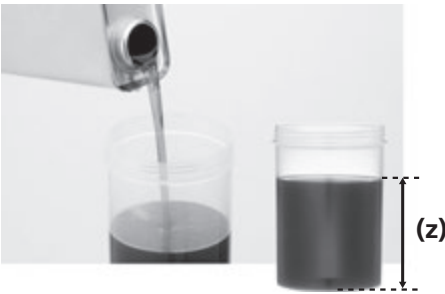

Dealer's Manual (SG-S7001-11)

<p>1</p>		<p>Fill the bottle with WB oil to a height of 95 mm.</p> <p><b>(z)</b> 95 mm</p>
<p>2</p>		<p>Immerse the internal unit into the oil from the left side. Immerse until the oil reaches up to ring gear unit 1.</p> <p><b>(z)</b> Ring gear unit 1</p>
<p>3</p>		<p>Keep the internal unit immersed as illustrated for approximately 90 seconds.</p>



Dealer's Manual (SG-S7001-11)

**4**



Remove the internal unit from the oil.

**5**



Let the excess oil drain off for approximately 60 seconds.

 **TECH TIPS**

<Maintenance oil>

- The maintenance oil is reusable. Refill it as needed.
- Store it with the lid closed after use.

**NOTICE**

After oil maintenance, it is recommended that you apply Grease (Y04130100) to the ball retainers, snap ring, brake shoe, and pinion gears.

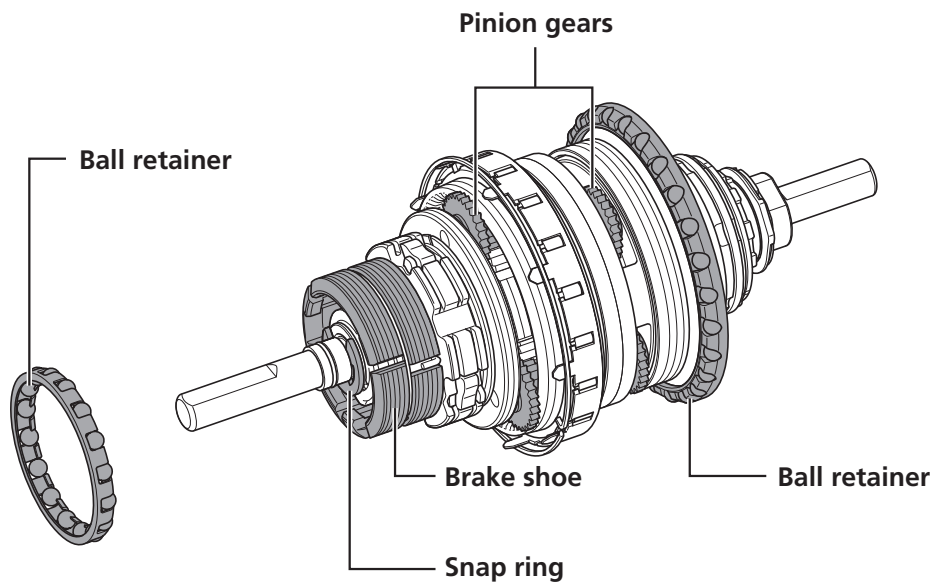

The illustration shows an example.



Click here for the latest Dealer's Manual  
<https://si.shimano.com/DM/SG0004>

Reassemble the hub.

- (1) Use the left-hand cone (or the stop nut for the coaster brake type) to adjust the hub so that the hub shell rotates smoothly and there is no excess play in the hub axle. Ensure that the side of the stop nut without a protrusion is facing up.
- (2) Tighten the left-hand lock nut. The tightening torque of the left-hand lock nut depends on the type.
  - For the disc brake, roller brake, or V brake type: 24.5 to 29.4 N·m
  - For the coaster brake or coaster brake (with disc brake) type: 17.7 to 24.5 N·m

In the case of roller brake type

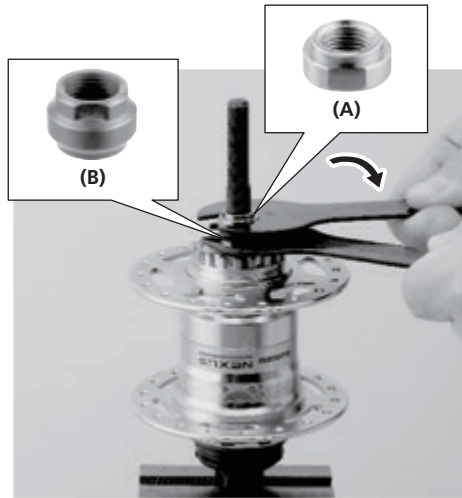

The image shows an example.

- (A) Left-hand lock nut
- (B) Left-hand cone

6

In the case of coaster brake type

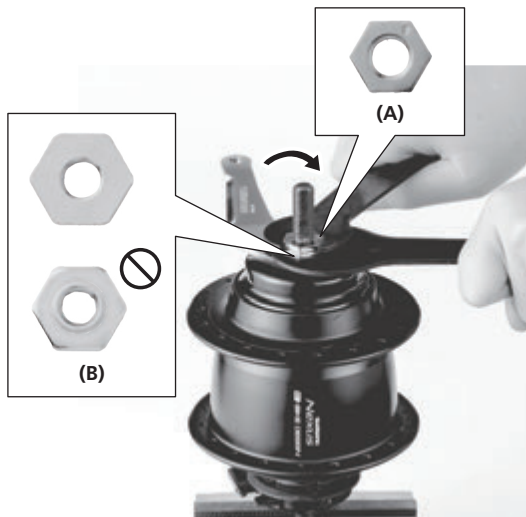

The image shows an example.

- (A) Left-hand lock nut
- (B) Stop nut



Click here for the latest Dealer's Manual

<https://si.shimano.com/DM/SG0004>

## ■ For internal 11-speed (oil maintenance kit: Y13098023)

Content of kit: syringe, tube, bleed nipple, O-ring, container

### Important safety information

#### WARNING

- When replacing the oil, be careful that no oil gets on the disc brake rotor, pads, on the rim when using rim brakes, etc. If oil gets on any of these parts, there is a danger that brake performance may be reduced. Take care of this problem according to the procedures in the brake instruction manual.
- Since there is a risk of explosion or fire, do not smoke, eat, or drink while using this oil. In addition, keep it away from ignition sources such as heat, sparks, open flames, or high temperatures and prevent it from catching fire due to static electricity sparks or other sparks.
- Use only outdoors or in a well-ventilated area. Inhalation of oil mist or vapors may cause nausea. Be careful to provide ventilation and use a respirator type mask. If mist or vapor is inhaled, go immediately to an area with fresh air. Cover up with a blanket. Stay warm and stable and seek professional medical advice.

#### Cautions regarding handling of SG-S700 OIL:

- Use appropriate eye protection when handling, and avoid contact with eyes. In the event of eye contact, flush with fresh water and seek medical assistance immediately. Contact with eyes may result in irritation.
- Use gloves when handling. In the event of skin contact, wash well with soapy water. Contact with skin may cause a rash and discomfort.
- Do not drink. If it is drunk by mistake, do not induce vomiting; make the affected person drink 1 to 2 cups of water and seek medical assistance immediately. If the affected person loses consciousness, do not give the person anything by their mouth. If vomiting occurs naturally, tilt the body to prevent inhalation.
- After use, be sure to wash hands thoroughly.
- Keep the container sealed to prevent foreign objects and moisture from getting inside, and store it in a cool, dark area away from direct sunlight.
- Keep out of reach of children.
- Disposal of used oil, old oil, or oil used for cleaning in accordance with the method stipulated by the law.
- In order to maintain proper performance, it is recommended that you replace the oil once a year from the start of use (or once about every 2,000 km if the bicycle is used very frequently).
- Do not use oil other than SG-S700 OIL. Problems such as an oil leakage and gear shifting malfunction may occur.
- Disposal of used oil: Follow local county and/or state codes for disposal. Use caution when preparing the oil for disposal.
- Read this manual carefully, and keep it in a safe place for later reference.
- For the latest product safety data sheets, check the website <https://si.shimano.com>.

#### TECH TIPS

When using a 1L can of oil, it may become impossible to suck out oil with a syringe when there is only a little oil left. First, transfer all oil to a different container.



## Internal geared hub: Oil replacement

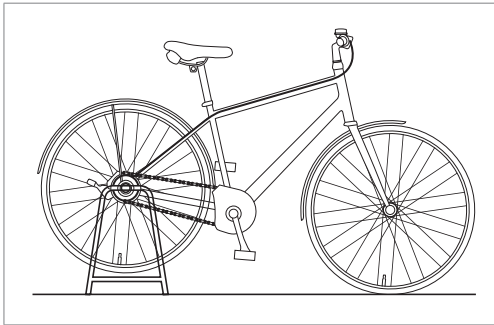

Using a stand, etc., enable the rear wheel to turn while performing work.

### Draining out the old oil

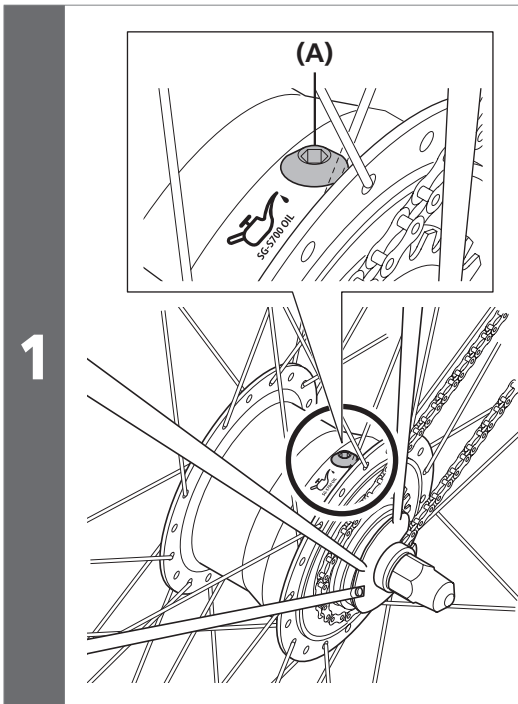

Rotate the wheel slowly until the oil port is facing up.

(A) Oil port

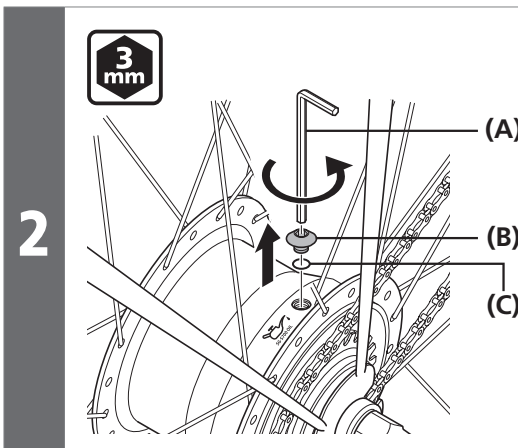

Remove the oil port screw and O-ring.

(A) 3 mm hexagon wrench

(B) Oil port screw

(C) O-ring

#### NOTICE

Be careful that the oil port is facing up; if the oil port screw is loosened when it is not facing up, the oil inside may leak out.



Click here for the latest Dealer's Manual

<https://si.shimano.com/DM/SG0004>

**3**

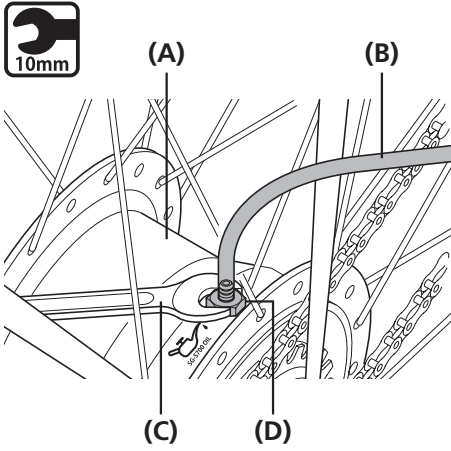

Attach the bleed nipple with tube attached to the hub shell.

- (A) Hub shell
- (B) Tube
- (C) 10 mm spanner
- (D) Bleed nipple

- (A) Hub shell
- (B) Tube
- (C) 10 mm spanner
- (D) Bleed nipple

Tightening torque	
	1 - 3 N·m

 **TECH TIPS**

Check that the O-ring is properly installed on the bleed nipple.

**4**

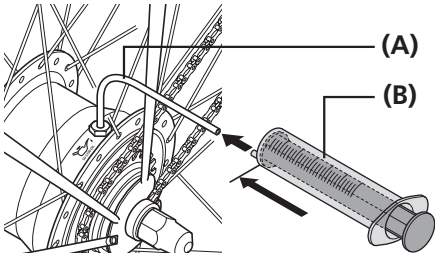

With the piston of the syringe pushed fully in, firmly connect the syringe to the tube.

- (A) Tube
- (B) Syringe

- (A) Tube
- (B) Syringe

**5**

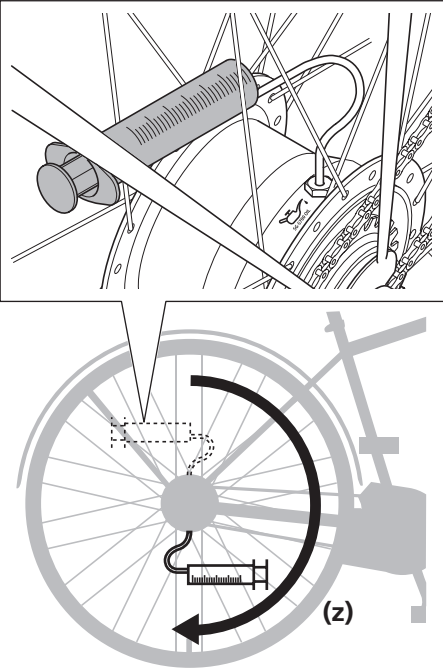

Insert the syringe between the spokes, and slowly turn the wheel forward until the oil port is facing down.

(z) Turn in forward direction

**6** Wait about 5 minutes with the hub kept still and not turning so that the oil settles.



Dealer's Manual (SG-S7001-11)

**7**

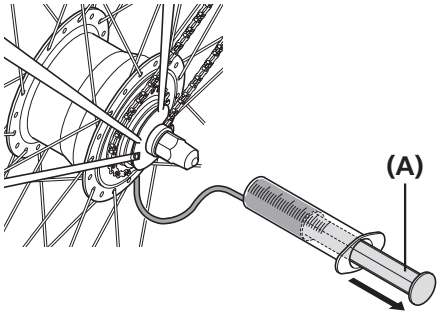

Pull the piston out slowly to draw out the oil inside the hub shell.

(A) Piston

**NOTICE**

If the piston is pulled out quickly, air is likely to be mixed in.

**8**

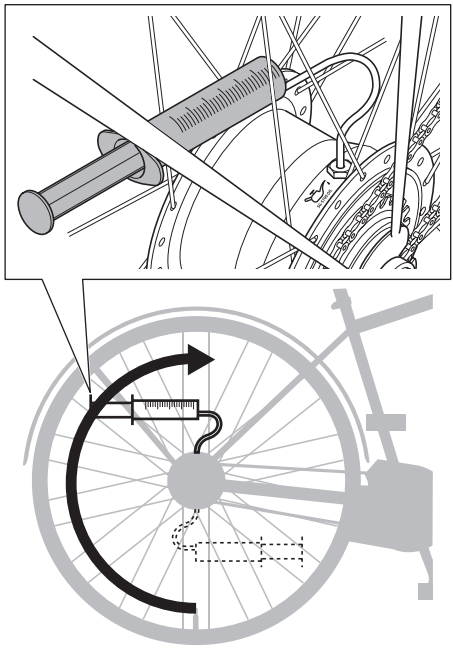

Rotate the wheel slowly until the oil port is facing up.

**NOTICE**

To make sure that the syringe does not get caught by the chain case, etc., store the syringe between the spokes when turning the wheel.

**9**

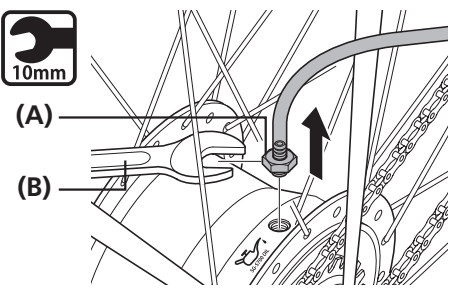

While being careful that the tube does not come off the syringe, remove the bleed nipple.

(A) Bleed nipple

(B) 10 mm spanner

**10**

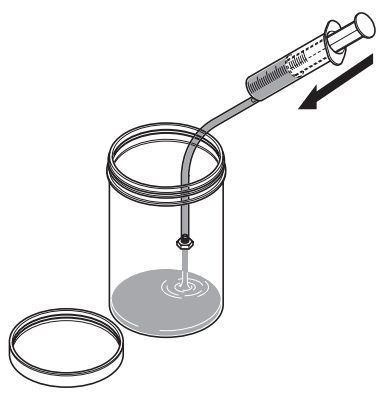

Remove the old oil from the syringe.



Click here for the latest Dealer's Manual

<https://si.shimano.com/DM/SG0004>

Cleaning the inside

1 Attach the bleed nipple to the hub shell.

1

2 Suck 25ml of new oil into the syringe and connect it firmly to the tube.

2

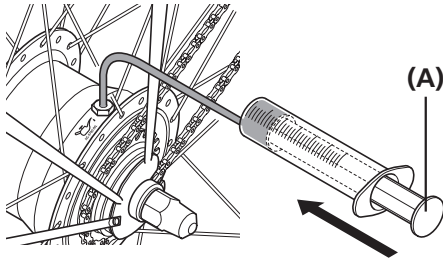

3 Push the piston to inject the new oil into the inside of the hub.

3

4 After pulling back the piston to reduce the internal pressure, remove the bleed nipple.

4

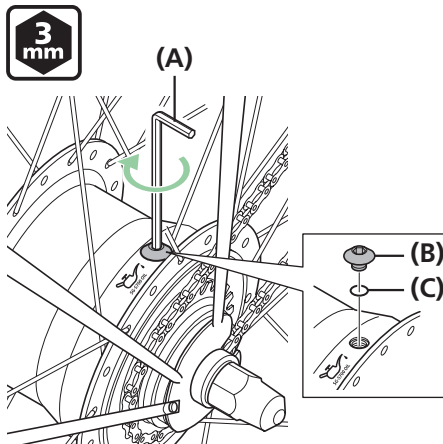

5 Install the O-ring and the oil port screw.

5

Tightening torque



1 - 3 N·m



TECH TIPS

If the syringe or tube becomes dirty when removing old oil or cleaning the inside of the hub, clean the syringe and tube using parts cleaner, etc., if necessary.

(A) Piston



TECH TIPS

When the oil is forced in, the internal pressure will increase and the piston may push back. If the piston is periodically pulled back to reduce the pressure inside the hub, the oil will be easier to inject into the inside of the hub.



TECH TIPS

If the bleed nipple is removed without pulling back the piston, the oil may flow back into the piston together with air from inside the tube and spill out of the piston.

- (A) 3 mm hexagon wrench
- (B) Oil port screw
- (C) O-ring

Tightening torque



2 - 3 N·m



Click here for the latest Dealer's Manual

<https://si.shimano.com/DM/SG0004>

Dealer's Manual (SG-S7001-11)

**6** While performing gear-change operations, turn the pedals to turn the wheel for about 1 minute.

**7** Keep the wheel still without rotating for about 1 minute.

**8** Remove the oil from inside by following the procedures in **Draining out the old oil** above.

**Injecting new oil**

**1** Inject 25ml of new oil into the hub by following steps **Cleaning the inside 1 - 5** above.

**2** Clean off any oil that may have gotten on the hub, etc.





# Dealer's Manual

**SG-S7051-11**

# INSTALLATION

## Installation of sprockets to the hub (SG-S7051-11 / SG-S7051-8 / SM-S705)

Install the following parts to the driver on the right side of the hub body.

- SG-S7051-11 : Right-hand dust cap D
- SG-S7051-8 : Right-hand dust cap B

Next, install the sprocket and secure it in place with the snap ring.

- (x) Outward assembling: MU-UR510 only
- (y) Inward assembling: Compatible with all motor units
- (z) Note the direction

Internal geared hub	Sprocket	Number of teeth on sprocket	
		Outward assembling	Inward assembling
SG-S7051-11	SM-GEAR	16T to 23T	20T to 23T
	CS-S500	18T, 20T	
SG-S7051-8	SM-GEAR	16T to 23T	18T to 23T
	CS-S500	18T, 20T	

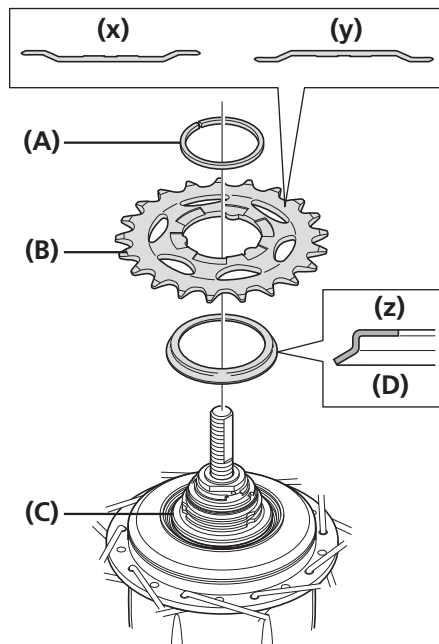

- (A) Snap ring
- (B) Sprocket
- (C) Driver
- (D) Right-hand dust cap B (SG-S7051-8) / Right-hand dust cap D (SG-S7051-11)

### NOTICE

- If using the MU-UR510 motor unit, outward assembling of the sprocket is possible.
- CS-S500 can only be used on models without a chain guide.



Click here for the latest Dealer's Manual

<https://si.shimano.com/DM/S7051>

## Installation of the motor unit to the hub

Unless otherwise noted, MU-UR500 is used as an example for this explanation.

Step 2 describes the procedure for using a shift switch to place the mechanism of the motor unit in the initial position before installation, which is required if the motor unit is not in the factory default setting (during maintenance, etc.).

Refer to "CONNECTION OF THE ELECTRIC WIRES" to place the motor unit in a state where operations can be performed.

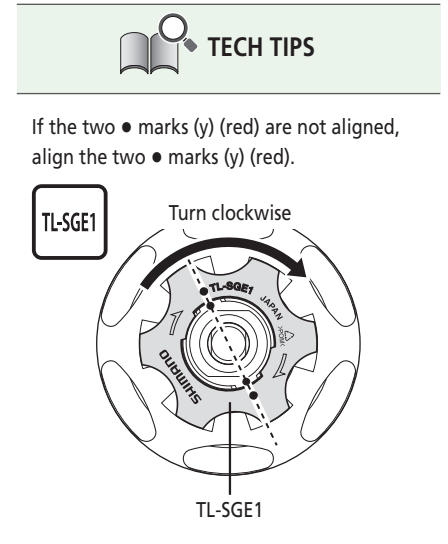
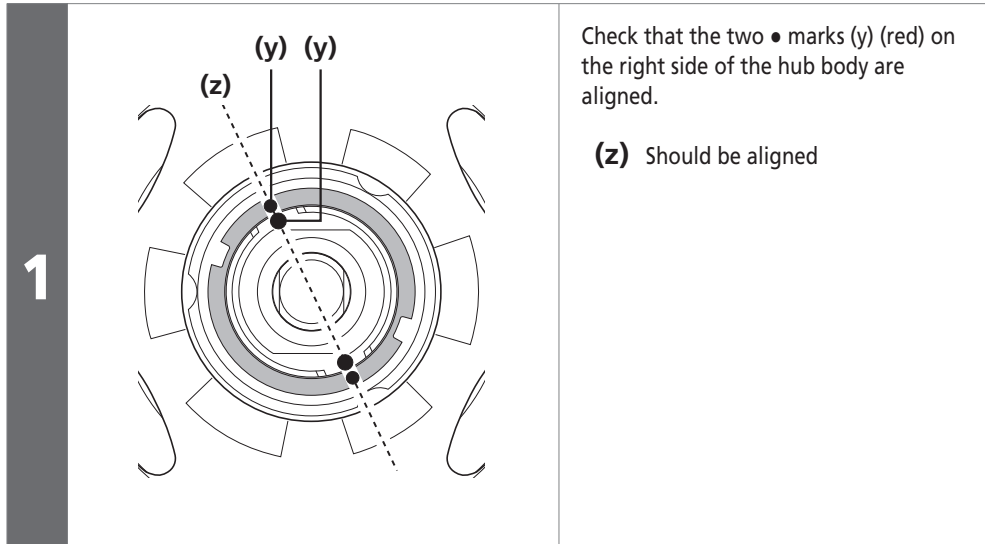

Make sure that the two protrusions on the inside of the motor unit are at the initial positions.

- For MU-UR500 / MU-UR510, confirm that the mark and protrusions are aligned.
- For MU-S705, confirm that the protrusions are positioned as shown in the figure.

MU-UR500

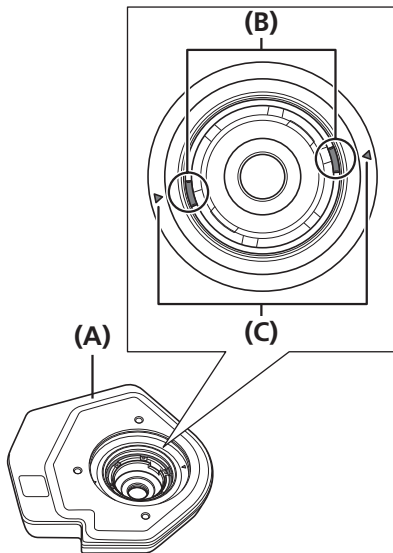

MU-S705

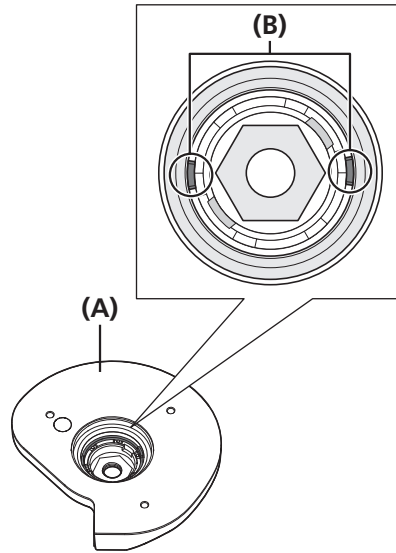

MU-UR510

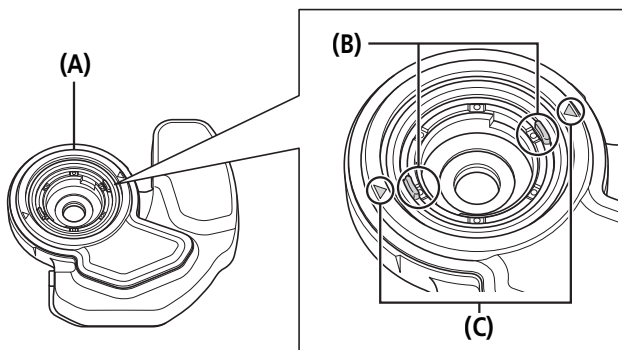

2

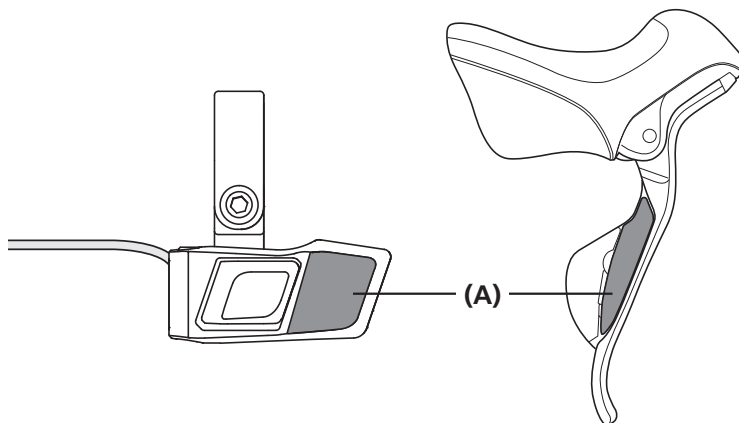

\* If you are using a shifting switch other than the above, press the equivalent switch (on the shift down side) 10 or more times.

- (A) Inside motor unit
- (B) Protrusion
- (C) Mark (MU-UR500 / MU-UR510)

**NOTICE**

Check that the rubber seal is attached. If the rubber seal is not attached, attach as shown in the illustration. There is no compatibility between MU-UR510 / MU-UR500 and MU-S705 rubber seals.

MU-UR500

MU-UR510

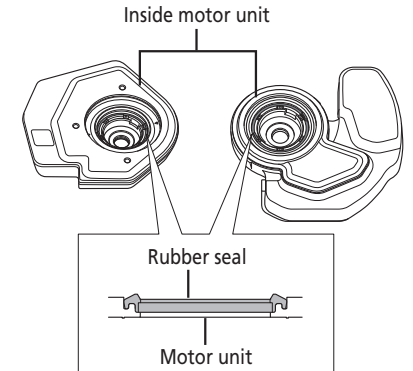

MU-S705

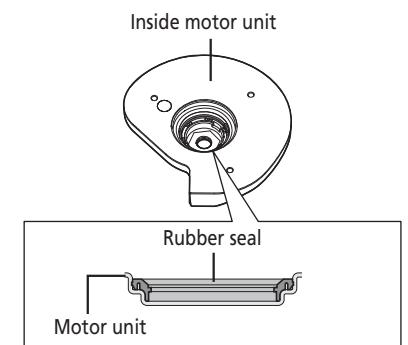

- (A) Shifting switch

**NOTICE**

The motor unit is set at the initial position when it is shipped; therefore, install it without changing the position. If the motor unit may not be at the initial position, push the following shifting switch ten or more times to move the protrusions on the motor unit clockwise (check from the inside of the motor unit). (Check the shifting up and down of the shifting switch in advance as it may have been switched by customization.) If the motor unit is installed off the initial position, some gears may become unavailable and the hub or the motor unit may be damaged.



Click here for the latest Dealer's Manual

<https://si.shimano.com/DM/S7051>

3

Install the motor unit to the hub so that the ● mark (x) on the motor unit is aligned with the ● mark (y) on the hub lock spacer.

After this, gently push the motor unit while turning it slowly to set it correctly until it stops turning on the hub axle.

Next, secure the motor unit by tightening right-hand lock nut B.

- (x) Motor unit ● mark  
MU-UR510 / MU-UR500: Silver  
MU-S705: Yellow
- (y) hub lock spacer ● mark (red)  
This is the mark for which the position was aligned in step 1.
- (z) Outer side

- (A) Right-hand lock nut B
- (B) Right-hand lock nut A
- (C) Motor unit

Tightening torque	
	6 - 10 N·m

NOTICE

Check that the guide of right-hand lock nut A is seated securely in the guide hole on the front of the motor unit.

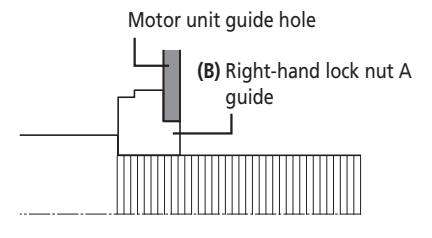

## Installation of the disc brake rotor

Install the disc brake rotor as shown in the illustration.

SG-S7051-8

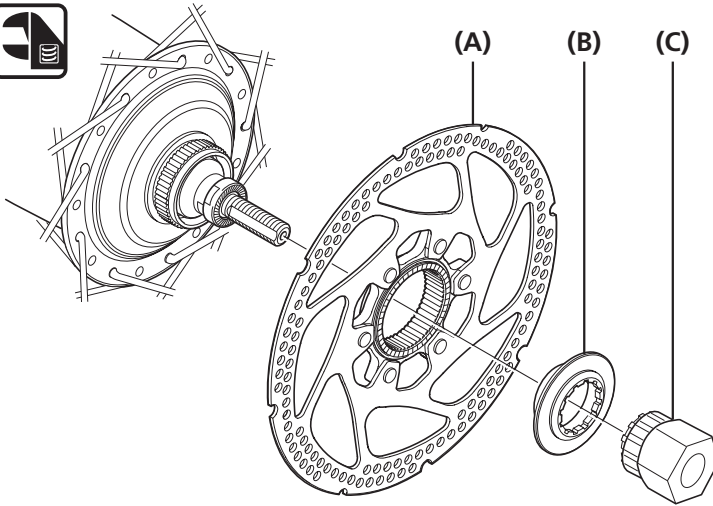

- (A) Disc brake rotor
- (B) Disc brake rotor installation ring
- (C) TL-LR10

### Tightening torque



40 N·m



SG-S7051-11

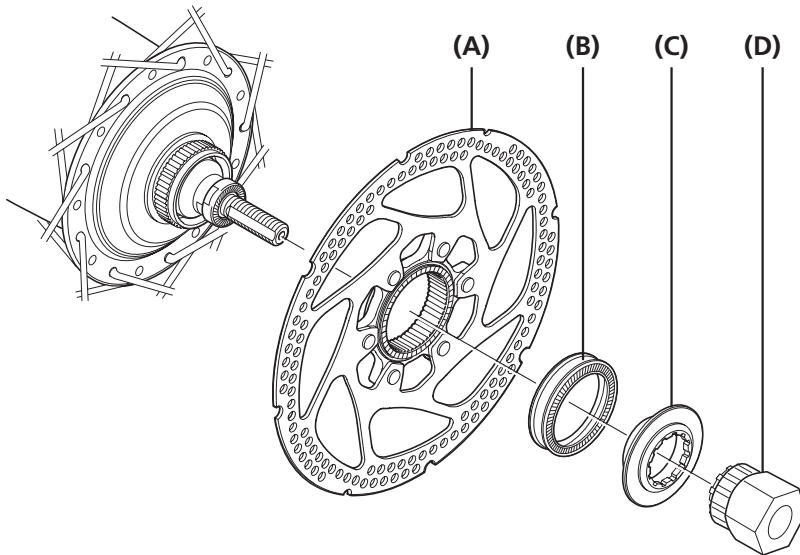

- (A) Disc brake rotor
- (B) Rotor spacer
- (C) Disc brake rotor installation ring
- (D) TL-LR10

### Tightening torque



40 N·m



Click here for the latest Dealer's Manual

<https://si.shimano.com/DM/S7051>

## Installation of the hub to the frame

### Non-turn washer

Use non-turn washers to secure the internal geared hub and motor unit to the frame.

Non-turn washers are classified with a mark and main body color for easy identification. There are left and right types, and the right type is normally used on the chain side.

Refer to the following to select the non-turn washer based on the shape of the motor unit and rear dropout to use.



#### MU-S705

- When the rear dropout is the reversed type

Rear dropout	Installation angle of non-turn washer and motor unit		
	5R (yellow) / 5L (brown)	6R (silver) / 6L (white)	7R (black) / 7L (gray)

- When the rear dropout is the standard type

Rear dropout	Installation angle of non-turn washer and motor unit		
	5R (yellow) / 5L (brown)	6R (silver) / 6L (white)	7R (black) / 7L (gray)



Dealer's Manual (SG-S7051-11)

- When the rear dropout is the straight drop type

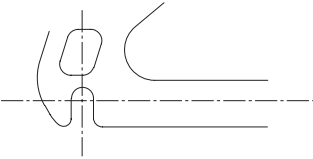
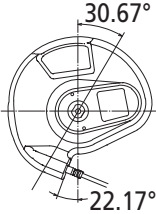
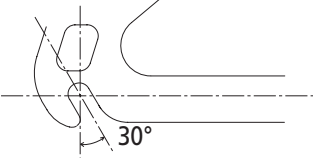
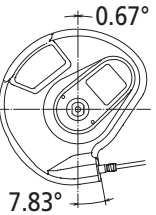
Rear dropout	Installation angle of non-turn washer and motor unit
	8R (blue) / 8L (green)
	
	

MU-UR500

- When the rear dropout is the reversed type

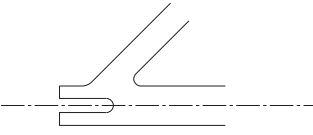
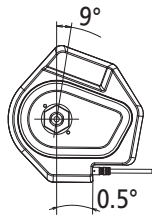
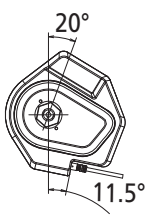
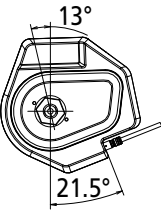
Rear dropout	Installation angle of non-turn washer and motor unit		
	5R (yellow) / 5L (brown)	6R (silver) / 6L (white)	7R (black) / 7L (gray)
			



Click here for the latest Dealer's Manual

<https://si.shimano.com/DM/S7051>

Dealer's Manual (SG-S7051-11)

- When the rear dropout is the standard type

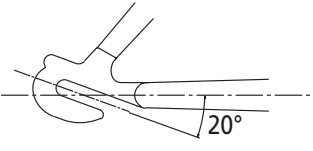
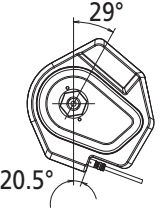
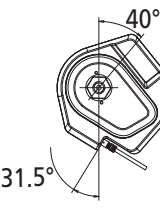
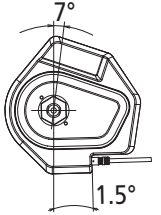
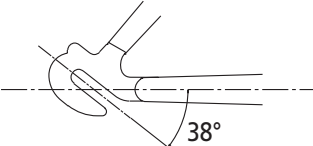
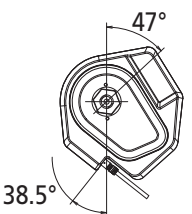
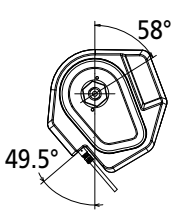
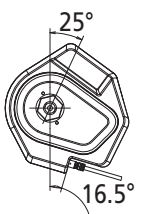
Rear dropout	Installation angle of non-turn washer and motor unit		
	5R (yellow) / 5L (brown)	6R (silver) / 6L (white)	7R (black) / 7L (gray)
			
			

- When the rear dropout is the straight drop type

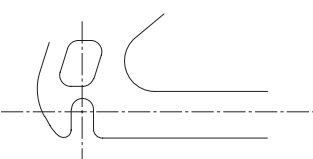
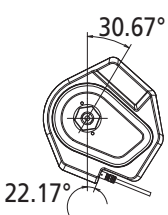
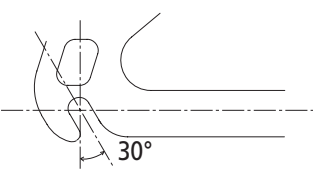
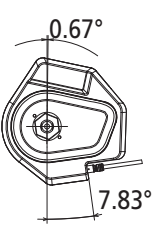
Rear dropout	Installation angle of non-turn washer and motor unit
	8R (blue) / 8L (green)
	
	





Click here for the latest Dealer's Manual

<https://si.shimano.com/DM/S7051>

Dealer's Manual (SG-S7051-11)

MU-UR510

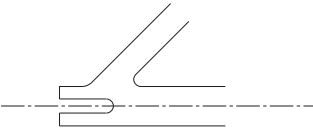

- When the rear dropout is the standard type

Rear dropout	Installation angle of non-turn washer and motor unit
	6R (silver) / 6L (white)
	

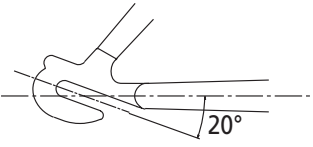
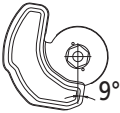
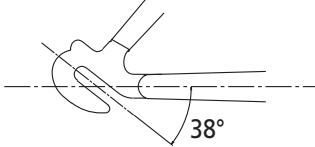
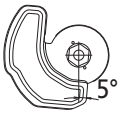
- When the rear dropout is the reversed type

Rear dropout	Installation angle of non-turn washer and motor unit	Rear dropout shape	Installation angle of non-turn washer and motor unit
	5R (yellow) / 5L (brown)		7R (black) / 7L (gray)
			

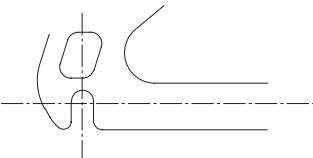
- When the rear dropout is the straight drop type

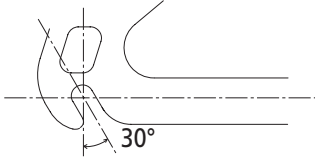
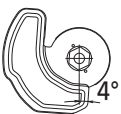
Rear dropout	Installation angle of non-turn washer and motor unit	Rear dropout shape	Installation angle of non-turn washer and motor unit
	8R (blue) / 8L (green)		9R (light green) / 9L (light brown)
			



[Click here for the latest Dealer's Manual](#)

<https://si.shimano.com/DM/S7051>

## Installation methods

The method of installing the hub to the frame is the same when the chain tensioner is being used and when it is not being used.

Mount the chain on the sprocket, then set the hub axle into the rear dropout.

### When not using chain tensioner

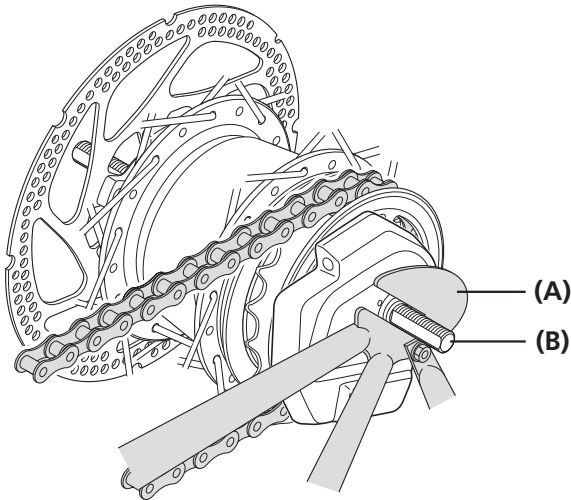

- (A) Rear dropout
- (B) Hub axle

1

### When using chain tensioner

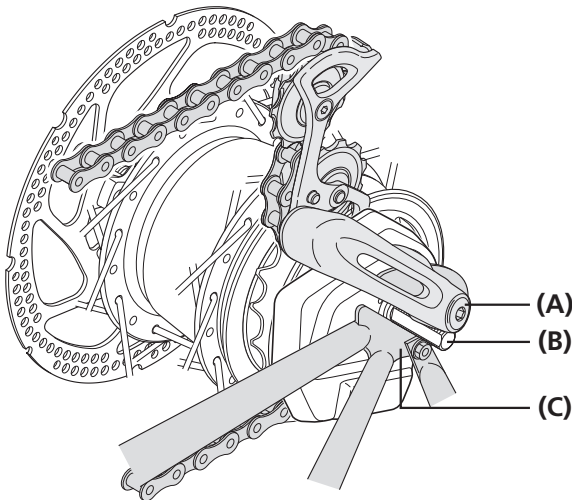

- (A) Chain tensioner
- (B) Hub axle
- (C) Rear dropout

### NOTICE

- A chain tensioner cannot be used with the MU-UR510 motor unit.



### TECH TIPS

When using the chain tensioner, be sure to read the attached owner's manual for the CT-S500 chain tensioner.



Click here for the latest Dealer's Manual

<https://si.shimano.com/DM/S7051>

Place non-turn washers and onto the right and left sides of the hub axle.

At this time, turn the motor unit so that the protrusion of the non-turn washers fit into the grooves of the rear dropout and align the washers to be almost parallel to the chainstay.

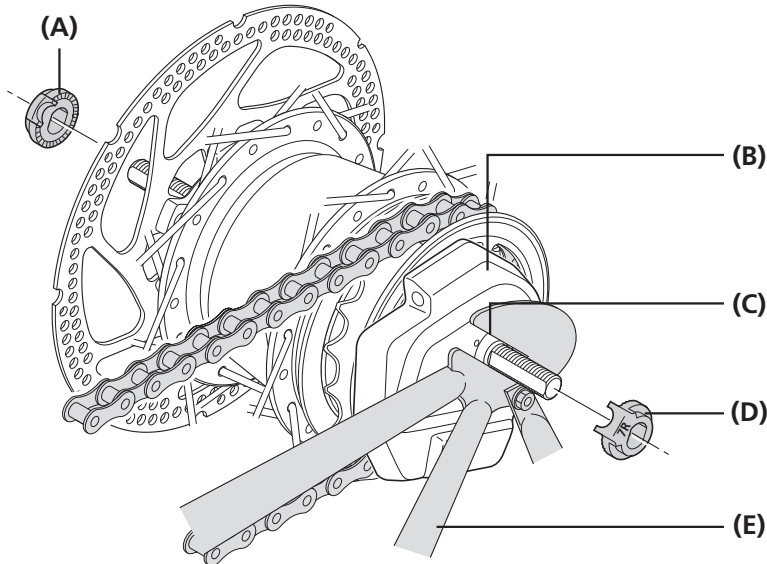

- (A) Non-turn washer (for left-side use)
- (B) Motor unit
- (C) Rear dropout groove
- (D) Non-turn washer (for right-side use)
- (E) Chainstay

 TECH TIPS

- Install the non-turn washer with its protrusion part aligned with the straight part of the rear dropout.

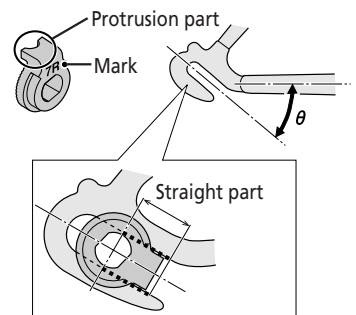

- Install the non-turn washer so that the protrusion fits securely in the rear dropout groove at the front and back sides of the hub axle.

2



Click here for the latest Dealer's Manual

<https://si.shimano.com/DM/S7051>

Take up slack in the chain and secure the wheel to the frame with the hub nut.

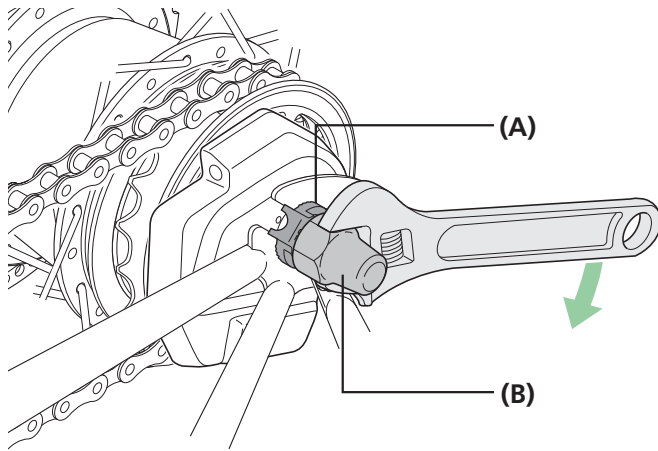

3

- (A) Non-turn washer
- (B) Hub nut

Tightening torque



30 - 45 N·m

NOTICE

- When installing parts such as a mudguard stay to the hub axle, install them in the order shown in the figure.

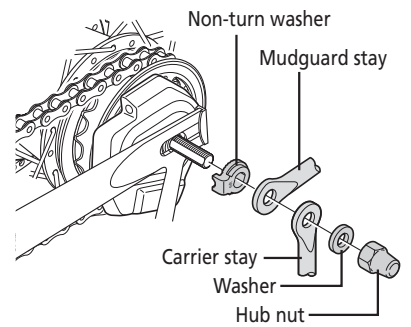

- When installing the hub to the frame, the chain guard may come off, so check that the chain guard is securely installed. If not properly installed, noise may be generated.

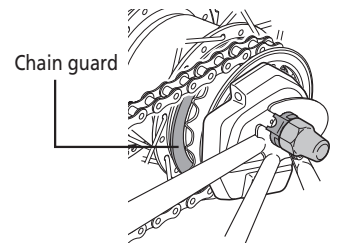

Click here for the latest Dealer's Manual

<https://si.shimano.com/DM/S7051>

■ Connection of junction

External battery mount type (SM-JC40)

**1**

TL-EW02

(A) (B) (z) (C)

Connect the electric wire to the SC-S705 E-TUBE ports and junction [B].

(z) Insert dummy plugs included with the motor unit in unused E-TUBE ports.

- (A) TL-EW02
- (B) Junction [B]
- (C) E-TUBE ports

**NOTICE**

Be sure to push them together until they connect with a click.

**2**

TL-EW02 TL-EW300

(A) (A)

TL-EW02

Connect the electric wires to the motor unit and the battery mount.

- (A) TL-EW02 (MU-UR500 / MU-S705)  
TL-EW300 (MU-UR510)



3

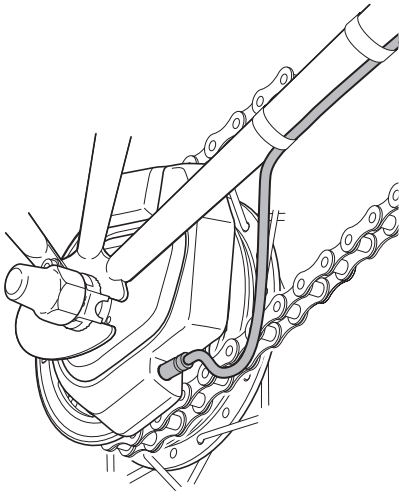

Temporarily secure the electric wire along the frame with tape, and connect it to junction [B].

**NOTICE**

- When routing the electric wire to the motor unit, be sure to install it to the bottom of the chainstay to avoid any interference between the cable and the chain.
- If the motor unit is the MU-UR510, use the EW-AD305 to connect the EW-SD50 and EW-SD300, then connect them to junction [B].

4

Wind any excess length of electric wire inside junction [B] to adjust the length.

Example of adjusting junction [B] length

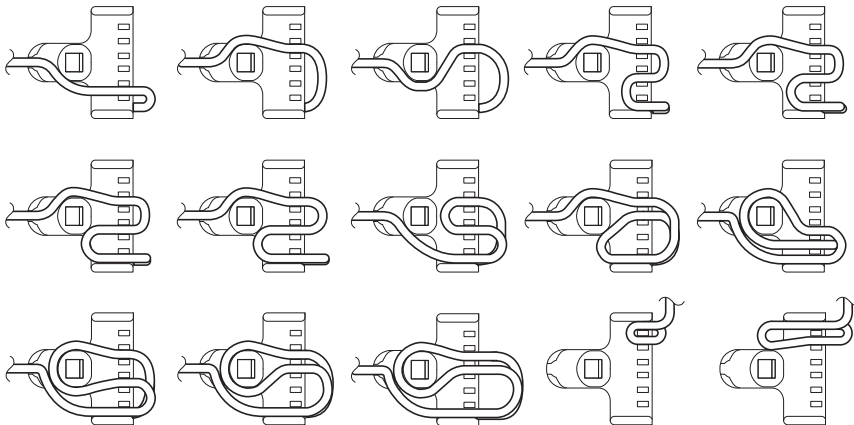

5

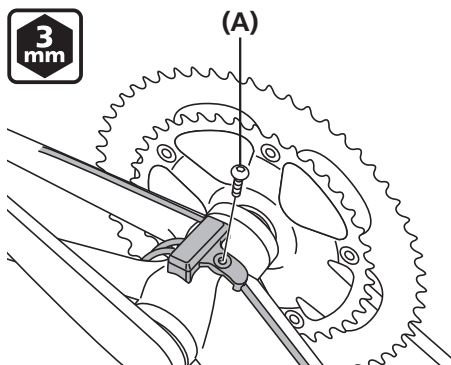

Once the electric wires have been routed, secure junction [B] underneath the bottom bracket shell.

(A) Junction [B] fixing bolt  
(10.5 mm or 15 mm)

Tightening torque



1.5 - 2 N·m



Click here for the latest Dealer's Manual

<https://si.shimano.com/DM/S7051>

6

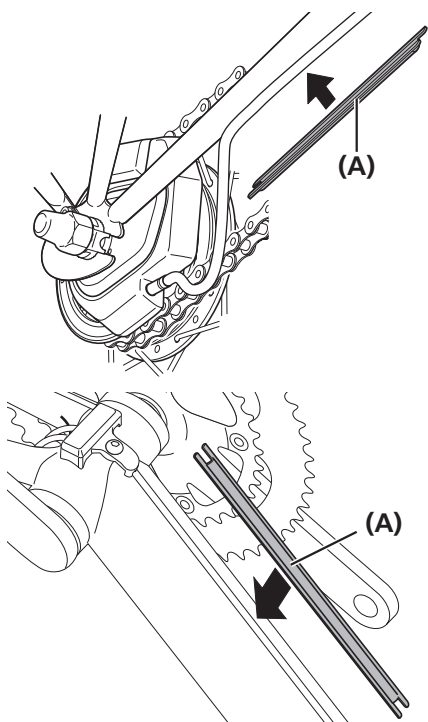

Install the electric wire cover / cord cover onto the frame.

In order to make sure that the electric wire cover / cord cover is securely attached, clean the frame with alcohol or some other cleaning agent to remove any grease or other substances before installing the cover.

Place the electric wire cover / cord cover over the electric wires, then attach it to the frame.

(A) Electric wire cover (EW-SD50 type)  
SM-EWC2  
Cord cover (EW-SD300 type)  
EW-CC300

7

After connecting the electric wires to all of the components, install the battery and check the operation.

Check that gear-shifting of the rear can be performed properly by operating the shifting switch.



## Disconnection of the electric wires

### NOTICE

Do not keep connecting and disconnecting the small waterproof connector. The waterproof section or the connecting section may become worn or deformed, and the function may be affected.

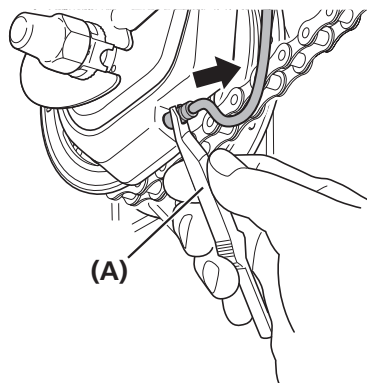
1	<p><b>Motor unit</b></p> <div style="display: flex; align-items: center;"> <div style="border: 1px solid black; padding: 2px; margin-right: 5px;">TL-EW02</div>  </div> <div style="display: flex; align-items: center; margin-top: 5px;"> <div style="border: 1px solid black; padding: 2px; margin-right: 5px;">TL-EW300</div> </div>	<p>Remove the electric wire on the motor unit side.</p>	<p><b>(A)</b> TL-EW02 (MU-UR500 / MU-S705) TL-EW300 (MU-UR510)</p>
---	--	---	--

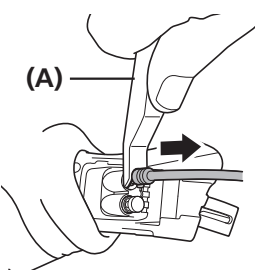
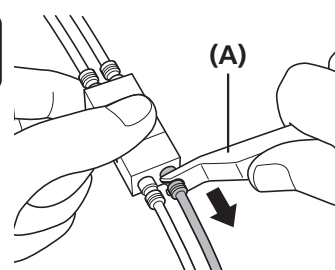
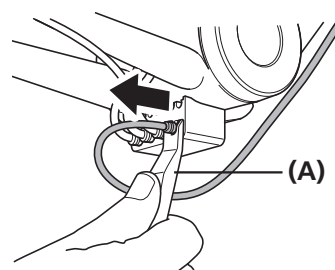
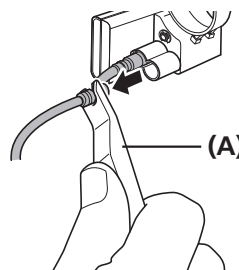
2	<p>When disconnecting the electric wire from a lever, face the flat side toward the lever.</p> <p>When disconnecting the connector of junction, insert the SHIMANO original tool so that the flat side is facing toward junction.</p>		<p><b>(A)</b> TL-EW02</p>
	<p>ST-S705</p> <div style="display: flex; align-items: center;"> <div style="border: 1px solid black; padding: 2px; margin-right: 5px;">TL-EW02</div>  </div>	<p>SM-JC41</p> <div style="display: flex; align-items: center;"> <div style="border: 1px solid black; padding: 2px; margin-right: 5px;">TL-EW02</div>  </div>	
	<p>SM-JC40</p> <div style="display: flex; align-items: center;"> <div style="border: 1px solid black; padding: 2px; margin-right: 5px;">TL-EW02</div>  </div>	<p>SC-S705</p> <div style="display: flex; align-items: center;"> <div style="border: 1px solid black; padding: 2px; margin-right: 5px;">TL-EW02</div>  </div>	

3	<p>Run any excess length of electric wire along the handlebar, and use zip tie or similar to secure the electric wire to the handlebar.</p>
---	---



Click here for the latest Dealer's Manual

<https://si.shimano.com/DM/S7051>

Built-in battery mount type (SM-JC41)

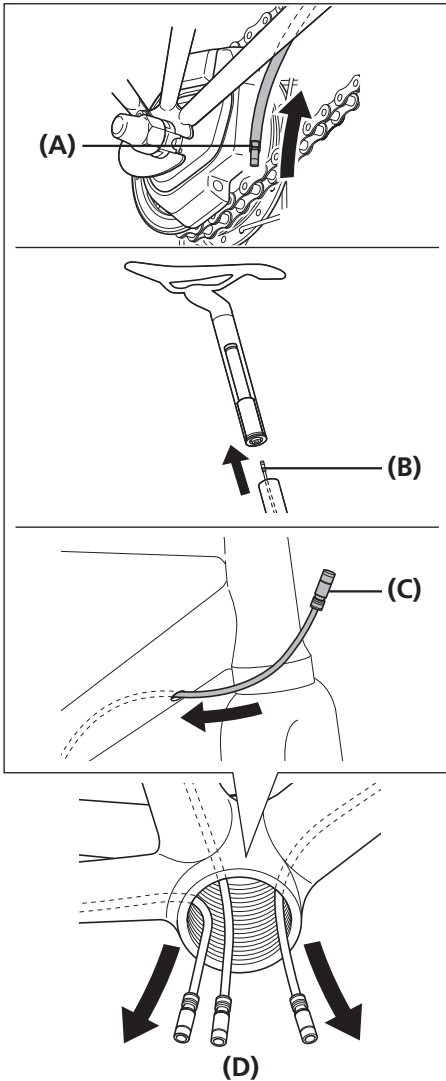

First, insert the electric wire for each of SC-S705, the battery mount, and the motor unit through the hole in the frame to the bottom bracket shell.

- (A) Electric wire for motor unit
- (B) Electric wire for built-in battery
- (C) Electric wire for system information display
- (D) Bottom bracket shell

**NOTICE**

The electric wires have a correct way of being inserted.  
Make sure that you insert them from the direction shown in the illustration.

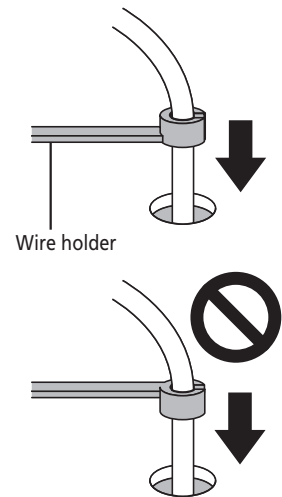

1



**2**

TL-EW02

Connect each electric wire to junction [B].

(z) Insert a dummy plug in the unused E-TUBE ports. (Dummy plugs are included with the motor unit.)

(A)

(A) TL-EW02

**NOTICE**

Be sure to push them together until they connect with a click.

**3**

Connect the electric wires to the system information display, motor unit, and battery mount.

**System information display**

TL-EW02

(A)

**Battery mount**

TL-EW02

(A)

**Motor unit**

TL-EW02

TL-EW300

(A)

(A) TL-EW02  
TL-EW300 (for the MU-UR510)

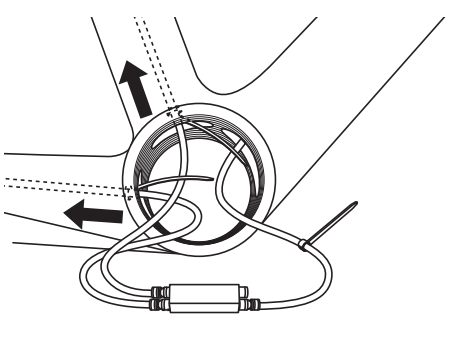
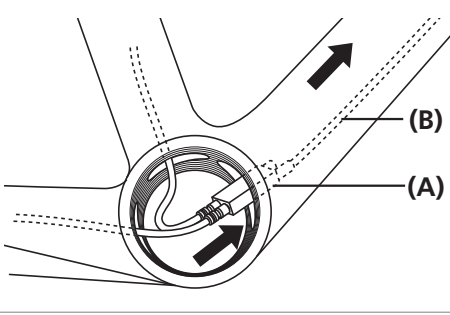
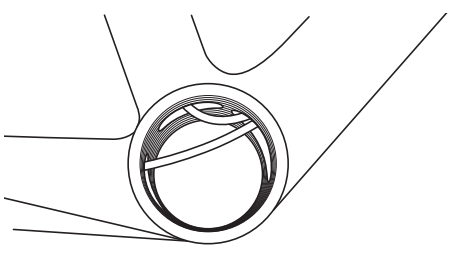

Routing junction [B] and the electric wires inside the frame

<p>1</p>		<p>Pass the electric wires for the motor unit and the built-in battery through the chainstay and the seat tube, respectively.</p>
<p>2</p>		<p>Install the electric wire for the system information display and junction [B] inside the down tube.</p> <p>Check that the screws of the bottom bracket shell do not damage any of the components at this time.</p>
<p>3</p>		<p>Make only the electric wires for the motor unit and the built-in battery visible inside the hanger; push unnecessary protruding components such as the wire holder into the frame.</p>

- (A) Junction [B]
- (B) Electric wire for system information display



## MAINTENANCE

### ■ Adjusting the motor unit

#### Performing adjustment from E-TUBE PROJECT Professional

For the latest information on E-TUBE PROJECT Professional, check <https://bike.shimano.com/e-tube/project.html>.

#### CAUTION

- Improper adjustment may cause gear engagement skipping, resulting in an accidental fall.
- Perform adjustment only when you have an unusual feel during shifting. If there is no problem with shifting, unnecessary adjustment may worsen shifting performance.

**1** Download the latest version of E-TUBE PROJECT Professional from the support website.  
(<https://bike.shimano.com/e-tube/project.html>)

**2** Use the SM-PCE02 to connect the bicycle (system or component) to the PC.

**3** Perform adjustment in E-TUBE PROJECT Professional.  
For the adjustment procedure, refer to the user's manual for E-TUBE PROJECT Professional.  
([https://si.shimano.com/um/7J4WA/gearbox\\_adjustment](https://si.shimano.com/um/7J4WA/gearbox_adjustment))

**4** Finally, ride the bicycle to check whether there is no problem.



## Performing adjustment from E-TUBE PROJECT Cyclist

For the latest information on E-TUBE PROJECT Cyclist, check <https://bike.shimano.com/e-tube/project.html>.

### CAUTION

- Improper adjustment may cause gear engagement skipping, resulting in an accidental fall.
- Perform adjustment only when you have an unusual feel during shifting. If there is no problem with shifting, unnecessary adjustment may worsen shifting performance.

- 1** Download E-TUBE PROJECT Cyclist.
- 2** Refer to "About wireless functions (SC-MT800)" and connect with the smartphone via Bluetooth® LE.
- 3** Perform adjustment in E-TUBE PROJECT Cyclist.  
For the adjustment procedure, refer to the user's manual for E-TUBE PROJECT Cyclist. ([https://si.shimano.com/um/7J4MA/gearbox\\_adjustment](https://si.shimano.com/um/7J4MA/gearbox_adjustment))
- 4** Finally, ride the bicycle to check whether there is no problem.

## For E-BIKE

If a cycle computer is installed to the bicycle with SHIMANO STEPS, adjustment can be performed from the cycle computer. For details, refer to the SHIMANO STEPS Cycle Computer and Switch Unit Parts Dealer's Manual (Gen.2) (<https://si.shimano.com/dm/SCSW002/>).

If a cycle computer is not installed to the bicycle with SHIMANO STEPS or a cycle computer is connected to a drive unit from another manufacturer, refer to "Performing adjustment from E-TUBE PROJECT Professional" or "Performing adjustment from E-TUBE PROJECT Cyclist", depending on the specifications of the component you are using.



## ■ In the case of 11-speed internal geared hub (Oil maintenance kit: Y13098023)

Tools included in the kit: Syringe, Tube, Bleed nipple, O ring, Container

### General Safety Information

#### WARNING

- When replacing the oil, be careful that no oil gets on the disc brake rotor, pads, on the rim when using rim brakes, etc. If oil gets on any of these parts, there is a danger that brake performance may be reduced. Take care of this problem according to the procedures in the brake instruction manual.
- Since there is a risk of explosion or fire, do not smoke, eat, or drink while using this oil. In addition, keep it away from ignition sources such as heat, sparks, open flames, or high temperatures and prevent it from catching fire due to static electricity sparks or other sparks.
- Use only outdoors or in a well-ventilated area. Inhalation of oil mist or vapors may cause nausea. Be careful to provide ventilation and use a respirator type mask. If mist or vapor is inhaled, go immediately to an area with fresh air. Cover up with a blanket. Stay warm and stable and seek professional medical advice.

#### Cautions regarding handling of SG-S700 OIL:

- Use appropriate eye protection when handling, and avoid contact with eyes. In the event of eye contact, flush with fresh water and seek medical assistance immediately. Contact with eyes may result in irritation.
- Use gloves when handling. In the event of skin contact, wash well with soapy water. Contact with skin may cause a rash and discomfort.
- Do not drink. If it is drunk by mistake, do not induce vomiting; make the affected person drink 1 to 2 cups of water and seek medical assistance immediately. If the affected person loses consciousness, do not give the person anything by their mouth. If vomiting occurs naturally, tilt the body to prevent inhalation.
- After use, be sure to wash hands thoroughly.
- Keep the container sealed to prevent foreign objects and moisture from getting inside, and store it in a cool, dark area away from direct sunlight.
- Keep out of reach of children.
- Dispose of used oil, old oil, or oil used for cleaning in accordance with the method stipulated by the law.
- In order to maintain proper performance, it is recommended that you replace the oil once a year from the start of use (or once about every 2,000 km if the bicycle is used very frequently).
- Do not use oil other than SG-S700 OIL. Problems such as an oil leakage and gear shifting malfunction may occur.
- Disposal of used oil: Follow local county and/or state codes for disposal. Use caution when preparing the oil for disposal.
- Read this manual carefully, and keep it in a safe place for later reference.
- For the latest product safety data sheets, check the website <https://si.shimano.com>.

#### TECH TIPS

When using a 1L can of oil, it may become impossible to suck out oil with a syringe when there is only a little oil left. First, transfer all oil to a different container.



▶ Click here for the latest Dealer's Manual

<https://si.shimano.com/DM/S7051>

Internal geared hub: Oil replacement

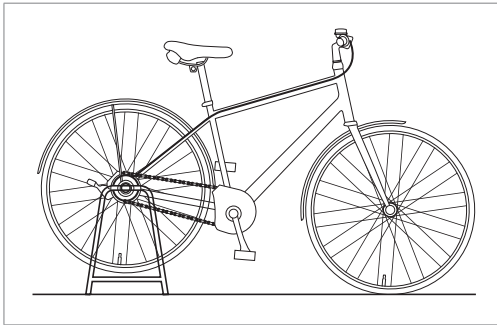

Using a stand, etc., enable the rear wheel to turn while performing work.

Draining out the old oil

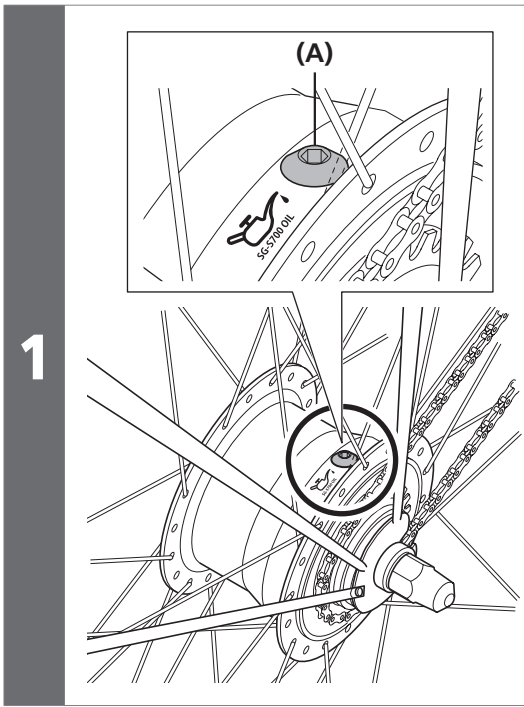

Rotate the wheel slowly until the oil port is facing up.

(A) Oil port

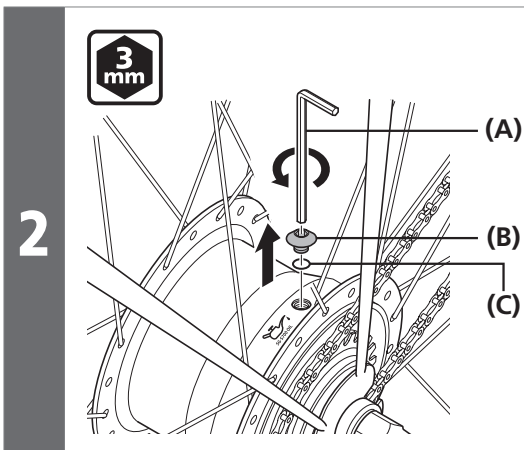

Remove the oil port bolt and O-ring.

- (A) 3 mm hexagon wrench
- (B) Oil port bolt
- (C) O-ring

**NOTICE**

Be careful that the oil port is facing up; if the oil port bolt is loosened when it is not facing up, the oil inside may leak out.



Click here for the latest Dealer's Manual

<https://si.shimano.com/DM/S7051>

Dealer's Manual (SG-S7051-11)

**3**

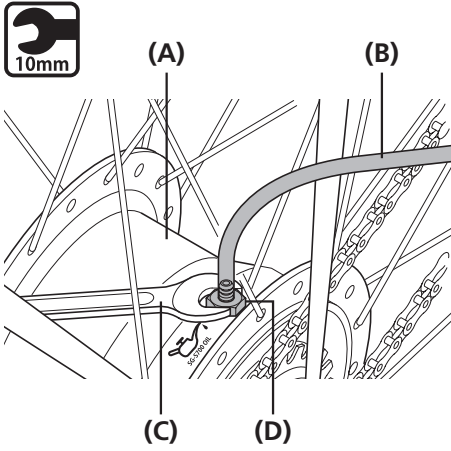

Attach the bleed nipple with tube attached to the hub shell.

- (A) Hub shell
- (B) Tube
- (C) 10 mm spanner
- (D) Bleed nipple

Tightening torque	
	1 - 3 N·m

 **TECH TIPS**

Check that the O-ring is properly installed on the bleed nipple.

**4**

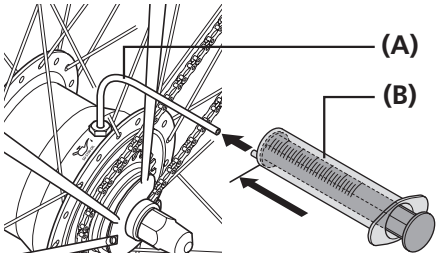

With the piston of the syringe pushed fully in, firmly connect the syringe to the tube.

- (A) Tube
- (B) Syringe

**5**

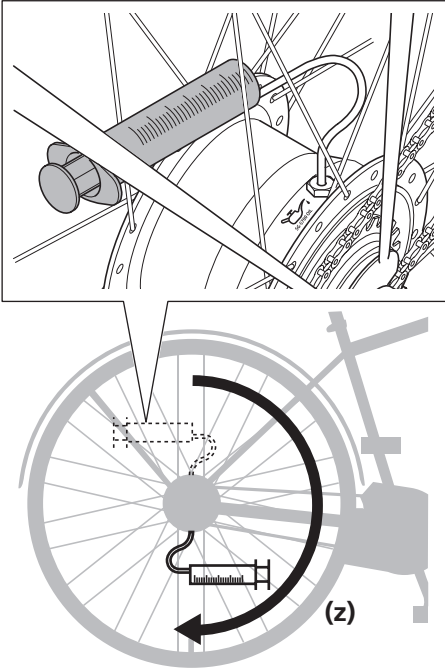

Insert the syringe between the spokes, and slowly turn the wheel forward until the oil port is facing down.

(z) Turn in forward direction

**6** Wait about 5 minutes with the hub kept still and not turning so that the oil settles.



Click here for the latest Dealer's Manual

<https://si.shimano.com/DM/S7051>

Dealer's Manual (SG-S7051-11)

7

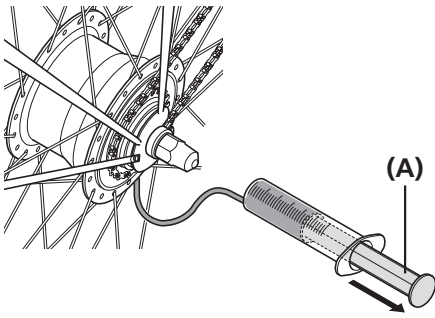

Pull the piston out slowly to draw out the oil inside the hub shell.

(A) Piston

NOTICE

If the piston is pulled out quickly, air is likely to be mixed in.

8

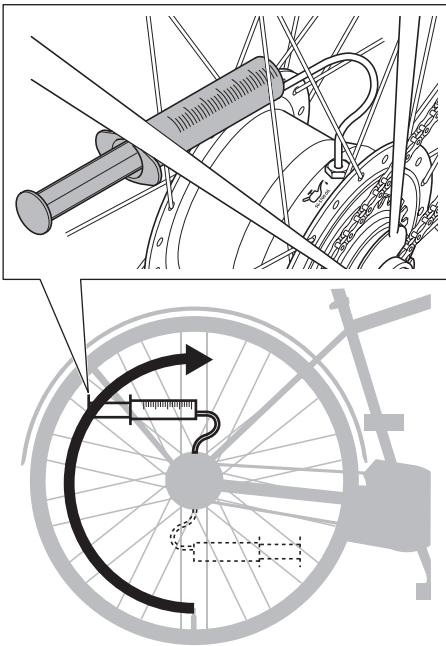

Rotate the wheel slowly until the oil port is facing up.

NOTICE

To make sure that the syringe does not get caught by the chain case, etc., store the syringe between the spokes when turning the wheel.

9

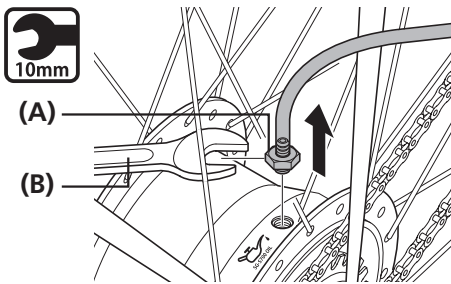

While being careful that the tube does not come off the syringe, remove the bleed nipple.

(A) Bleed nipple  
(B) 10 mm spanner

10

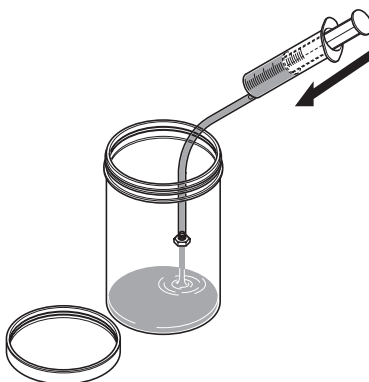

Remove the old oil from the syringe.



Cleaning the inside

1

Attach the bleed nipple to the hub shell.

2

Suck 25 ml of new oil into the syringe and connect it firmly to the tube.

3

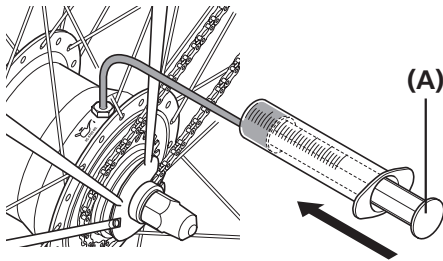

Push the piston to inject the new oil into the inside of the hub.

4

After pulling back the piston to reduce the internal pressure, remove the bleed nipple.

5

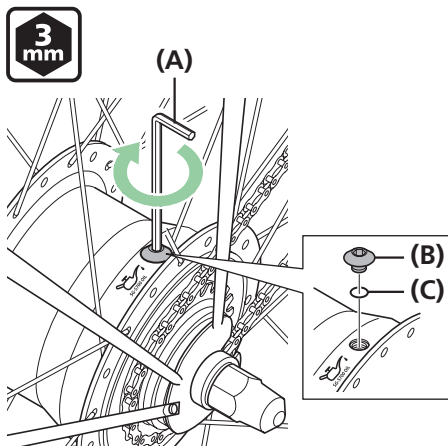

Install the O-ring and the oil port bolt.

Tightening torque



1 - 3 N·m



TECH TIPS

If the syringe or tube becomes dirty when removing old oil or cleaning the inside of the hub, clean the syringe and tube using parts cleaner, etc., if necessary.

(A) Piston



TECH TIPS

When the oil is forced in, the internal pressure will increase and the piston may push back. If the piston is periodically pulled back to reduce the pressure inside the hub, the oil will be easier to inject into the inside of the hub.



TECH TIPS

If the bleed nipple is removed without pulling back the piston, the oil may flow back into the piston together with air from inside the tube and spill out of the piston.

(A) 3 mm hexagon wrench

(B) Oil port bolt

(C) O-ring

Tightening torque



2 - 3 N·m



Click here for the latest Dealer's Manual

<https://si.shimano.com/DM/S7051>

**Dealer's Manual (SG-S7051-11)**

**6** While performing gear-change operations, turn the pedals to turn the wheel for about 1 minute.

**7** Keep the wheel still without rotating for about 1 minute.

**8** Remove the oil from inside by following the procedures in **Draining out the old oil** above.

**Injecting new oil**

**1** Inject 25 ml of new oil into the hub by following steps **Cleaning the inside 1 - 5** above.

**2** Clean off any oil that may have gotten on the hub, etc.



# Troubleshooting

# Troubleshooting

## Check the following prior to performing adjustment or maintenance.

- All of the following occurrences are due to the internal gear-shifting structure and are not the failure of the internal components.

Phenomenon	Type of hub	Gear positions where phenomenon might occur
	For Disk brake/V-brake	
Noise occurs when the pedals rotate.	-	All gear positions except 1st
Noise occurs when the bicycle is pushed backward.	X	All gear positions except 1st
The hub has a built-in mechanism that supports gear shifting* and when the mechanism operates during gear shifting, noise and vibrations occur.	X	All gear positions
Depending on gear position, gear-shifting may feel different.	X	All gear positions
Noise occurs when pedal rotation is stopped during riding.	-	All gear positions

### \*Gear Change Support

SHIMANO gear change support mechanism utilizes some portion of pedaling force at down shifting. The result is a quick and precise downshift with very light feeling on both mechanical and DI2 version of the hub.

#### 40% less shifting force required

Pedaling force is applied against the sleeve to help overcome sleeve return pressure and execute the shift.

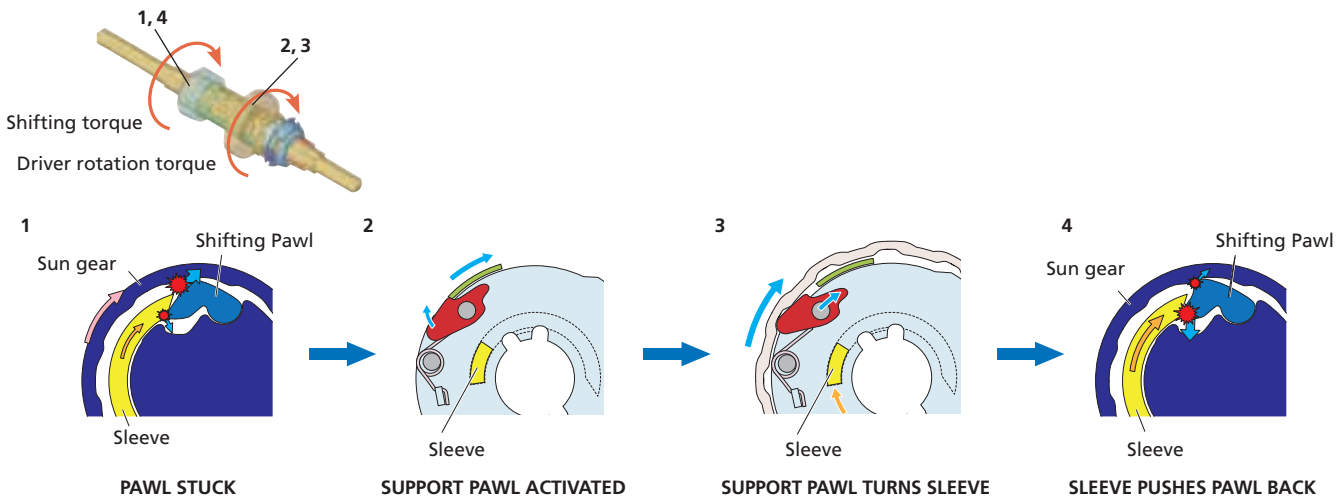

### NOTICE

- If you cannot determine a definite cause for the malfunction, it is recommended to replace the internal assembly. (Refer to p.76)

**Troubleshooting**

		Symptom/cause		Solution	Reference page	
Gear shifting	Gear shifting is poor.	The cable has been routed inappropriately.		Check for any areas where the curvature of the cable is too tight. When using a SHIMANO genuine outer casing, the recommended minimum curvature is R30 mm.	-	
		Cable performance is poor.		Using a SHIMANO genuine cable/outer casing may improve this.	-	
		The cassette joint was adjusted while over-shifted.		Set the gear to 6th from 11th. Adjust the cassette joint again. To avoid over-shifting the shifting lever, change the setting gradually and with minimal force.	P.25	
	Gear shifting is impossible.	The cable was not adjusted properly.		Turn the cable adjustment barrel on the REVOSHIFT lever and align the bracket on the cassette joint with the setting line on the pulley.	P.25	
		Check whether gear shifting is possible with the wheel removed from the frame.	Possible	The wheel was not installed properly to the frame.	Recheck the procedure for installing the hub to the frame.	P.11, P.48
			Not possible	There is a malfunction in the shifting lever.		Replace the lever with a new one.
There is a malfunction in the hub.		If something is broken inside, replace the broken part or unit. If nothing is broken or if you are unsure, replace the internal assembly.		P.76		
Abnormal noise	There is an abnormal noise.	The cable was not adjusted properly.		Set the gear to 6th from 11th. Turn the cable adjustment barrel on the REVOSHIFT lever and align the bracket on the cassette joint with the setting line on the pulley.	P.25	
	The abnormal noise does not stop even after adjusting the cable.	During gear shifting.		Replace the internal assembly.	P.76	
		When pedaling.		If something is broken inside, replace the broken part or unit. If nothing is broken or if you are unsure, replace the internal assembly.	P.76	
When riding	The display on the indicator on the lever differs from the gear position of the hub.	The cable was not adjusted properly.		Set the gear to 6th from 11th. Turn the cable adjustment barrel on the REVOSHIFT lever and align the bracket on the cassette joint with the setting line on the pulley.	P.25	
		Internal unit failure.		If something is broken inside, replace the broken part or unit. If nothing is broken or if you are unsure, replace the entire internal unit.	P.76	
	The hub is difficult to rotate, or does not rotate smoothly.	The cone is too tight.		Adjust the stop nut so that the hub shell can be turned smoothly without any gap. After adjusting, secure the stop nut with the locknut.	P.94	
		Internal unit failure.		If something is broken inside, replace the broken part or unit. If nothing is broken or if you are unsure, replace the entire internal unit.	P.76	
	There is rattling when pedaling.	The area around the cone is damaged.		Replace the right hand cone and driver unit.	P.83	
When not riding	Free rotation is not smooth while not pedaling.		Replace the shell, ball retainer and driver unit.	P.76, P.81, P.83		

**Troubleshooting**

**Oil leak**

	Symptom/cause	Solution	Reference page
Oil leak	Oil leak from Right hand dust cap A	Replace right hand dust cap A	P.76, P.95
	Oil leak from Drive plate seal	Replace Drive plate seal & Lock washer seal	P.82, P.88, P.89
	Oil leak from Seal ring R	Replace Seal ring R	P.85, P.86
	Oil leak from Oil port bolt	Replace Oil port bolt & O-ring	P.96
	Oil leak from Seal ring L	Replace Seal ring L	P.77, P.93

# Disassembly & Assembly

## Required Tools & Parts

**A: Hammer**

**B: TL-S701**

**C: TL-S702**

**D: TL-S704**

**E: 3mm hexagon wrench**

**F: TL-HS37 Hub spanner 17 mm**

**G: TL-HS35 Hub spanner 15 mm**

**H: 10mm spanner**

**I: Slotted Screwdriver**

**J: TL-AF10**

**K: Cassette joint**

**L: TL-S703 Oil Kit**



# Replacing the Internal Assembly

Refer to the part breakdown (p.108~109) for the names of parts.

1. Hold the two beveled surfaces of the hub axle on the brake arm side in a vise and remove the dust cap A using TL-AF10. When removing the dust cap A, engage the four tabs on TL-AF10 in the indentations on the dust cap A.



## NOTICE

- Forcibly pulling it may cause damage to the bracket cover because of its material properties.
- Do not damage the threads of the hub axle.

2. Turn the hub upside down and hold the two beveled surfaces of the hub axle on the sprocket side in a vise.

- (1) Secure the hub back into place with the drive side downward.
- (2) Use TL-HS35 and TL-HS37 to remove the lock nut and left hand cone.



## NOTICE

- Do not damage the threads of the hub axle.

3. Remove the hub shell.



Replacing the Internal Assembly

4. Remove the seal ring L and ball retainer from the hub shell.



**NOTICE**

- Do not damage the threads of the hub axle.

5. The internal assembly can be replaced.



# Disassembling the Internal Assembly

## Installing the cassette joint

With the brake arm facing downward, pinch the flat portion of the axle with a vise, and secure the internal assembly in place.

### 1. Set the cassette joint.

- (1) Turn the cassette joint pulley in the direction of the arrow to align the red ● marks on the pulley and the bracket.
- (2) Install it with the red ● marks on the cassette joint aligned with the red ● marks on the right side of the hub body.

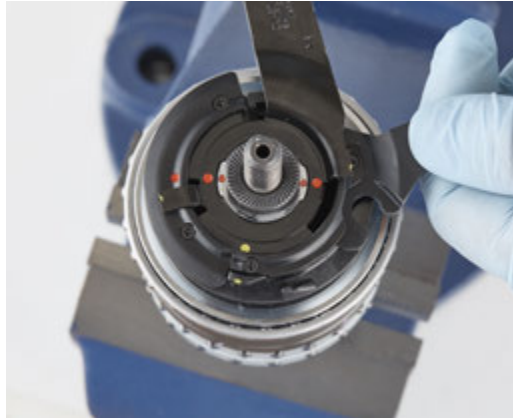

### 2. When installing the cassette joint mounting ring, align the yellow ● mark with the yellow ● mark on the pulley of the cassette joint.



### 3. Turn the cassette joint mounting ring 45° clockwise.

Hold down the bracket securely when performing work.



**Disassembling the Internal Assembly**

When disassembling or assembling the internal assembly, turn the cassette joint until it makes contact and ensure that the unit is in 1st gear (the tabs on the hub axle are folded down) before working. It will be easier to keep the unit in 1s gear if you connect a compatible shifting lever.



**1. Remove the O-ring.**



**2. Carefully remove the stop ring with a slotted screwdriver.**



**NOTICE**

- The Stop ring detaches with some force, so be careful not to lose it.
- Do not reuse a Stop ring that has been removed.

Disassembling the Internal Assembly

**3. Remove the entire assembly including the carrier 1 unit.**



**4. Disassemble the removed assembly to individual parts.**

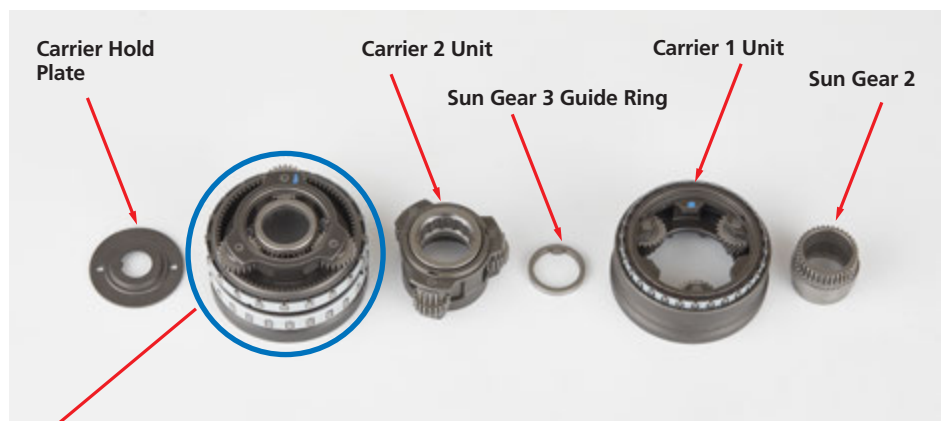

Disassembling the Internal Assembly

**5. Remove the ball retainer S.**



**6. Reverse axle unit in vice to access the drive side cone assembly.**



**7. Remove the cassette joint.**

Follow the reverse procedure from "Installing the cassette joint."



Disassembling the Internal Assembly

8. Remove the right-hand lock nut.



9. Remove the joint nut stop washer.



10. Remove the lock washer and lock washer seal.



Disassembling the Internal Assembly

11. Remove the drive plate seal.

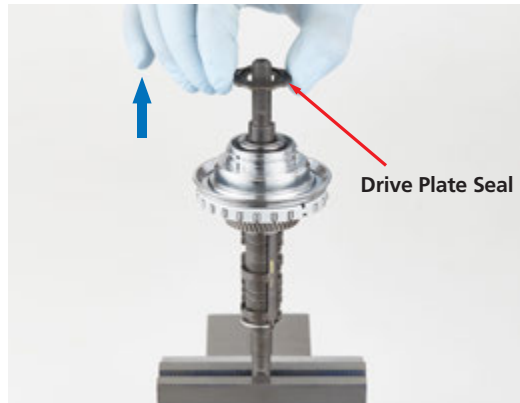

12. Remove the hub axle.

(1) Place the driver assembly on the vise.

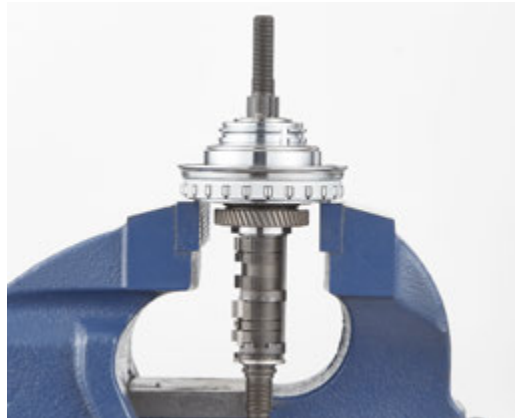

NOTICE

- Place the driver assembly and vise so that they are in the correct position. Otherwise, the part may detach or be damaged, making it impossible to reinstall it.

(2) Set TL-S701 as shown in the figure.

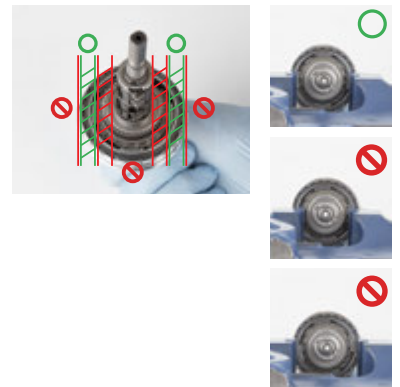

Disassembling the Internal Assembly

- (3) Use a hammer to strike TL-S701.
- Use your hand to support the hub axle while you strike it.

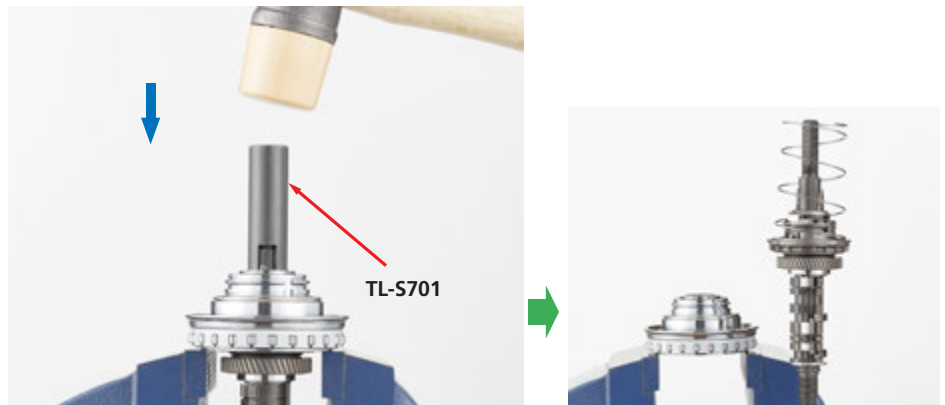

**13. Remove the return spring A.**



**14. Remove the clutch unit by turning it counterclockwise and aligning the two teeth to the two grooves, as shown.**



Disassembling the Internal Assembly

**15. Remove the right-hand cone from the driver unit.**



**16. Remove the seal ring R and ball retainer P from the driver unit.**



**NOTICE**

- Do not reuse a seal ring R that has been removed.

**This completes the disassembly of the INTER-11 coaster hub.**



# Assembling the Internal Assembly

1. Install the ball retainer P and new seal ring R on the driver unit. Push in the seal ring R using TL-S704.



2. With the hub axle unit mounted in a vice, align the two teeth on the clutch unit with the two notches in the hub axle unit. Turn the clutch unit clockwise until it is in its final position as shown.

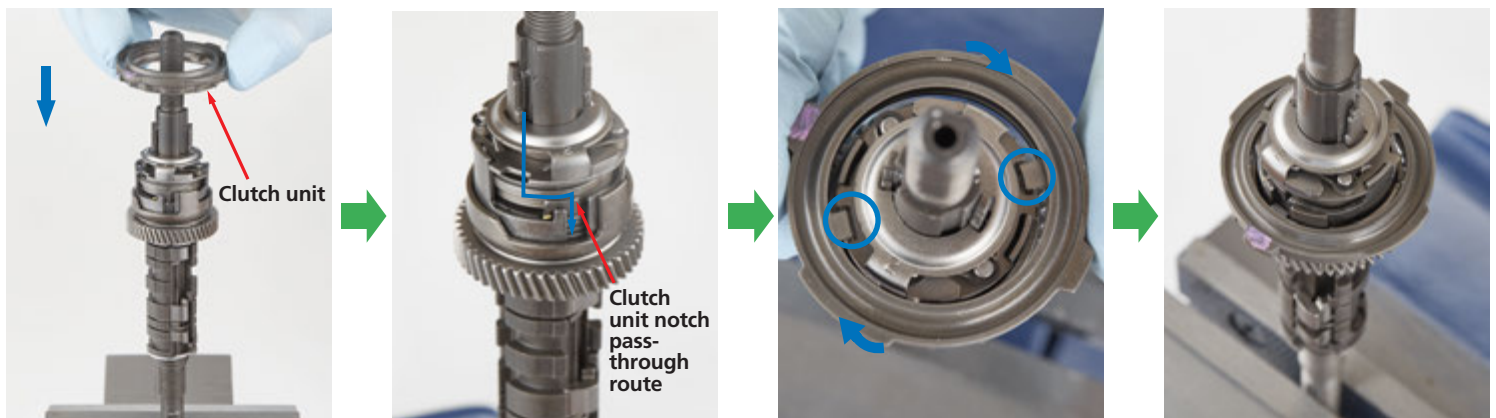

Assembling the Internal Assembly

- 3.** Install the return spring A with the largest coil downward. The spring should sit in the groove on the clutch unit. Be careful not to install the return spring A upside down.

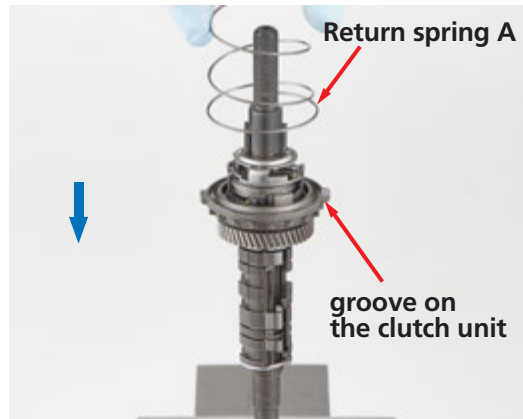

- 4.** Assemble the driver unit by aligning the more shallow notch on the driver unit with the wider tooth on the clutch unit. Rotate the driver counterclockwise to hold the compressed spring in position.

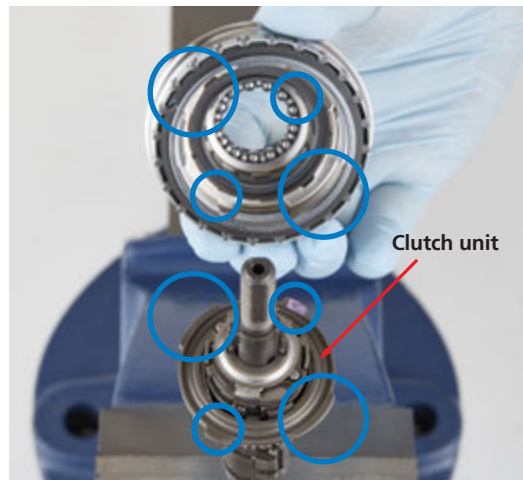

Assembling the Internal Assembly

5. When installing the right hand cone, align the two serrations with the grooves in the axle.



6. Set the cone installation tool (TL-S702) and strike it until it comes to a stop.



NOTICE

- Make sure the right hand cone is completely seated, as shown and the seal is installed equally.

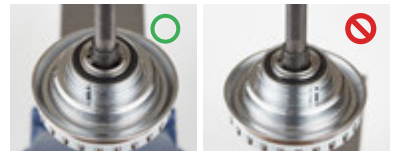

7. Install the driver plate seal. Be careful of the setting direction as shown in the picture.

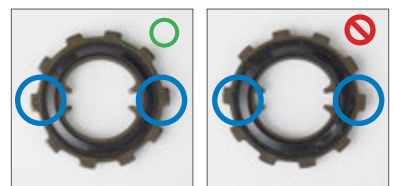
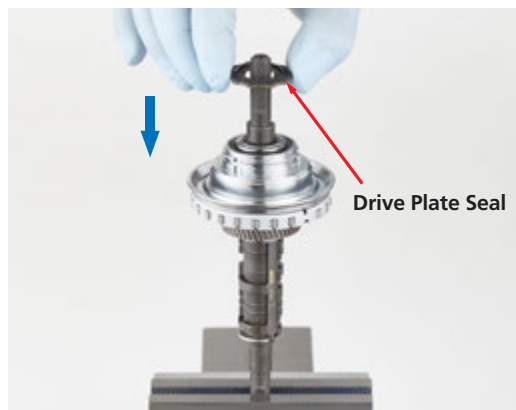

Assembling the Internal Assembly

8. Assemble the lock washer, lock washer seal, and joint nut stop washer and install on the hub axle.

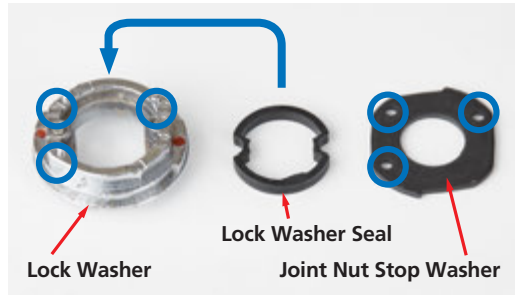

**NOTICE**

- Make sure the lock washer seal is completely seated, as shown and the seal is installed equally.

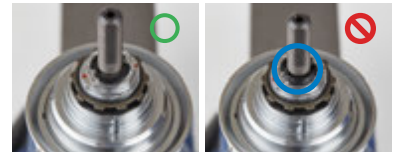

9. Tighten the right-hand lock nut.



**NOTICE**

- If either the lock washer or driver plate rotates during this step, return to assembly step 5 and make sure that the cone is correctly seated.

Assembling the Internal Assembly

**10. Install the cassette joint.**  
Refer to "Installing the cassette joint."



**11. Reverse the axle unit in the vice to complete assembly.**



**12. Install the ball retainer S.**



**NOTICE**

- Be careful, as the balls can easily fall from the retainer.
- Keep the vertical direction of the ball retainer in mind as you set it.

Assembling the Internal Assembly

**13.** Install the carrier 1 unit.



**14.** Install the sun gear 2.



**15.** Install the carrier 2 unit.



Assembling the Internal Assembly

- 16.** Install the sun gear 3 guide ring. When installing, align the serration on the sun gear 3 guide ring with the groove on the hub axle.



- 17.** Assemble the carrier 3 unit, carrier 3 slide spring, sun gear 4, and sun gear 4 slide spring and install on the hub axle.

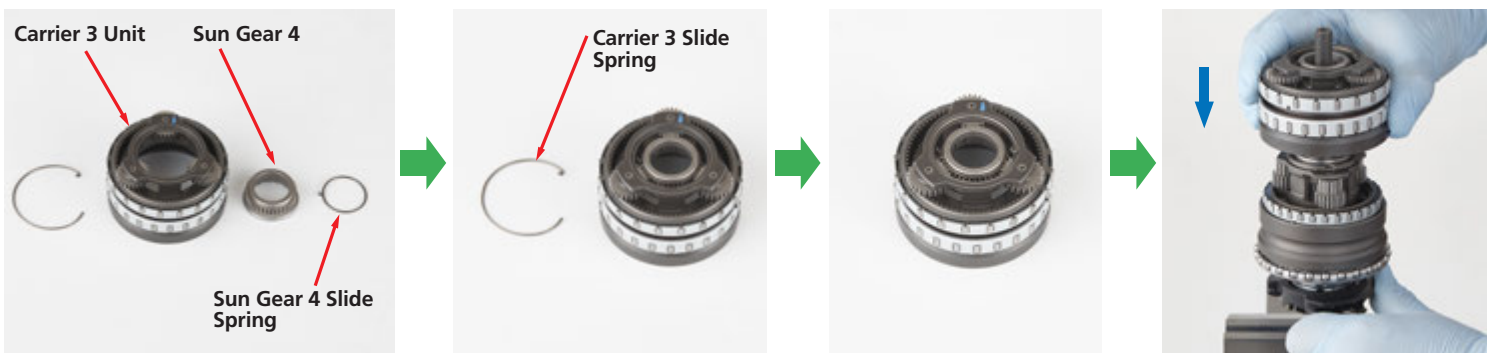

- 18.** Install the carrier hold plate. When installing, ensure that the protrusions on the sun gear 4 slide spring and carrier 3 slide spring edges are engaged in the two holes in the carrier hold plate.

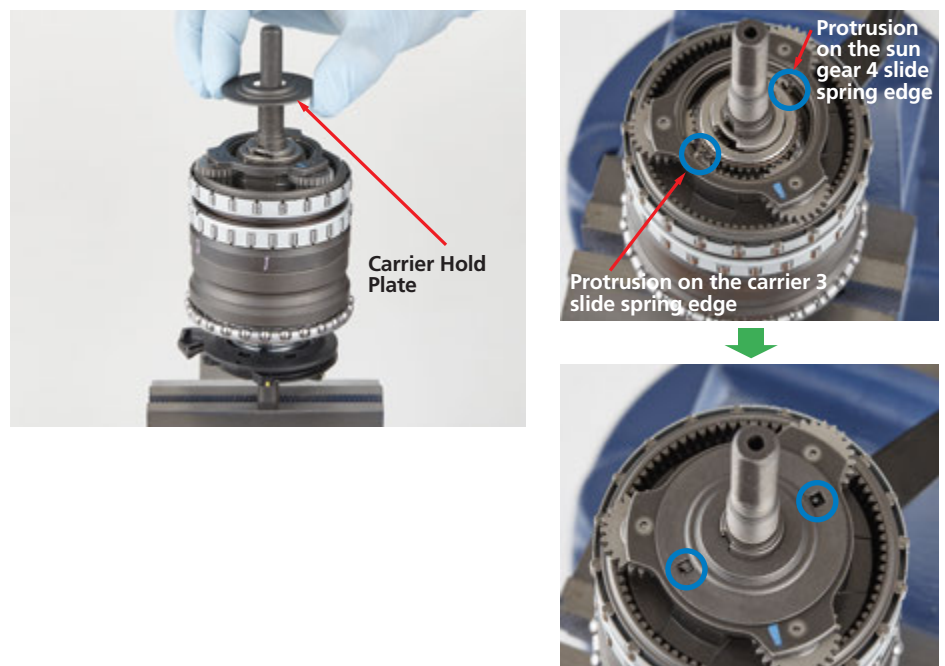

Assembling the Internal Assembly

19. Insert the stop ring.



NOTICE

- If there is no visible groove to receive the stop ring, it is likely that the ring gear and carrier unit are not properly assembled, return to assembly step 14.

20. Install the O-ring.



21. Install the ball retainer and new seal ring L on the hub shell.  
Push in the seal ring R using TL-S704.



Assembling the Internal Assembly

**22. Install the hub shell.**



**23. Screw the left hand cone to adjust so that the hub shell can be turned smoothly without any play. After adjusting, secure the stop nut with the locknut.**



**24. Turn the unit over, secure it back in the vise, and then remove the cassette joint. Follow the reverse procedure from "Installing the cassette joint."**



Assembling the Internal Assembly

- 25.** Install the dust cap A using TL-AF10.  
When installing the dust cap A, engage the four tabs on TL-AF10 in the indentations on the dust cap A.



- 26.** Assembly is now complete.



# Changing Oil

For details, see "Oil maintenance of the internal assembly" in the Dealer's Manual.

## Draining/Injecting Oil

**1. Remove the oil port bolt and O-ring.**



**2. Attach the syringe (TL-S703) tube bleed nipple into the hub shell.**



**3. Slowly move the syringe (TL-S703) piston to drain the oil inside or inject oil.**



# Service Parts & Tools

# Service Parts and Tools

## Cassette Joint



**CJ-C7000**



**CJ-C7000BD**

The Belt Drive specifications is designed to not interfere with the belt drive.

**CJ-C7000**

**CJ-C7000BD**













## Measurement Tool

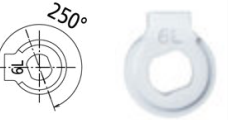

**TL-S700-B**

## NEXUS non-turn washers

The shape of the dropout determines which NTW to choose. In the illustration below, you can see the result for various frame dropouts in combination with the chosen NTW.

	5R/L	6R/L	7R/L	8R/L	9R/L
For right hand side	 <p>5R: Yellow</p>	 <p>6R: Silver</p>	 <p>7R: Black</p>	 <p>8R: Dark blue</p>	 <p>9R: Light green</p>
For left hand side	 <p>5L: Brown</p>	 <p>6L: White</p>	 <p>7L: Gray</p>	 <p>8L: Dark green</p>	 <p>9L: Light brown</p>

\*See Technical Information for the latest information

	5R/L	6R/L	7R/L	8R	8L	9R/L	
Reversed type rear dropout					-	-	
Standard type rear dropout					-	-	
					-	-	
Vertical type rear dropout		-	-	-			-
		-	-	-			-

# Interchangeability

## Interchangeability

		Compatible Products
Internal Unit	SG-S7051-11	SG-S7051-11 SG-S705
	SG-S7001-11	SG-S7001-11 SG-S700

(NOTE) \*The specifications differ depending on the length of the axle etc. Therefore, follow the compatibility of the axle length and such.

# Hub dimensions

## (Over Locknut Dimensions and Axle)

# Hub dimensions (Over Locknut Dimensions and Axle)

## SG-S7001-11

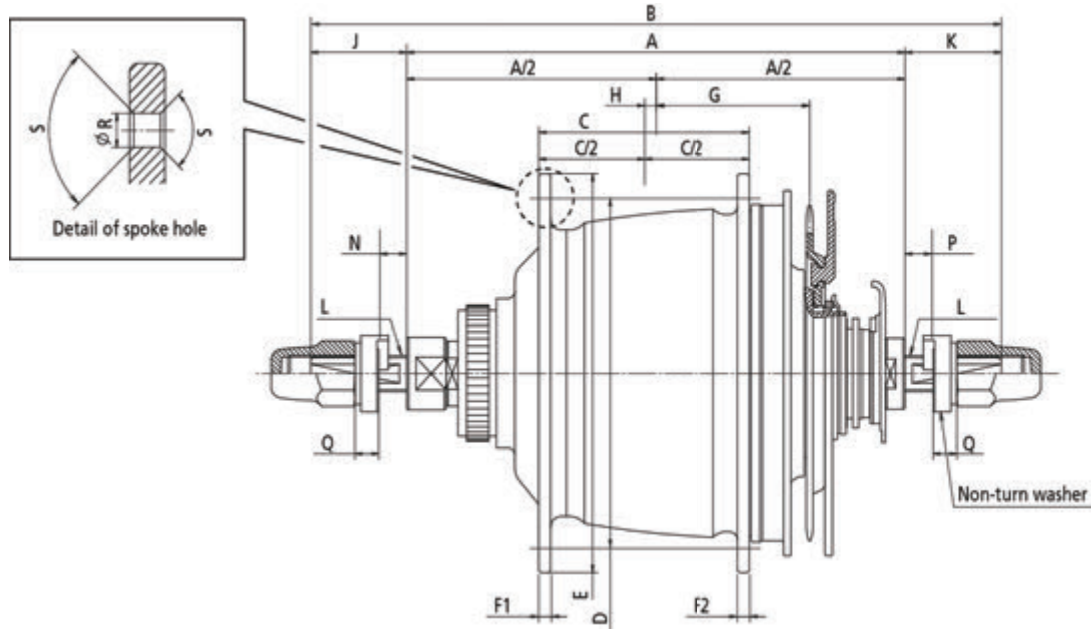

Series	ALFINE			NEXUS		
	INTER-11	INTER-8	INTER-8	INTER-8	INTER-8	INTER-8
Function name	INTER-11	INTER-8	INTER-8	INTER-8	INTER-8	INTER-8
Model No.	SG-S7001-11	SG-S7001-8	SG-C6011-8R SG-C6001-8R SG-C6011-8V SG-C6001-8V	SG-C6001-8C	SG-C6001-8D	SG-C6001-8CD
Speed	11	8				
Gear ratio: Total	409%	307%				
Spoke size	#13 / #14					
A Over locknut dim. / O.L.D. (mm)	135	132	132	135		
B Axle length (mm)	187	184			187	
C Flange distance (mm)	57.3	58.3			57.3	58.3
D Spoke hole P.C.D. (mm)	92.6					
E Flange diameter (mm)	104.3	105.2				
F	Flange width (mm): F1 (left)		3.2			
	Flange width (mm): F2 (right)		3.2			
G	Chain line (mm): G1 (outward assembly)		46.8	47.7	47.9	46.8
	Chain line (mm): G2 (inward assembly)		41.8	42.7	42.9	41.8
H	Offset (mm)		3.1	2.7	2.6	3.1 4
J	Axle length from hub (left)		26		25.7	26 26.6
K	Axle length from hub (right)		26			25.4
L	Axle size BC3 / 8 TPI 26					
N	Rear dropout mounting width (left, includes stay etc.)		5-9	4-9		5-9 4-9
P	Rear dropout mounting width (right, includes stay etc.)		5-9	4-9		5-9 4-9
Q	Non-turn washer width 6.4					
R	Spoke hole diameter (mm)		2.9	2.9	2.9	2.9 2.9 2.9
S	Spoke hole chamfer 90°					

Hub dimensions

SG-S7001-11

Series		NEXUS				
Function name		INTER-7		INTER-7	INTER-5E	INTER-5E
Model No.		SG-C3001-7R	SG-C3001-7C	SG-C3001-7D	SG-C7000-5D	SG-C7000-5R SG-C7000-5V SG-C7000-5C
Speed		7			5	
Gear ratio: Total		244%			263%	
Spoke size		#13 / #14				
A	Over locknut dim. / O.L.D. (mm)	130		127	135	
B	Axle length (mm)	182	201	176	187	
C	Flange distance (mm)	54.6	56.2	54.6	57.3	58.3
D	Spoke hole P.C.D. (mm)	87	83.5	87	92.6	
E	Flange diameter (mm)	99.6	92.5	99.6	105.2	
F	Flange width (mm): F1 (left)	3.2	2.7	3.2		
	Flange width (mm): F2 (right)	3.2	2.3	3.2		
G	Chain line (mm): G1 (outward assembly)	45.3	46.5	46.8	47.2	
	Chain line (mm): G2 (inward assembly)	40.3	41.5	41.8	42.2	
H	Offset (mm)	3.85	4.6	2.5	3.2	3.2 3.7(-5C spec.)
J	Axle length from hub (left)	26	37	24.5	26	
K	Axle length from hub (right)	26	34	24	26	
L	Axle size	BC3 / 8 TPI 26				
N	Rear dropout mounting width (left, includes stay etc.)	4-9	15-20	4-9	5-9	
P	Rear dropout mounting width (right, includes stay etc.)	4-9	12-17	4-9	5-9	
Q	Non-turn washer width	6.4				
R	Spoke hole diameter (mm)	2.9	2.7	2.9		
S	Spoke hole chamfer	90°	105°	90°		

Hub dimensions

SG-S7051-11

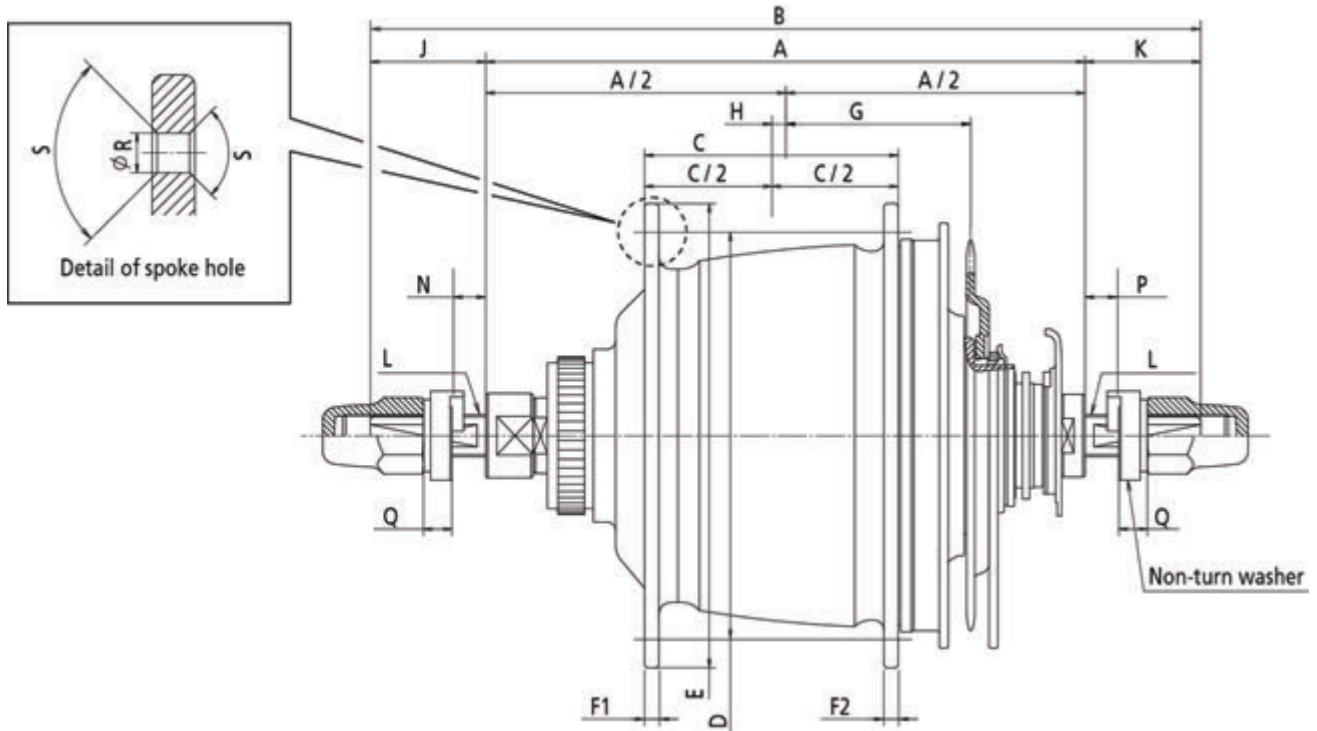

Series	ALFINE		NEXUS			
Function name	INTER-11	INTER-8	INTER-8			
Model No.	SG-S7051-11	SG-S7051-8	SG-C6061-8R	SG-C6061-8C	SG-C6061-8D	SG-C6061-8CD
Speed	11		8			
Gear ratio	409%		307%			
A	Over locknut dim. / O.L.D. (mm)		135			
B	Axle length (mm)		187			
C	Flange distance (mm)		57.3	58.3	57.3	58.3
D	Spoke hole P.C.D. (mm)		92.6			
E	Flange diameter (mm)		104.3	105.2		
F	Flange width (mm): F1 (left)		3.2			
	Flange width (mm): F2 (right)		3.2			
G	Chain line (mm): (inward assembly)		41.8			
H	Offset (mm)		3.15	3.1	3.7	3.3
J	Axle length from hub (left)		26			
K	Axle length from hub (right)		26			
L	Axle size		BC3 / 8 TPI 26			
N	Rear dropout mounting width (left, includes stay etc.)		5-9			
P	Rear dropout mounting width (right, includes stay etc.)		5-9			
Q	Non turn washer width		6.4			
R	Spoke hole diameter (mm)		2.9			
S	Spoke hole chamfer		90°			

Hub dimensions

SG-S7051-11

Series		NEXUS			
Function name		INTER-5E			
Model No.		SG-C7050-5D	SG-C7050-5R	SG-C7050-5C	SG-C7050-5V
Speed		5			
Gear ratio		263%			
Total					
A	Over locknut dim. / O.L.D. (mm)	135			
B	Axle length (mm)	187			
C	Flange distance (mm)	57.3		58.3	
D	Spoke hole P.C.D. (mm)	92.6			
E	Flange diameter (mm)	105.2			
F	Flange width (mm): F1 (left)	3.2			
	Flange width (mm): F2 (right)				
G	Chain line (mm): (inward assembly)	42.2			
H	Offset (mm)	3.2		3.7	
J	Axle length from hub (left)	26			
K	Axle length from hub (right)				
L	Axle size	BC3 / 8 TPI 26			
N	Rear dropout mounting width (left, includes stay etc.)	5-9			
P	Rear dropout mounting width (right, includes stay etc.)				
Q	Non turn washer width	6.4			
R	Spoke hole diameter (mm)	2.9			
S	Spoke hole chamfer	90°			

# EV / Spare Parts List

# Spare parts list

## ALFINE 11-speed Internal Hub SG-S7001-11

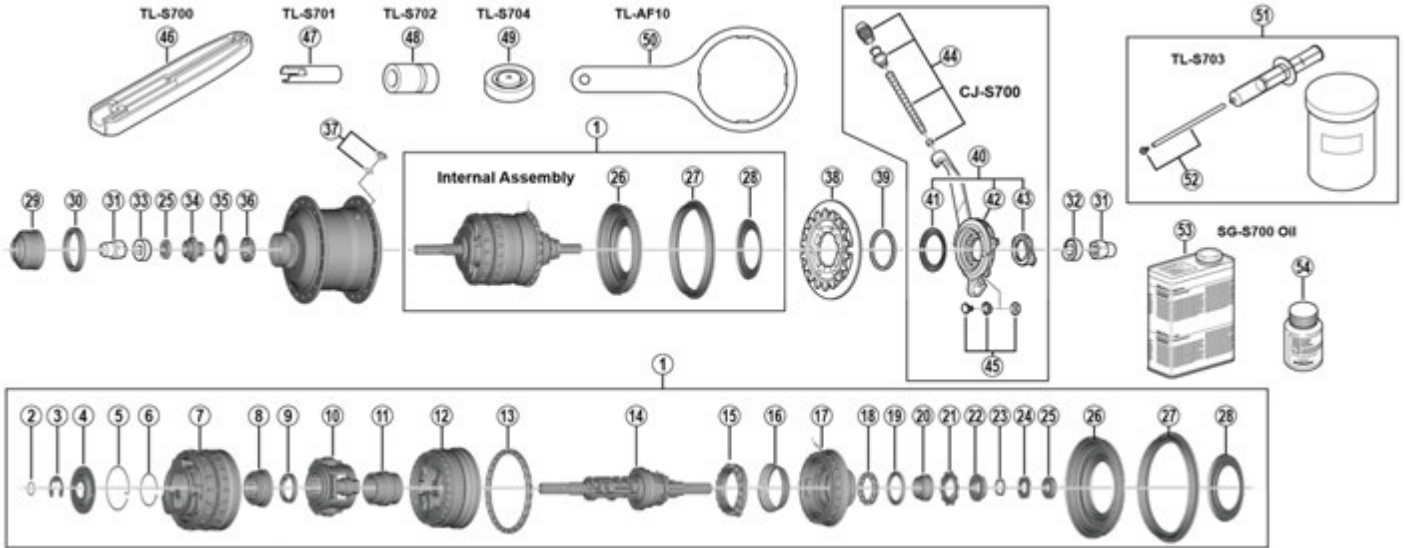

ITEM NO.	SHIMANO CODE NO.	DESCRIPTION
1	Y3EN98010	Internal assembly (axle length 187 mm)
2	Y37E08000	O-ring
3	Y34R79000	Snap ring (diameter 12 mm / 1.0 mm)
4	Y37R78000	Carrier hold plate
5	Y37R80000	Carrier 3 slide spring
6	Y37R81000	Sun Gear 4 slide spring
7	Y37R98020	Carrier 3 unit
8	Y3EN09000	Sun gear 4
9	Y37R56000	Sun gear 3 guide ring
10	Y3EN98020	Carrier 2 unit
11	Y3EN07000	Sun gear 2
12	Y3EN98030	Carrier 1 unit
13	Y37R98050	Ball retainer S (3/16" x 26)
14	Y3EN98040	Hub axle unit (axle length 187 mm)
15	Y3EN98050	Clutch unit
16	Y34R21000	Return spring A
17	Y3EN98060	Driver unit
18	Y34R98070	Ball retainer P (3/16" x 13)
19	Y37R18000	Seal ring R
20	Y37R17000	Right-hand cone
21	Y37R16000	Drive plate seal
22	Y37R98090	Lock washer
23	Y37R15000	Lock washer seal
24	Y37R12000	Joint nut stop washer
25	Y37R11000	Serrated lock nut (4.4 mm)
26	Y37R98100	Right-hand dust cap A with seal
27	Y35Z20000	Chain guard
28	Y37R75000	Right-hand dust cap D
29	Y37R74000	Rotor mount cover
30	Y37R82000	Rotor spacer
31	Y72A01000	Cap nut (3/8")
32	Y33Z20500	Non-turn washer 5R (yellow)
	Y33M39600	Non-turn washer 6R (silver)
	Y33M39700	Non-turn washer 7R (black)
	Y34R85010	Non-turn washer 8R (dark blue)
	Y33M9801T	Non-turn washer 9R (light green)

ITEM NO.	SHIMANO CODE NO.	DESCRIPTION
33	Y33M39510	Non-turn washer 5L (brown)
	Y33M39610	Non-turn washer 6L (white)
	Y33M39710	Non-turn washer 7L (gray)
	Y34R85000	Non-turn washer 8L (dark green)
34	Y33M9802T	Non-turn washer 9L (light brown)
	Y37R98110	Left-hand cone with dust cap
35	Y37R73000	Seal ring L
36	Y36U98030	Ball retainer (7/32" x 9)
37	Y37R98120	Oil port screw (silver) and O-ring
	Y37R98130	Oil port screw (black) and O-ring
38	ICS550018	Sprocket 18T with guard plate (CS-S500)
	ICS550020	Sprocket 20T with guard plate (CS-S500)
39	Y32120100	Snap ring C
40	Y72A98010	CJ-S700 Cassette joint unit
	Y72A98030	CJ-S700 Cassette joint unit for belt drive system
41	Y74Y18000	Driver cap
42	Y72A98020	CJ-S700 Cassette joint
	Y72A98040	CJ-S700 Cassette joint for belt drive system
43	Y33Z98020	Cassette joint fixing ring
44	Y6TV98060	Outer receiver unit
45	Y6TV98070	Inner cable fixing bolt unit
46	Y13098024	TL-S700 Inner cable fixing bolt setting tool
47	Y13098021	TL-S701 Right-hand cone removal tool
48	Y13098022	TL-S702 Right-hand cone installation tool
49	Y70819000	TL-S704 Seal set tool
50	Y32010000	TL-AF10 Right-hand dust cap A installation tool
51	Y13098023	TL-S703 Oil kit
52	Y13098025	Tube set (tube and bleeding nipple)
53	Y13098480	SG-S700 Oil (1 L)
54	Y13098481	SG-S700 Oil (50 ml)

Spare parts list

**ALFINE 11-speed Internal Hub**  
**SG-S7051-11**  
**MU-S705 MU-UR500 MU-UR510**

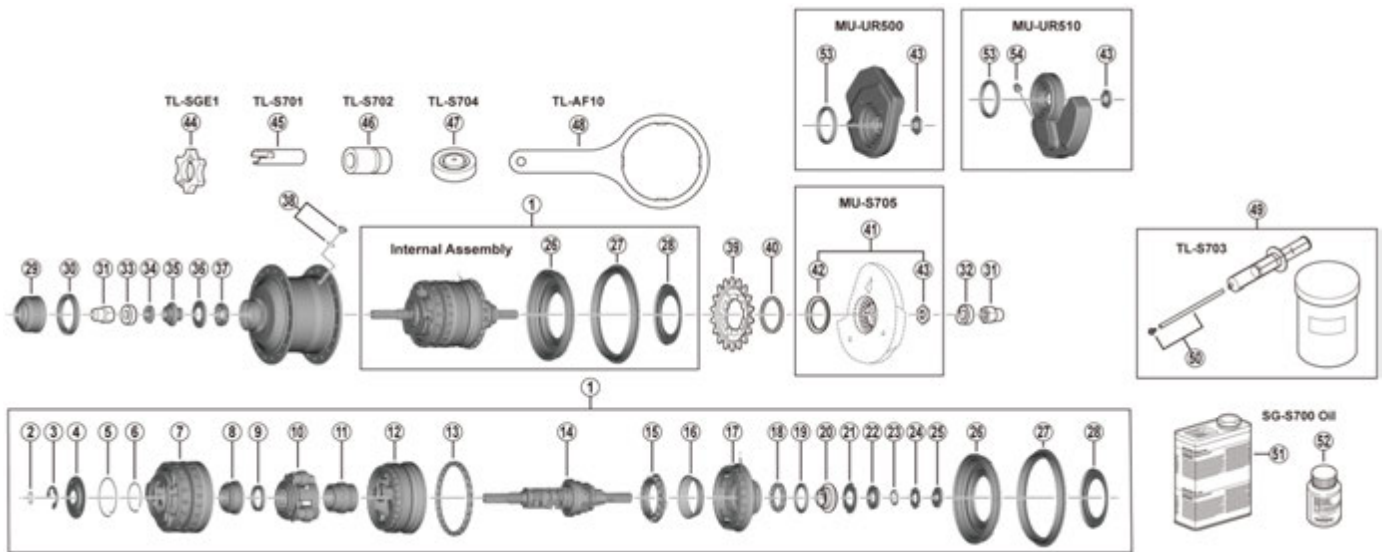

ITEM NO.	SHIMANO CODE NO.	DESCRIPTION
1	Y3EM98010	Internal assembly (axle length 187 mm)
2	Y37E08000	O-ring
3	Y34R79000	Snap ring (diameter 12 mm / 1.0 mm)
4	Y37R78000	Carrier hold plate
5	Y37R80000	Carrier 3 slide spring
6	Y37R81000	Sun gear 4 slide spring
7	Y37R98020	Carrier 3 unit
8	Y3EN09000	Sun gear 4
9	Y37R56000	Sun gear 3 guide ring
10	Y3EN98020	Carrier 2 unit
11	Y3EN07000	Sun gear 2
12	Y3EN98030	Carrier 1 unit
13	Y37R98050	Ball retainer S (3/16" x 26)
14	Y3EM98020	Hub axle unit (axle length 187 mm)
15	Y3EN98050	Clutch unit
16	Y34R21000	Return spring A
17	Y3EN98060	Driver unit
18	Y34R98070	Ball retainer P (3/16" x 13)
19	Y38F06000	Seal ring R
20	Y3EM98030	Right-hand cone with cap
21	Y38F13000	Drive plate seal
22	Y38F98040	Lock washer
23	Y37R15000	Lock washer seal
24	Y38F17000	Right-hand lock nut washer
25	Y38F16000	Right-hand lock nut
26	Y37R98100	Right-hand dust cap A with seal
27	Y35Z20000	Chain guard
28	Y37R75000	Right-hand dust cap D
29	Y37R74000	Rotor mount cover
30	Y37R82000	Rotor spacer
31	Y72A01000	Cap nut (3/8")
32	Y33Z20500	Non-turn washer 5R (yellow)
	Y33M39600	Non-turn washer 6R (silver)
	Y33M39700	Non-turn washer 7R (black)
	Y34R85010	Non-turn washer 8R (dark blue)
	Y33M9801T	Non-turn washer 9R (light green)

ITEM NO.	SHIMANO CODE NO.	DESCRIPTION
33	Y33M39510	Non-turn washer 5L (brown)
	Y33M39610	Non-turn washer 6L (white)
	Y33M39710	Non-turn washer 7L (gray)
	Y34R85000	Non-turn washer 8L (dark green)
	Y33M9802T	Non-turn washer 9L (light brown)
34	Y37R11000	Left-hand serrated lock nut (4.4 mm)
35	Y37R98110	Left-hand cone with dust cap
36	Y37R73000	Seal ring L
37	Y36U98030	Ball retainer (7/32" x 9)
38	Y37R98120	Oil port screw (silver) and O-ring
	Y37R98130	Oil port screw (black) and O-ring
39	ICSS50018X	Sprocket 18T (CS-5500 with out guard)
	ICSS50020X	Sprocket 20T (CS-5500 with out guard)
40	Y32120100	Snap ring C
41	Y38F98050	Motor unit seal and lock nut
42	Y707000G0	Motor unit seal
43	Y707000Y0	Lock nut
44	Y20W10000	TL-SGE1 1st gear set tool
45	Y13098021	TL-S701 Right-hand cone removal tool
46	Y13098022	TL-S702 Right-hand cone installation tool
47	Y70819000	TL-S704 Seal set tool
48	Y32010000	TL-AF10 Right-hand dust cap A installation tool
49	Y13098023	TL-S703 Oil kit
50	Y13098025	Tube set (tube and bleeding nipple)
51	Y13098480	SG-S700 Oil (1 L)
52	Y13098481	SG-S700 Oil (50 ml)
53	Y78U00022	Motor unit seal
54	Y3GK89000	Boot

Specifications are subject to change without notice.