

# SERVICE INSTRUCTIONS

**ST-M090** (4-finger type)  
**ST-M091** (2-finger type)  
**ST-M070** (4-finger type)  
**ST-M071** (2-finger type)

STI

Before use, read these instructions carefully, and follow them for correct use.



SHIMANO AMERICAN CORPORATION  
 One Shimano Drive, Irvine, California, U.S.A. 92718 Tel. (714) 951-5003

SHIMANO (EUROPA) GmbH  
 Kleinhülsen 1-3, 4010 Hilden, West Germany Tel. 02103-5005-0

© Sep. 1989 by Shimano Co., Ltd. T-2A XBC SZK Printed in Japan.

SHIMANO (SINGAPORE) PTE. LTD.  
 No. 20, Bencoolen Sector Jurong Town, Singapore 2262 Tel. 2654777

SHIMANO INDUSTRIAL CO., LTD.  
 3-77 Oimatsucho, Sakai, Osaka, Japan Tel. (0722) 23-3243

## Operation

### Front lever operation

Both lever (a) and lever (b), the lever always returns to the initial position when it is released after shifting.

#### ● To shift from a small chainwheel to a larger chainwheel

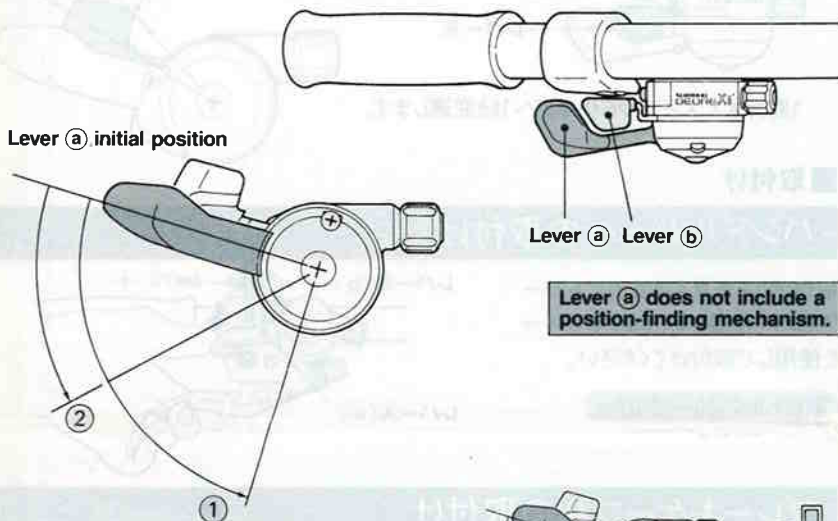

● As shown by ① in the illustration, when the lever is pressed the full stroke there is a shift (of two gears) from the smallest chainwheel to the largest chainwheel.

● As shown by ② in the illustration, when the lever is pressed to the mid-point of a full stroke there is a shift (of one gear) from a small chainwheel to the next larger chainwheel.  
 Example: from the intermediate chainwheel to the largest chainwheel

#### ● To shift from a large chainwheel to a smaller chainwheel

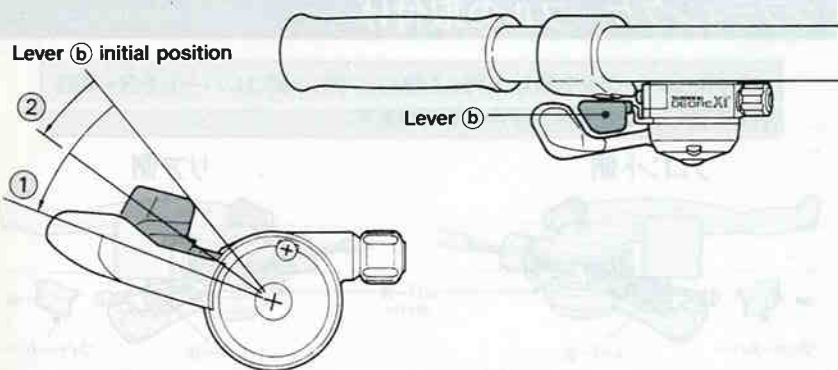

● As shown by ① in the illustration, when the lever is pressed the full stroke there is a shift to the smallest chainwheel. (either from the largest chainwheel to the smallest chainwheel, or from the intermediate chainwheel to the smallest chainwheel)

● ② is for shifting from the one chainwheel to the next chainwheel.

#### ● Noise-prevention mechanism (trimming)

If chain noise occurs, due to overshifting, when a shift is made from the smallest chainwheel to the intermediate chainwheel, the overshifting can be adjusted by gently pressing lever (b) to move the front derailleur slightly toward the small chainwheel, thus activating the noise-prevention mechanism.

### Rear lever operation

For both lever (A) and lever (B), the lever always returns to the initial position when it is released after shifting is finished.

#### ● To shift from a small sprocket to a larger sprocket

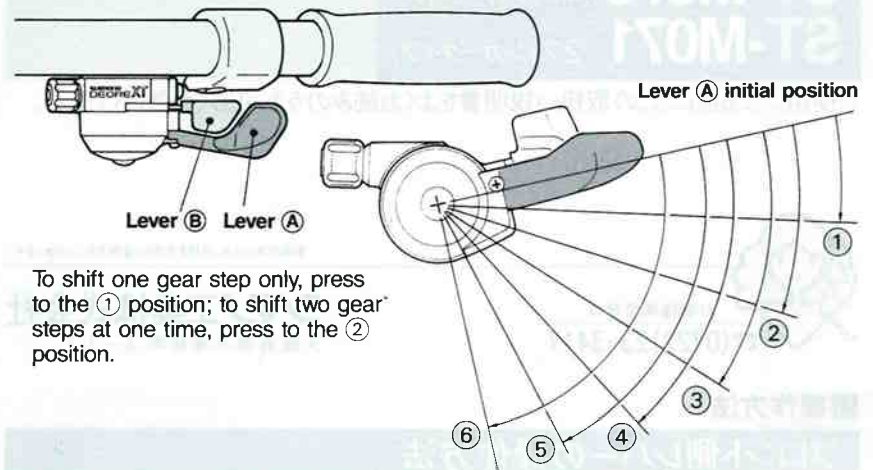

To shift one gear step only, press to the ① position; to shift two gear steps at one time, press to the ② position.

#### ● To shift from a large sprocket to a smaller sprocket

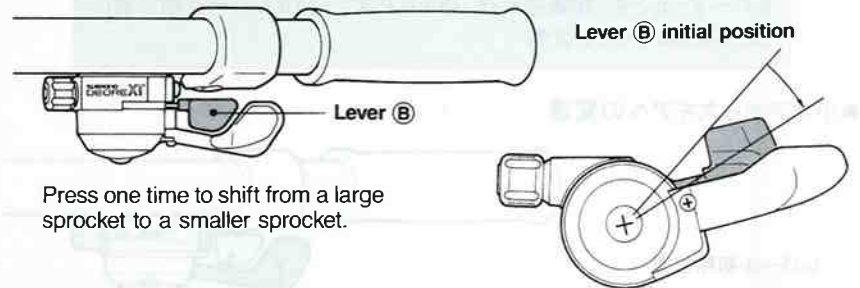

Press one time to shift from a large sprocket to a smaller sprocket.

## Installation

### Installation to the handlebars

Move lever (A) and lever (a) so that the installation bolt can be seen, and then use a 5-mm Allen key to install.

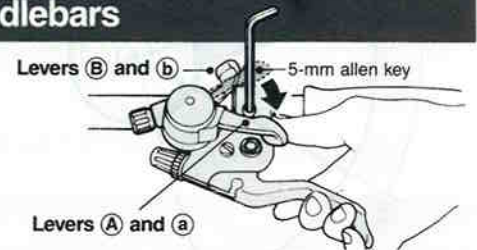

Installation torque:  
 60—80 kgfcm (50—70 in.lbs.)

### Connection of the brake cable

	Inner cable	Outer casing
ST-M090, ST-M091	∅2 mm	∅6 mm
ST-M070, ST-M071	∅1.6 mm	∅5 mm

The "reach" of the lever can be adjusted to any one of four steps by using the reach-adjustment bolt (on the rear side of the lever).

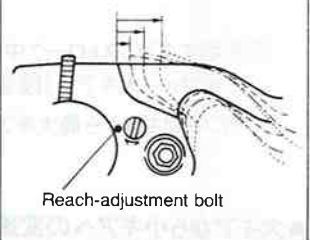
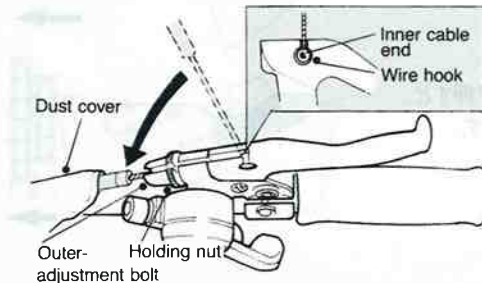

### Connection of the shifting cable

First, for the rear, press lever (B) six times or more, and then, for the front, press lever (b) three or four times. Remove the wire cover, and connect the inner cable.

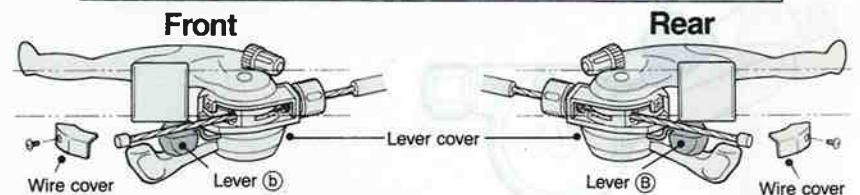

Never remove the lever cover. Do not loosen the lever cover installation bolt.

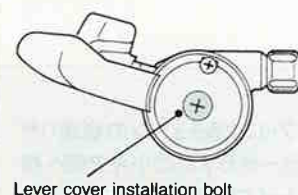

The finger-reach position can be adjusted to any one of three steps. Loosen the lever installation bolt and set to the optimum position.

