

# DURA-ACE & Shimano 600 Ultegra Handle Stem



**DURA-ACE HS-7400**      **SHIMANO 600 ULTEGRA HS-6400**

Before use, read these instructions carefully, and follow them for correct use.

## Handle bar installation

1. Remove the cap, turn the handle bar tightening-adjustment bolt counterclockwise, and then move the push plate downward into the stem until there is a clearance at the handle bar.

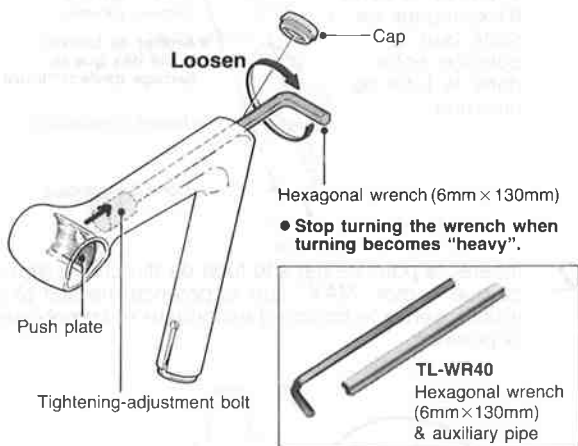

2. Pass the handle bar through the stem, tighten the handle bar tightening-adjustment bolt, and secure the handle bar.

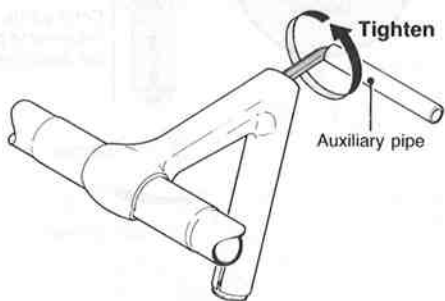

Handle bar tightening-adjustment bolt tightening torque:  
200 ~ 300 kgfcm (175 ~ 260 in.-lbs.)

## Specifications

- Weight: HS-7400.....252g (projection length 100mm)  
HS-6400.....286g (projection length 100mm)
- Handle stem diameter:  $\phi$  22.2 mm,  $\phi$  22.0 mm
- Projection lengths: 70, 80, 90, 100, 110, 120, 130mm
- Appropriate handle bar installation outer diameters: 26.0, 25.4mm

## Notes

- Because the HS-7400 and HS-6400 handle bar installation part outer diameters are exclusively for 26.0 and 25.4mm installation, no other dimensions can be used.
- If the handle stem is removed from the head tube, be sure not to tap the stem head or hexagonal wrench, because the impact of such tapping could cause trouble.
- When the handle bar tightening-adjustment bolt and the expander bolt are turned counterclockwise, stop turning when the turning begins to feel "heavy".

## Installation to the frame

1. Turn the expander bolt counterclockwise, and then move the expander cone so that the stem enters the head tube.

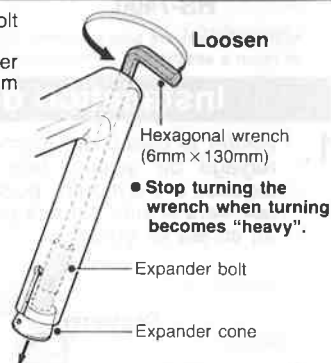

2. Insert the stem into the head tube until the word "MAX" (on the stem) can no longer be seen, tighten the expander bolt, and secure the stem.

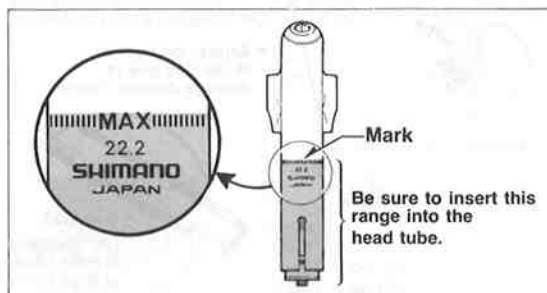

Expander bolt tightening torque:  
200 ~ 300 kgfcm (175 ~ 260 in.-lbs.)

Please note: Specifications are subject to change for improvement without notice. (English)

**SHIMANO AMERICAN CORPORATION**  
One Shimano Drive, Irvine, California U.S.A. 92718 Tel. (714) 951-5003  
**SHIMANO (EUROPA) GmbH.**  
Im Hülsefeld 13 4010 Hilden, West Germany Tel. 02103-5005-0  
**SHIMANO (SINGAPORE) PTE. LTD.**  
No. 20, Benoi Sector, Jurong Town, Singapore 2262 Tel. 2654777  
**SHIMANO INDUSTRIAL CO., LTD.**  
3-77 Oimatsucho, Sakai, Osaka, Japan Tel. (0722) 23-3243