

WARNING

- It is important to completely understand the operation of your bicycle's brake system. Improper use of your bicycle's brake system may result in a loss of control or an accident, which could lead to severe injury. Because each bicycle may handle differently, be sure to learn the proper braking technique (including brake lever pressure and bicycle control characteristics) and operation of your bicycle. This can be done by consulting your professional bicycle dealer and the bicycle's owners manual, and by practicing your riding and braking technique.
- The MC40 brake system is equipped with a power adjuster in the wire hooking unit of the BL-MC40 brake lever which allows the rider to change the relationship between the brake input and output. If this power adjuster is moved, the braking force will be dramatically increased, so that a high level of braking performance can be achieved from only a small amount of lever movement. Accordingly, normal braking operation may cause a greater-than-expected amount of braking force to be applied, which could make the bicycle fall forward, causing serious injury to the rider. To avoid this, please read the following instructions thoroughly before moving the power adjuster.

After changing the power adjuster setting, make sure that you are completely used to the new braking characteristics before riding the bicycle, otherwise the bicycle might fall forward if you have to apply the brakes suddenly, such as when a vehicle appears.

- Without the power adjuster being moved to the "L" position (standard specifications for shipment)

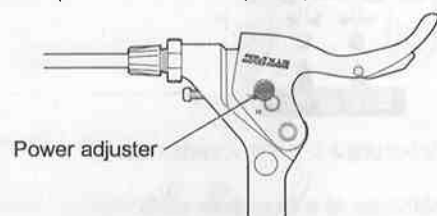

- With the power adjuster moved to the "H" position

An ample degree of braking force can be obtained from a small amount of brake lever input, to provide a high level of brake performance. However, if the brakes are operated suddenly with a normal amount of brake lever input, there is the danger that the bicycle may fall forward. After moving the power adjuster, first ride the bicycle at a speed of less than 6 mph (10 km/h) while applying the brakes repeatedly in order to get a feel for the difference in braking characteristics before riding at higher speeds. Beginners should be particularly careful.

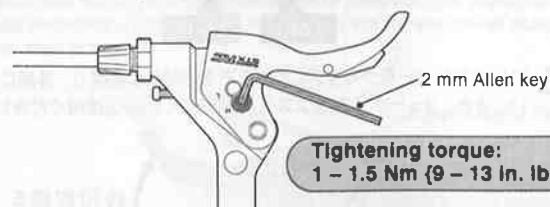

- Use the BR-MC40 V-brake with SERVO WAVE ACTION and adjustable V-brake-compatible levers such as the BL-MC40/BL-M600/BL-M601/BL-M739/BL-M950/ST-M739/ST-M950 brake levers.

- Do not use the BR-MC40 V-brake with mode switching-type brake levers such as the BL-T400/ST-T400/SB-7S45/BL-IM45, as these brake levers are only for use with V-brakes with power modulator, cantilever brakes and roller brakes.

SERVICE INSTRUCTIONS

SI-B520B

Multi-Condition Brake System

Before use, read these instructions carefully, and follow them for correct use.

Multi-Condition Brake System

By providing superior wet weather braking performance (control and modulation), braking performance will not vary in a multitude of conditions when using this brake system.

In order to realize the best performance, we recommend that the following combination be used.

Series	STX-RC
Brake lever	BL-MC40
V-brake	BR-MC40
Brake cable	

NOTE:

- By using these parts as a set, the optimum efficiency of the Multi-Condition Brake System can be realized.
- For any questions regarding methods of handling or maintenance, please contact the place of purchase.

Installation of the brake lever

Use a 5 mm Allen key to install the brake lever.

Tightening torque:
6 - 8 Nm (52 - 69 in. lbs.)

Use a handlebar grip with a maximum outer diameter of 32 mm.

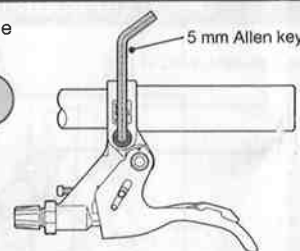

Installing the inner cable

- Slide the inner cable end cover of the brake lever as shown in the illustration.

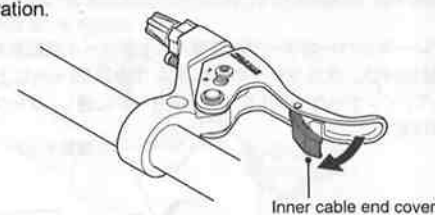

- Pass the inner cable through the inside of the brake lever, and place the inner cable end against the pawl of the brake lever body.

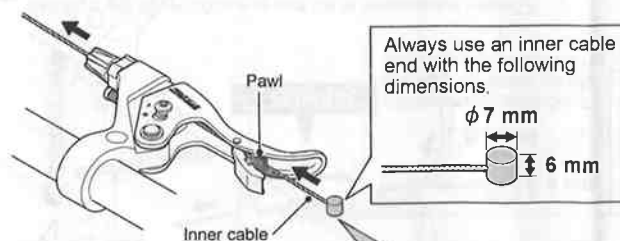

Inner cable end setting direction

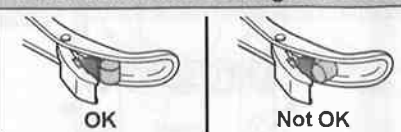

- Return the inner cable end cover to its original position.

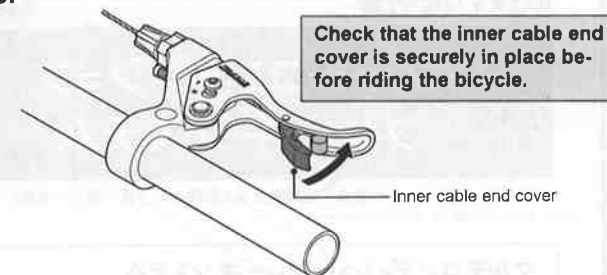

Installation of the V-brake

- Insert the stopper pin of the brake body into the center spring hole in the frame mounting boss, and then secure the brake body to the frame with the link fixing bolt.

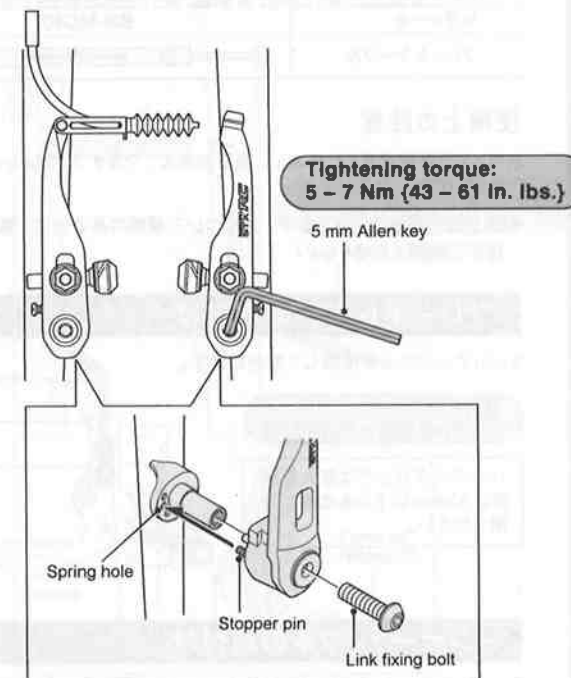

- Turn the cable adjustment bolt of the brake lever 3 - 4 times counterclockwise to loosen it. Next, while keeping the distance A of the brake body at 39 mm or more, pass the inner cable through the inner cable guide and then tighten the cable fixing bolt.

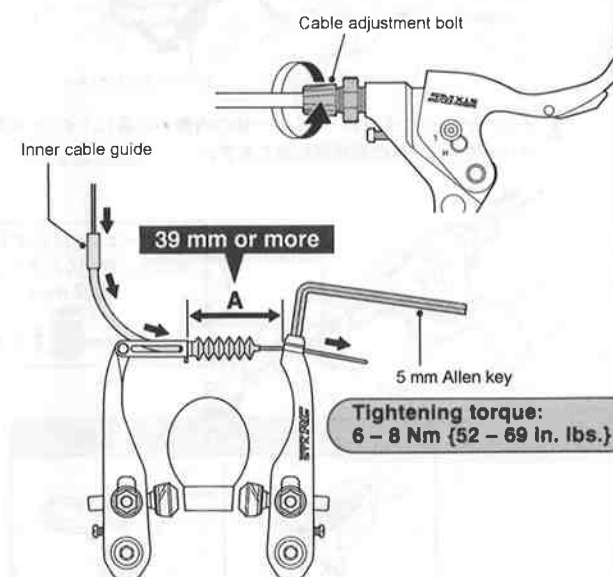

- While holding the shoe against the rim, tighten the shoe fixing nut.

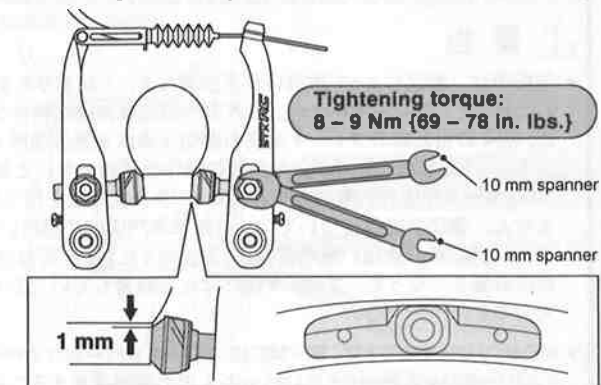

- Tighten the cable adjustment bolt of the brake lever by turning it clockwise until the total of the shoe clearances at left and right equals 2 mm.

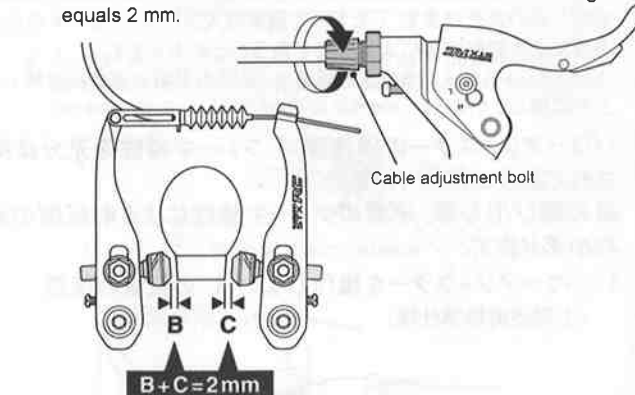

- Adjust the balance with the spring tension adjustment screws.

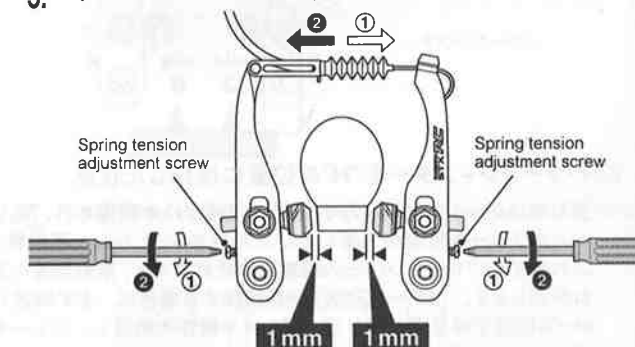

- Depress the brake lever about 10 times as far as the grip and check that everything is operating correctly and that the shoe clearance is correct before using the brakes.

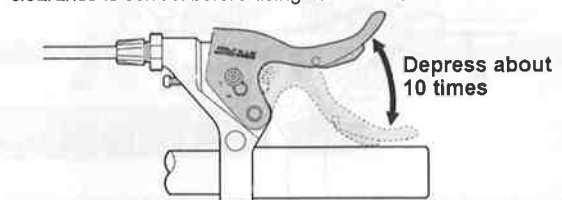

These service instructions explain how to use and maintain the Shimano bicycle parts which have been used on your new bicycle. For any questions regarding your bicycle or other matters which are not related to Shimano parts, please contact the place of purchase or the bicycle manufacturer.

Please note: Specifications are subject to change for improvement without notice. (English)

SHIMANO

SHIMANO AMERICAN CORPORATION
One Shimano Drive, P.O. Box 19615, Irvine, California U.S.A. 92623-9615 Phone 714-951-5003

SHIMANO EUROPA
Industrieweg 24 NL-8071 CT Nunspeet, Holland Phone 31-3412-72222

SHIMANO INC.
3-77 Oimatsucho, Sakai, Osaka, Japan Phone 0722-23-3243

These service instructions are printed on recycled paper and can be recycled again.