

General Safety Information

⚠ WARNING

– To avoid serious injuries:

- It is important to completely understand the operation of your bicycle's brake system. Improper use of your bicycle's brake system may result in a loss of control or an accident, which could lead to severe injury. Because each bicycle may handle differently, be sure to learn the proper braking technique (including brake lever pressure and bicycle control characteristics) and operation of your bicycle. This can be done by consulting your professional bicycle dealer and the bicycle's owners manual, and by practicing your riding and braking technique.
- When securing the brake arm to the frame, be sure to securely tighten the clip screw and clip nut to the specified tightening torque. Use lock nuts with nylon inserts (self-locking nuts) for the clip nut. It is recommended that standard Shimano parts be used for the clip screw, clip nut and brake arm clip. If the clip nut comes off the brake arm, or if the clip screw or brake arm clip becomes damaged, the brake arm may rotate on the chainstay and cause the handlebars to jerk suddenly, or the bicycle wheel may lock and the bicycle may fall over, causing serious injury.
- Obtain and read the service instructions carefully prior to installing the parts. Loose, worn, or damaged parts may cause serious injury to the rider. We strongly recommend only using genuine Shimano replacement parts.
- Read these Technical Service Instructions carefully, and keep them in a safe place for later reference.

⚠ CAUTION

– To avoid serious injuries:

- The Shimano Inter-M brake system cannot be used with mountain bikes. If you try to use it with mountain bikes, hard braking operation will cause the internal brake parts to become very hot, and this may weaken braking performance. It may also cause a reduction in the amount of brake grease inside the brake, and this can lead to problems such as abnormally sudden braking.
- If any of the following occur while using the brakes, stop riding immediately and ask the place of purchase to carry out inspection and repairs.
 - If abnormal noise is heard when the brakes are applied
 - If braking force is abnormally strong
 - If braking force is abnormally weak

In the case of 1) and 2), the cause might be not enough brake grease, so ask the place of purchase to grease the mechanism with special roller brake grease.
- In order to get the best performance from the Shimano Inter-M brake, be sure to use Shimano brakes cables and brake levers as a set.

(The amount of movement of the inner cable must be 14.5 mm or more when the brake lever is depressed. If it is less than 14.5 mm, braking performance will suffer, and the brakes may fail to work.)
- Check that the brake unit is firmly secured to the hub with the brake unit fixing nut or the brake unit fixing washer.

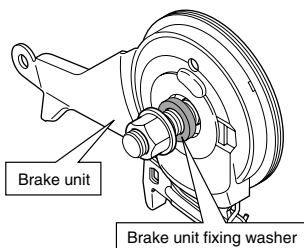

- When using the brake unit fixing nut: Tightening torque: 20 – 25 N·m {174 – 218 in. lbs.}
- When using the brake unit fixing washer: Manual insertion

- Check that the brake arm is securely fastened to the chainstay by the brake arm clip. If it is not installed correctly, braking performance will suffer.

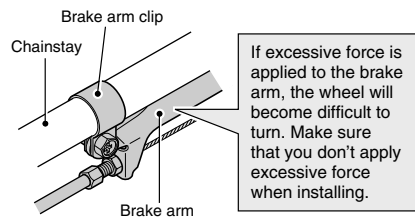

- If the brakes are used frequently, the area around the brake may become hot. Do not touch the area around the brake for at least 30 minutes after you finish riding the bicycle.

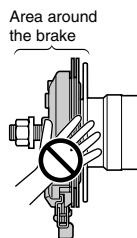

- If the brake cable becomes rusted, braking performance will suffer. If this happens, replace the brake cable with a genuine Shimano brake cable and re-check the braking performance.
- The brake unit should never be disassembled. If it is disassembled, it will no longer work properly.

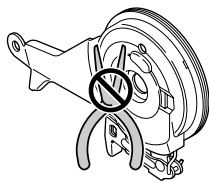

NOTE:

- The Inter-M brake is different from conventional brakes in that the inside of the brake drum is filled with grease. This may cause the turning of the wheel to be slightly heavier than usual, particularly in cold weather.
- For maximum performance we highly recommend Shimano lubricants and maintenance products.
- For any questions regarding methods of handling or adjustment, please contact the place of purchase.

SI-75A0A-002

BR-IM31-R
BR-IM35-RF Inter-M Brake

Technical Service Instruction

SHIMANO
NEXUS
INTER-M

Installation of the Inter-M brake

- After setting the hub onto the frame, install the brake arm of the Inter-M brake to the chainstay with the brake arm clip, provisionally tighten the clip screw and clip nut, and then tighten the brake unit fixing nut.

Note:

If the brake arm is in the incorrect position as shown in the illustration so that it cannot be provisionally installed to the chainstay, loosen the brake unit fixing nut and turn the brake arm. Then, after provisionally securing the brake arm to the chainstay, tighten the brake unit fixing nut.

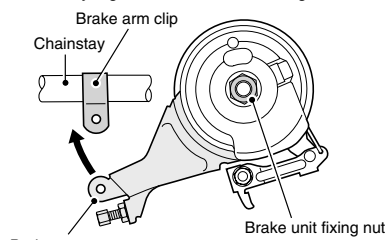

Tightening torque:
20 – 25 N·m {174 – 218 in. lbs.}

Note:

When using the brake unit fixing washer instead of the brake unit fixing nut, insert the washer into the hub axle by hand to secure the brake.

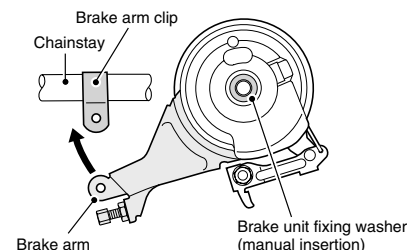

- After securing the hub to the frame with the hub nuts, fix the brake arm of the Inter-M brake securely to the chainstay with the brake arm clip.

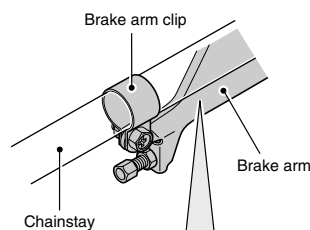

If excessive force is applied to the brake arm, the wheel will become difficult to turn. Make sure that you don't apply excessive force when installing.

Note:

- When installing the brake arm clip, securely tighten the clip screw while holding the clip nut with a 10 mm spanner.

Tightening torque:
2 – 3 N·m {17 – 26 in. lbs.}

- After installing the brake arm clip, check that the clip screw protrudes about 4 mm from the surface of the clip nut.

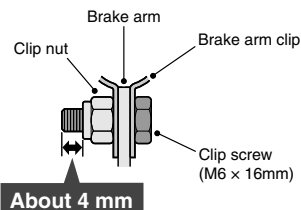

About 4 mm

Installing the brake cable

- Place the cable adjusting bolt so that it is 15 – 17 mm from the end of the brake arm, and then pass the inner cable through the cable adjusting bolt of the brake arm and then through the hole in the inner cable fixing bolt.

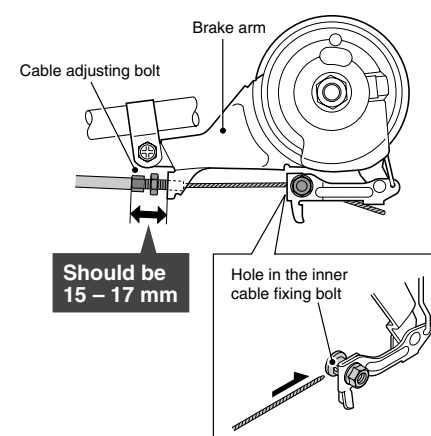

- Check that both ends of the outer casing are securely inserted into the cable adjusting bolts of both the brake lever and brake arm.

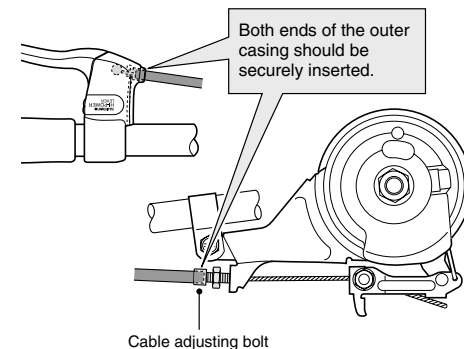

- Pull the link back until it stops. Then, while pulling the inner cable to apply the full amount of tension to the cable, tighten the inner cable fixing nut.

Tightening torque:
6 – 8 N·m {52 – 70 in. lbs.}

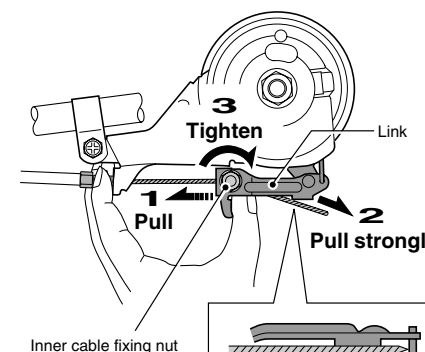

Note:
Set the inner cable so that it passes below the link.

Adjusting the brake cable

- After checking that the wheel does not easily turn while the brake cable is being pulled, depress the brake lever about 10 times as far as the grip in order to run in the brake cable.

Depress about 10 times

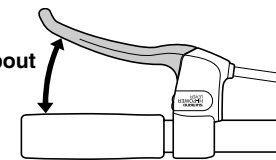

Note:

If the brake cable is not run in, it will need to be adjusted again after only a short period of use.

- Turn the cable adjusting bolt so that there is about 15 mm of play in the brake lever.

(The amount of brake lever play is the distance from the position where the brake lever is not operated to the position where a force is felt suddenly when the brake lever is pulled.)

15 mm of play

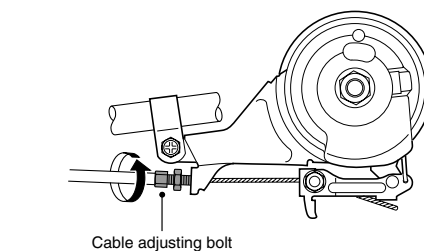
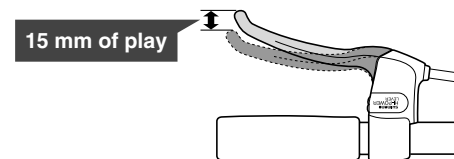

- After depressing the brake lever to check the braking performance, secure the cable adjusting bolt with the cable adjusting nut.

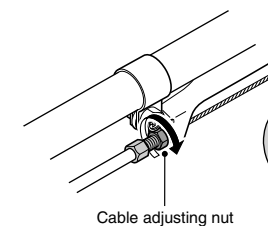

Tightening torque:
1 – 2 N·m
{9 – 17 in. lbs.}

These service instructions explain how to use and maintain the Shimano bicycle parts which have been used on your new bicycle. For any questions regarding your bicycle or other matters which are not related to Shimano parts, please contact the place of purchase or the bicycle manufacturer.

* Service Instructions in further languages are available at:
<http://techdocs.shimano.com>

Please note: Specifications are subject to change for improvement without notice. (English)

SHIMANO

SHIMANO AMERICAN CORPORATION
One Holland, Irvine, California 92618, U.S.A. Phone: +1-949-951-5003

SHIMANO EUROPE B.V.
Industrieweg 24, 8071 CT Nunspeet, The Netherlands Phone: +31-341-272222

SHIMANO INC.
3-77 Oimatsu-cho, Sakai-ku, Sakai-shi, Osaka 590-8577, Japan

© Sep. 2011 by Shimano Inc. AWS. Printed in China