

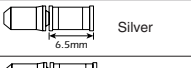

WARNING

“Maintenance interval depends on the usage and riding circumstances. Clean regularly the chain with an appropriate chaincleaner. Never use alkali based or acid based solvents such as rust cleaners. If those solvent be used chain might break and cause serious injury.”

- Use the reinforced connecting pin only for connecting the narrow type of chain.
- There are two different types of reinforced connecting pins available. Be sure to check the table below before selecting which pin to use. If connecting pins other than reinforced connecting pins are used, or if a reinforced connecting pin or tool which is not suitable for the type of chain is used, sufficient connection force may not be obtained, which could cause the chain to break or fall off.

Chain	Reinforced connecting pin	Chain tool
9-speed super narrow chain such as CN-7701 / CN-HG93	 Silver	TL-CN32 / TL-CN27
8-/7-/6-speed narrow chain such as CN-HG50 / CN-HG40	 Black	TL-CN32 / TL-CN27

- If it is necessary to adjust the length of the chain due to a change in the number of sprocket teeth, make the cut at some other place than the place where the chain has been joined using a reinforced connecting pin or an end pin. The chain will be damaged if it is cut at a place where it has been joined with a reinforced connecting pin or an end pin.
- Be careful not to let the cuffs of your clothes get caught in the chain while riding, otherwise you may fall off the bicycle.
- Check that the tension of the chain is correct and that the chain is not damaged. If the tension is too weak or the chain is damaged, the chain should be replaced. If this is not done, the chain may break and cause serious injury.
- It is important to periodically check the tightening torques for the crank arms and pedals. After riding approximately 100 km (60 miles), re-check the tightening torques. If the tightening torques are too weak, the crank arms or pedals may come off and the bicycle may fall over, and serious injury may occur as a result.
- Check that there are no cracks in the crank arms before riding the bicycle. If there are any cracks, the crank arm may break and you may fall off the bicycle.
- Obtain and read the service instructions carefully prior to installing the parts. Loose, worn or damaged parts may cause the bicycle to fall over and serious injury may occur as a result. We strongly recommend only using genuine Shimano replacement parts.
- Obtain and read the service instructions carefully prior to installing the parts. If adjustments are not carried out correctly, the chain may come off and this may cause you to fall off the bicycle which could result in serious injury.
- Read these Technical Service Instructions carefully, and keep them in a safe place for later reference.

CAUTION

- If the chain is on the smallest or intermediate chainring, there is the danger of injury from the tips of the teeth on the largest chainring.

Note

- In addition, if pedaling performance does not feel normal, check this once more.
- Before riding the bicycle, check that there is no play or looseness in the connection. Also, be sure to retighten the crank arms and pedals at periodic intervals.
- When installing the pedals, apply a small amount of grease to the threads to prevent the pedals from sticking. Use a torque wrench to securely tighten the pedals. Tightening torque: 35 - 55 N·m (305 - 479 in. lbs.). The right-hand crank arm has a right-hand thread, and the left-hand crank arm has a left-hand thread.
- Do not wash the bottom bracket with high-pressure jets of water.
- If you feel any looseness in the bottom bracket axle, the bottom bracket should be replaced.
- If gear shifting operations do not feel smooth, wash the derailleur and lubricate all moving parts.
- If the amount of looseness in the links is so great that adjustment is not possible, you should replace the derailleur.
- You should periodically wash the chainrings in a neutral detergent and then lubricate them again. In addition, cleaning the chain with neutral detergent and lubricating it can be an effective way of extending the useful life of the chainrings and the chain.
- The cuffs of your clothing may get dirty from the chain while riding.
- If the chain keeps coming off the chainrings during use, replace the chainrings and the chain.
- Apply grease to the bottom bracket before installing it.
- For smooth operation, use the specified outer casing and the bottom bracket cable guide.
- This front derailleur is for triple front chainwheel use only. It cannot be used with the double front chainwheel, as the shifting points do not match.
- When installing the top route type, choose a frame that has three outer casing holders as shown in the illustration at right.
- Use an outer casing which still has some length to spare even when the handlebars are turned all the way to both sides. Furthermore, check that the shifting lever does not touch the bicycle frame when the handlebars are turned all the way.
- Grease the inner cable and the inside of the outer casing before use to ensure that they slide properly.
- Operation of the levers related to gear shifting should be made only when the front chainwheel is turning.
- Parts are not guaranteed against natural wear or deterioration resulting from normal use.
- For maximum performance we highly recommend Shimano lubricants and maintenance products
- For any questions regarding methods of installation, adjustment, maintenance or operation, please contact a professional bicycle dealer.

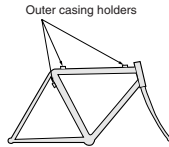
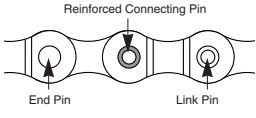

Technical Service Instructions

SI-6UEFA-001

Front Drive System

This service instruction explains how to use and maintain the Shimano bicycle parts which have been used on your new bicycle. For any questions regarding your bicycle or other matters which are not related to Shimano parts, please contact the place of purchase or the bicycle manufacturer.

SHIMANO

SHIMANO AMERICAN CORPORATION
 One Holland, Irvine, California 92618, U.S.A. Phone: +1-949-951-5003

SHIMANO EUROPE B.V.
 Industrieweg 24, 8071 CT Nunspeet, The Netherlands Phone: +31-341-272222

SHIMANO INC.
 3-77 Oimatsu-cho, Sakai-ku, Sakai-shi, Osaka 590-8577, Japan

* Service Instructions in further languages are available at : <http://techdocs.shimano.com>

Please note: specifications are subject to change for improvement without notice. (English) © Dec. 2010 by Shimano Inc. XBC IZM Printed in Singapore.

In order to realize the best performance, we recommend that the following combination be used.

Gears	SIS 8-gears		SIS 7-gears	
	Right	Left	SIS 3-gears	SIS 3-gears
Rapidfire Plus				ST-EF65
Outer casing				OT-SP40
Front derailleur				FD-M360 / M311 / M190A / M190 / M191
Front chainwheel				FC-M311 / M171 / M131
Bottom bracket				BB-UN26 (K)
Chain				CN-HG50 / CN-HG40
Bottom bracket cable guide				SM-SP18 / SM-BT18

Specifications

Front Derailleur	X = Available				
	FD-M360	FD-M311	FD-M190A	FD-M190	FD-M191
Model number					
Applicable to both normal type and top route type	X	X	X	X	X
TOP SWING	X	-	X	X	X
Applicable front chainwheel	FC-M311		FC-M171 / M131		
Top gear tooth	42T / 48T	42T / 48T	42T	42T	48T
Front chainwheel tooth difference	20T	20T	18T	18T	20T
Min. difference between top and intermediate	10T	10T	8T	8T	10T
Front derailleur installation band diameter	S, M, L				
Chainstay angle (α)	63° - 66° / 66° - 69°		66° - 69°		63° - 66° / 66° - 69°
Applicable bottom bracket	BB-UN26 (K)				
Applicable chain line	47.5 / 50 mm				

Installation band diameters: S [28.6 mm], M [31.8 mm], L [34.9 mm] (Use the adapter for S and M sizes.)

Chainwheel

Model number	FC-M311		FC-M171 / M131	
	Chainwheel tooth combination	42-32-22T	48-38-28T	42-34-24T
Crank arm length	170 / 175 mm		170 / 175 mm	
Pedal thread dimensions	BC 9/16" x 20 T.P.I.			

Bottom Bracket

Model number	BB-UN26 (K)		
	Stamped marking	LL123	D-NL K
Spindle length	122.5 mm		
Chain line	50 mm	47.5 mm + t*	47.5 mm
Applicable front chainwheel	FC-M311	FC-M171 / M131	
Thread dimensions	BC 1.37" X 24 T.P.I. (68, 73 mm)		

* t = Chain case thickness (1.5 - 2.1 mm)

Gear shifting operation

Both lever (A) and lever (B) always return to the initial position when they are released after shifting. When operating one of the levers, always be sure to turn the crank arm at the same time.

To shift from a small chainring to a larger chainring (Lever A)

When lever (A) is pressed once, there is a shift of one step from a small chainring to a larger chainring.

Example: from intermediate chainring to largest chainring.

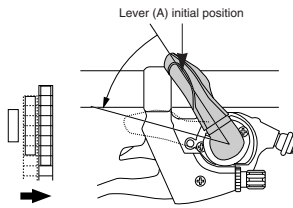

To shift from a large chainring to a smaller chainring (Lever B)

When lever (B) is pressed once, there is a shift of one step from a large chainring to a smaller chainring.

Example: from largest chainring to intermediate chainring.

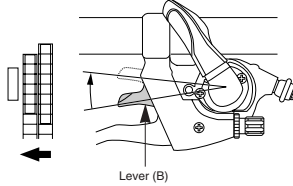

Chain length

Add 2 links (with the chain on both the largest sprocket and the largest chainring)

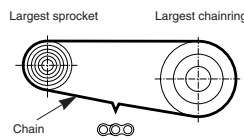

Installation of the Front Derailleur, Bottom Bracket and Front Chainwheel

Use the special tools (TL-UN65 and TL-UN74-S) to install the bottom bracket ① and the front derailleur so that they face as shown in the illustration. Install the adapter ②, and then use the cotterless crank extractor (TL-FC10) to install the front chainwheel.

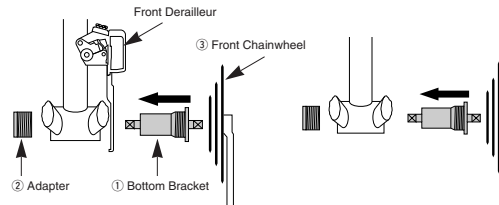

Adapter / bottom bracket tightening torque: 50 - 70 N·m (435 - 608 in. lbs.)
 Front chainwheel tightening torque: 35 - 50 N·m (305 - 435 in. lbs.)

Adjust and then install the front derailleur as shown in the illustration. Do not remove the Pro-Set alignment block at this time.

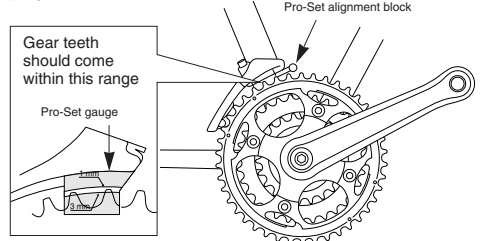

The level section of the chain guide outer plate should be directly above and parallel to the largest chainring. Secure using a 5 mm Allen key.

Tightening torque : 5 - 7 N·m (44 - 60 in. lbs.)

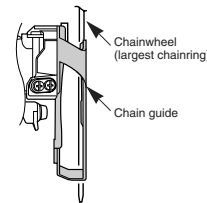

Installation of the shifting lever

Use a handlebar grip with a maximum outer diameter of 32 mm.

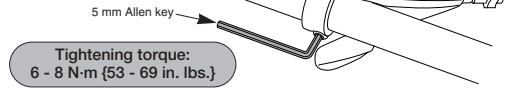

Tightening torque: 6 - 8 N·m (53 - 69 in. lbs.)

SIS adjustment

Be sure to follow the sequence described below.

1. Low adjustment

First remove the Pro-Set alignment block. Next, set so that the clearance between the chain guide inner plate and the chain is 0-0.5 mm.

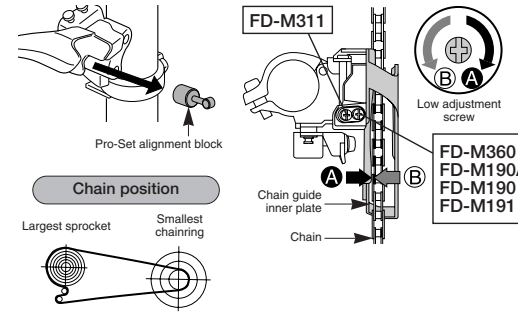

2. Securing the inner cable

Operate lever (B) two times or more to set the lever to the lowest position. Remove the screw, and then remove the cover. Pull out the inner cable as shown in Figure, and then install the new inner cable.

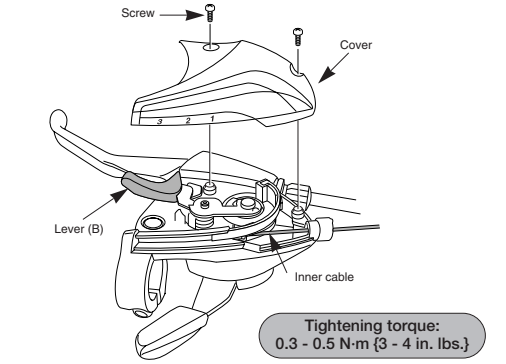

Inserting the inner cable

Insert the inner cable into the outer casing from the end with the marking on it. Apply grease from the end with the marking in order to maintain cable operating efficiency.

Cutting the outer casing

When cutting the outer casing, cut the opposite end to the end with the marking. After cutting the outer casing, make the end round so that the inside of the hole has a uniform diameter.

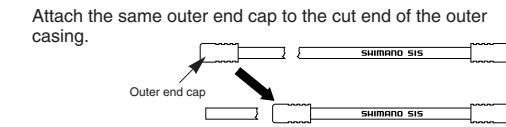

Cut off the excess length of inner cable and then install the inner end cap.

< FD-M311 >

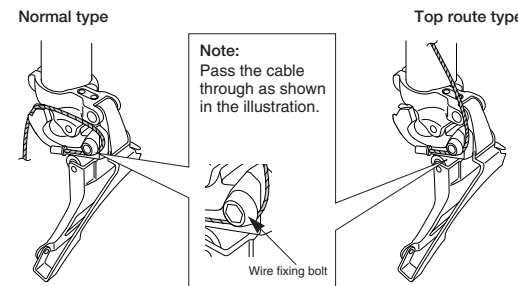

< FD-M360 / M190A / M190 / M191 >

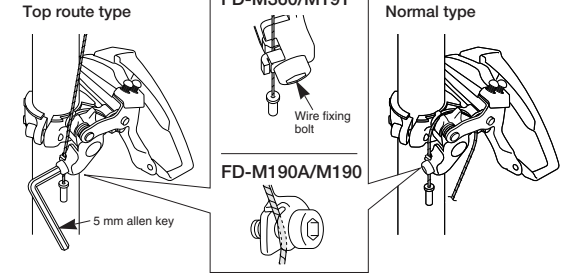

Tightening torque: 5 - 7 N·m (44 - 60 in. lbs.)

Note: Pass the cable through as shown in the illustration.

After taking up the initial slack in the cable, re-secure to the front derailleur as shown in the illustration.

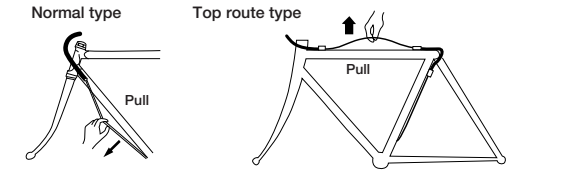

3. Top adjustment

Set so that the clearance between the chain guide outer plate and the chain is 0-0.5 mm.

Chain position

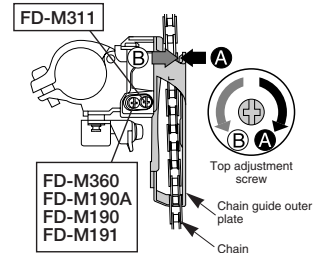
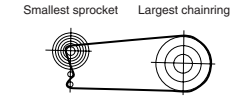

4. Adjustment of the intermediate chainring

When carrying out adjustment, set the chain to the largest sprocket, and at the front, set the chain to the intermediate chainring. Adjust using the outer casing adjustment barrel so that the clearance between the chain guide inner plate and the chain is 0-0.5 mm.

Chain position

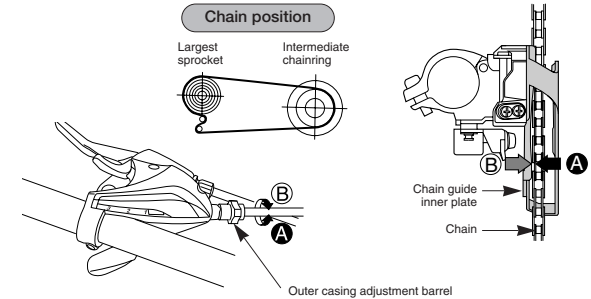
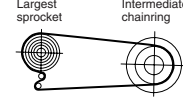

5. Troubleshooting chart

After completion of steps 1 - 4, move the shifting lever to check the shifting. (This also applies if shifting becomes difficult during use.)

If the chain falls to the crank side.	Tighten the top adjustment screw clockwise (about 1/4 turn).
If shifting is difficult from the intermediate chainring to the largest chainring.	Loosen the top adjustment screw counterclockwise (about 1/8 turn).
If shifting is difficult from the intermediate chainring to the smallest chainring.	Loosen the low adjustment screw counterclockwise (about 1/4 turn).
If there is interference between the chain and the front derailleur inner plate at the largest chainring.	Tighten the top adjustment screw clockwise (about 1/8 turn).
If there is interference between the chain and the front derailleur outer plate at the largest chainring.	Loosen the top adjustment screw counterclockwise (about 1/8 turn).
If the intermediate chainring is skipped when shifting from the largest chainring.	Loosen the outer casing adjustment barrel counterclockwise (1 or 2 turns).
If there is interference between the chain and front derailleur inner plate when the rear sprocket is shifted to the largest sprocket when the chainwheel is at the intermediate chainring position.	Tighten the outer casing adjustment barrel clockwise (1 or 2 turns).
If the chain falls to the bottom bracket side.	Tighten the low adjustment screw clockwise (about 1/2 turn).