

General Safety Information

⚠ WARNING

- Obtain, read and carefully service instructions when installing parts. A loose, worn, or damaged parts may cause injury to the rider. We strongly recommend that only genuine Shimano replacement parts be used.
- Be careful not to let the cuffs of your clothes get caught in the chain while riding, otherwise you may fall off the bicycle.
- Read these Technical Service Instructions carefully, and keep them in a safe place for later reference.

Note

- If gear shifting operations cannot be carried out smoothly, clean the derailleur and lubricate all moving parts.
- If the amount of looseness in the links is so great that adjustment is not possible, you should replace the derailleur.
- When the chain is in the position shown in the illustration, the chain may contact the front chainrings or front derailleur and generate noise. If the noise is a problem, shift the chain onto the next-larger rear sprocket or the one after.

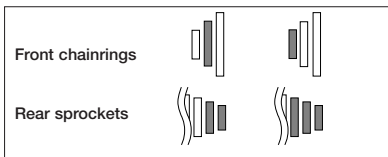

- If attaching the FD-2203 (brazed-on type) to a seat tube with a thickness of more than 31.8 mm, the derailleur may come into contact with the seat tube and interfere with normal gear shifting performance.
- For smooth operation, always be sure to use the specified outer casing and the bottom bracket cable guide.
- Grease the inner cable and the inside of the outer casing before use to ensure that they slide properly.
- This front derailleur is for triple front chainwheel use only. It cannot be used with the double front chainwheel, as the shifting points do not match.
- For the chain, be sure to use only the Shimano narrow type chain. The wide type chain cannot be used.
- Parts are not guaranteed against natural wear or deterioration resulting from normal use.
- For maximum performance we highly recommend Shimano lubricants and maintenance products.
- For any questions regarding methods of installation, adjustment, maintenance or operation, please contact a professional bicycle dealer.

Technical Service Instructions

SI-5GF0B-001

FD-2203

Front derailleur

In order to realize the best performance, we recommend that the following combination be used.

Shifting lever	ST-3303
Outer casing	SP40
Gears	24
Front derailleur	FD-2203
Front chainwheel	FC-2203
Bottom bracket	BB-UN25 (113mm)
Rear derailleur	RD-2200
Freehub	FH-2200
Cassette sprocket	CS-HG50-8
Chain	CN-HG50
Bottom bracket cable guide	SM-SP17

Specifications

Type	Band type / Brazed on type
Front chainwheel tooth difference	22 teeth or less
Min. difference between top and intermediate	10T
Front derailleur installation band diameter	S (28.6mm), M (31.8mm)
Chainstay angle (α)	63° - 66°
Chain line	45mm

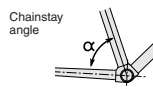

Installation of the front derailleur

Adjust and then install the front derailleur as shown in the illustration. Do not remove the Pro-Set alignment block at this time.

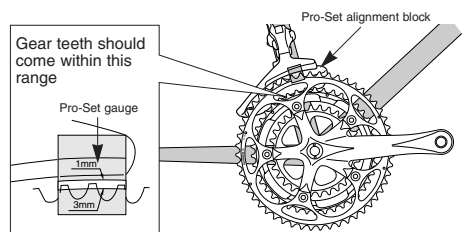

The level section of the chain guide outer plate should be directly above and parallel to the largest chainring. Secure using a 5mm Allen key.

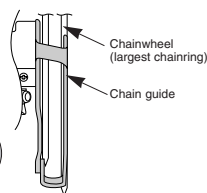

Tightening torque:
5 - 7 N·m
{44 - 60 in. lbs.}

SIS adjustment

Be sure to follow the sequence described below.

1. Low adjustment

First remove the Pro-Set alignment block. Next, set so that the clearance between the chain guide inner plate and the chain is 0 - 0.5 mm.

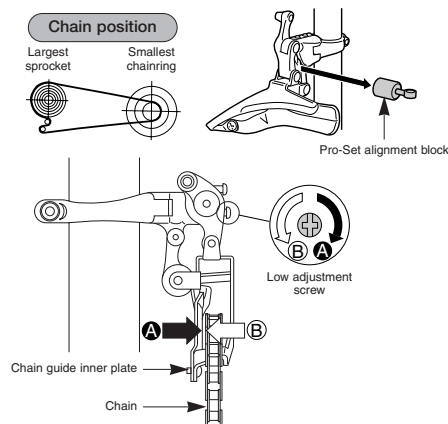

2. Connection and securing of cable

While pulling the inner cable, tighten the wire fixing bolt with a 5 mm allen key to secure the cable.

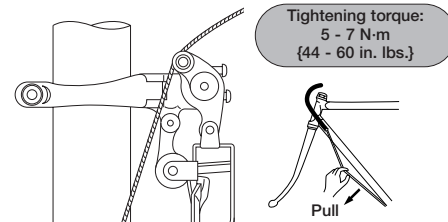

After taking up the initial slack in the cable, re-secure to the front derailleur as shown in the illustration.

3. Top adjustment

Set so that the clearance between the chain guide outer plate and the chain is 0-0.5 mm.

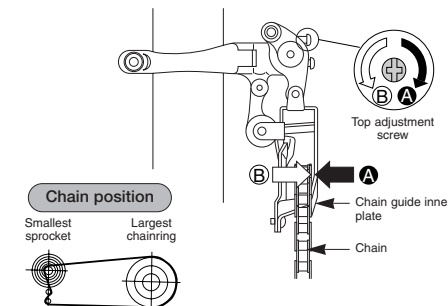

4. Cable adjustment using the intermediate chainring

When making the cable adjustment, place the chain on the largest sprocket for the rear and the middle chainring for the front. Adjust the cable tension by using the outer adjustment barrel so that the clearance between the chain guide inner plate and the chain is 0 - 0.5 mm.

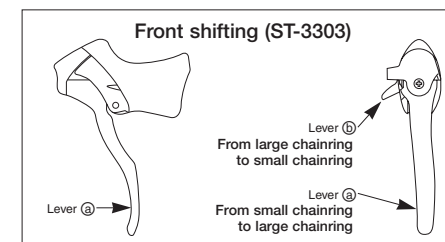
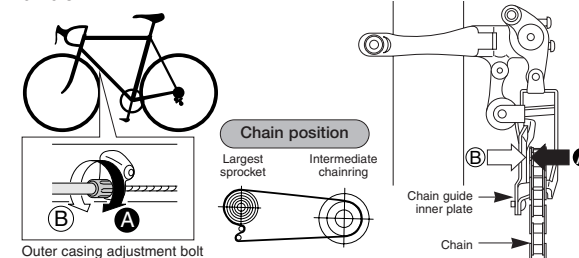

5. Troubleshooting chart

After completion of steps 1 - 4, move the shifting lever to check the shifting. (This also applies if shifting becomes difficult during use.)

If the chain falls to the crank side	Tighten the top adjustment screw clockwise (about 1/4 turn).
If shifting is difficult from the intermediate chainring to the largest chainring	Loosen the top adjustment screw counterclockwise (about 1/8 turn).
If shifting is difficult from the intermediate chainring to the smallest chainring	Loosen the low adjustment screw counterclockwise (about 1/4 turn).
If there is interference between the chain and the front derailleur inner plate at the largest chainring	Tighten the top adjustment screw clockwise (about 1/8 turn).
If there is interference between the chain and the front derailleur outer plate at the largest chainring	Loosen the top adjustment screw counterclockwise (about 1/8 turn).
If the intermediate chainring is skipped when shifting from the largest chainring	Loosen the outer casing adjustment barrel counterclockwise (1 or 2 turns).
If there is interference between the chain and front derailleur inner plate when the rear sprocket is shifted to the largest sprocket when the chainwheel is at the intermediate chainring position.	Tighten the outer casing adjustment barrel clockwise (1 or 2 turns).
If the chain falls to the bottom bracket side.	Tighten the low adjustment screw clockwise (about 1/2 turn).

Be sure to read these service instructions in conjunction with the service instructions for the ST-3303 before use.

SHIMANO

SHIMANO AMERICAN CORPORATION
One Holland, Irvine, California 92618, U.S.A. Phone: +1-949-951-5003

SHIMANO EUROPE B.V.
Industrieweg 24, 8071 CT Nunspeet, The Netherlands Phone: +31-341-272222

SHIMANO INC.
3-77 Oimatsu-cho, Sakai-ku, Sakai-shi, Osaka 590-8577, Jpn

Please note: specifications are subject to change for improvement without notice. (English)
© Jul. 2007 by Shimano Inc. XBC SZK Printed in Singapore.