

General Safety Information

WARNING – To avoid serious injuries:

- It is important to completely understand the operation of your bicycle's brake system. Improper use of your bicycle's brake system may result in a loss of control or an accident, which could lead to severe injury. Because each bicycle may handle differently, be sure to learn the proper braking technique (including brake lever pressure and bicycle control characteristics) and operation of your bicycle. This can be done by consulting your professional bicycle dealer and the bicycle's owners manual, and by practicing your riding and braking technique.
- When securing the brake arm to the frame, be sure to use a brake arm clip that matches the size of the chainstay, and securely tighten them with the clip screw and clip nut to the specified tightening torque. Use a lock nut with a nylon insert (self-locking nut) for the clip nut. It is recommended that standard Shimano parts be used for the clip screw, clip nut and brake arm clip. In addition, use a brake arm clip that matches the size of the chainstay. If the clip nut comes off the brake arm, or if the clip screw or brake arm clip becomes damaged, the brake arm may rotate on the chainstay and cause the handlebars to jerk suddenly, or the bicycle wheel may lock and the bicycle may fall over, causing serious injury.
- Obtain and read the service instructions carefully prior to installing the parts. Loose, worn, or damaged parts may cause serious injury to the rider. We strongly recommend only using genuine Shimano replacement parts.
- Check that the wheels are fastened securely before riding the bicycle. If the wheels are loose in any way, they may come off the bicycle and serious injury may result.
- Read these Technical Service Instructions carefully, and keep them in a safe place for later reference.

CAUTION – To avoid serious injuries:

- The Shimano Inter-M brake system cannot be used with mountain bikes. Furthermore, when using this brake system with other kinds of bikes, avoid continuous application of the brakes when riding down long slopes, as this will cause the internal brake parts to become very hot, and this may weaken braking performance. It may also cause a reduction in the amount of brake grease inside the brake, and this can lead to problems such as abnormally sudden braking. The design of the Shimano Inter-M brake system has been carried out based on standards such as ISO 4210 and DIN 79100-2. These standards specify the performance for an overall weight of 100 kg. If the overall weight exceeds 100 kg, the braking force provided by the system may be insufficient for correct braking, and durability of the system may also be reduced.
- If any of the following occur while using the brakes, stop riding immediately and ask the place of purchase to carry out inspection and repairs.
 - If abnormal noise is heard when the brakes are applied
 - If braking force is abnormally strong
 - If braking force is abnormally weak
 In the case of 1) and 2), the cause might be not enough brake grease, so ask the place of purchase to grease the mechanism with special roller brake grease.
- In order to get the best performance from the Shimano Inter-M brake, be sure to use Shimano brakes cables and brake levers as a set.

(The amount of movement of the inner cable must be 14.5 mm or more when the brake lever is depressed. If it is less than 14.5 mm, braking performance will suffer, and the brakes may fail to work.)
- Check that the brake arm is securely fastened to the chainstay by the brake arm clip. If it is not installed correctly, braking performance will suffer.
- If the brakes are used frequently, the brake drum may become hot. Do not touch the brake drum for at least 30 minutes after you finish riding the bicycle.

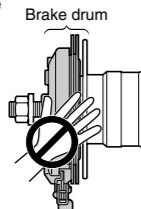

- If the brake cable becomes rusted, braking performance will suffer. If this happens, replace the brake cable with a genuine Shimano brake cable and re-check the braking performance.
- The BR-IM31-R brake unit should never be disassembled. If it is disassembled, it will no longer work properly.

NOTE:

- Use a wheel with 3x or 4x spoke lacing. Wheels with radial lacing cannot be used because the spokes and the wheel can be damaged when applying the brakes and brake noise can be generated.
- You can shift gears while pedaling, but on rare occasions the pawls and ratchet inside the hub may produce some noise afterwards as part of normal gear shifting operation.
- The Inter-M brake is different from conventional brakes in that the inside of the brake drum is filled with grease. This may cause the turning of the wheel to be slightly heavier than usual, particularly in cold weather.
- If the wheel becomes stiff and difficult to turn, you should lubricate it with grease.
- Do not apply any lubricant to the inside of the hub, otherwise the grease will come out.
- You should periodically wash the sprockets in a neutral detergent and then lubricate them again. In addition, cleaning the chain with neutral detergent and lubricating it can be an effective way of extending the useful life of the sprockets and the chain.
- If the chain keeps coming off the sprockets during use, replace the sprockets and the chain.
- Parts are not guaranteed against natural wear or deterioration resulting from normal use.
- For maximum performance we highly recommend Shimano lubricants and maintenance products.
- For any questions regarding methods of handling or adjustment, please contact the place of purchase.

SI-3R40E

SG-3R40
BR-IM31-R

Inter-3 Hub

Inter-M Brake

Technical Service Instructions

Be sure to read these service instructions in conjunction with the service instructions for the Inter-3 shifting lever before use.

Installation of the hub to the frame

- Mount the chain onto the sprocket, and then set the hub axle into the fork end.

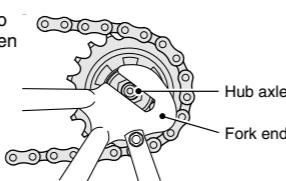

- Place the non-turn washer onto the outside of the left side of the hub axle. At this time, turn the hub axle so that the projection of the non-turn washer fits into the groove of the fork end.

- The projecting part should be on the fork end side.
- Install the non-turn washer so that the projecting part is securely in the fork end groove on either side of the hub axle.

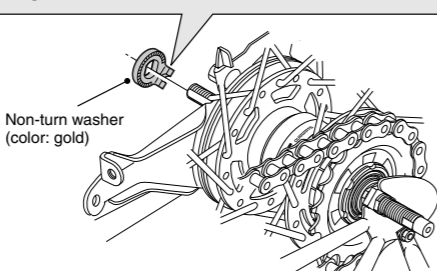

Note:

- When installing the kickstand to the hub, install the non-turn washer to the outside of the kickstand so that the projecting part fits into the groove of the kickstand.
- If installing other parts such as a mudguard stay, install them on the outside of the non-turn washer.

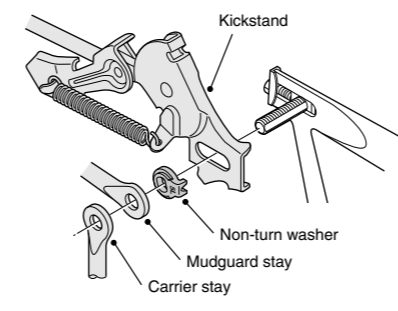

- Install the brake arm of the Inter-M brake to the chainstay with the brake arm clip, provisionally tighten the clip screw and clip nut, and then tighten the brake unit fixing nut.

Note:

If the brake arm is in the incorrect position as shown in the illustration so that it cannot be provisionally installed to the chainstay, loosen the brake unit fixing nut and turn the brake arm. Then, after provisionally securing the brake arm to the chainstay, tighten the brake unit fixing nut.

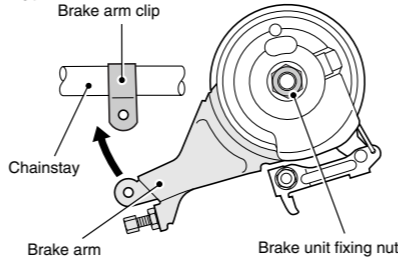

Tightening torque:
20 – 25 N·m {200 – 250 kgf·cm}

- Take up any looseness in the chain, and then secure the wheel to the frame using flange nuts or hub nuts.

For axle length of 170.3 mm

Secure both the left and right ends of the hub axle with 11 mm flange nuts.

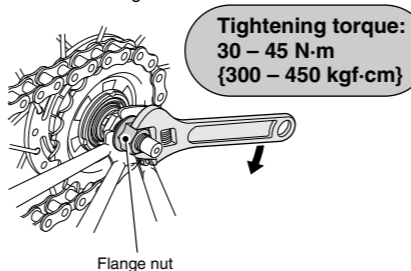

Tightening torque:
30 – 45 N·m
{300 – 450 kgf·cm}

Note:

Check that the distance from the edge of the flange nut to the right end of the hub axle is between 8 and 13 mm.

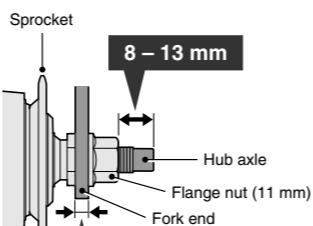

Total width of fork end and chain tensioner should be 4 to 7.5 mm.

For axle length of 189.4 mm

- If the total width of the fork end, kickstand and other parts such as the mudguard stay is 8.5 to 11.5 mm

Secure the right end of the hub axle with two 3.2 mm toothed washers and a 9 mm hub nut.

Secure the left end of the hub axle with one 3.2 mm toothed washer and a 9 mm hub nut.

Example: Set in the order shown in the diagram below.

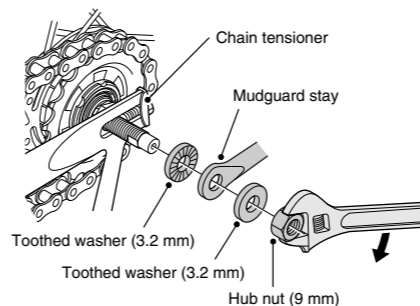

Tightening torque:
30 – 45 N·m
{300 – 450 kgf·cm}

- If the total width of the fork end, kickstand and other parts such as the mudguard stay is 11.5 to 14.5 mm

Secure both ends of the hub axle with one 3.2 mm toothed washer and a 9 mm hub nut.

Example: Set in the order shown in the diagram below.

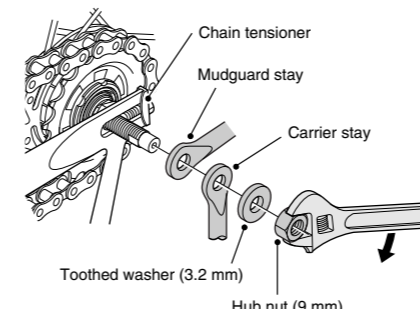

Tightening torque:
30 – 45 N·m
{300 – 450 kgf·cm}

- If the total width of the fork end, kickstand and other parts such as the mudguard stay is 14.5 to 17 mm

Secure both ends of the hub axle with one 2 mm toothed washer and a 7 mm hub nut.

Example: Set in the order shown in the diagram below.

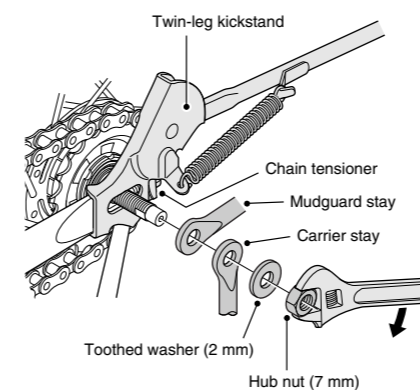

Tightening torque:
30 – 45 N·m
{300 – 450 kgf·cm}

Note:

For each of the situations in 1), 2) and 3), check that the distance from the edge of the hub nut to the right end of the hub axle is between 8 and 13 mm.

- Fix the brake arm of the Inter-M brake securely to the chainstay with the brake arm clip.

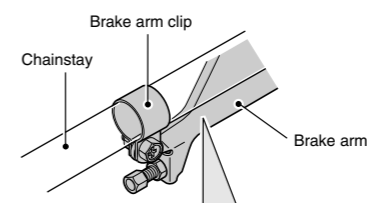

If excessive force is applied to the brake arm, the wheel will become difficult to turn. Make sure that you don't apply excessive force when installing.

Note:

- When installing the brake arm clip, securely tighten the clip screw while holding the clip nut with a 10 mm spanner.

Tightening torque:
2 – 3 N·m {20 – 30 kgf·cm}

- After installing the brake arm clip, check that the clip screw protrudes about 4 mm from the surface of the clip nut.

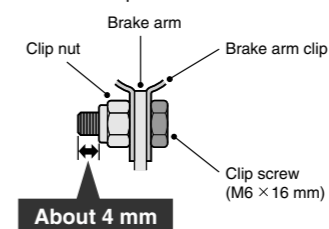

About 4 mm

Installing the brake cable

- Place the cable adjusting bolt so that it is 15 – 17 mm from the end of the brake arm, and then pass the inner cable through the cable adjusting bolt of the brake arm and then through the hole in the inner cable fixing bolt.

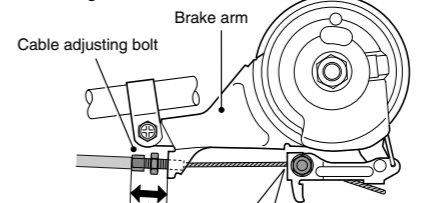

Should be 15 – 17 mm

- Check that both ends of the outer casing are securely inserted into the cable adjusting bolts of both the brake lever and brake arm.

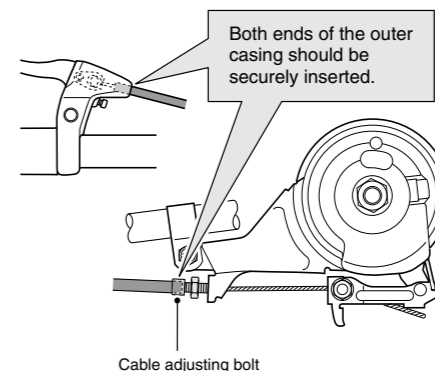

Both ends of the outer casing should be securely inserted.

- Pull the link back until it stops. Then, while pulling the inner cable to apply the full amount of tension to the cable, tighten the inner cable fixing nut.

Tightening torque:
6 – 8 N·m {60 – 80 kgf·cm}

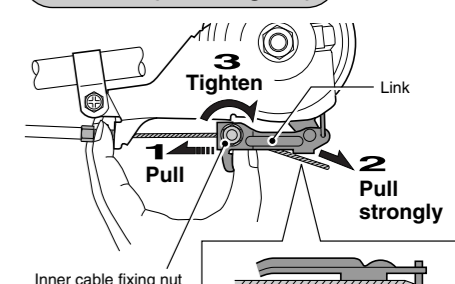

Note:
Set the inner cable so that it passes below the link.

Adjusting the brake cable

- After checking that the wheel does not easily turn while the brake cable is being pulled, depress the brake lever about 10 times as far as the grip in order to run in the brake cable.

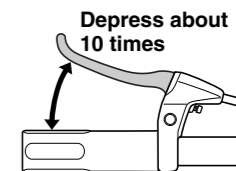

Depress about 10 times

Note:
If the brake cable is not run in, it will need to be adjusted again after only a short period of use.

- Turn the cable adjusting bolt so that there is about 15 mm of play in the brake lever.

(The amount of brake lever play is the distance from the position where the brake lever is not operated to the position where a force is felt suddenly when the brake lever is pulled.)

15 mm of play

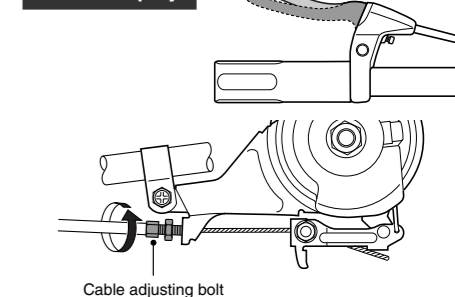

- After depressing the brake lever to check the braking performance, secure the cable adjusting bolt with the cable adjusting nut.

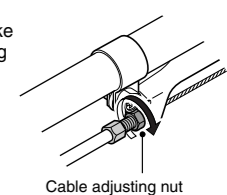

Tightening torque:
1 – 2 N·m {10 – 20 kgf·cm}

These service instructions explain how to use and maintain the Shimano bicycle parts which have been used on your new bicycle. For any questions regarding your bicycle or other matters which are not related to Shimano parts, please contact the place of purchase or the bicycle manufacturer.

These service instructions are printed on recycled paper. Please note: Specifications are subject to change for improvement without notice. (English)

SHIMANO

SHIMANO AMERICAN CORPORATION
One Holland, Irvine, California 92618, U.S.A. Phone: +1-949-951-5003

SHIMANO EUROPE B.V.
Industrieweg 24, 8071 CT Nunspeet, The Netherlands Phone: +31-341-272222

SHIMANO INC.
3-77 Oimatsu-cho, Sakai, Osaka 590-8577, Japan