

General Safety Information

WARNING – To avoid serious injuries:

- When installing the hub to the frame, be sure to install the correct non-turn washers to the left and right sides, and securely tighten the hub nuts to the specified torques. If the non-turn washers are installed to one side only, or if the hub nuts are not tightened sufficiently, the non-turn washer may fall out, which could cause the hub axle to rotate and the cassette joint to turn. This may then cause the handlebars to be accidentally pulled by the shifting cable, and an extremely serious accident could result.
- Obtain and read the service instructions carefully prior to installing the parts.** Loose, worn, or damaged parts may cause serious injury to the rider. We strongly recommend only using genuine Shimano replacement parts.
- The bolt on the hub shell is the bolt used when changing the oil. Never loosen this bolt except to change the oil. Doing so may cause oil to leak out, resulting in splashing.
- Before attaching the disc rotor, be sure to install the rotor spacer. Failure to do may cause the disc rotor to loosen, resulting in abnormal noise or brake malfunction.
- Check that the wheels are fastened securely before riding the bicycle. If the wheels are loose in any way, they may come off the bicycle and serious injury may result.
- Read these Technical Service Instructions carefully, and keep them in a safe place for later reference.

NOTE:

- When assembling a wheel, use the 3x or 4x spoke lacing, but not the radial lacing. Improper assembly may cause the spokes or wheel to be damaged or abnormal noise to be generated when applying the brake.
- You can shift gears while pedaling, but on rare occasions the pawls and ratchet inside the hub may produce some noise afterwards as part of normal gear shifting operation.
- The 11-speed hub has a built-in mechanism to support shifting. When this support mechanism operates during shifting, noise or vibration may occur. The shifting feel may also change depending on the gear position at the time of shifting. Noise may also be generated if the crank arms are turned backward or if the bicycle is pushed backward when the gear position is 7 – 11. These occurrences are a normal result of the structure of the internal gear shifting mechanism, and are not a sign of a malfunction.
- The CJ-S700 cassette joint should only be used with sprockets from 18T to 23T.
- If using the CT-S500 chain tensioner, use the special CS-S500 18T or 20T sprocket with chain guard. Do not use any other type of sprocket; otherwise, the chain may come off the sprocket.
- It is recommended that the gear ratio of the front chain ring be set to approx. 1.9. Example: F34T – R18T, F39T – R20T, F45T – R23T
- To maintain the performance of the unit, it is recommended that maintenance such as internal oil change be performed at the shop from which you purchased it or at a professional shop after riding a total of 1,000km after start of use and every 2 years after that (every 5,000km if riding frequently). In addition, the SG-S700 Oil and TL-S703 maintenance kit must be used for maintenance. For oil maintenance, please refer to service instruction of TL-S703. To install right hand side seal, use TL-S704. Failure to use the SG-S700 Oil may cause problems such as oil leakage, internal mechanism malfunctions, etc.
- You should periodically wash the sprockets in a neutral detergent and then lubricate them again. In addition, cleaning the chain with neutral detergent and lubricating it can be an effective way of extending the useful life of the sprockets and the chain.
- If the chain keeps coming off the sprockets during use, replace the sprockets and the chain.
- Parts are not guaranteed against natural wear or deterioration resulting from normal use.
- For maximum performance we highly recommend Shimano lubricants and maintenance products.
- For any questions regarding methods of handling or adjustment, please contact the place of purchase.
- Do not disassemble the hub by yourself. If it is necessary to disassemble it, consult the shop from which you purchased it.

Installation of the CS-S500 sprocket with chain guard

1. Install the chain guard to the right hand dust cap of the hub body, and then install right hand dust cap D to the driver.

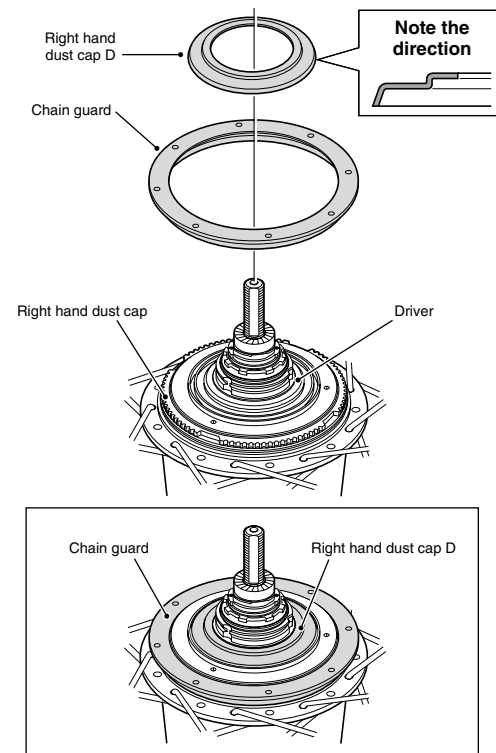

2. Install the CS-S500 sprocket to the driver on the right side of the hub body with the guard plate facing outward, and secure it in place with the snap ring.

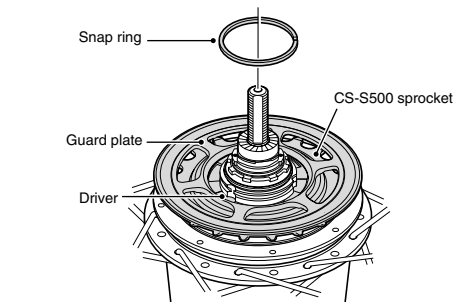

Installation of the cassette joint to the hub

1. Install the driver cap to the driver on the right side of the hub body.

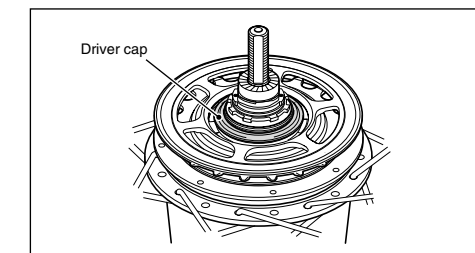
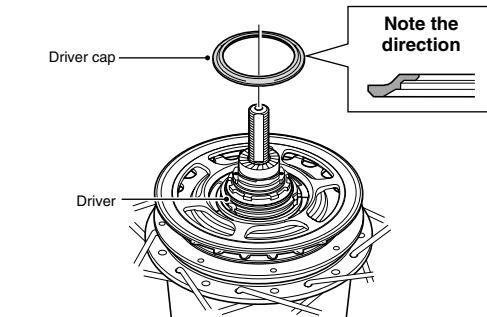

2. Turn the cassette joint pulley in the direction of the arrow in the illustration to align the red ● marks on the pulley and the bracket. With the cassette joint in this condition, install it so that the red ● mark on the cassette joint is aligned with the red ● mark on the right side of the hub body.

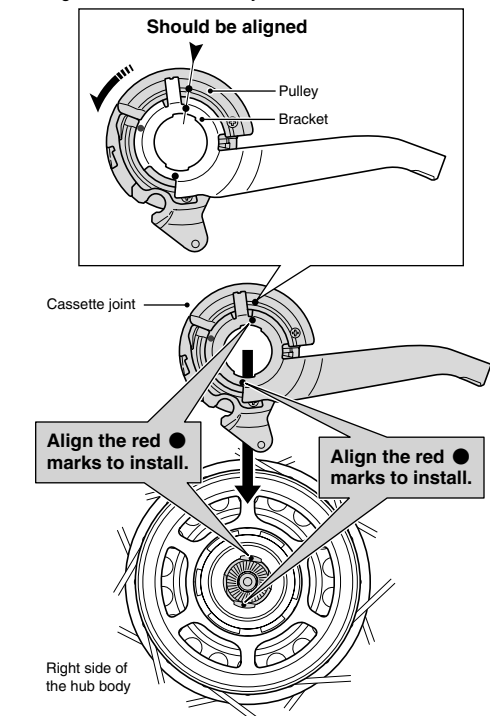

3. Secure the cassette joint to the hub with the cassette joint fixing ring. When installing the cassette joint fixing ring, align the yellow ● mark with the yellow ● mark on the cassette joint pulley, and then turn the cassette joint fixing ring 45° clockwise.

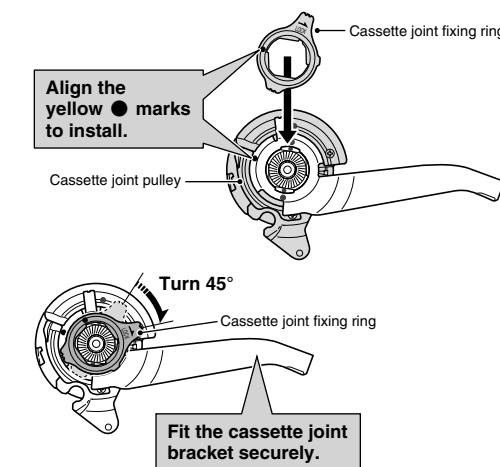

Installation of the rotor

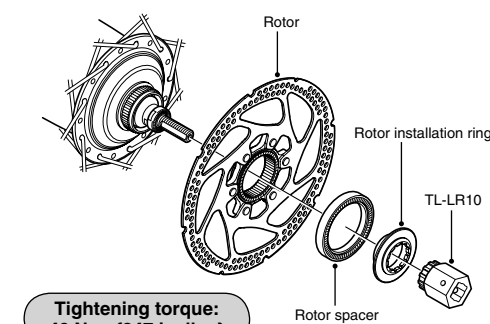

Tightening torque:
40 N·m {347 in. lbs.}

Installation of the hub to the frame

The method of installing the hub to the frame is the same when the chain tensioner is being used and when it is not being used.

1. Mount the chain on the sprocket, and then set the hub axle into the dropouts.

When not using the chain tensioner

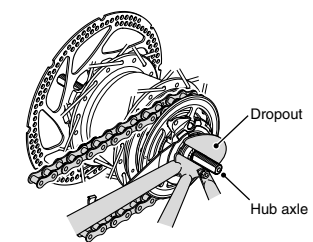

When using the chain tensioner

When using the chain tensioner, be sure to read these service instructions together with the service instructions for the chain tensioners (CT-S500/CT-S510).

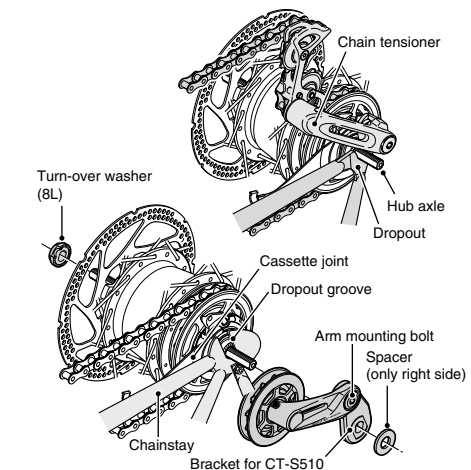

2. Place the non-turn washers on the right side and left side of the hub axle. At this time, turn the cassette joint so that the projecting parts of the dropouts and the cassette joint fit into the grooves of the dropouts and the cassette joint follows the inside of the chainstay.

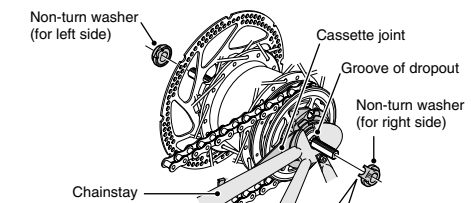

- Use whichever non-turn washers match the shape of the dropouts. Different non-turn washers are used at the left and right sides.

Dropouts	Non-turn washer			
	Mark/Color	Right	Left	Size
Standard	5R/Yellow	5L/Brown		$\theta \leq 20^\circ$
	7R/Black	7L/Gray		$\theta \leq 38^\circ$
Reversed	6R/Silver	6L/White		$\theta = 0^\circ$
Reversed (full chain case)	5R/Yellow	5L/Brown		$\theta = 0^\circ$
Vertical	8R/Blue	8L/Green		$\theta = 60^\circ - 90^\circ$



- The projecting parts should be on the dropouts side.
- Install the non-turn washers so that the projecting parts is securely in the dropouts grooves on either side of the hub axle.

3. Take up the slack in the chain and secure the wheel to the frame with the cap nuts.

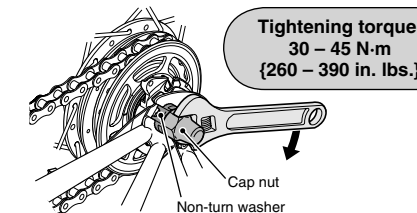

Adjusting the cassette joint

1. Set the shifting lever from [11] to [6]. Check to be sure that the yellow setting lines on the cassette joint bracket and pulley are aligned at this time.

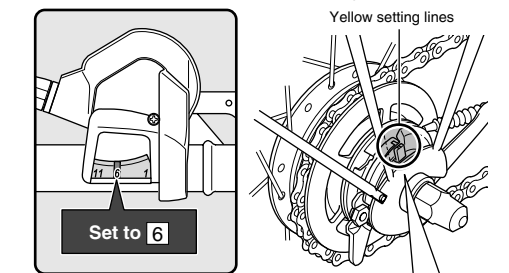

The yellow setting lines on the cassette joint are located in two places. Use the one that is easiest to see.

When bicycle is standing up

Should be straight

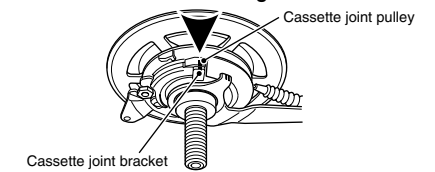

When bicycle is upside down

Should be straight

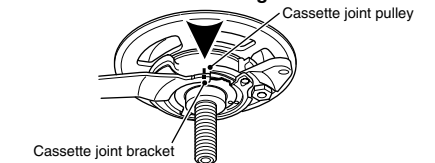

If the yellow setting lines are not aligned, turn the cable adjustment bolt of the shifting lever to align the setting lines. After this, move the shifting lever once more from [6] to [11] and then back to [6], and then re-check to be sure that the yellow setting lines are aligned.

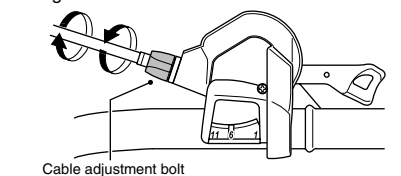

2. After adjusting the cassette joint, cut off the excess length of inner cable and then install the inner end cap. After attaching the inner end cap, bend the inner cable outward (toward the frame end) to prevent it from coming in contact with the chain.

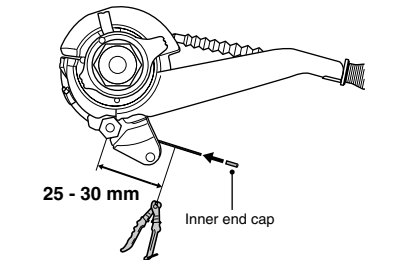

These service instructions explain how to use and maintain the Shimano bicycle parts which have been used on your new bicycle. For any questions regarding your bicycle or other matters which are not related to Shimano parts please contact the place of purchase or the bicycle manufacturer.

* Service Instructions in further languages are available at: <http://techdocs.shimano.com>

Please note: Specifications are subject to change for improvement without notice. (English)

SHIMANO

SHIMANO AMERICAN CORPORATION
One Holland, Irvine, California 92618, U.S.A. Phone: +1-949-951-5003

SHIMANO EUROPE B.V.
Industrieweg 24, 8071 CT Nunspeet, The Netherlands Phone: +31-341-272222

SHIMANO INC.
3-77 Oimatsu-cho, Sakai-ku, Sakai-shi, Osaka 590-8577, Japan

SI-37R0A-002

SG-S700
CS-S500
CJ-S700

Hub for Inter-11 Disc Brake
Sprocket with Chain Guard
Cassette joint

Technical Service Instructions

Be sure to read these service instructions in conjunction with the service instructions for the brake and the shifting lever before use.