

# Front Chainwheel FC-R453

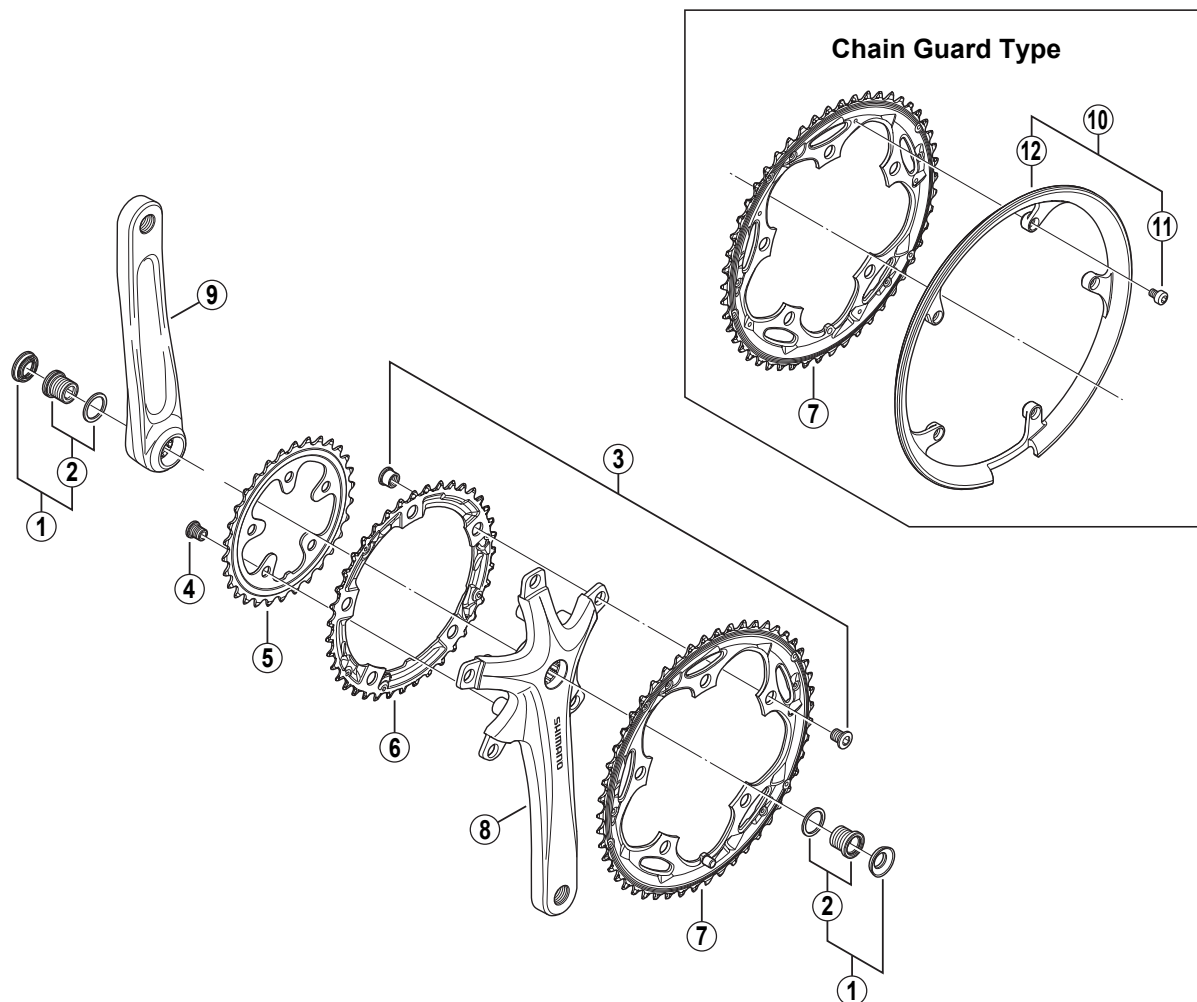

• Bolt circle diameter: 130 mm... (For outer gear and middle gear), 74 mm... (For inner gear)

FC-R450

ITEM NO.	SHIMANO CODE NO.	DESCRIPTION	INTERCHANGEABILITY
1	Y-1JH 98010	Crank Arm Fixing Bolt Unit	A
2	Y-1E4 98020	Crank Arm Fixing Bolt & Washer	A
3	Y-1HD 98020	Double Gear Fixing Bolt (M8 x 8.5) & Nut (5 sets)	A
4	Y-1H7 98010	Inner Gear Fixing Bolt (M8 x 8.5 / 5 pcs.)	
* 5	Y-1JJ 30000	Chainring 30T (Silver)	
6	Y-1H9 98010	Chainring 39T (Silver)	
7	Y-1H9 98020	Chainring 50T-D (Silver)	
	Y-1H9 98030	Chainring 50T-D (Silver) for Chain Guard	
8	Y-1JJ 05000	Right Hand Crank Arm 170 mm	
	Y-1JJ 03000	Right Hand Crank Arm 175 mm	
9	Y-1JH 05100	Left Hand Crank Arm 170 mm	A
	Y-1JH 03100	Left Hand Crank Arm 175 mm	A
10	Y-1H9 98040	Chain Guard & Fixing Bolts	A
11	Y-1BA 98040	Chain Guard Fixing Bolt (5 pcs.)	A
12	Y-1H9 12000	Chain Guard	A

A: Same parts.

B: Parts are usable, but differ in materials, appearance, finish, size, etc.

Absence of mark indicates non-interchangeability.

Aug.-2009-2742A  
© Shimano Inc. P

Specifications are subject to change without notice.

# SHIMANO