

## **Dealer's Manual**

# **MTB Wheel Set Non-Series**

WH-MT68  
WH-MT66  
WH-MT35  
WH-MT15  
WH-MT500  
WH-MT501  
WH-MT600  
WH-MT620

# CONTENTS

<b>IMPORTANT NOTICE.....</b>	<b>3</b>
<b>TO ENSURE SAFETY.....</b>	<b>4</b>
<b>INSTALLATION .....</b>	<b>7</b>
Tire size.....	7
List of tools to be used .....	8
Installing the spoke protector.....	8
Installing/removing the cassette sprocket.....	9
Installing the disc brake rotor.....	9
<b>MAINTENANCE.....</b>	<b>10</b>
Spoke tension value.....	10
Replacing the spoke.....	11
Disassembly and Assembly < Thru axle type >.....	12
Disassembly and Assembly < Quick release type > .....	19
Replacement of the freewheel body < Quick release type >.....	21
Replacement of the freewheel body < Thru axle type >.....	22
Replacing the covering tape and rim hole caps .....	24
Replacing tubeless tape.....	26
How to use a sealant (In the case of type-A) .....	28
Installing and removing tubeless tires.....	29

## IMPORTANT NOTICE

- **This dealer's manual is intended primarily for use by professional bicycle mechanics.**

Users who are not professionally trained for bicycle assembly should not attempt to install the components themselves using the dealer's manuals.

If any part of the information on the manual is unclear to you, do not proceed with the installation. Instead, contact your place of purchase or a local bicycle dealer for their assistance.

- Make sure to read all owner's manuals included with the product.
- Do not disassemble or modify the product other than as stated in the information contained in this dealer's manual.
- All manuals and technical documents are accessible online at <https://si.shimano.com>.
- For consumers who do not have easy access to the internet, please contact a SHIMANO distributor or any of the SHIMANO offices to obtain a hardcopy of the User's Manual.
- Please observe the appropriate rules and regulations of the country, state or region in which you conduct your business as a dealer.

**For safety, be sure to read this dealer's manual thoroughly before use, and follow it for correct use.**

The following instructions must be observed at all times in order to prevent personal injury and physical damage to equipment and surroundings.

The instructions are classified according to the degree of danger or damage which may occur if the product is used incorrectly.



**DANGER**

Failure to follow the instructions will result in death or serious injury.



**WARNING**

Failure to follow the instructions could result in death or serious injury.



**CAUTION**

Failure to follow the instructions could cause personal injury or physical damage to equipment and surroundings.

# TO ENSURE SAFETY

## WARNING

- **Be sure to follow the instructions provided in the manuals when installing the product.**  
Only use SHIMANO genuine parts. If a component or replacement part is incorrectly assembled or adjusted, it can lead to component failure and cause the rider to lose control and crash.
-  Wear approved eye protection while performing maintenance tasks such as replacing components.

### Be sure to also inform users of the following:

- **Check that the wheels are fastened securely before riding the bicycle.**  
**If the wheels are loose in any way, they may come off the bicycle and cause serious injury.**
- Before riding the bicycle, carefully check the hubs to make sure that there are no cracks in the axles; if there is any sign of a crack or any other unusual condition, DO NOT use the bicycle.  
This wheel is not designed for downhill bicycle riding and freeriding. Hence, do not use it for downhill riding, otherwise the wheel may become bent or otherwise damaged, and accidents may occur as a result.
- Be sure to read the manual for the product thoroughly, before using the product.  
If the quick release mechanism is not used correctly, the wheel may come off the bicycle and serious injury could result.
- Before use, check the wheels to make sure that there are no bent or loose spokes, dents, scratches or cracks on the rim surface. Do not use the wheel if any of these problems are found.  
The wheel may break, and you may fall.

### < F15 (Front 15 mm Axle), R12 (Rear 12 mm Axle) Wheel (Thru Axle) >

- This wheel is only to be used in combination with the special front fork/frame and the fixed axle.  
If it is used in combination with any other front fork/frame or fixed axle, it may cause the wheel to become detached from the bicycle while you are riding and result in serious bodily injury.
- Make sure that even if the axle release lever is tightened as much as possible by hand, the axle release lever does not interfere with the disc brake rotor.  
If the axle release lever is on the same side as the disc brake rotor, there is the danger that it may interfere with the disc brake rotor. If the lever interferes with the disc brake rotor, stop using the wheel and consult a dealer or an agency.
- Be sure to read the manual for the product thoroughly, before using the product. If the axle release lever is not used correctly, the wheel may come off the bicycle and serious injury could result.

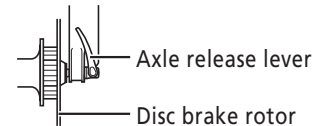

### TL: Tubeless wheel

- The tires should be installed and removed by hand.  
If this is difficult, a plastic tire lever for tubeless wheels may be used. In such cases, be sure to check that the rim surface has not been dented, scratched, or cracked as there is a risk of causing damage to the air seal between the tire and the rim, which would result in air leakage. For carbon rims, check that there is no carbon peeling or cracking etc. Finally, make sure there is no air leakage.

### < F15 Wheel (Thru Axle) >

- When installing the front wheel to the front suspension fork, always be sure to follow the directions given in the owner's manual for the front suspension fork.  
The securing method and tightening torque for the front wheel both vary depending on the type of front suspension fork being used. If the directions are not followed correctly, the front wheel may fall out of the front suspension fork and serious injury may result.

#### < F (Front), R (Rear) Wheel >

- Make sure that even if the quick release lever is tightened as much as possible by hand, the quick release lever does not interfere with the disc brake rotor.  
If the quick release lever is on the same side as the disc brake rotor, there is the danger that it may interfere with the disc brake rotor. If the lever interferes with the disc brake rotor, stop using the wheel and consult a dealer or an agency.

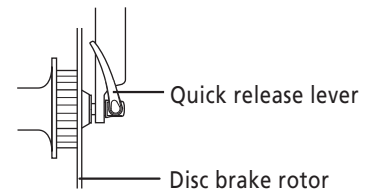

#### For Installation to the Bicycle, and Maintenance:

- Use a disc brake.  
These wheels are designed exclusively for use with disc brakes. Do not use these wheels with rim brakes.



#### Be sure to also inform users of the following:

- The tires should be inflated to the pressure indicated on the tires before use.
- If you will be using a puncture repair agent or sealant, consult the place of purchase or a distributor.

#### < WH-MT66/WH-MT68/WH-MT600/WH-MT620 >

- When using these wheels, be sure to use covering tape and rim hole caps for type A or the tubeless tape for type B.
- Use SHIMANO genuine parts for the covering tape, rim hole caps, and tubeless tape.  
It is recommended to use SHIMANO genuine parts to prevent punctures and other possible damage.
- Do not use rim tape.  
Rim tape may make it difficult to remove and install the tire, and the tire or tube may become damaged or the tires may suddenly puncture and come off, and severe injury may result.

#### < WH-MT35/WH-MT15-A/WH-MT500/WH-MT501 >

- Use rim tape which can withstand high pressure, otherwise the tires may suddenly puncture, and you may fall off the bicycle.  
Furthermore, it is not recommended that you reuse rim tape after it has been removed from the wheel. If the tape is reused, a sudden puncture may occur, and you may fall off the bicycle.

#### ■ Burn-in period

- Take note of the braking force during the burn-in period.  
Disc brakes have a burn-in period, and the braking force will gradually increase as the burn-in period progresses. Make sure that you are aware of any such increases in braking force when using the brakes during the burn-in period. The same thing will happen when the brake pads or the disc brake rotor are replaced.

#### For Installation to the Bicycle, and Maintenance:

- When using the SHIMANO original tool (TL-FC36) to remove and install the disc brake rotor fixing ring, be careful not to touch the outside of the disc brake rotor with your hands.  
Wear gloves to protect your hands from getting cut.

## NOTICE

### Be sure to also inform users of the following:

- Special nipple wrenches are available as optional accessories.
- Do not apply any oil to the inside of the hub, otherwise the grease will come out.
- It is recommended that you ask a bicycle dealer to adjust the spoke tensions if there is any deviation in the spokes and after the first 1,000 km of riding.
- Do not use detergent or other chemicals when wiping the wheel, otherwise it may cause the sticker on the rim to peel off.
- Products are not guaranteed against natural wear and deterioration from normal use and aging.
- For maximum performance we highly recommend SHIMANO lubricants and maintenance products.

### For Installation to the Bicycle, and Maintenance:

- Use of genuine SHIMANO spokes and nipples is strongly recommended. If non-SHIMANO parts are used, the area where the spokes fit into the hub unit may become damaged.
- If the wheel becomes stiff and difficult to turn, you should lubricate it with grease.
- For compatible reflectors and spoke protectors, check the specifications table (<https://si.shimano.com>).

The actual product may differ from illustrations, as this manual is intended mainly to explain the procedures for using the product.

# INSTALLATION

## ■ Tire size

Series	Size	Quick release type	Thru Axle type	Tire size
Non-Series	26	WH-MT68-R	WH-MT68-F15 WH-MT68-R12	26x1.95-2.50
	26	WH-MT66-F WH-MT66-R	WH-MT66-F15	26x1.50-2.25
	29	WH-MT66-F-29 WH-MT66-R-29	WH-MT66-F15-29 WH-MT66-R12-29	29x1.50-2.25
	26	WH-MT35-F WH-MT35-R	WH-MT35-F15	26x1.50-2.25
	27.5	WH-MT35-F-275 WH-MT35-R-275	WH-MT35-F15-275	27.5x1.50-2.25
			WH-MT500-F15-275 WH-MT500-R12-275 WH-MT500-F15-B-275 WH-MT500-R12-B-275 WH-MT501-R12-B-275 WH-MT600-TL-F15-275 WH-MT600-TL-R12-275 WH-MT600-TL-F15-B-275 WH-MT600-TL-R12-B-275	27.5x2.00-2.40
		-	WH-MT620-TL-F15-B-275 WH-MT620-TL-R12-B-275	27.5x2.25-2.50
	29	WH-MT35-F-29 WH-MT35-R-29	WH-MT35-F15-29	29x1.50-2.25
			WH-MT500-F15-29 WH-MT500-R12-29 WH-MT500-F15-B-29 WH-MT500-R12-B-29 WH-MT501-R12-B-29 WH-MT600-TL-F15-29 WH-MT600-TL-R12-29 WH-MT600-TL-F15-B-29 WH-MT600-TL-R12-B-29	29x2.00-2.40
		-	WH-MT620-TL-F15-B-29 WH-MT620-TL-R12-B-29	29x2.25-2.50
	26	WH-MT15-A-F WH-MT15-A-R	WH-MT15-A-F15	26x1.50-2.25
	27.5	WH-MT15-A-F-275 WH-MT15-A-R-275	WH-MT15-A-F15-275	27.5x1.50-2.25
	29	WH-MT15-A-F-29 WH-MT15-A-R-29	WH-MT15-A-F15-29	29x1.50-2.25

## ■ List of tools to be used

The following tools are needed to assemble this product.

Usage location	Tool
Hub	13 mm hub spanner, 15 mm hub spanner, 17 mm hub spanner, 18 mm hub spanner, 22 mm hub spanner, 23 mm hub spanner, TL-HS22, TL-FH15, TL-WR37

## ■ Installing the spoke protector

For information on wheels that can be installed, check the compatibility information (<https://productinfo.shimano.com>).

< CP-WH31 >

1. Install the pins to the spoke protector.

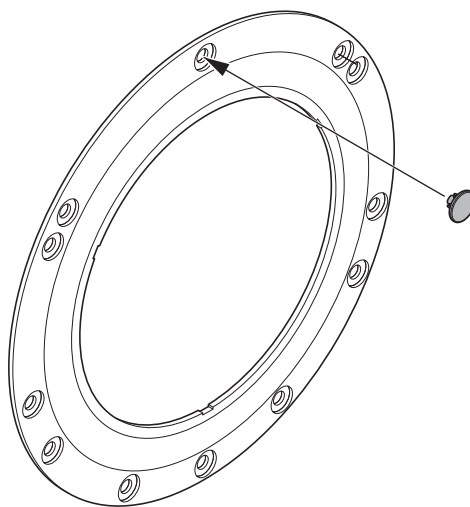

### NOTICE:

- For the pin installation position, refer to the following. There is a datum hole between the SHIMANO logo and the model name.

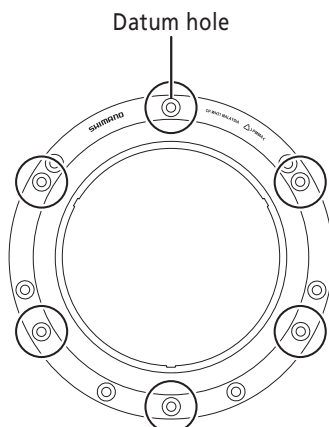



2. Install the spoke protector.  
Push the pins onto the outer spokes to install.

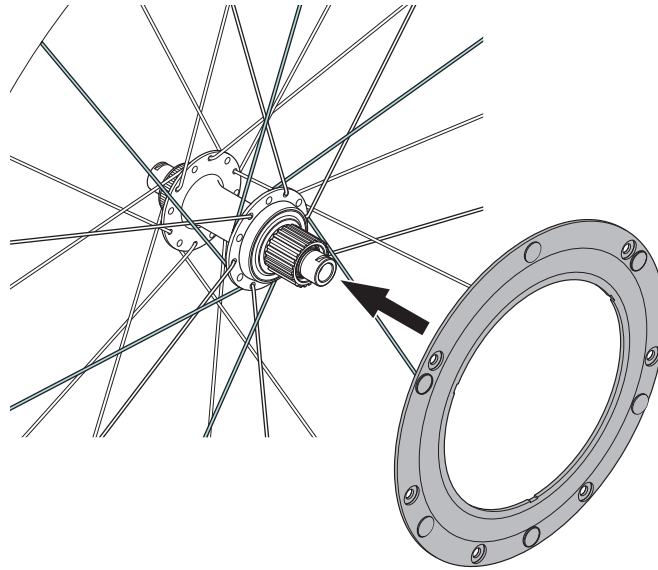

### ■ Installing/removing the cassette sprocket

Refer to the dealer's manual for the cassette sprocket to install/remove the cassette sprocket.

### ■ Installing the disc brake rotor

Refer to the dealer's manual for the disc brakes to install the disc brake rotor.

# MAINTENANCE

## ■ Spoke tension value

< WH-MT68/WH-MT66/WH-MT35/WH-MT15/WH-MT501/WH-MT600 >

Spoke tension value		
For front	Right side	Left side
	600 - 1,000 N	900 - 1,350 N
For rear	Right (sprocket) side	Left side
	900 - 1,350 N	600 - 1,000 N

\* These values should be used as a guide only.

< WH-MT500/WH-MT620 >

Spoke tension value		
WH-MT500-F/ WH-MT500-F15	Right side	Left side
	29": 550 - 850 N 27.5": 550 - 919 N	29": 800 - 1,200 N 27.5": 853 - 1,253 N
WH-MT500-F15-B		29" & 27.5": 800 - 1,200 N
WH-MT620-TL-F15-B	29" & 27.5": 880 - 1,158 N	29" & 27.5": 922 - 1,172 N
WH-MT500-R/ WH-MT500-R12	Right (sprocket) side	Left side
	29" & 27.5": 900 - 1,300 N	29": 550 - 850 N 27.5": 550 - 900 N
WH-MT500-R12-B		29" & 27.5": 550 - 900 N
WH-MT620-TL-R12-B	29" & 27.5": 1,003 - 1,253 N	29" & 27.5": 900 - 1,202 N

\* These values should be used as a guide only.

### MT68/MT66/MT500/MT600/MT620

Number of spokes: 24

\* Only the 29-inch type of MT66 has 28 spokes for the rear.

### MT35/MT15-A/MT501

Number of spokes: 28

\* MT35 has 24 spokes for the front, and MT501 has 24 spokes for the rear.

## ■ Replacing the spoke

1. Hook the spokes through the hub as shown in the illustration to install them.

< MT68/MT66/MT600 >

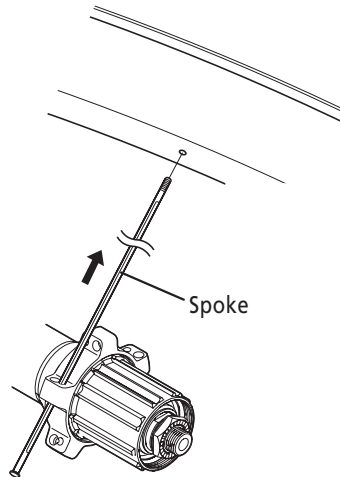

< MT35/MT15-A/MT500/MT501/MT620 >

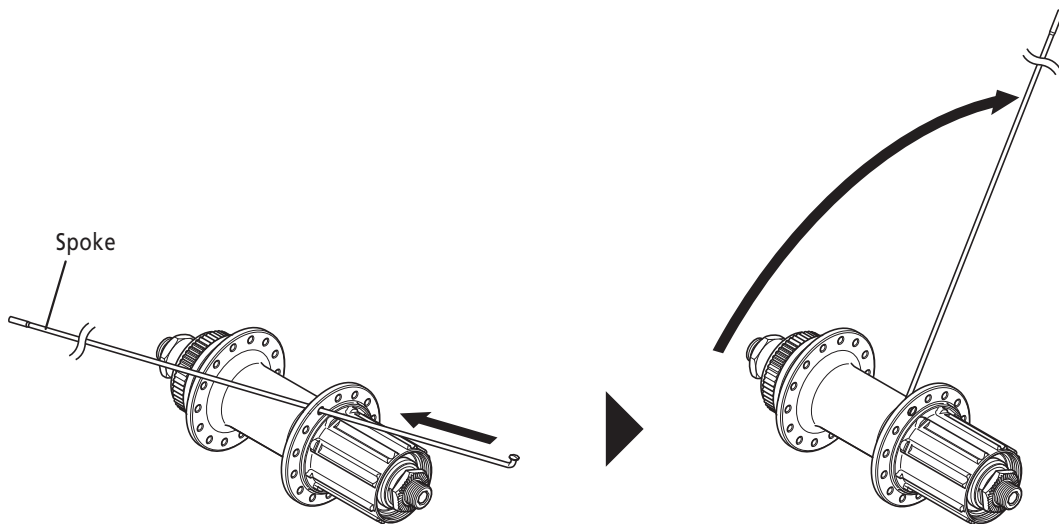

2.

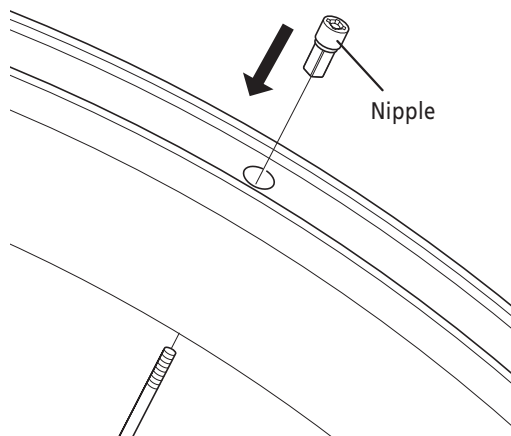

## ■ Disassembly and Assembly < Thru axle type >

MT68/MT66 < Front >

### < Disassembly >

These units can be disassembled as shown in the illustrations. Grease should be applied to each part at periodic intervals.

#### NOTICE:

- It cannot be disassembled from the left side of the hub (the side with the disc brake rotor fixing spline).
- Do not disassemble the dust cover which is crimped onto the axle pipe.

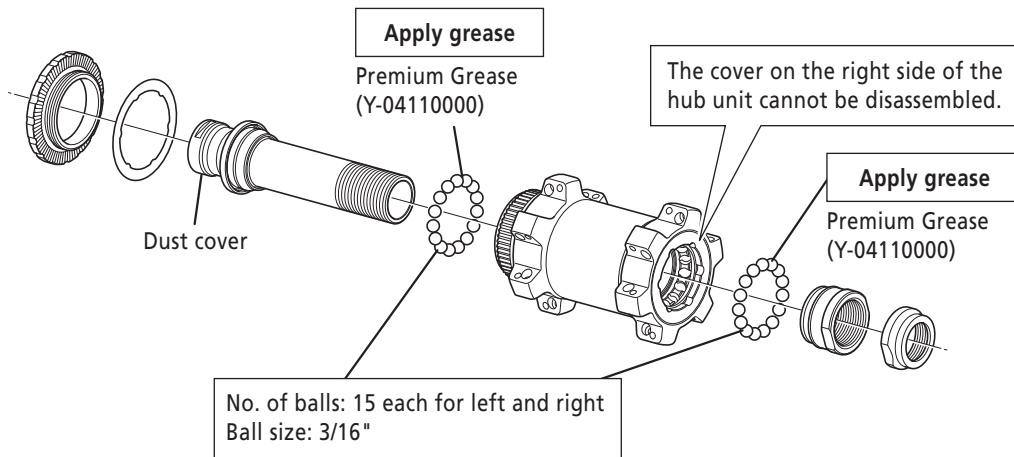

### < Assembly >

Install the axle pipe, and then use the SHIMANO original tools to tighten the lock nut so as to double-lock the mechanism as shown in the illustration.

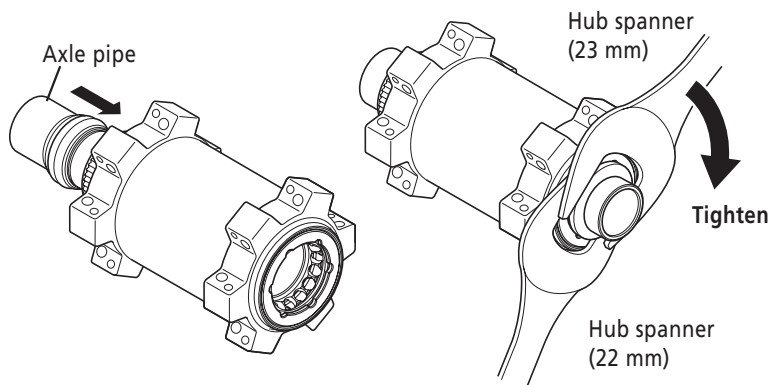

**Tightening torque:  
21 - 26 N·m**

< Disassembly >

These units can be disassembled as shown in the illustrations. Grease should be applied to each part at periodic intervals.

**NOTICE:**

- It cannot be disassembled from the left side of the hub (the side with the disc brake rotor fixing spline).
- Do not disassemble the dust cover which is crimped onto the LH axle cap.

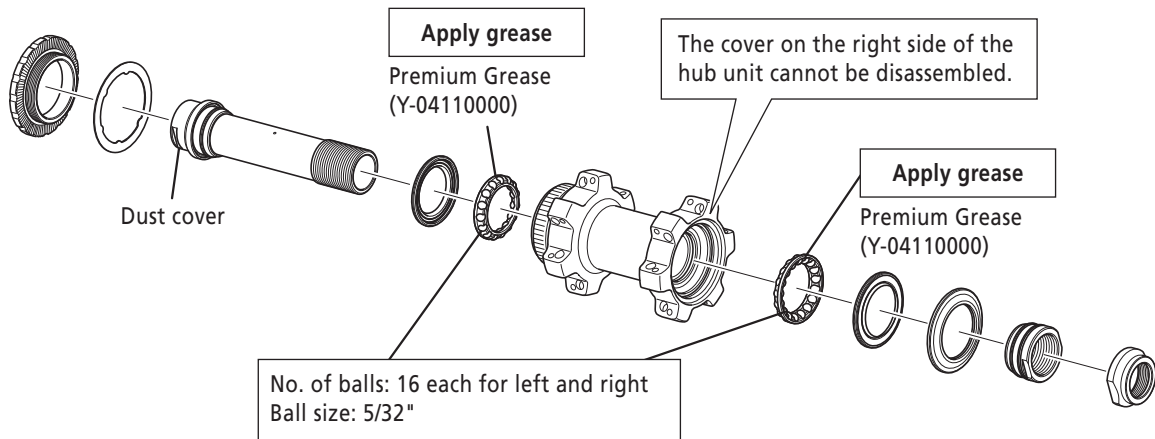

< Assembly >

Install the axle pipe, and then use the SHIMANO original tools to tighten the lock nut so as to double-lock the mechanism as shown in the illustration.

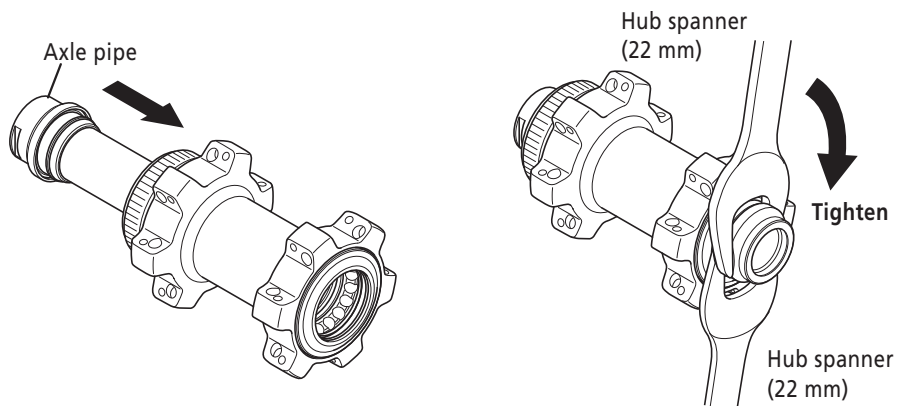

**Tightening torque:  
21 - 26 N·m**

### < Disassembly >

The unit can be disassembled as shown in the illustration. Apply grease to the various parts at periodic intervals.

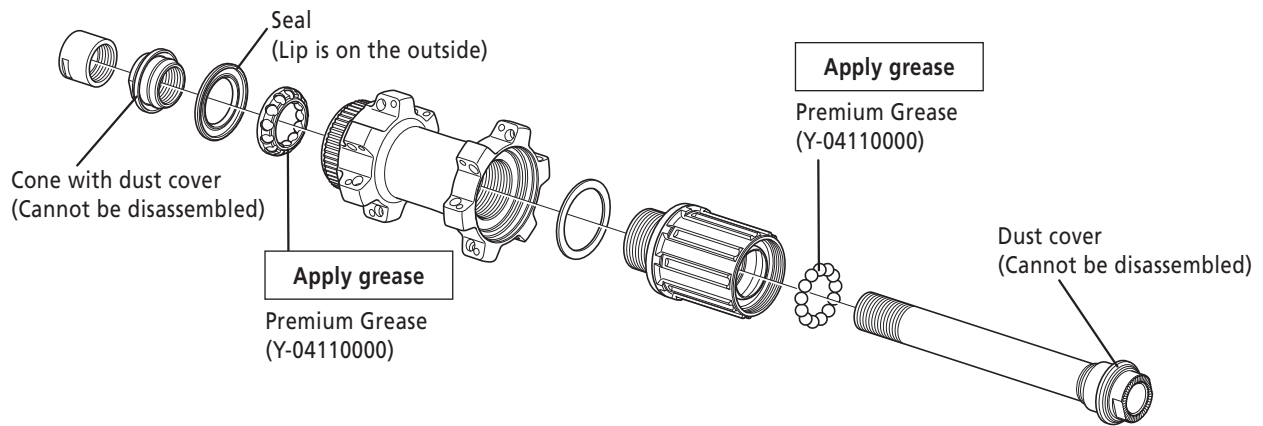

### NOTICE:

- When removing and installing the seal, do it very carefully so that the seal does not become bent. When reinstalling the seal, make sure that it is facing the right way, and insert it as far as it will go.
- Do not disassemble the waterproof cover crimped on the cone, and the hub axle.
- Do not attempt to disassemble the freewheel body, because it may result in a malfunction.

< Disassembly >

These units can be disassembled as shown in the illustrations. Grease should be applied to each part at periodic intervals.

**NOTICE:**

- It cannot be disassembled from the left side of the hub (the side with the disc brake rotor fixing spline).
- Do not disassemble the dust cover which is crimped onto the axle pipe.

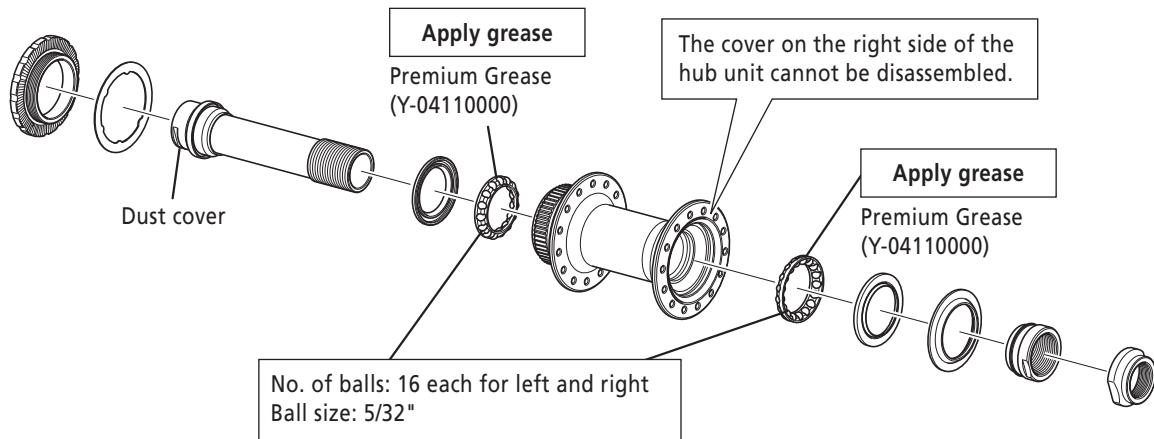

< Assembly >

Install the axle pipe, and then use the SHIMANO original tools to tighten the lock nut so as to double-lock the mechanism as shown in the illustration.

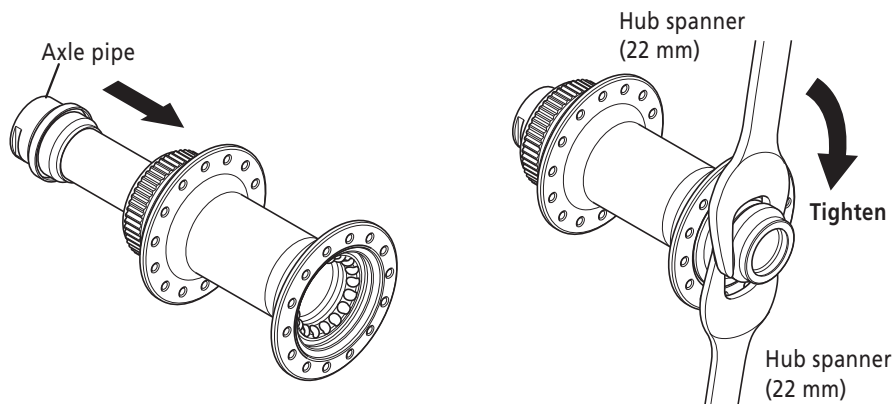

**Tightening torque:**  
21 - 26 N·m

< Disassembly >

The unit can be disassembled as shown in the illustration. Apply grease to the various parts at periodic intervals.

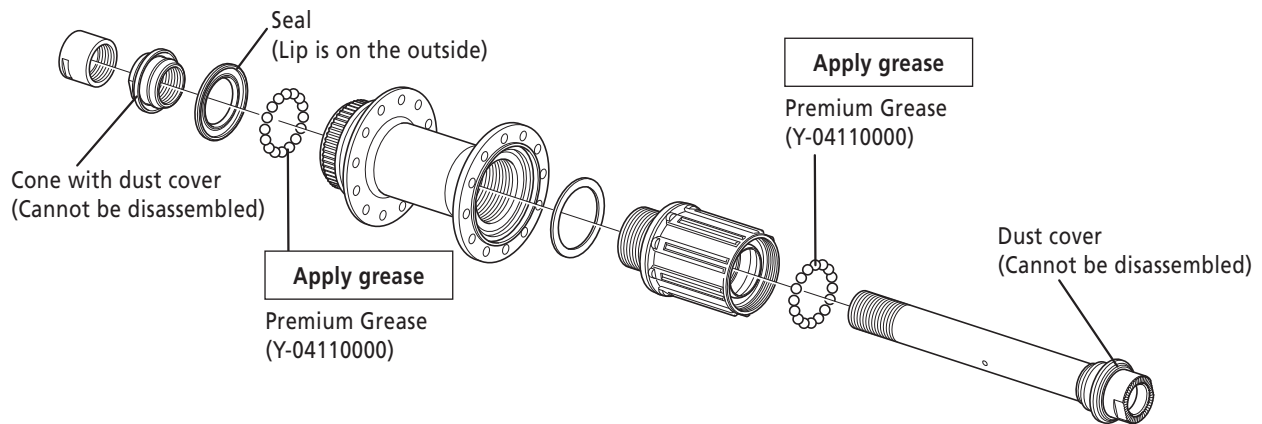

**NOTICE:**

- When removing and installing the seal, do it very carefully so that the seal does not become bent. When reinstalling the seal, make sure that it is facing the right way, and insert it as far as it will go.
- Do not disassemble the waterproof cover crimped on the cone, and the hub axle.
- Do not attempt to disassemble the freewheel body, because it may result in a malfunction.

< Disassembly >

The unit can be disassembled as shown in the illustration. Apply grease to the various parts at periodic intervals.

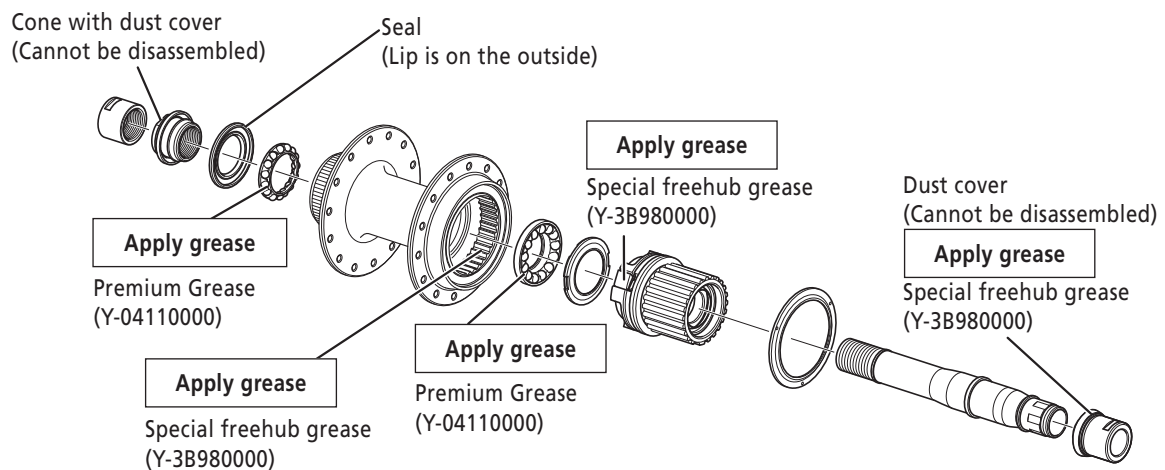

**NOTICE:**

- When removing and installing the seal, do it very carefully so that the seal does not become bent. When reinstalling the seal, make sure that it is facing the right way, and insert it as far as it will go.
- Do not disassemble the waterproof cover crimped on the cone, and the hub axle.
- Perform the assembly according to the assembly procedures when the freewheel body has been removed.
- Do not attempt to disassemble the freewheel body, because it may result in a malfunction.



- Special grease is used for the freewheel body. Do not mix it with other types of grease, as this may cause problems with the operation of the freewheel clutch mechanism.
- Apply special freehub grease to the areas indicated in the figure.

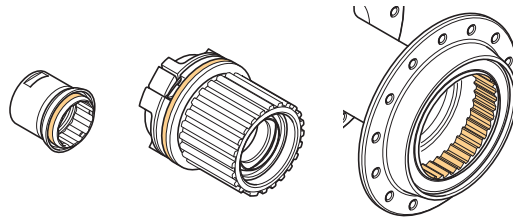

### < Assembly >

1. Install the hub axle, and then use the SHIMANO original tools to tighten the lock nut so as to double lock the mechanism as shown in the illustration.

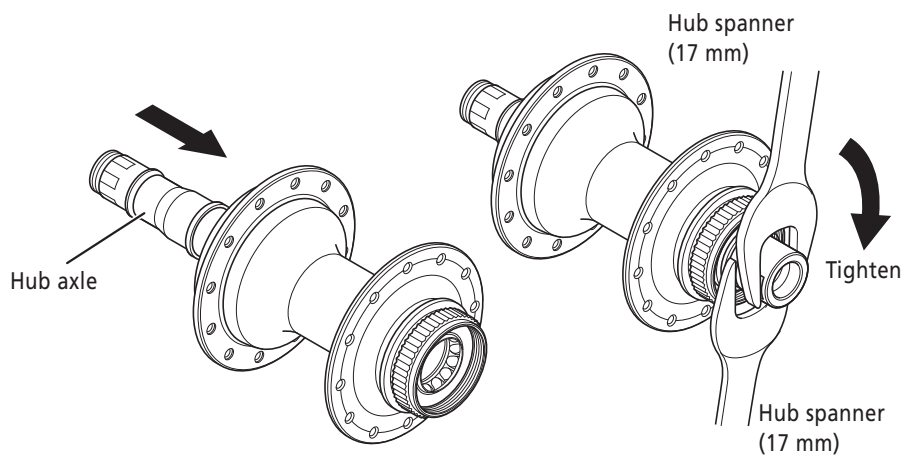

**Tightening torque:  
10 - 15 N·m**

2. Install the freewheel body.  
After installing the freewheel body, check that the lip of the seal ring is not facing the wrong way.

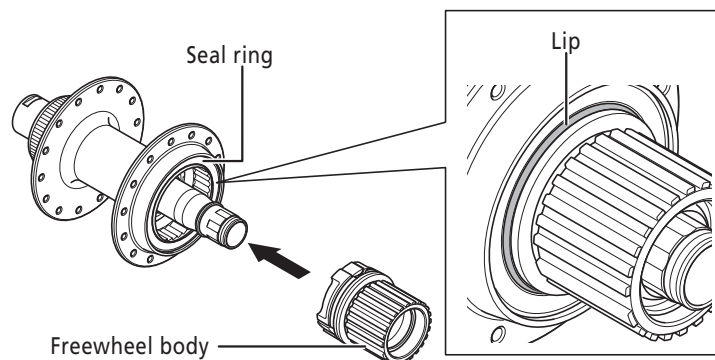

**3.** Insert the outer seal cap into the grooved part and install it.

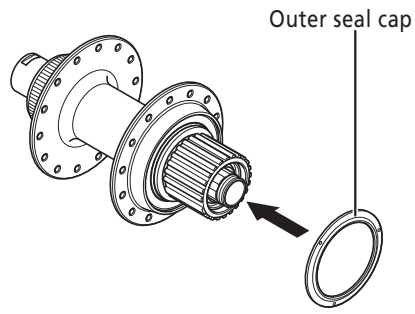

**4.** Install the right cap.  
Be sure to push it until it connects with a click.

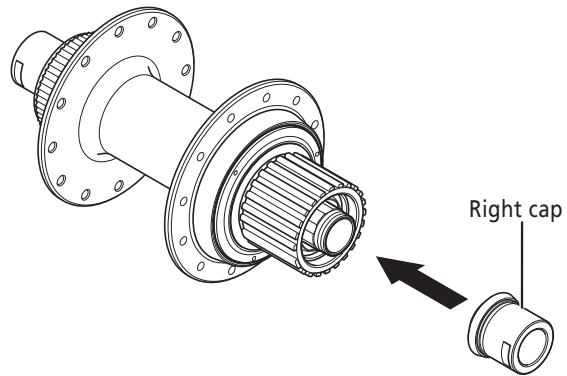

## ■ Disassembly and Assembly < Quick release type >

WH-MT15-A-275 < Front >

### NOTICE:

- The front hub cannot be disassembled from the left side of the hub unit (the side with the disc brake rotor fixing spline).
- When removing and installing the seal, do it very carefully so that the seal does not become bent. When reinstalling the seal, make sure that it is facing the right way, and insert it as far as it will go.
- Do not disassemble the dust-proof cover which is crimped onto the hub axle.

### < Disassembly >

These units can be disassembled as shown in the illustrations. Grease should be applied to each part at periodic intervals.

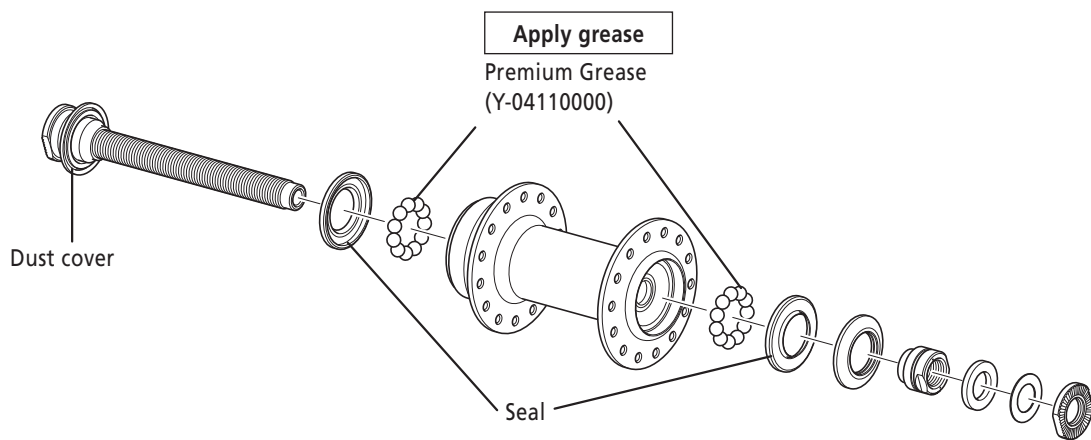

### < Assembly >

Install the hub axle, and then use the SHIMANO original tools to tighten the lock nut so as to double lock the mechanism as shown in the illustration.

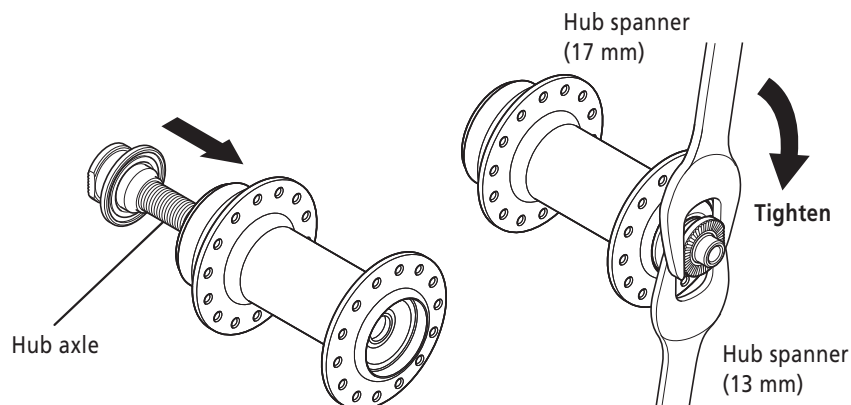

Tightening torque:  
15 - 20 N·m

**NOTICE:**

- When removing and installing the seal, do it very carefully so that the seal does not become bent. When reinstalling the seal, make sure that it is facing the right way, and insert it as far as it will go.
- Do not disassemble the dust-proof cover which is crimped onto the cone.
- Do not attempt to disassemble the freewheel body, because it may result in a malfunction.

**< Disassembly >**

The unit can be disassembled as shown in the illustration. Apply grease to the various parts at periodic intervals.

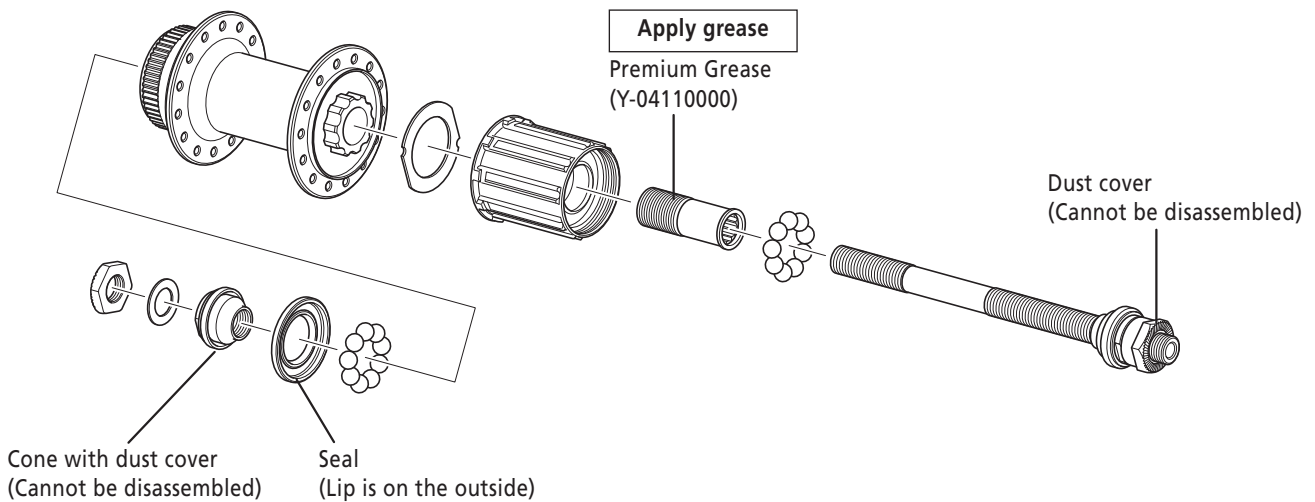

**< Assembly >**

Install the hub axle, and then use the SHIMANO original tools to tighten the lock nut so as to double lock the mechanism as shown in the illustration.

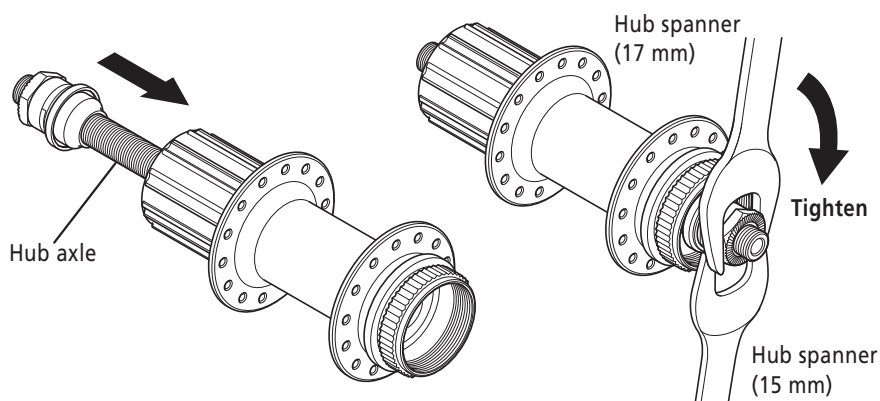

**Tightening torque:  
10 - 15 N·m**

## ■ Replacement of the freewheel body < Quick release type >

After removing the hub axle, remove the freewheel body fixing bolt (inside the freewheel body), and then replace the freewheel body.

### NOTICE:

Do not attempt to disassemble the freewheel body, because it may result in a malfunction.

### < MT68/MT66 >

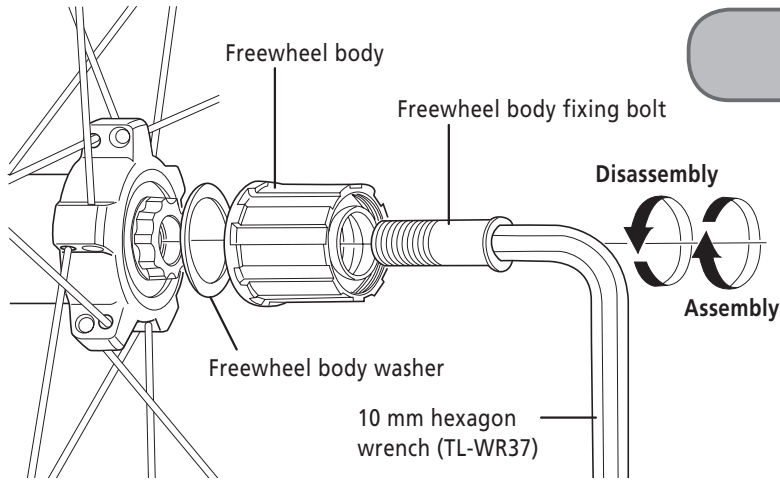

Tightening torque:  
35 - 50 N·m

### < MT35/MT15-A >

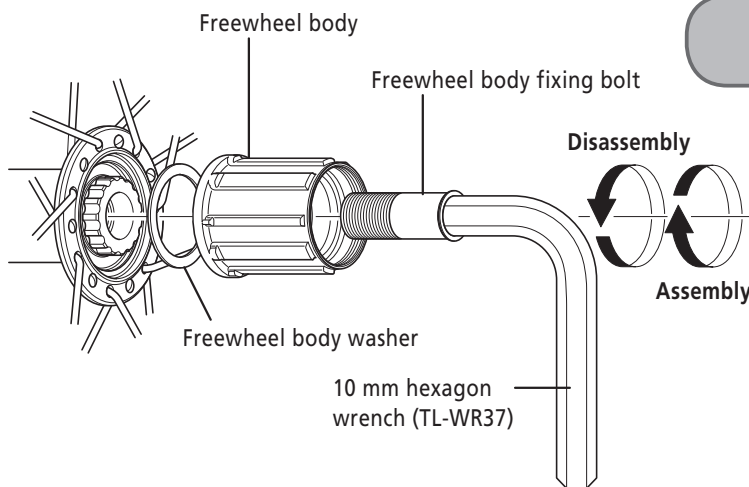

Tightening torque:  
35 - 50 N·m

## ■ Replacement of the freewheel body < Thru axle type >

MT68/MT66/MT600

1. First, pull out the hub axle by following the procedure shown in the illustration.  
The double-lock section at the freewheel side cannot be disassembled.

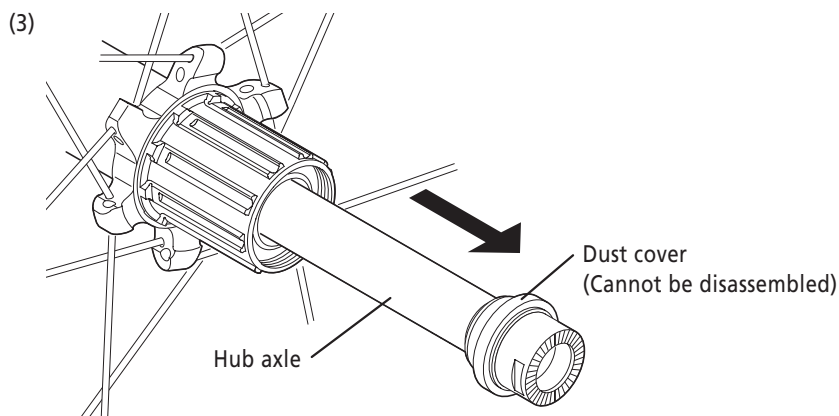
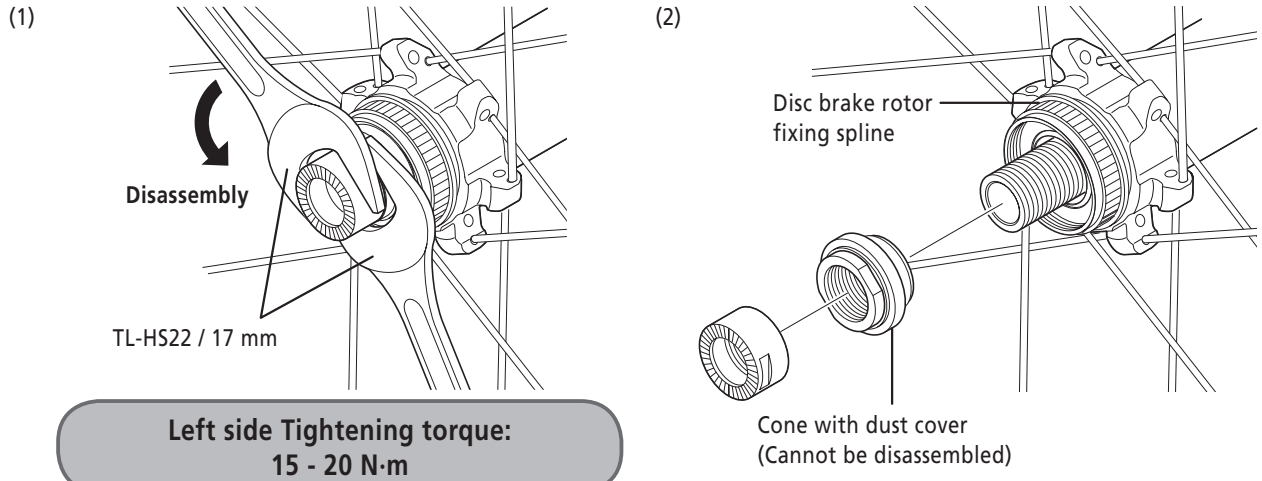

2. After removing the hub axle, remove the freewheel body fixing bolt (inside the freewheel body), and then replace the freewheel body.

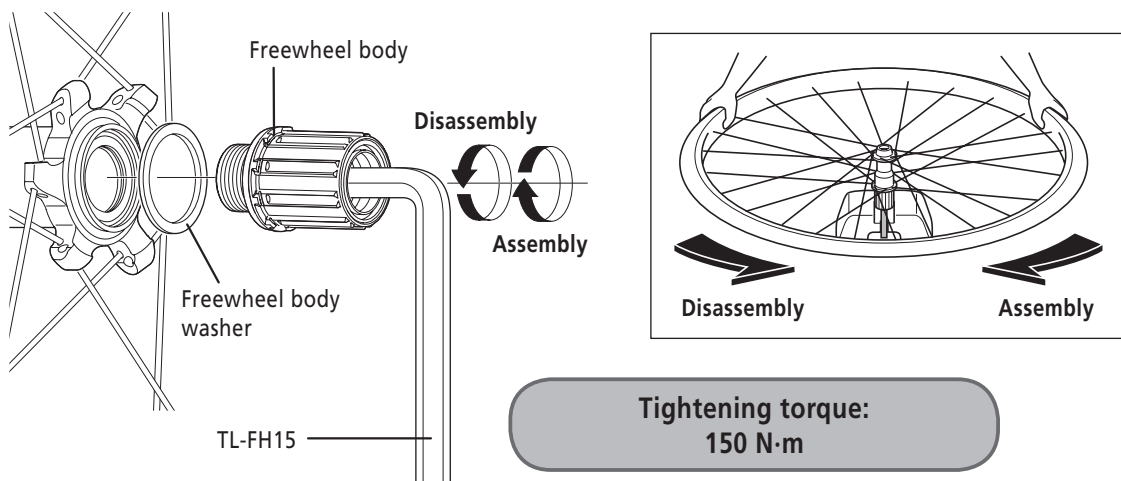

1. Remove the right cap.

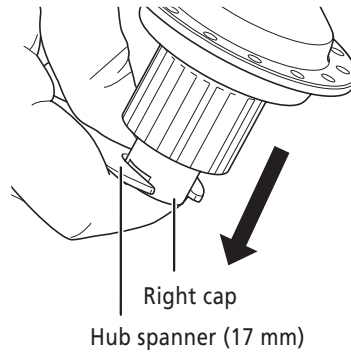

2. Pull out the freewheel body and replace it.

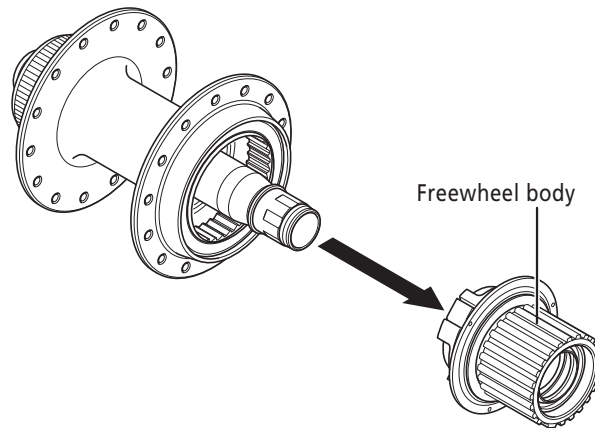

# Type-A : Type that uses covering tape and rim hole caps

## ■ Replacing the covering tape and rim hole caps

< WH-MT66/MT66-29/MT68 >

Common to tubeless tires and clincher tires

- The covering tape cannot be reused. Use a new one when replacing it.
- Use a covering tape matching the rim width.
- It is recommended that you use genuine SHIMANO covering tape and rim hole caps to prevent punctures and other possible damages.

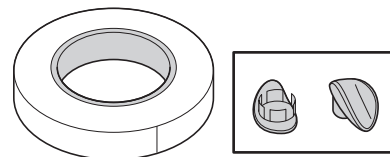

Covering tape and rim hole caps

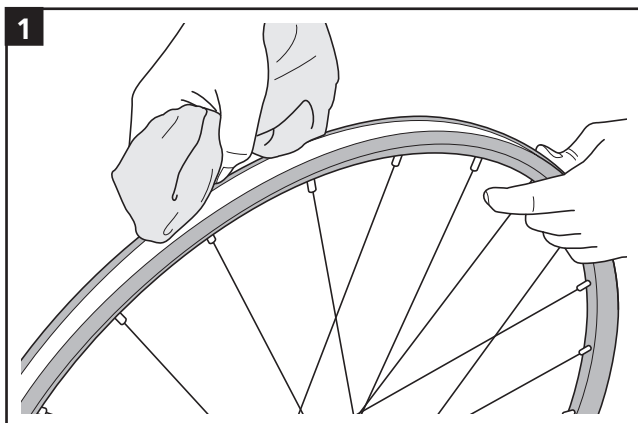

When using a sealant, wipe it off completely (it can be washed off with water).

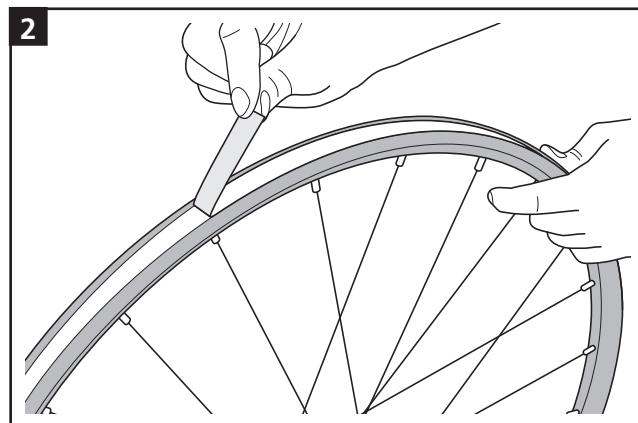

Remove the covering tape.

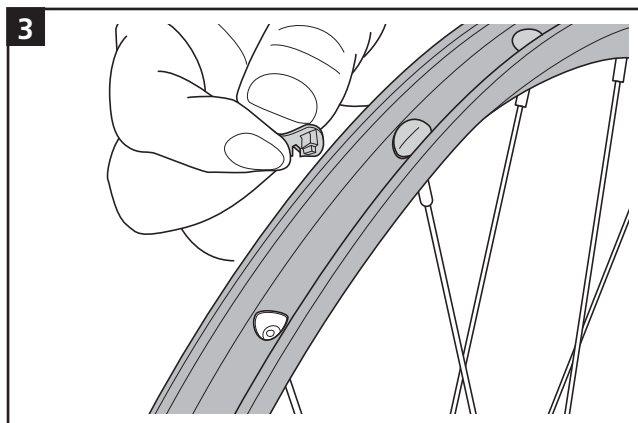

Remove the rim hole cap.

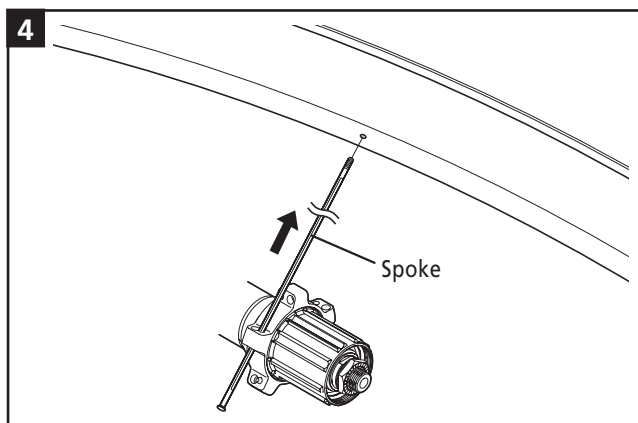

Replace the spokes.

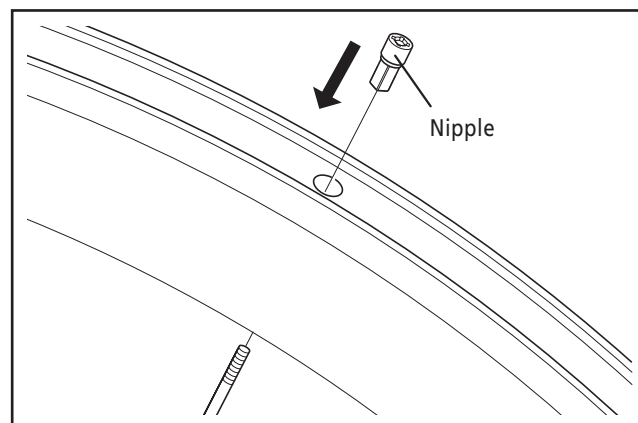



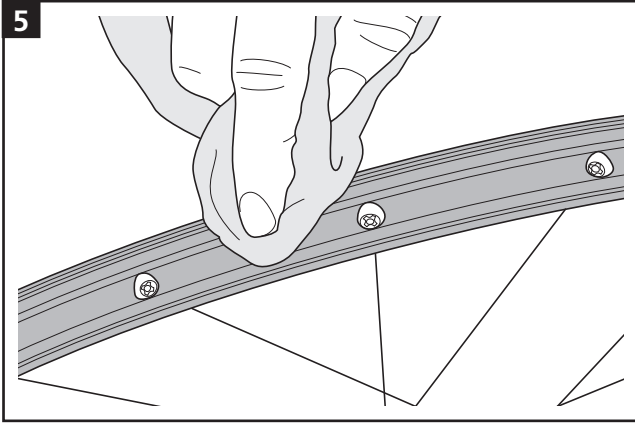

5 Clean the rim hole and the rim surface where the tape is affixed.

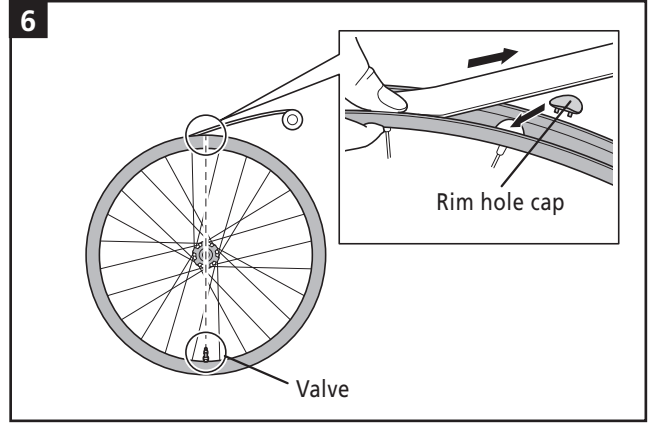

6 Affix a new covering tape while attaching the rim hole cap.  
 \* Start affixing the tape from the opposite side of the valve and finish by overlapping the tape.  
 \* Affix the covering tape so that it is not off to one side, but right in the middle of the rim, as shown in the following illustration.



\* Pull the tape with your hand to some extent when affixing it.  
 \* Do not use a tool (use your hand). Otherwise, the tape may become torn.

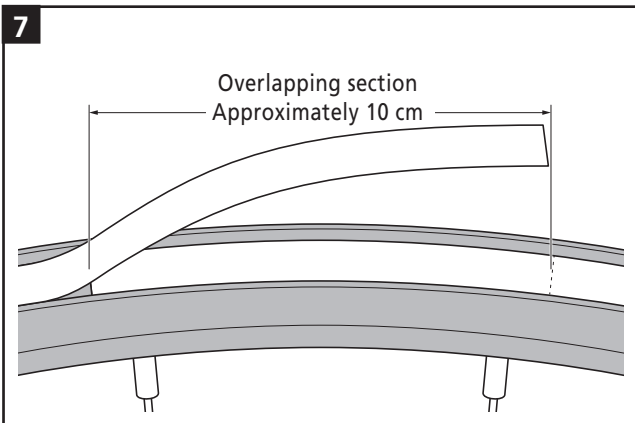

7 Closely attach the tape on the rim from end to end.

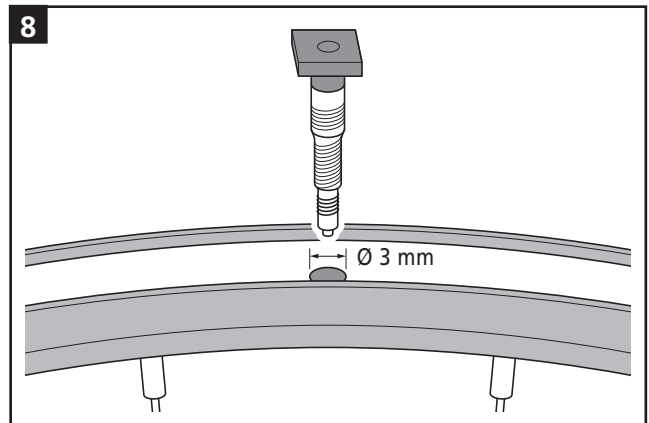

8 Finally, drill a pilot hole with a diameter of 3 mm in the valve hole section and then attach the valve.

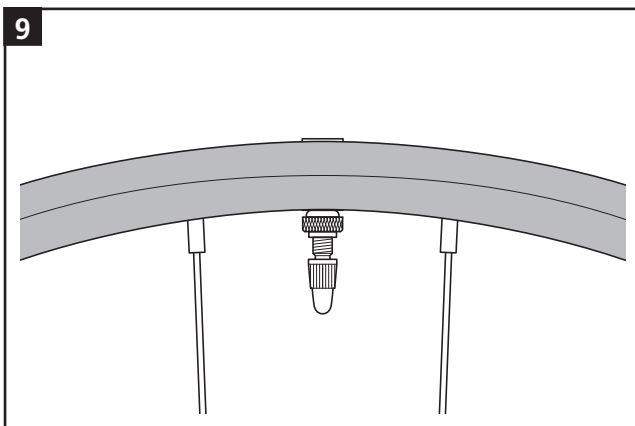

9

## Type-B : Type that uses only tubeless tape and does not require rim hole caps

### ■ Replacing tubeless tape

< WH-MT66/MT66-29/MT68/MT501/MT600/MT620 >

Common to tubeless tires and clincher tires

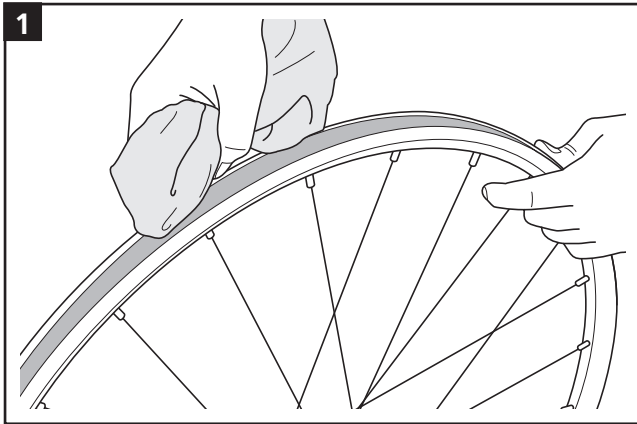

When using a sealant, wipe it off completely.

NOTICE: The tubeless tape cannot be reused. Use a new one when replacing it.

- Use a tubeless tape matching the rim width.
- It is recommended that you use genuine SHIMANO tubeless tape to prevent punctures and other possible damages.

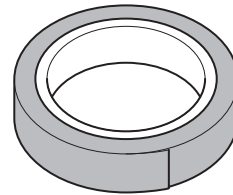

Tubeless tape

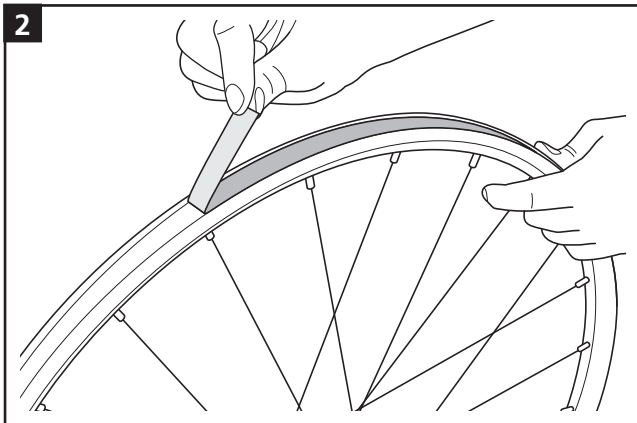

Remove the tubeless tape.

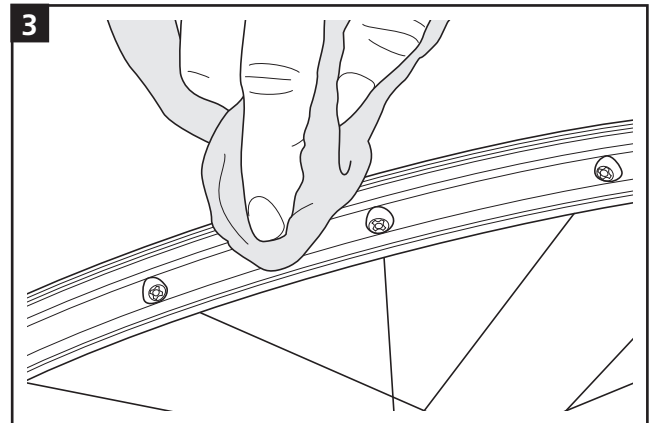

Clean the rim hole and the rim surface where the tape is affixed.

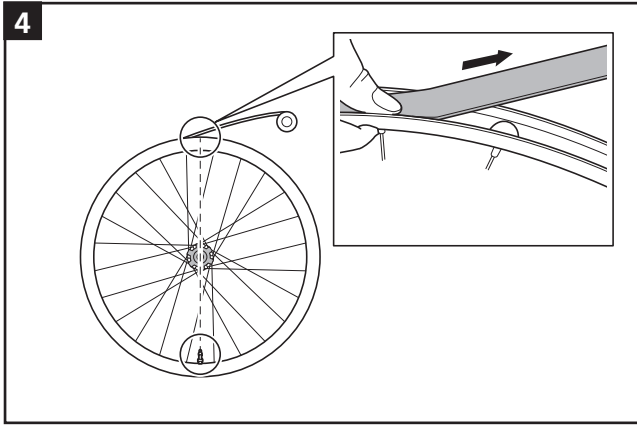

Affix a new tubeless tape. Start affixing the tape from the opposite side of the valve.

\* Affix the tubeless tape in the middle of the rim, not off to one side, as shown in the following illustration.



\* Because the tape may tear, do not use a tool (use your hand) to affix the tape. Pull the tape with your hand to some extent when affixing it.

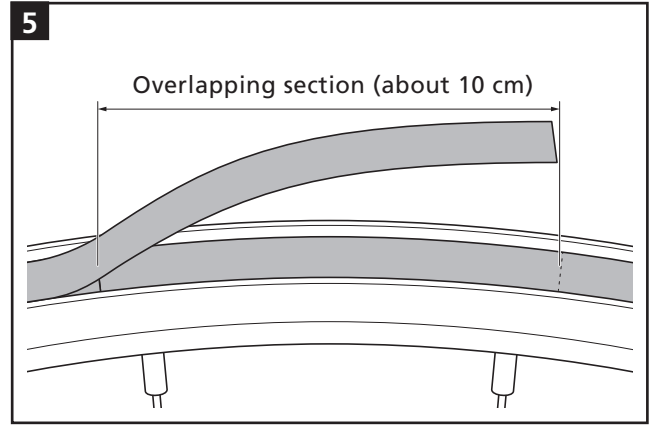

Overlap the ends of the tape by about 10 cm. Securely attach both ends of the tape to the rim.

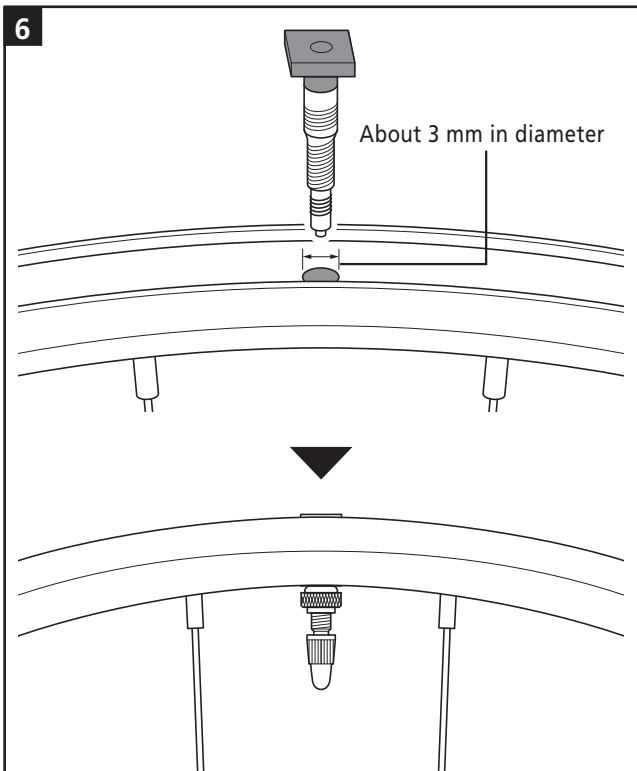

Drill a pilot hole with a diameter of 3 mm in the valve hole section and then attach the valve.

## ■ How to use a sealant (In the case of type-A)

Product name	Wheel Sealant
Volume	300 mL
Ingredients	Propylene glycol, chemical fibers, rust-preventive agent, preservatives
Intended purpose	This sealant is used to convert SHIMANO "Sealing Tape Tubeless System" wheels into a tubeless type. It is not intended to prevent punctures or repair tires.

### TO ENSURE SAFETY

#### ⚠ WARNING

- Use this product only after carefully reading through all instructions and fully understanding them.
- Do not ingest this product. In the event of accidental swallowing, drink a lot of water and promptly seek medical consultation.
- Protect your eyes with goggles or other devices when using this product. If the product comes into contact with an eye, rinse your eye thoroughly with water and promptly seek medical consultation.

#### NOTICE

- Do not mix this product with another product for use.
- The valve should be facing upward when inflating tires. The sealant may leak if the valve is facing down.
- Do not use an air gauge to deflate tires. The sealant may leak, which can cause damage to the air gauge.
- This product can be easily cleaned off by rinsing with water.
- If you are unsure about any of the information contained in this label, contact the place of purchase or a bicycle dealer.
- Dealer's manuals can be viewed online on our website (<https://si.shimano.com>).

#### STORAGE AND DISPOSAL

- Avoid direct sunlight and store in a well-ventilated place with the inner lid and cap properly attached.
- Store out of the reach of children.
- Dispose of the container after it has been emptied or all of the content has been consumed.

### HOW TO USE

1. Using a valve core remover (supplied with the wheels) to remove the valve core.

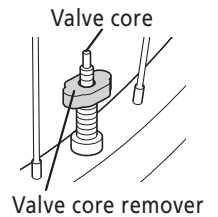

2. Place the valve adapter of the hose over the valve.

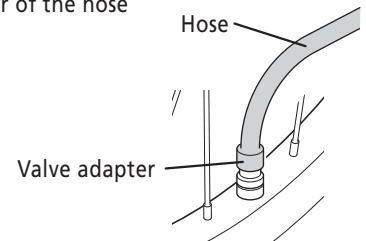

3. Remove the cap and inner lid from the sealant container and insert the injector cap into the hose.

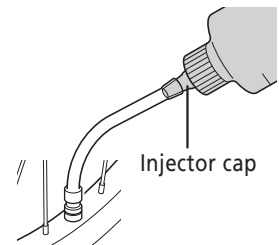

4. Supply the specified amount of sealant.  
Sealant amount guide: 100 mL for 26-inch tires,  
150 mL for 29-inch tires

5. Securely re-attach the valve core and put the specified amount of air into the tire.

6. Turn the wheel to spread the sealant throughout the tire.

7. Check for air escape from the wheel after leaving the wheel for several hours.

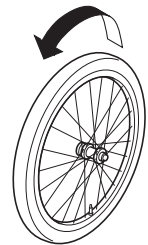

# ■ Installing and removing tubeless tires

## TO ENSURE SAFETY

### ⚠ WARNING

- Read this manual carefully, and keep it in a safe place for later reference.
- The tires should be installed and removed by hand. If this is difficult, a plastic tire lever for tubeless wheels may be used. In such cases, be sure to check that the rim surface has not been dented, scratched, or cracked as there is a risk of causing damage to the air seal between the tire and the rim, which would result in air leakage. For carbon rims, check that there is no carbon peeling or cracking etc. Finally, make sure there is no air leakage.

### ⚠ CAUTION

- Do not use rim tape if using an inner tube either. Rim tape may make it difficult to remove and install the tire, and the tire or tube may become damaged or the tires may suddenly puncture and come off, and severe injury may result.
- Do not tighten the valve nut too much, otherwise the valve seal may become warped and air leaks may occur.

### NOTICE

- If the tires are difficult to fit, use plain water or soapy water to help them slide more easily.
- When you use a type-A wheel, if the tire is difficult to attach or fill with air, apply the sealant on the bead section.
- Products are not guaranteed against natural wear and deterioration from normal use and aging.

## HOW TO USE

### 1. Installing tubeless tire valves

- Install the valve so that it faces as shown in the illustration.

When tightening the valve nut, check that the valve does not turn together with the valve nut.

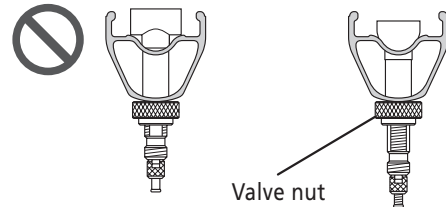

### 2. Installing the tires

- Insert the bead on one side of the tire as shown in the illustration.

Check that there are no foreign particles in the tire bead, rim and valve at this time.

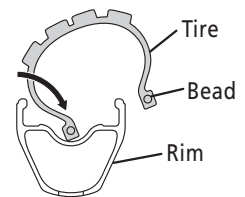

- Insert the bead on the other side of the tire starting from the point opposite the air valve.

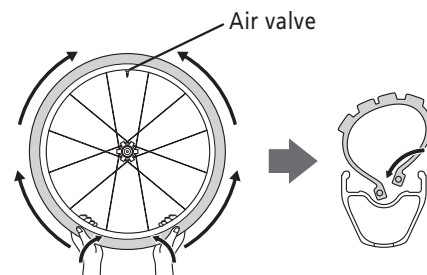

It will become more difficult to insert the bead at the side of the air valve. In such cases, lift up the bead by hand starting from the opposite side of the tire, and work your way around to the location of the air valve.

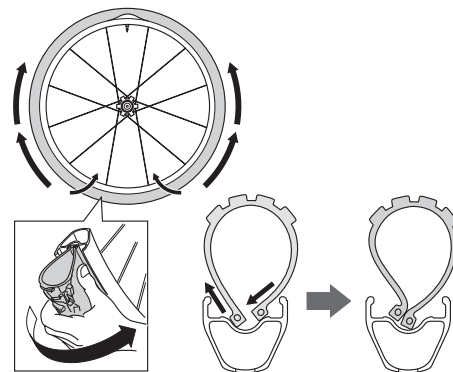

Lastly, grip the tire with both hands as shown in the illustration and insert the tire into the rim.

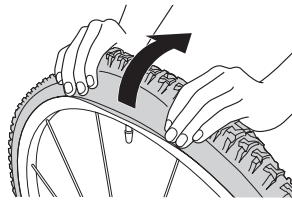

Inflate with air to lock the beads of the tires into the rim as shown in the illustration.

After this, deflate the tire and check that the bead is locked into the rim.

Then re-inflate the tire to the standard air pressure for use.

If the bead is not locked into the rim, the bead is separating from the rim when the tire is deflated.

(Max : 400 kPa/58 psi)

### 3. Removing the tires

- To remove a tire, deflate the tire and then push the bead on one side of the tire into the gorge of the rim as shown in the illustration.

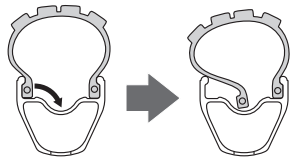

#### NOTICE:

Be sure to only push in the bead on one side of the tire. If you push the beads in on both sides, the tires will be difficult to remove. If you push in the beads on both sides, inflate the tire once more to lock the beads, and then remove the tire by starting the procedure from the beginning again.

- Remove the bead on one side of the tire starting from the point closest to the air valve, and then remove the bead on the other side of the tire.

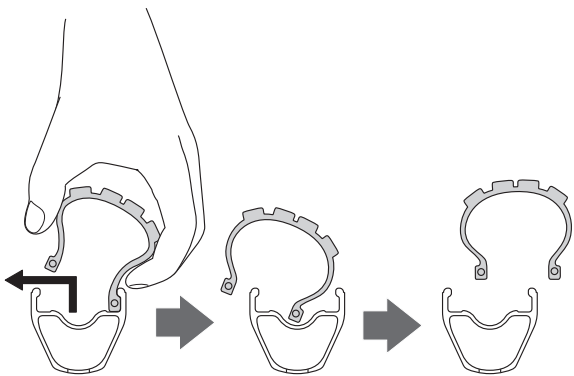

### 4. Notes when using inner tubes

- Loosen the locking ring of the air valve and remove the air valve.
- Insert the bead on one side of the tire as shown in the illustration.



- Liberalily moisten the outer edges of the rim and the tire beads, and place the slightly-inflated inner tube inside the tire so that it can slide smoothly.
- Check that the air valve of the inner tube is appropriate for use with the rim.
- Insert the bead on one side of the tire starting from the side of the rim opposite the air valve. Be careful not to pinch the tube at this time. If necessary, use soapy water.
- Inflate the inner tube until the tire locks into place.
- Do not use rim tape if using an inner tube either. Rim tape may make it difficult to remove and install the tire, and the tire or tube may become damaged or the tires may suddenly puncture and come off, and severe injury may result.
- Contact your dealer for the specifications of inner tubes that can be used.

# SHIMANO

**SHIMANO NORTH AMERICA BICYCLE, INC.**

One Holland, Irvine, California 92618, U.S.A. Phone: +1-949-951-5003

**SHIMANO EUROPE B.V.**

High Tech Campus 92, 5656 AG Eindhoven, The Netherlands Phone: +31-402-612222

**SHIMANO INC.**

3-77 Oimatsu-cho, Sakai-ku, Sakai City, Osaka 590-8577, Japan

Please note: specifications are subject to change for improvement without notice. (English)

© Aug. 2020 by SHIMANO INC. ITP