

Dealer's Manual

ROAD	MTB	Trekking
City Touring/ Comfort Bike	URBAN SPORT	E-BIKE

Front derailleur

METREA
FD-U5000

CONTENTS

IMPORTANT NOTICE	3
TO ENSURE SAFETY	4
LIST OF TOOLS TO BE USED	6
INSTALLATION.....	8
Installation of the front derailleur (direct mount type).....	8
■ Mounting the backup plate.....	8
■ Installing the front derailleur	9
Installation of the front derailleur using a band adapter (SM-AD90/79/67).....	10
ADJUSTMENT.....	13
Connecting and securing the inner cable	13
■ Adjusting the cable route	13
■ Securing the cable	16
Low adjustment	18
Adjustment of cable tension.....	18
Top adjustment	19
Checking gear shifting and minor adjustments.....	20
MAINTENANCE	22
Replacing the skid plate	22
■ Removing the skid plate	22
■ Mounting the skid plate	22

IMPORTANT NOTICE

- **This dealer's manual is intended primarily for use by professional bicycle mechanics.**

Users who are not professionally trained for bicycle assembly should not attempt to install the components themselves using the dealer's manuals.

If any part of the information on the manual is unclear to you, do not proceed with the installation. Instead, contact your place of purchase or a local bicycle dealer for their assistance.

- Make sure to read all instruction manuals included with the product.
- Do not disassemble or modify the product other than as stated in the information contained in this dealer's manual.
- All dealer's manuals and instruction manuals can be viewed on-line on our website (<http://si.shimano.com>).
- Please observe the appropriate rules and regulations of the country, state or region in which you conduct your business as a dealer.

For safety, be sure to read this dealer's manual thoroughly before use, and follow it for correct use.

The following instructions must be observed at all times in order to prevent personal injury and physical damage to equipment and surroundings.

The instructions are classified according to the degree of danger or damage which may occur if the product is used incorrectly.

DANGER

Failure to follow the instructions will result in death or serious injury.

WARNING

Failure to follow the instructions could result in death or serious injury.

CAUTION

Failure to follow the instructions could cause personal injury or physical damage to equipment and surroundings.

TO ENSURE SAFETY

WARNING

- Be sure to follow the instructions provided in the manuals when installing the product.

It is recommended to use genuine Shimano parts only. If parts such as bolts and nuts become loose or damaged, the bicycle may suddenly fall over, which may cause serious injury.

In addition, if adjustments are not carried out correctly, problems may occur, and the bicycle may suddenly fall over, which may cause serious injury.

-  Be sure to wear safety glasses or goggles to protect your eyes while performing maintenance tasks such as replacing parts.
- After reading the dealer's manual thoroughly, keep it in a safe place for later reference.

Be sure to also inform users of the following:

- Be careful not to let the hemming of your clothes get caught in the chain while riding. Otherwise you may fall off the bicycle.

NOTE

Be sure to also inform users of the following:

- If gear shifting operations cannot be carried out smoothly, clean the derailleur and lubricate all moving parts.
- When the chain is in any of the positions shown in the illustration, the chain may come into contact with the front chainring or front derailleur and generate noise. If the noise is a problem, shift the chain onto the next largest sprocket or the one after.

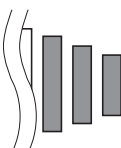
	Double
Chainring	
Sprocket	

- Products are not guaranteed against natural wear and deterioration from normal use and aging.
- For maximum performance we highly recommend Shimano lubricants and maintenance products.

For Installation to the Bicycle, and Maintenance:





- Use an OT-SP cable and cable guide for smooth operation.
- If looseness in the links is so great that gear shifting adjustments cannot be made, replace the derailleur.

The actual product may differ from the illustration because this manual is intended mainly to explain the procedures for using the product.

LIST OF TOOLS TO BE USED

LIST OF TOOLS TO BE USED

The following tools are needed for installation, adjustment, and maintenance purposes.

Tool		Tool		Tool	
	2 mm hexagon wrench		5 mm hexagon wrench		TL-FD68
	4 mm hexagon wrench		Screwdriver[#2]		

INSTALLATION

INSTALLATION

Installation of the front derailleur (direct mount type)

NOTE

- With a carbon frame, even the recommended tightening torque may be too tight and cause damage to the frame, or too loose and not sufficiently attached to the frame. For the appropriate torque value, consult with the manufacturer of the completed bicycle or the manufacturer of the frame.
- When installing a direct mount front derailleur, it is recommended to attach a support bolt to ensure optimum performance of the front derailleur. When a support bolt is attached, there is a risk that it will cause to damage the frame; therefore, be sure to attach a backup plate.
(However, in some cases a support bolt and backup plate cannot be attached.)

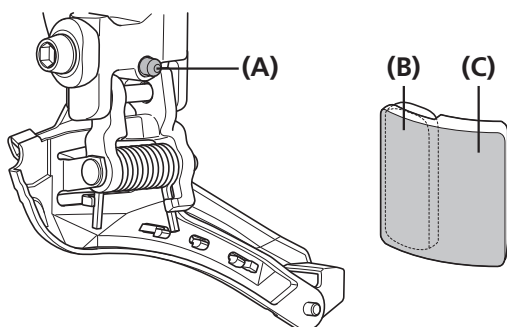

- (A) Support bolt
- (B) Tape
- (C) Backup plate

■ Mounting the backup plate

Either 2 backup plates (a plate with a curved adhesion surface [1] and a plate with a flat surface [2]) or 1 backup plate (curved surface only [1]) will be included.

If 2 plates are included, use whichever type matches the shape of the frame.



- (A) Tape

1. Check where the support bolt makes contact with the seat tube when adjusting the front derailleur support bolt.

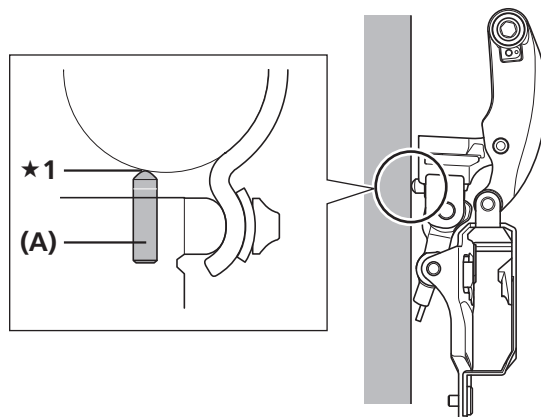

- ★1 Location where support bolt touches seat tube
- (A) Support bolt

2. Check the position where the support bolt directly touches the frame when the support bolt of the front derailleur is being adjusted, and attach the backup plate in that position. In addition, avoid positioning the tape that attaches the backup plate to the seat tube in the location where the support bolt directly touches the frame.

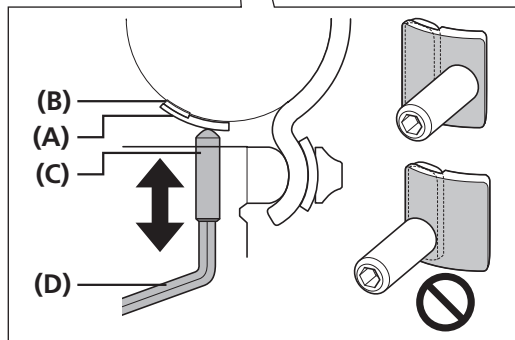
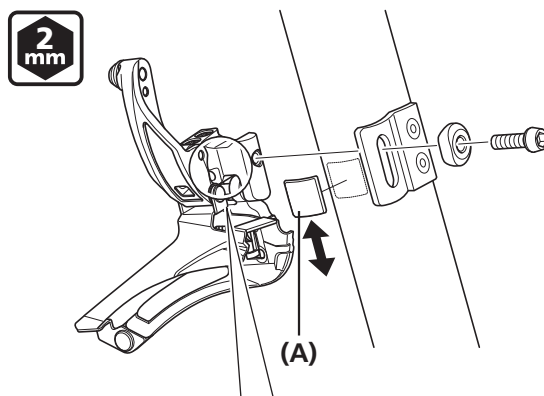

- (A) Backup plate
- (B) Tape
- (C) Support bolt
- (D) 2 mm hexagon wrench

■ Installing the front derailleur

1. After tentatively tightening the clamp bolt, adjust the low adjustment bolt and align the front end of the outer plate of the chain guide parallel to the surface of the largest chainring.
At this point, adjust the chain guide so that its rear end is 0.5 - 1 mm inside.

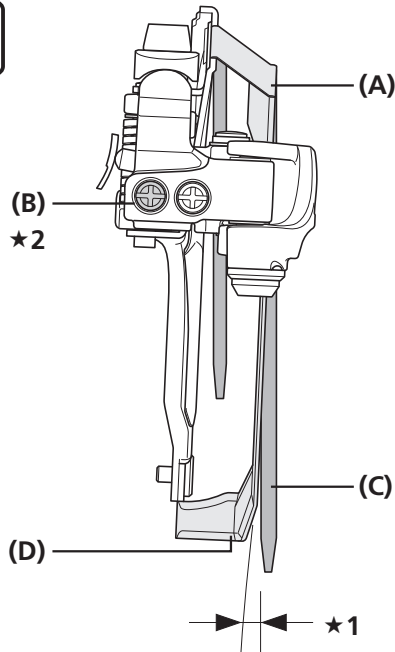

$\star 1$ 0.5 - 1 mm

$\star 2$ Screwdriver[#2]

- | | |
|-----|--------------------------------------|
| (A) | Front end of chain guide outer plate |
| (B) | Low adjustment bolt |
| (C) | Largest chainring |
| (D) | Rear end of chain guide |

2. Adjust so that there is a clearance of 1 - 3 mm between the chain guide outer plate and the largest chainring.

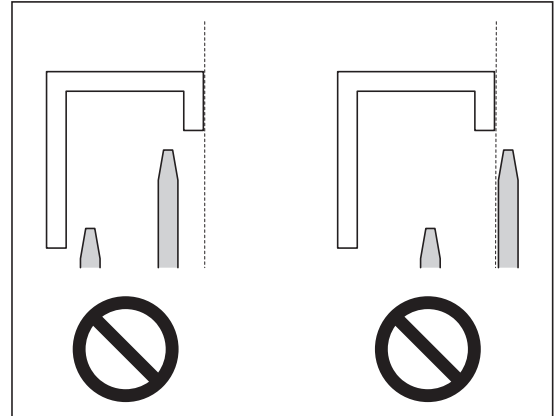
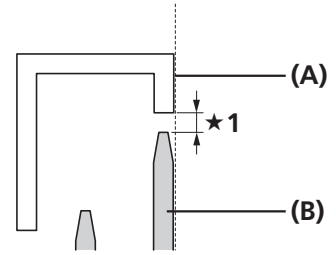

$\star 1$ 1 - 3 mm

- | | |
|-----|-------------------------|
| (A) | Chain guide outer plate |
| (B) | Largest chainring |

3. When the adjustment is complete, tighten the clamp bolt.

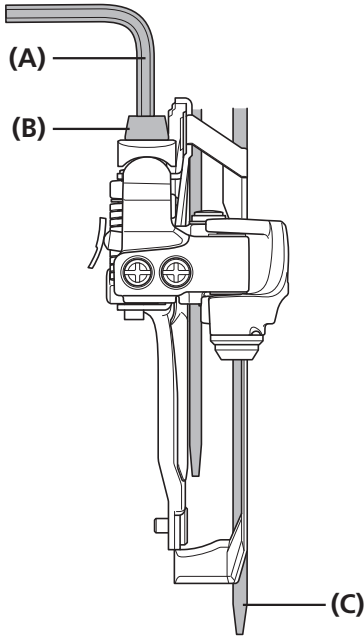

- (A) 5 mm hexagon wrench
- (B) Clamp bolt
- (C) Largest chainring

Tightening torque

5 mm hexagon wrench

5 - 7 N·m

4. Adjust the support bolt so that the flat portion of the outer plate of the chain guide is parallel to the surface of the largest chainring.

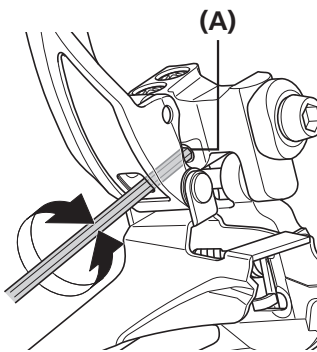

- (A) Support bolt

Installation of the front derailleur using a band adapter (SM-AD90/79/67)

Use a support bolt and backup plate even when installing the front derailleur using a band adapter (SM-AD90/79/67). Refer to "Installation of the front derailleur (direct mount type)" for details on use.

1. Mount the band adapter (SM-AD90/79/67) on to the front derailleur.

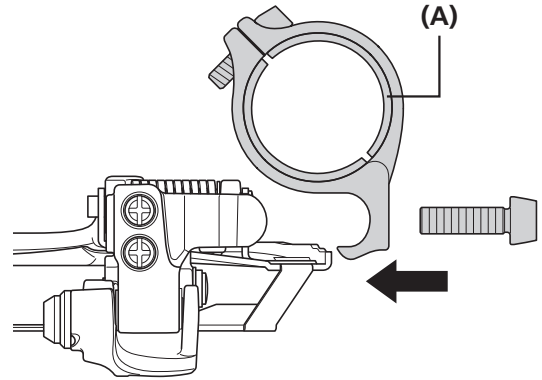

- (A) Band adapter

2. After tentatively tightening the clamp bolt, adjust the low adjustment bolt and align the flat portion of the chain guide outer plate parallel to the surface of the largest chainring.

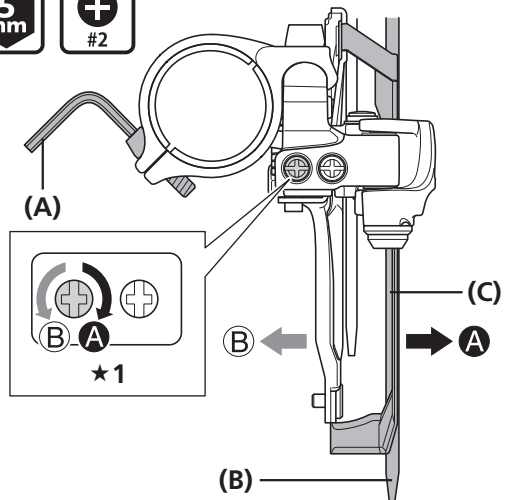

★1 Screwdriver[#2]

- (A) 5 mm hexagon wrench
- (B) Largest chainring
- (C) Chain guide

3. Adjust so that there is a clearance of 1 - 3 mm between the chain guide outer plate and the largest chainring.

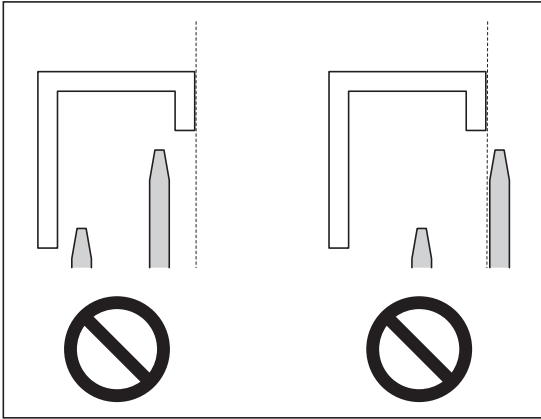
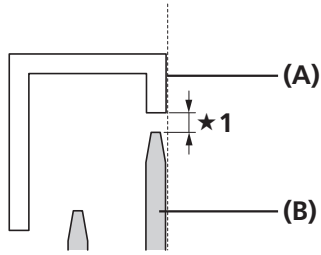

★1 1 - 3 mm

- (A) Chain guide outer plate
(B) Largest chainring

4. When the adjustment is complete, tighten the clamp bolt.

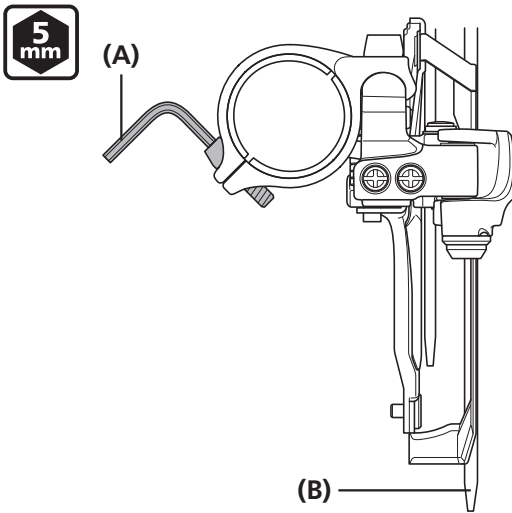

- (A) 5 mm hexagon wrench
(B) Largest chainring

Tightening torque

5 mm hexagon wrench

5 - 7 N·m

ADJUSTMENT

ADJUSTMENT

Connecting and securing the inner cable

■ Adjusting the cable route

The distance of the movement of the front derailleur varies according to the end point of the cable guide or the position of the hole in the frame through which the cable is passed. Adjust the distance of the movement by turning ON/OFF the converter.

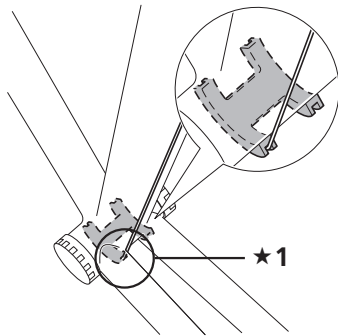

★1 End point of the cable guide

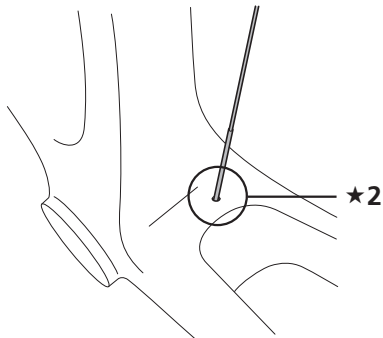

★2 Hole in the frame through which the cable is passed

Using the converter judgment tool

Use the converter judgment tool (TL-FD68) to determine the appropriate orientation for the converter.

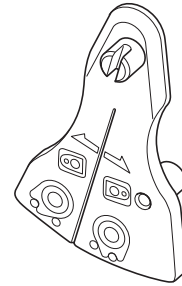

TECH TIPS

Before using the converter judgment tool, align the chain guide outer plate parallel to the surface of the largest chainring.

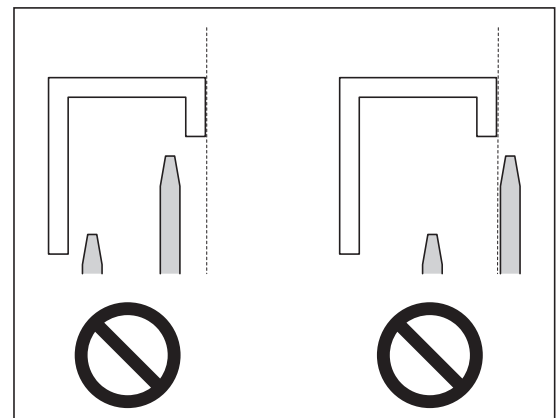
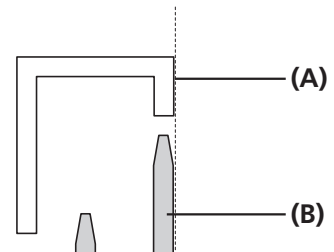

(A) Chain guide

(B) Largest chainring

1. Insert the pin in alignment with the hole in the shaft of the right-side link and the hexagonal hole in the fixing bolt.

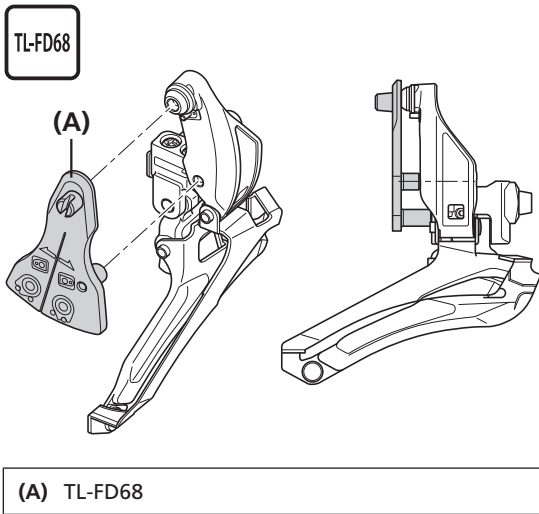

2. Pass the cable through the slit in the tool and pull the cable.
Check which side of the center line the cable is on when looking at the tool.
(Either ON or OFF can be selected if the cable is on the center line.)

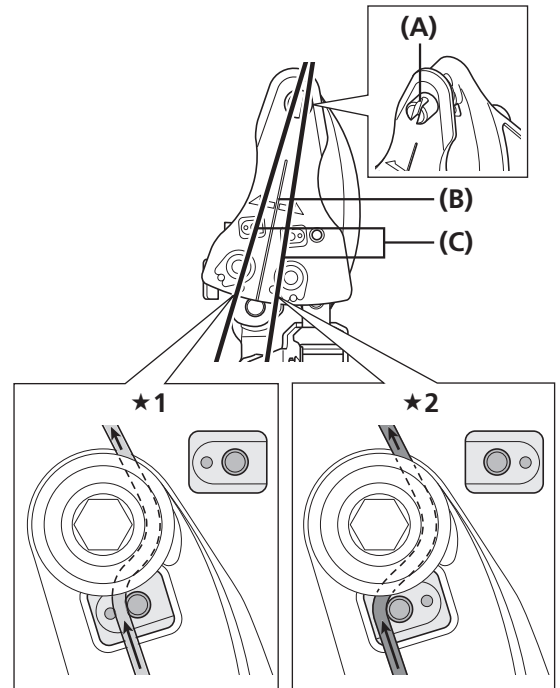

★1 Converter: OFF

★2 Converter: ON

- (A) Slit
(B) Center line
(C) Inner cable

TECH TIPS

At this point, make sure that the outer plate of the chain guide is parallel to the surface of the largest chainring.

Turning ON/OFF the converter

The protrusion on the converter and the dent beside it serve as a guide.

- The protrusion is on the outer side of the bicycle: OFF
- The protrusion is on the inner side of the bicycle: ON
(Either ON or OFF can be selected if the cable is on the center line.)

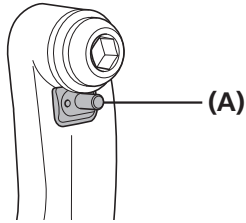

(A) Converter

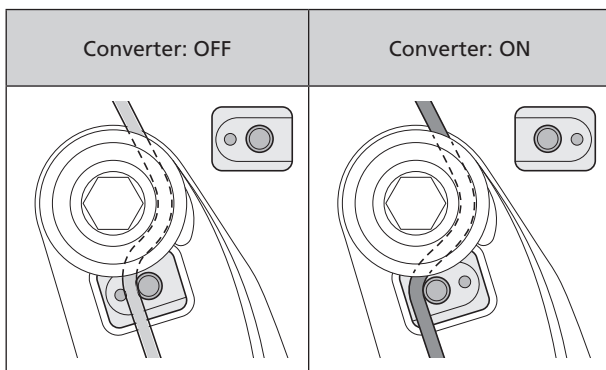

Switch between ON and OFF using a 2 mm hexagon wrench with the fixing bolt fully tightened so that the correct mounting position can be obtained.

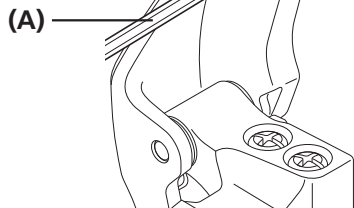

(A) 2 mm hexagon wrench

Switching from OFF to ON

1. Insert a 2 mm hexagon wrench into the converter and push out the converter until it comes into contact with the fixing plate.
(The fixing bolt does not need to be loosened.)

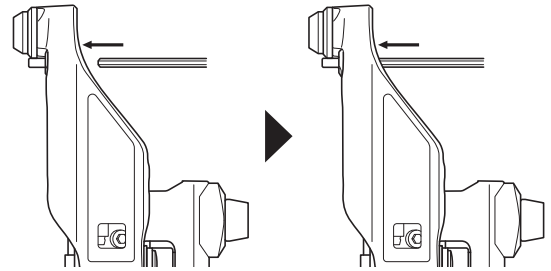

2. Turn the converter 180 degrees counterclockwise.

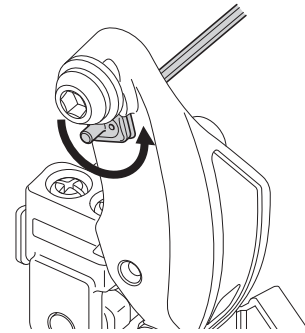

3. Push the pin of the converter back with your finger into the right-side link.

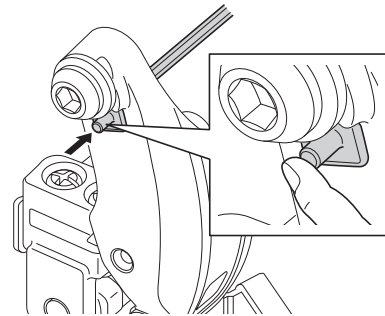

■ Securing the cable

1. Check that lever [b] is released to the L-trim position by operating it 3 or more times before securing the cable.

Lever [a]

Shifts from smallest to largest chainring

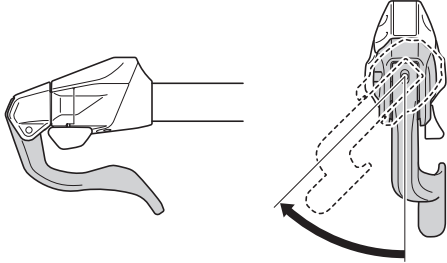

Lever [b]

Shifts from largest to smallest chainring

(Check that the lever is released to the L-trim position [1])

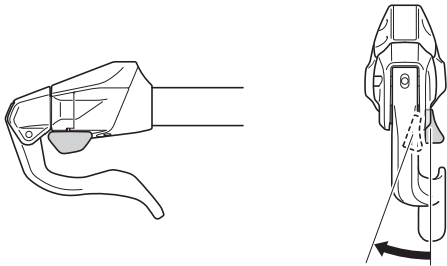

[1]

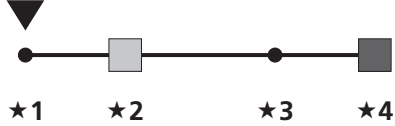

- ★1 L-trim
(cable index point)
- ★2 Low
- ★3 T-trim
- ★4 Top

2. Install the cable properly referring to the following illustration.

- If the converter is ON

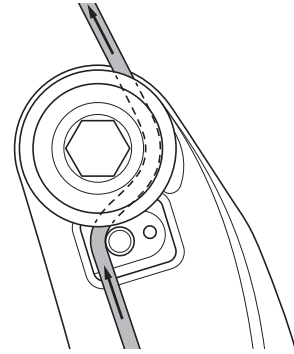

NOTE

Do not set as in the illustration below.

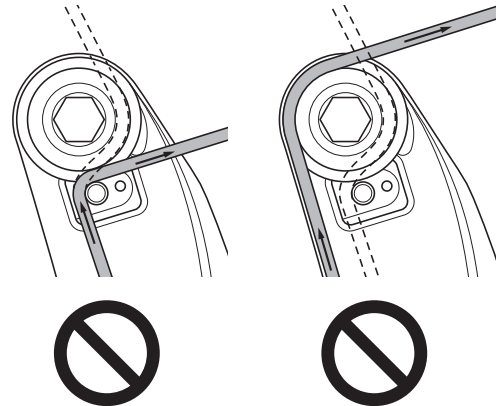

- If the converter is OFF

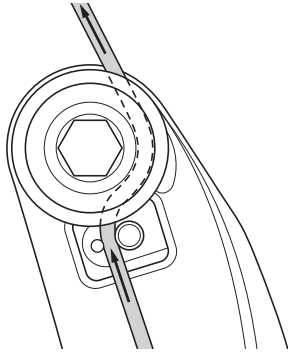

NOTE

Do not set as in the illustration below.

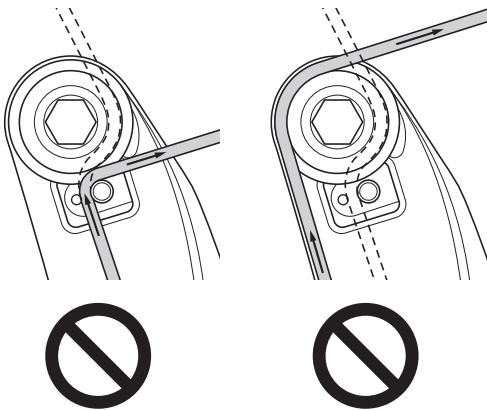

3. Fix the inner cable and remove the initial extension from the cable. After that, secure the cable again while pulling it.

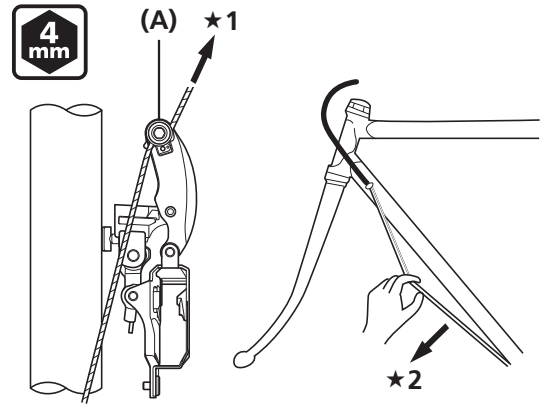

★1 Pull

★2 Remove the initial extension

(A) 4 mm hexagon wrench

Tightening torque

4 mm hexagon wrench

6 - 7 N·m

TECH TIPS

Fixing the cable with the chain guide outer plate and the surface of the largest chainring aligned, allows you to decrease the amount of cable tension adjustment when adjusting gear shifting.

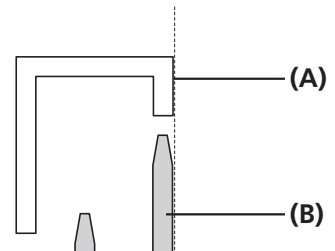

(A) Chain guide

(B) Largest chainring

Low adjustment

The gear where the lever is released from the low position to the L-trim position is the low adjustment position.

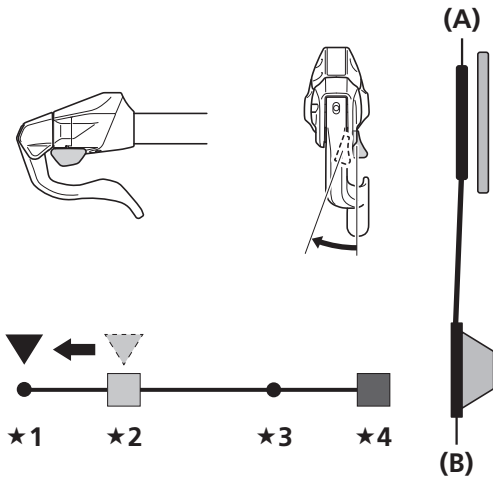

- ★1 L-trim (cable index point)
- ★2 Low
- ★3 T-trim
- ★4 Top

(A) Smallest chainring
(B) Largest sprocket

Adjustment of cable tension

The gear where the lever is released from the top position to the T-trim position is the tension adjustment position.

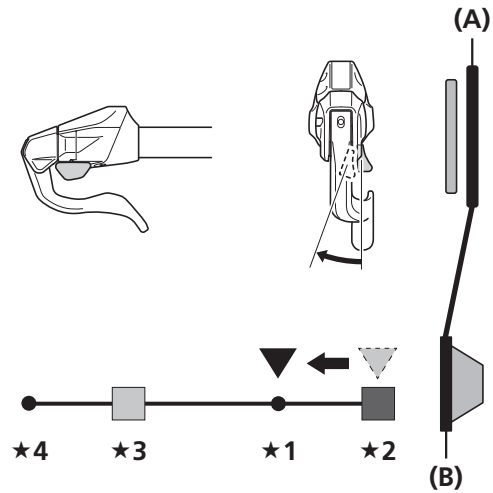

- ★1 T-trim (cable index point)
- ★2 Top
- ★3 Low
- ★4 L-trim

(A) Largest chainring
(B) Largest sprocket

1. Adjust the clearance to 0 to 0.5 mm between the skid plate of the chain guide and the chain.

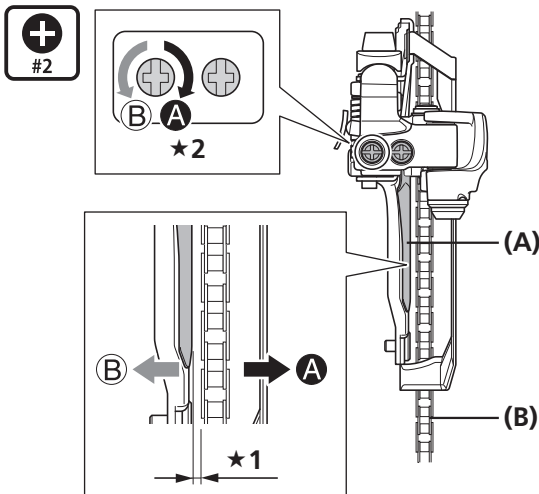

- ★1 0 - 0.5 mm
- ★2 Screwdriver[#2]

(A) Skid plate (resin part)
(B) Chain

- Adjust the clearance between the chain and the inner plate of the chain guide to the minimum (0 to 0.5 mm) using the cable adjustment barrel or cable adjuster.

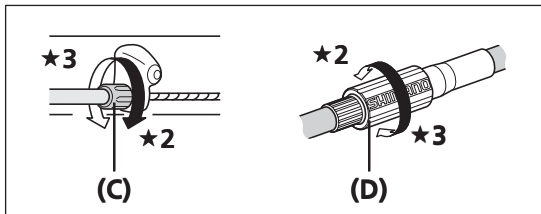
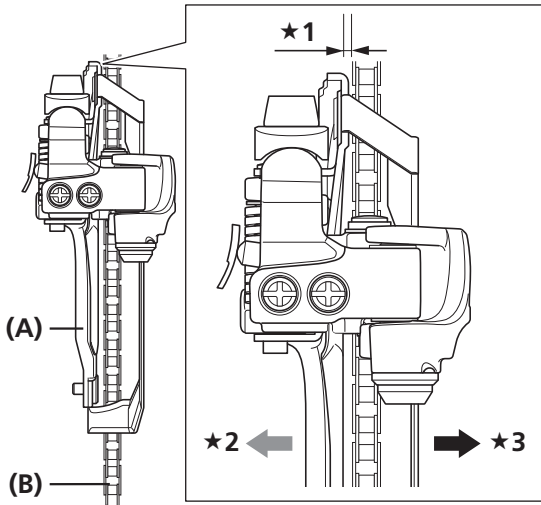

- ★1 0 - 0.5 mm
- ★2 Loosen
- ★3 Tighten

- (A) Chain guide inner plate
- (B) Chain
- (C) Cable adjustment barrel
- (D) Cable adjuster

Top adjustment

The top gear is the top adjustment position.

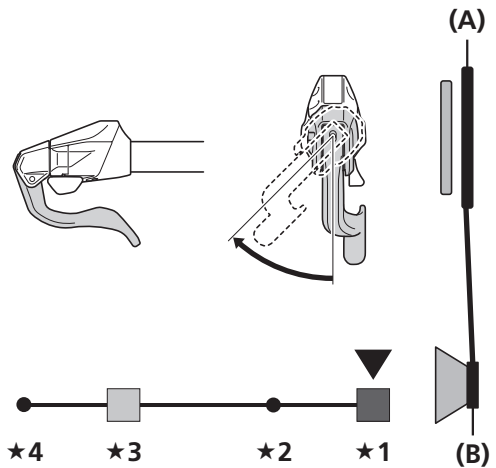

- ★1 Top (cable index point)
- ★2 T-trim
- ★3 Low
- ★4 L-trim

- (A) Largest chaining
- (B) Smallest sprocket

- Set so that the clearance between the chain guide outer plate and the chain is 0 - 0.5 mm.

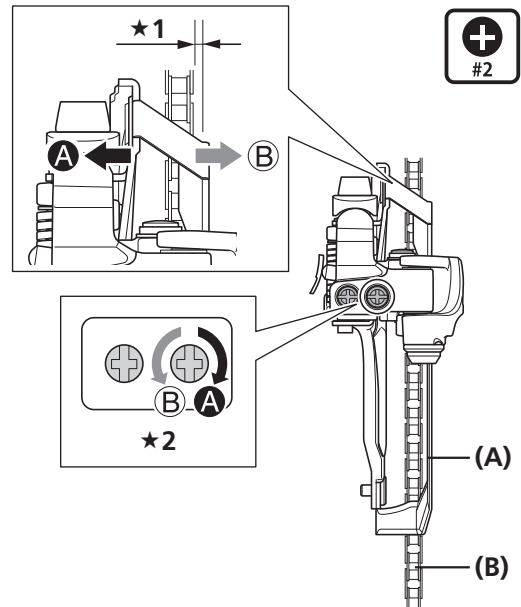

- ★1 0 - 0.5 mm
- ★2 Screwdriver[#2]

- (A) Chain guide outer plate
- (B) Chain

Checking gear shifting and minor adjustments

1. After the cable is installed and adjusted, check the gear-shift by operating the shifting lever.

(This also applies if shifting becomes difficult during use.)

* Turn the bolt by 1/8th turn for each adjustment.

If the chain falls to the crank side.	Turn the top adjustment bolt clockwise.
If shifting is difficult from the smallest chainring to the largest chainring.	Tighten the cable. If this does not improve the situation, turn the top adjustment bolt counter-clockwise.
If shifting is difficult from the largest chainring to the smallest chainring.	Loosen the cable.
If the chain falls to the bottom bracket side.	Tighten the cable. If this does not improve the situation, turn the low adjustment bolt clockwise.

MAINTENANCE

MAINTENANCE

Replacing the skid plate

■ Removing the skid plate

1. Make a slit in the skid plate at the position illustrated using pliers, and then remove the skid plate.

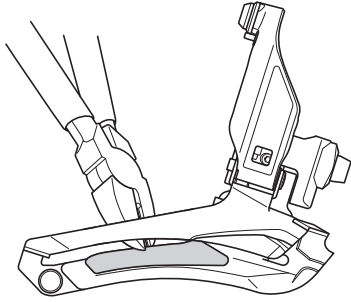

■ Mounting the skid plate

1. Insert the skid plate into the mounting holes. After insertion, check that the claws of the skid plate are engaged properly on the back side.

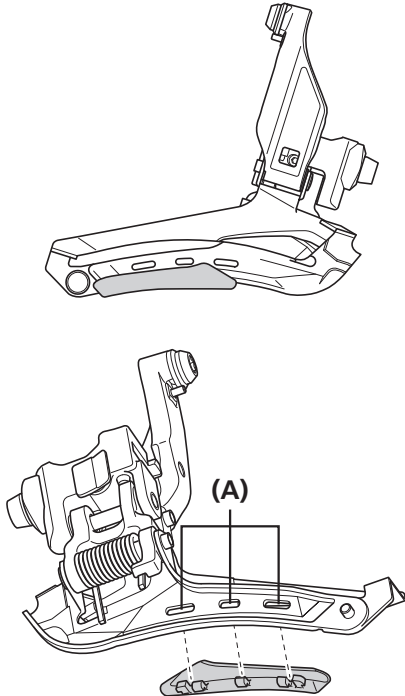

(A) Mounting holes

SHIMANO

SHIMANO NORTH AMERICA BICYCLE, INC.

One Holland, Irvine, California 92618, U.S.A. Phone: +1-949-951-5003

SHIMANO EUROPE B.V.

High Tech Campus 92, 5656 AG Eindhoven, The Netherlands Phone: +31-402-612222

SHIMANO INC.

3-77 Oimatsu-cho, Sakai-ku, Sakai-shi, Osaka 590-8577, Japan

Please note: specifications are subject to change for improvement without notice. (English)
© Mar. 2018 by Shimano Inc. ITP