

Dealer's Manual

ROAD	MTB	Trekking
City Touring/ Comfort Bike	URBAN SPORT	E-BIKE

SHIMANO STEPS

E6000 Series

SC-E6000
SC-E6010
SC-S705
SW-E6000
SW-E6010
SW-S705
FC-E6000
FC-E6010
SM-CRE60
DU-E6000
DU-E6001
DU-E6010
DU-E6050
DU-E6002
DU-E6012
SM-DUE01
SM-DUE10
SM-DUE11
BT-E6000
BT-E6001
BT-E6010
BT-E8010
BT-E8020

BM-E6000
BM-E6010
SM-BME60
SM-BME61
BM-E8010
BM-E8020
SM-BCE60
EC-E6000
TL-FC38
TL-DUE60
RT-EM300
RT-EM600
RT-EM800
RT-EM810
RT-EM900
RT-EM910

CONTENTS

IMPORTANT NOTICE	iv
TO ENSURE SAFETY	v

Chapter1 INSTALLATION 1-1

INSTALLATION.....	1-2
Names of parts.....	1-4
Product specifications.....	1-5
Installing the cycle computer.....	1-6
Installing and removing the cycle computer	1-7
Adjusting the angle of the cycle computer	1-7
Using the cable band to attach the assist switch to the handlebar	1-8
Installing the assist switch.....	1-8
Installing the battery mount	1-10
Installing the battery.....	1-25
Removing the battery	1-27
Installing the speed sensor	1-30
Mounting the magnet	1-31

Chapter2 INSTALLING AND WIRING THE DRIVE UNIT 2-1

INSTALLING AND WIRING THE DRIVE UNIT	2-2
Installing the drive unit.....	2-2
Drive unit wiring diagram	2-3
Connecting the power cord.....	2-4
Installing the ferrite core (DU-E6001/E6010/E6050)	2-5
Connecting the electric wire.....	2-6
Connecting the assist switch and drive unit to the cycle computer.....	2-6
Connecting the speed sensor to the drive unit	2-7
Connecting the light to the drive unit.....	2-7
Installing the ferrite core (MU-S705).....	2-10
Installing the crank and front chainring.....	2-11
Measuring and adjusting the chain tension.....	2-13

Chapter3 CHARGING THE BATTERY

3-1

CHARGING THE BATTERY	3-2
Introduction.....	3-2
Proper use of the battery.....	3-2
Charging procedures.....	3-2
About the charger LED lamp	3-6
About the battery LED lamps	3-6
Turning the power ON / OFF.....	3-8

Chapter4 CYCLE COMPUTER DISPLAY AND SETTING

4-1

CYCLE COMPUTER DISPLAY AND SETTING	4-2
Names and functions of the parts of the assist switch.....	4-2
Basic screen display of the cycle computer	4-3
Changing the settings.....	4-14
Error messages on the cycle computer.....	4-36

Chapter5 CONNECTION AND COMMUNICATION WITH PC

5-1

CONNECTION AND COMMUNICATION WITH PC	5-2
Drive unit setting backup function for the cycle computer	5-2
Settings customizable in E-TUBE PROJECT.....	5-3
Connecting to the PC	5-4

Chapter6 MAINTENANCE

6-1

MAINTENANCE	6-2
Replacing the front chainring	6-2

IMPORTANT NOTICE

- **This dealer's manual is intended primarily for use by professional bicycle mechanics.**

Users who are not professionally trained for bicycle assembly should not attempt to install the components themselves using the dealer's manuals. If any part of the information on the manual is unclear to you, do not proceed with the installation. Instead, contact your place of purchase or a bicycle dealer for their assistance.

- Make sure to read all instruction manuals included with the product.
- Do not disassemble or modify the product other than as stated in the information contained in this dealer's manual.
- All dealer's manuals and instruction manuals can be viewed on-line on our website (<http://si.shimano.com>).
- For consumers who do not have easy access to the internet, please contact a SHIMANO distributor or any of the SHIMANO offices to obtain a hardcopy of the User's Manual.
- Please observe the appropriate rules and regulations of the country, state or region in which you conduct your business as a dealer.

For safety, be sure to read this dealer's manual thoroughly before use, and follow it for correct use.

The following instructions must be observed at all times in order to prevent personal injury and physical damage to equipment and surroundings. The instructions are classified according to the degree of danger or damage which may occur if the product is used incorrectly.

 **DANGER**

Failure to follow the instructions will result in death or serious injury.

 **WARNING**

Failure to follow the instructions could result in death or serious injury.

 **CAUTION**

Failure to follow the instructions could cause personal injury or physical damage to equipment and surroundings.

TO ENSURE SAFETY

DANGER

Be sure to also inform users of the following:

■ Handling the battery

- Do not deform, modify, disassemble or apply solder directly to the battery. Doing so may cause leakage, overheating, bursting, or ignition of the battery.
- Do not leave the battery near sources of heat such as heaters. Do not heat the battery or throw it into a fire. Doing so may cause bursting or ignition of the battery.
- Do not subject the battery to strong shocks or throw it. If this is not observed, overheating, bursting, or fire may occur.
- Do not place the battery into fresh water or sea water, and do not allow the battery terminals to get wet. Doing so may cause overheating, bursting, or ignition of the battery.
- Use the SHIMANO specified charger and observe the specified charging conditions when charging the specified battery. Not doing so may cause overheating, bursting, or ignition of the battery.

WARNING

• Be sure to follow the instructions provided in the manuals when installing the product.

It is recommended that you use only genuine SHIMANO parts. If parts such as bolts and nuts become loose or damaged, the bicycle may suddenly fall over, which may cause serious injury.

In addition, if adjustments are not carried out correctly, problems may occur, and the bicycle may suddenly fall over, which may cause serious injury.

-  Be sure to wear safety glasses or goggles to protect your eyes while performing maintenance tasks such as replacing parts.
- For information on products not explained in this manual, refer to the manuals provided with each product.
- After reading the dealer's manual thoroughly, keep it in a safe place for later reference.

Be sure to also inform users of the following:

- Be careful not to let yourself be distracted by the cycle computer display while riding the bicycle. Otherwise, you may fall off the bicycle.
- Before riding, check that the wheels are secured. Otherwise, you may fall off the bicycle and be seriously injured.
- Be sufficiently familiar with how to start the power assisted bicycle before riding on busy streets. Otherwise, you may start the bicycle abruptly and have an accident.
- Make sure that the light is on during night riding.
- Do not disassemble the product. Disassembling it may cause injury to persons.
- When charging the battery while it is installed on the bicycle, do not move the bicycle. The battery charger's power plug may not be completely inserted into the outlet, which may lead to fire.
- Do not inadvertently touch the drive unit when it has been continuously used for a long period of time. The surface of the drive unit becomes hot and could cause burns.

■ Lithium Ion Battery

- If any liquid leaking from the battery gets into your eyes, immediately wash the affected area thoroughly with clean water such as tap water without rubbing your eyes, and seek medical advice immediately. If this is not done, the battery liquid may damage your eyes.
- Do not recharge the battery in very humid places or the outdoors. If this is not observed, electric shocks may result.
- Do not insert or remove the plug while it is wet. If this is not observed, electric shocks may result. If there is water leaking out of the plug, dry it thoroughly before inserting it.
- If the battery does not become fully charged after 2 hours of charging, immediately unplug the battery from the outlet and contact the place of purchase. Doing otherwise may cause overheating, bursting, or ignition of the battery.
- Do not use the battery if it has any noticeable scratches or other external damage. Doing so may cause bursting, overheating or problems with operation.
- The operating temperature ranges for the battery are given below. Do not use the battery in temperatures outside these ranges. If the battery is used or stored in temperatures outside these ranges, fire, injury or problems with operation may occur.
 1. During discharge: -10 °C - 50 °C
 2. During charging: 0 °C - 40 °C

■ Items related to installation to and maintenance of the bicycle

- Be sure to remove the battery and charger before wiring or attaching parts to the bicycle. Otherwise, an electric shock may result.
- Maintenance interval depends on the usage and riding circumstances. Clean the chain with an appropriate chain cleaner regularly. Never use alkali based or acid based solvents such as rust cleaners. If these solvents are used, the chain may break and cause serious injury.

**Be sure to also inform users of the following:**

- Observe the instructions in the user's manual for the bicycle, in order to ride safely.
- Periodically check the battery charger and adapter, particularly the cord, plug, and case, for any damage. If the charger or adapter is broken, do not use it until it has been repaired.
- Use the product under the direction of a safety supervisor or the directions for use. Do not allow physically, sensory, or mentally impaired persons, inexperienced persons, or persons with no required knowledge including children to use this instrument.
- Do not allow children to play near the product.
- If any malfunction or trouble occurs, consult the place of purchase.
- Never modify the system. This may cause a malfunction in the system.

■ Lithium Ion Battery

- Do not leave the battery in a place exposed to direct sunlight, inside a vehicle on a hot day, or other hot places. This may result in battery leakage.
- If any leaked fluid gets on your skin or clothes, wash it off immediately with clean water. Otherwise, the leaked fluid may damage your skin.
- Store the battery in a safe place out of the reach of infants and pets.

NOTE

Be sure to also inform users of the following:

- Be sure to attach dummy plugs to any unused ports.
- For installation and adjustment of the product, consult a dealer.
- The units are designed to be fully waterproof to withstand wet weather riding conditions. However, do not deliberately place them into water.
- Do not clean the bicycle with a high-pressure washer. If water gets into any of the components, operating problems or rusting may result.
- Handle the components carefully, and avoid subjecting them to any strong shocks.
- Do not place the bicycle upside down. Doing so may damage the cycle computer or shift switch.
- Although the bicycle still functions as a normal bicycle even when the battery is removed, the light does not turn on if it is connected to the electric power system. Be aware that using the bicycle under these conditions will be considered non-observance of the road traffic laws in Germany.
- When carrying the bicycle in a car, remove the battery from the bicycle and place it on a stable surface in the car.
- Before connecting the battery, make sure that there is no water collecting in the connector where the battery will be connected.
- When charging the battery while it is mounted on the bicycle, be careful of the following:
 - When charging, make sure there is no water on the charging port or the charger plug.
 - Check that the battery mount is locked before charging.
 - Do not remove the battery from the battery mount while charging.
 - Do not ride the bicycle with the battery charger mounted on.
 - Close the charging port cap when not charging.
 - Stabilize the bicycle to ensure that it does not collapse during charging.
- The use of a genuine SHIMANO battery is recommended. If using a battery from another manufacturer, make sure to carefully read the instruction manual for the battery before use.
- It may not be possible to turn the power on from the cycle computer (SC-E6010) when the cycle computer is used or left for long periods of time at low temperatures. Press the battery's power button to turn the power on. If the power still does not turn on, contact the place of purchase.
- Some of the important information in this dealer's manual can also be found on the device labels.
- The number found on the battery key is necessary when purchasing spare keys. Store it carefully.
- Use a damp cloth with the water well wrung out, when cleaning the battery and plastic cover.
- If you have any questions about the use and maintenance of the product, consult the dealer where you made the purchase.
- Contact the place of purchase for updates to the component software. The most up-to-date information is available on the SHIMANO website. For details, refer to the "Connection and communication with the PC" section.
- Products are not guaranteed against natural wear and deterioration from normal use and aging.
- For maximum performance we highly recommend SHIMANO lubricants and maintenance products.

■ Lithium Ion Battery**Disposal information for countries outside the European Union**

This symbol is only valid within the European Union.

Follow local regulations when disposing of used batteries. If you are not sure, consult the place of purchase or a bicycle dealer.

■ Items related to installation to and maintenance of the bicycle

- Do not use thinner or other solvents to clean any of the components. Such substances may damage the surfaces.
- You should periodically wash the chainrings in a neutral detergent. In addition, cleaning the chain with neutral detergent and lubricating it can be an effective way of extending the useful life of the chainrings and the chain.
- The proper assistance cannot be achieved unless the proper settings have been made (installation of the crank in the proper position, proper adjustment of the chain tension, etc.). Be particularly careful with these settings for the DU-E6010/DU-E6012 which is compatible with coaster brakes.

















The actual product may differ from illustrations, as this manual is intended chiefly to explain the procedures for using the product.











Chapter1 INSTALLATION

INSTALLATION

List of tools to be used

The following tools are required to assemble the product.

Component	Where to use	Tool	
Cycle computers	Handlebar fixing bolt		Screwdriver [#2]
	Angle adjustment screw		Screwdriver [#2]
Assist switch (SW-E6000)	Fixing bolt		Screwdriver [#2]
Assist switch (SW-E6010)	Fixing bolt		3 mm hexagon wrench
Battery Mount (SM-BME61)	Key unit Mount lower case		3 mm hexagon wrench
	Key unit cover Mount upper case		Screwdriver [#1]
Battery mount (BM-E8010)	Mount lower case	 	3 mm hexagon wrench / 8 mm spanner
	Key unit		3 mm hexagon wrench
	Key unit cover		2.5 mm hexagon wrench
	Mount upper case		2.5 mm hexagon wrench
Battery mount (BM-E8020)	Mount lower case		5 mm hexagon wrench
	Mount upper case		Screwdriver [#2]
	Key cylinder		2 mm hexagon wrench
	Key unit		5 mm hexagon wrench
	Key unit cover		Screwdriver [#2]

Component	Where to use	Tool	
Speed sensor (SM-DUE10)	Speed sensor fixing bolt		4 mm hexagon wrench
Speed sensor (SM-DUE11)	Speed sensor fixing bolt		Hexalobular [#10]
Magnet unit	Mounting screw		Screwdriver [#2]
Electric wire	Connector		TL-EW02
Light adapter	Unit fixing screw		Screwdriver [#2]
Drive Unit	Frame installation bolt		M8 bolt and nut-compatible*
	Cover fixing bolt (M3)		Screwdriver [#2]
Front chainring	Lock ring	  	TL-FC32 / 36+TL-FC38
Crank arm	Crank installation bolt		14 mm socket wrench
Chain	Chain		TL-DUE60

* For information on compatible tools, contact a manufacturer of completed bicycles.

■ Names of parts

In the case of mechanical gear shifting system

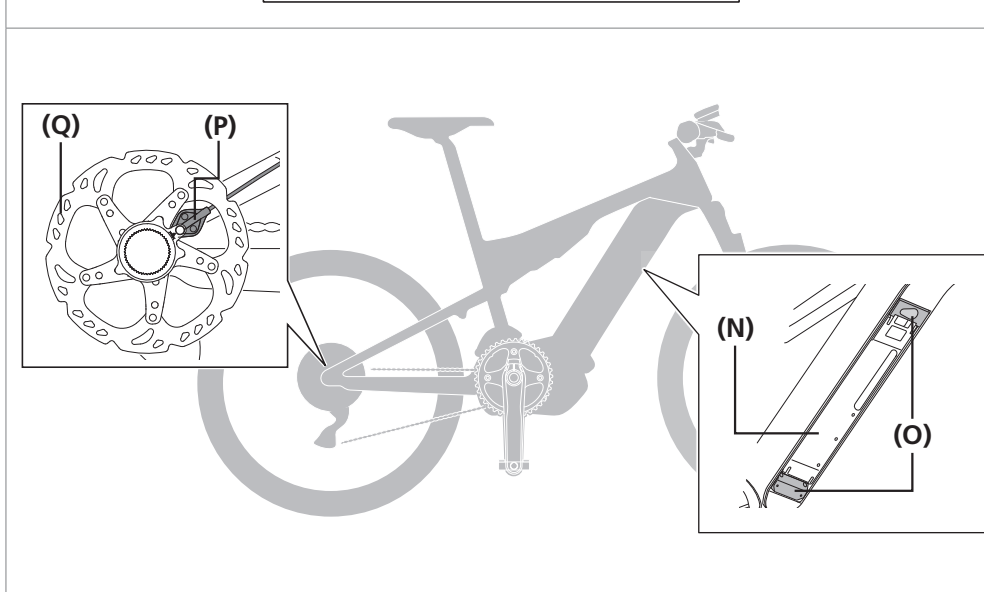
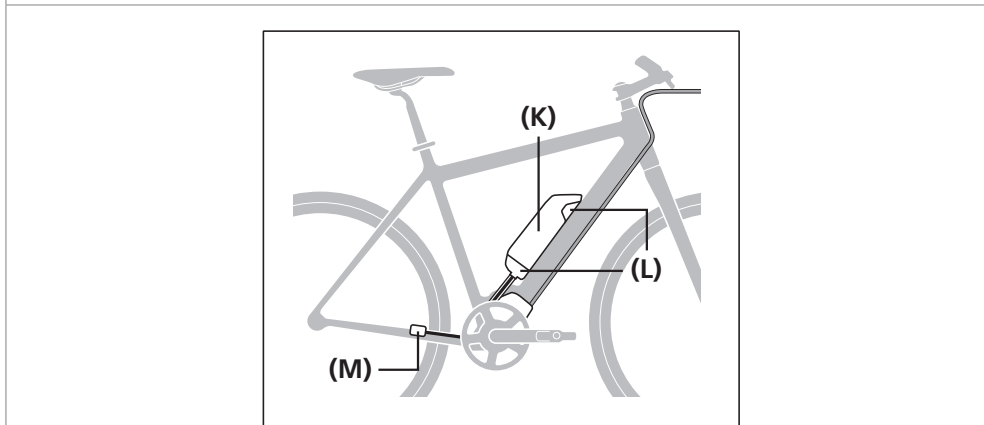
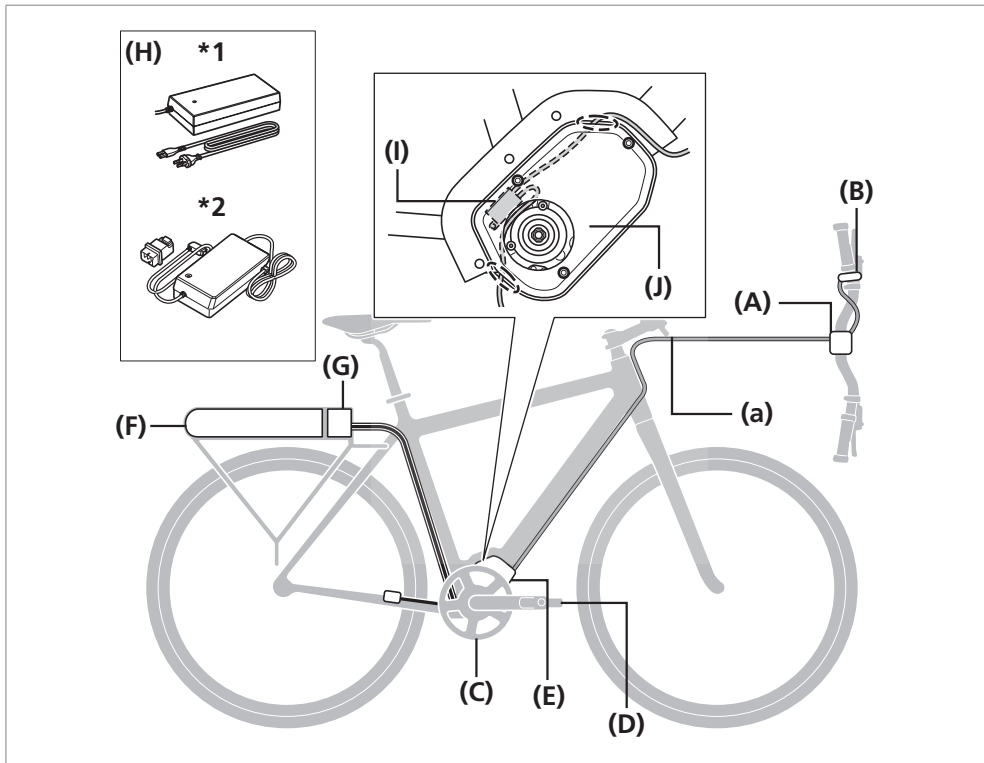

(A) Cycle computer	SC-E6000/ SC-E6010
(B) Assist switch	SW-E6000 SW-E6010
(C) Front chainring	SM-CRE60
(D) Crank arm	FC-E6000 FC-E6010
(E) Drive unit/ Speed sensor	DU-E6000 DU-E6001 DU-E6010 DU-E6050 DU-E6002 DU-E6012
(F) Battery (external type)	BT-E6000 BT-E6001*3
(G) Battery Mount (external type)	SM-BME60 BM-E6000
(H) Battery charger	*1: SM-BCE60 +SM-BCC1 *2: EC-E6000
(I) Light adapter	SM-DUE01
(J) Drive unit cover	SM-DUE60
(K) Battery (external type)	BT-E6010 BT-E8010*3
(L) Battery Mount (external type)	SM-BME61 BM-E6010 BM-E8010
(M) Speed sensor	SM-DUE10
(N) Battery (built-in type)	BT-E8020*3
(O) Battery mount (built-in type)	BM-E8020
(P) Speed sensor	SM-DUE11
(Q) Disc brake rotor	RT-EM300 RT-EM600 RT-EM800 RT-EM810 RT-EM900 RT-EM910

* 3 If the firmware version of the drive unit is 3.2.6 or lower, the battery may not operate properly. Update the firmware version via E-TUBE PROJECT.

— Wire harness

— E-TUBE

TECH TIPS

- The drive specification may be of the belt type. In this case, the front chainring, rear sprocket and belt are supplied by the belt's manufacturer. Also, for details concerning assembly and adjustment, refer to the technical information provided by the belt manufacturer.
- Maximum cable length (EW-SD50)
(a) ≤ 1600 mm

In the case of electronic internal geared hub system

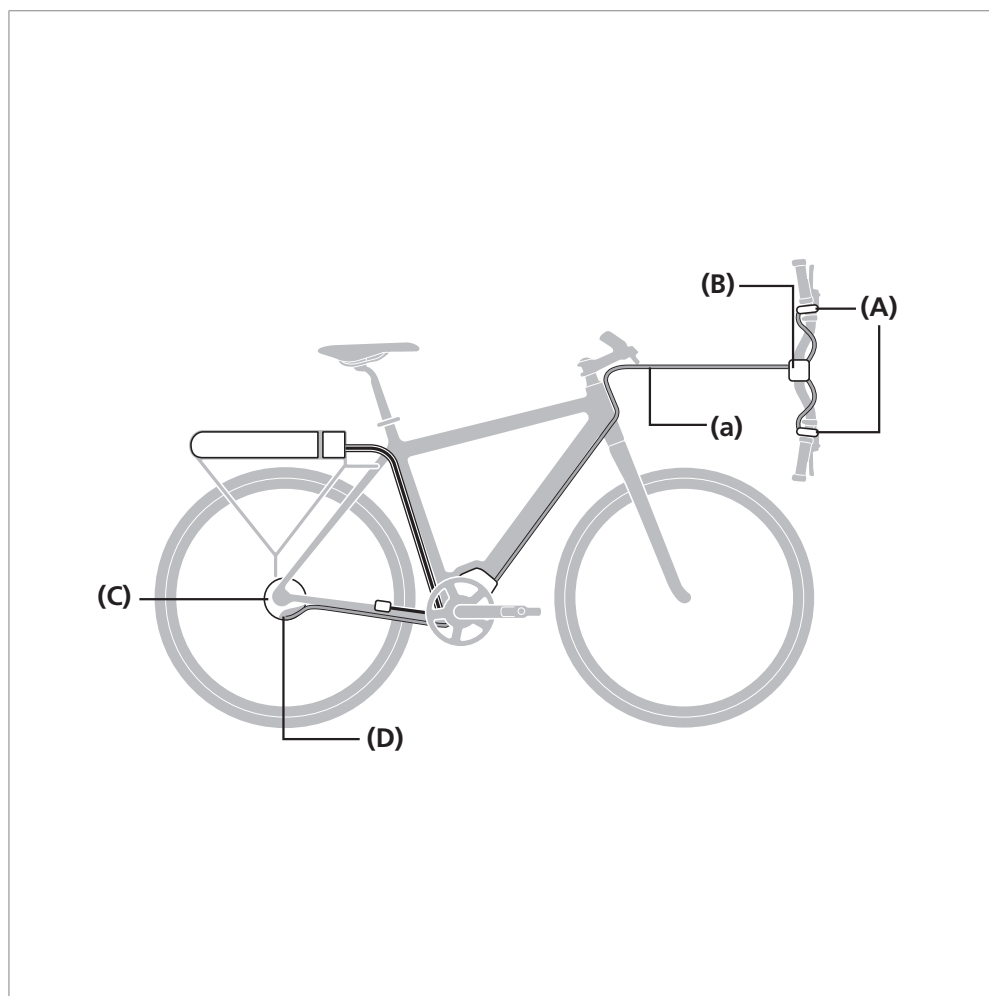

(A) Assist/Shift switch	SW-E6000 SW-E6010 SW-S705
(B) Cycle computer	SC-E6000 SC-E6010
(C) Motor unit	MU-S705
(D) Internal geared hub	SG-C6060 SG-S705 SG-S505

— Wire harness

— E-TUBE



TECH TIPS

- The drive specification may be of the belt type. In this case, the front chainring, rear sprocket and belt are supplied by the belt's manufacturer. Also, for details concerning assembly and adjustment, refer to the technical information provided by the belt manufacturer.
- For information on how to install MU-S705, refer to "Installation of the motor unit to the hub (MU-S705)" in the dealer's manual for the ALFINE S705 series.
- **Maximum cable length (EW-SD50)**
(a) ≤ 1600 mm

Product specifications

Operating temperature range: During discharge	-10 – 50 °C	Battery type	Lithium Ion Battery
Operating temperature range: During charging	0 – 40 °C	Nominal capacity	Refer to the user's manual for the battery "UM-70F0A". For the latest information on manuals, see the website (http://si.shimano.com).
Storage temperature	-20 – 70 °C	Rated voltage	36 V DC
Storage temperature (Battery)	-20 – 60 °C	Drive unit type	Midship
Charging voltage	100 – 240 V AC	Motor type	Brush-less DC
Charging time	Refer to the user's manual for the battery "UM-70F0A". For the latest information on manuals, see the website (http://si.shimano.com).	Rated drive unit power	250 W

* The range of the assist function speed is different depending on the specifications.

DU-E6000/E6001/E6010: 25 km/h or less

DU-E6050: 20 mile/h or less

■ Installing the cycle computer

1 Open the clamp (B) and attach it to the handlebar.

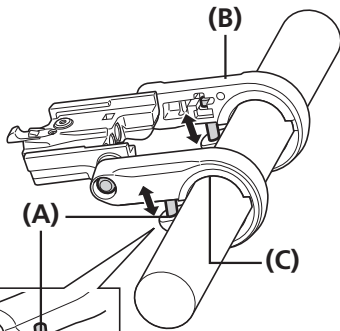

Attach the handlebar fixing bolt (A) and tighten to the specified tightening torque using a screwdriver.

2

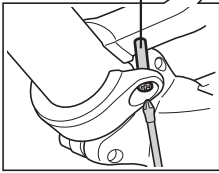

- (A) Handlebar fixing bolt
- (B) Clamp
- (C) Adapter

Handlebar compatibility table

øA	øB-øA	Adapter	Fixing bolt
ø23.4-ø24	0-1.1	X	15.5 mm
ø24-ø25.5	0-1.1	X	20 mm
ø31.3-ø31.9	0-0.6	-	20 mm

* X: OK

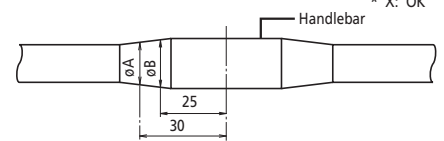

Tightening torque



1 N·m



TECH TIPS

When removing the cycle computer, reverse the procedure.

■ Installing and removing the cycle computer

1

Slide the cycle computer (A) into the bracket (B) as shown in the illustration. Insert it firmly until you hear it click.

- (A) Cycle computer
- (B) Bracket

2

To remove the cycle computer, slide it while pushing the bracket lever (C).

- (C) Lever

NOTE

- If the cycle computer is not in the correct place, the assist function will not operate normally.
- The dimensions of (C) differ for SC-E6000 and SC-E6010.

■ Adjusting the angle of the cycle computer

Loosen the angle adjustment screw (A) with a screwdriver. Adjust the angle of the cycle computer to make it easier to see while riding. After determining the angle, tighten the screw to the designated torque.

- (A) Angle adjustment screw

Tightening torque	
	0.5 N·m

▶▶ Using the cable band to attach the assist switch to the handlebar

■ Using the cable band to attach the assist switch to the handlebar

1

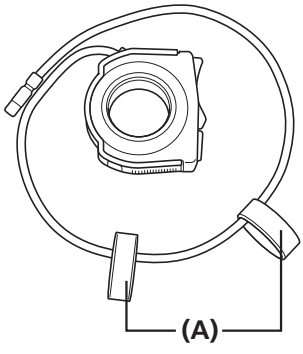

Temporarily attach the cable band (A) to the assist switch. Adjust the cable band according to the length of the handlebar.

2

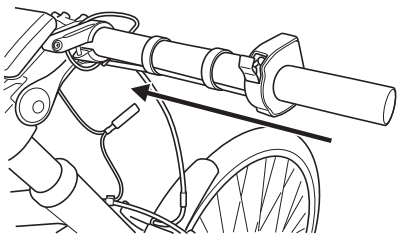

Attach the assist switch mounted with the cable band to the handlebar.

(A) Cable band



TECH TIPS

The cable band is included in SW-E6000.

■ Installing the assist switch

1

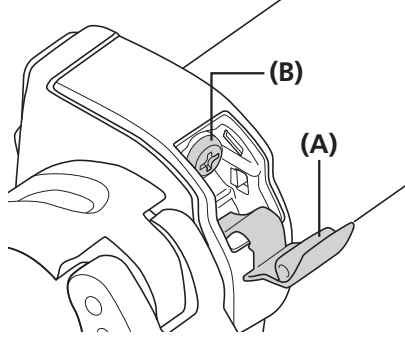

Attach the assist switch to a $\varnothing 22.2$ handlebar with the electric wire routed under the switch and open the fixing bolt cover (A).

(A) Fixing bolt cover

(B) Fixing bolt

2

<SW-E6000>

+
#2

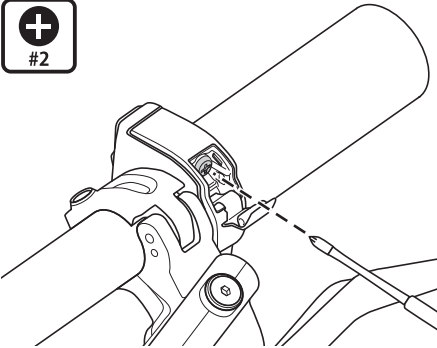

Tighten the fixing bolt (B) to the specified tightening torque using a screwdriver.
For SW-E6010, tighten the bolt using a 3 mm hexagon wrench.

Tightening torque

SW-E6000



SW-E6010



1.5 N·m



TECH TIPS

When removing the cycle computer, reverse the procedure.

Example of routing the electric wire

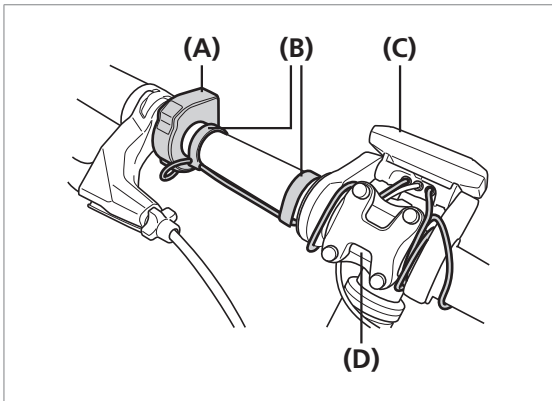

Example 1: Secure the electric wire of the assist switch (A) to the handlebar using the cable band (B). Wind the excess electric wire around the area between the cycle computer (C) and stem (D), then connect the wire to the cycle computer.

- (A) Assist switch
- (B) Cable band
- (C) Cycle computer
- (D) Stem

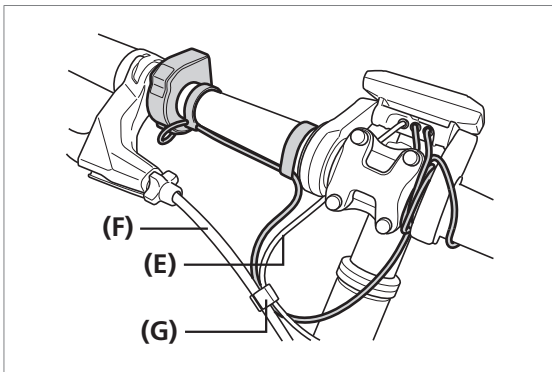

Example 2: Secure the electric wire of the assist switch to the handlebar using the cable band. Bind the electric wire of the assist switch and that of the cycle computer (E) to the brake outer casing (F) using the band (G) and connect the electric wire of the assist switch to the cycle computer.

- (E) Electric wire of the cycle computer
- (F) Brake outer casing
- (G) Band



TECH TIPS

The band is included in SC-E6000.

■ Installing the battery mount

SM-BME60 / BM-E6000

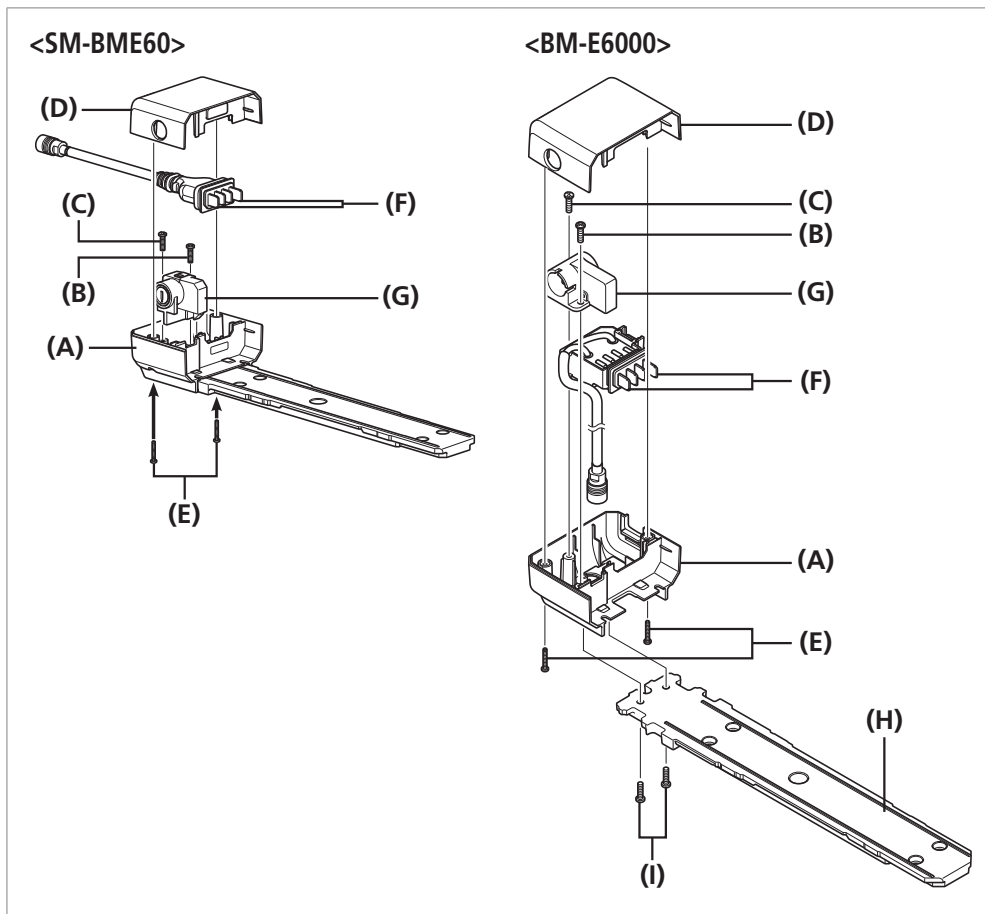

- (A) Mount lower case
- (B) M4 bolt
- (C) M4 bolt (one-way type)
- (D) Mount upper case
- (E) Hexalobular #10H
- (F) Plug
- (G) Key unit (not included with the product)
- (H) Battery mount rail
- (I) M4 bolt

<For SM-BME60>

1 Secure the key unit (G) to the mount lower case (A) by tightening M4 bolt (B) and (C).

2 Align the plug (F) with the mount lower case (A).

3 Assemble the mount upper case (D) with the mount lower case (A) by 2 bolts (E).



Tightening torque	
	(B) 1.6 - 1.8 N·m
	(C) 1.6 - 1.8 N·m

Tightening torque	
	1 - 1.3 N·m

<For BM-E6000>

1

Secure the key unit (G) to the mount lower case (A) by tightening M4 bolt (B) and (C).

Tightening torque	
	(B) 1.6 - 1.8 N·m
	(C) 1.6 - 1.8 N·m

2

Align the plug (F) and battery mount rail (H), in that order, with the mount lower case (A).

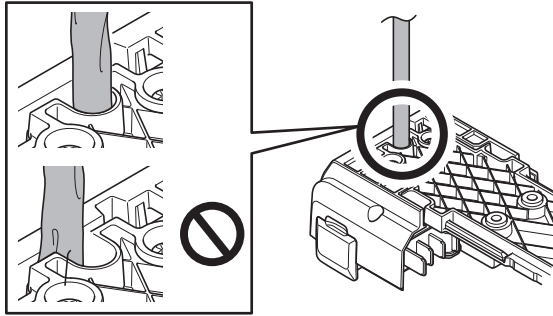

3

Mount the mount lower case (A) and the battery mount rail (H) using the M4 bolt (I).

Tightening torque	
	1.6 - 1.8 N·m

4

Assemble the mount upper case (D) with the mount lower case (A) by 2 bolts (E).

Tightening torque	
	1.1 - 1.3 N·m

▶▶ Installing the battery mount

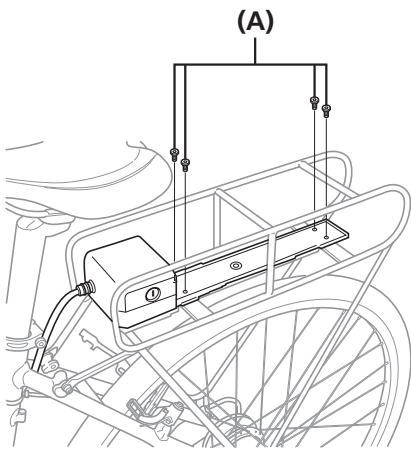

Align the mounting holes in the carrier with those in the battery mount. Insert hexagon socket head cap screws **(A)** into the upper part of the battery mount and tighten it to the carrier.

(A) Hexagon socket head cap screw (M5) (not included with the product)

NOTE

Make sure that the charging port cap is closed securely.

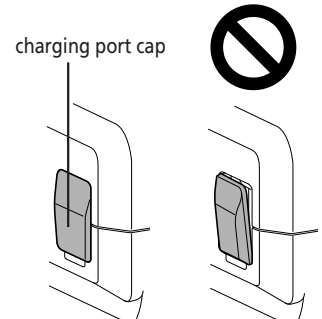

TECH TIPS

Bolts and nuts are not included with SHIMANO products. Use those supplied by the manufacturer.

For information on the tightening torques, contact the manufacturer of the carrier.

SM-BME61 / BM-E6010

1

Attach the mount lower case (E) to the mounting holes in the frame, insert the mount fixing bolts (C) into the washers (D), and secure the case using the bolts. Then, temporarily attach the key unit (B) with the key unit fixing bolts (A).

- (A) Key unit fixing bolt (M5)
- (B) Key unit (not included with the product)
- (C) Mount fixing bolt (M5)
- (D) Washers
- (E) Mount lower case

Tightening torque	
	(C) 3 N·m

NOTE

Key unit is not included with SHIMANO products.

2

Adjust the position of the key unit to allow a clearance of 223 mm between (a) and (b) shown in the illustration. Temporarily attach the key unit cover and perform adjustment to make sure that the battery can be smoothly connected and disconnected and no noise will be produced due to looseness during traveling. Then, fully tighten the key unit fixing bolts (A).

Tightening torque	
	3 N·m

3

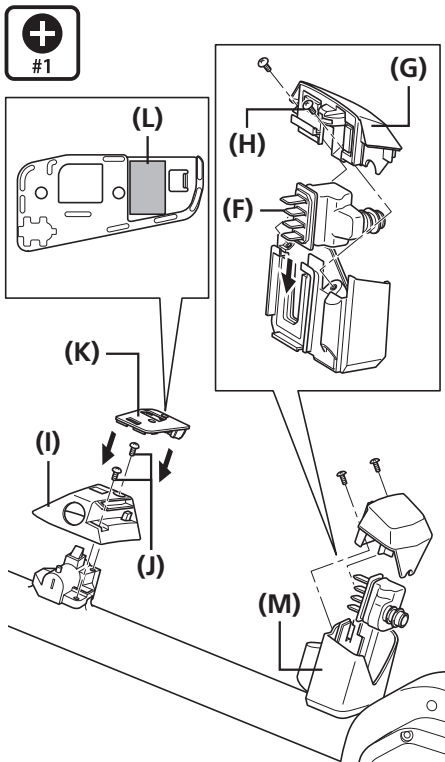

<SM-BME61>
Fully tighten the key unit cover fixing bolts (J) to attach the key unit cover (I).

Mount the battery rattle prevention spacer (K). When mounting the battery rattle prevention spacer (K), peel the release liner from the double-sided seal (L) on the back of the battery rattle prevention spacer and mount.

Insert the plug (F) into the mount lower case (M). Insert the plug (F) between the mount upper case (G), and secure them using the mount upper case fixing bolts (H).

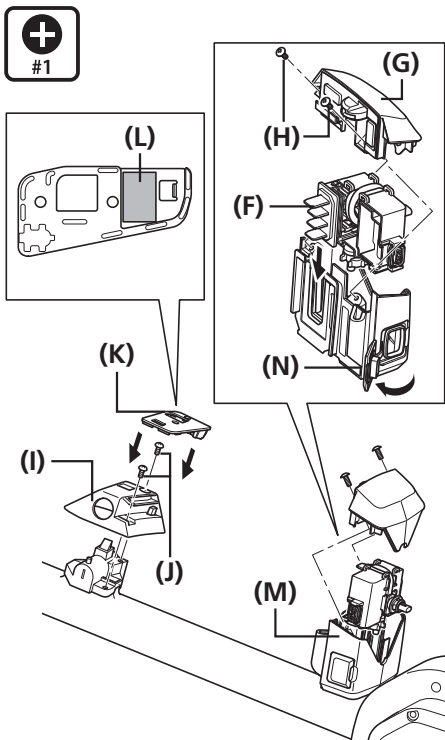

<BM-E6010>
Fully tighten the key unit cover fixing bolts (J) to attach the key unit cover (I).

Mount the battery rattle prevention spacer (K). When mounting the battery rattle prevention spacer (K), peel the release liner from the double-sided seal (L) on the back of the battery rattle prevention spacer and mount.

Fully open the charging port cap (N), and insert the plug (F) into the mount lower case (M). Fit the plug (F) between the two parts of the mount upper case (G), and secure it using the mount upper case fixing bolts (H).

- (F) Plug
- (G) Mount upper case
- (H) Mount upper case fixing bolt (M3)
- (I) Key unit cover
- (J) Key unit cover fixing bolt (M4)
- (K) Battery rattle prevention spacer
- (L) Double-sided seal
- (M) Mount lower case
- (N) Charging port cap

Tightening torque



(H), (J) 0.6 N·m

NOTE

- Check that there is no oil, foreign objects, etc., on the adhesive surface of the double-sided seal (L) or on the surface to which the double-sided seal (L) is to be attached. If there is, remove it.
- For BM-E6010, make sure to pull open the charging port cap (N) fully before inserting the plug (F), as in the illustration. Inserting the plug with the cap closed will disrupt the proper opening/closing of the cap.

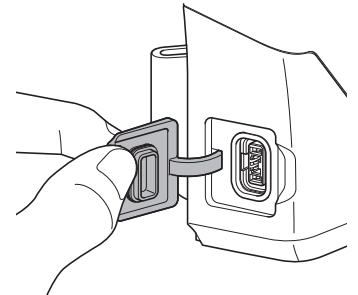

- Make sure that the charging port cap is closed securely.

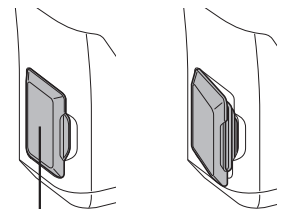

charging port cap

BM-E8010

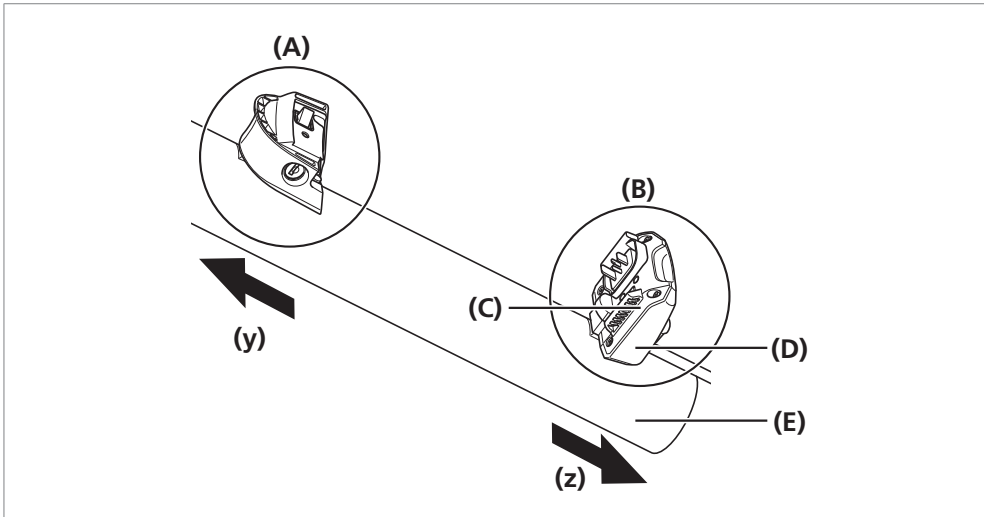

(y) Front of bicycle

(z) Rear of bicycle

(A) Key unit

(B) Battery connection unit

(C) Mount upper case

(D) Mount lower case

(E) Frame

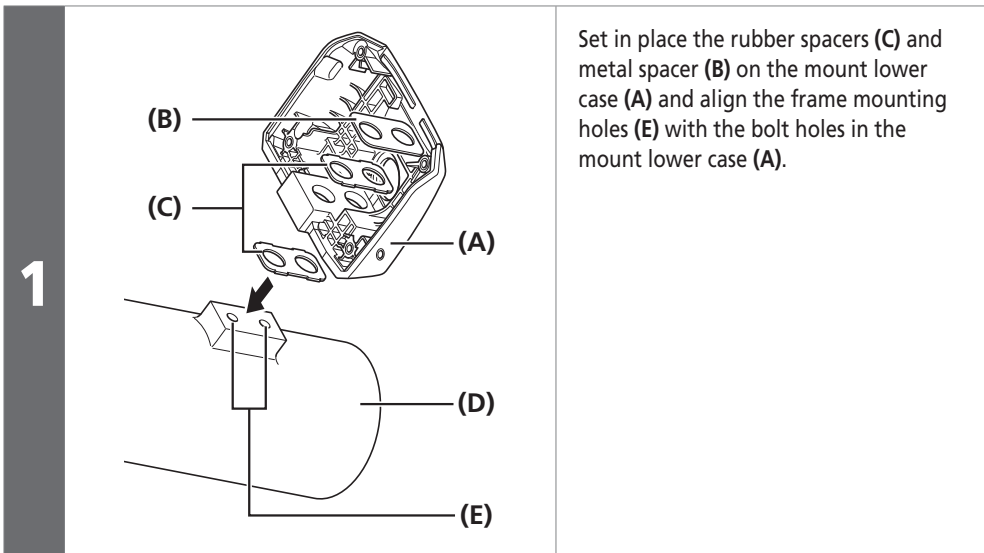

(A) Mount lower case

(B) Metal spacer

(C) Rubber spacer

(D) Frame

(E) Frame mounting hole

1

▶▶ Installing the battery mount

2

Secure the mount lower case (H) by tightening the two types of mount fixing bolt (M5) (F)/(G).
Tighten the mount fixing bolt (M5) (low head type) (G) first.

- (F)** Mount fixing bolt (M5) (hexagon bolt type):
Use a 3 mm hexagon wrench or 8 mm spanner on the mount fixing bolt.
- (G)** Mount fixing bolt (M5) (low head type):
Use a 3 mm hexagon wrench on the mount fixing bolt.
- (H)** Mount lower case

Tightening torque	
	(F), (G) 3 N·m
	(F) 3 N·m

3

Temporarily attach the key unit with the key unit fixing bolts (M5) (J).

- (I)** Key unit:
Key unit is not included with SHIMANO products.
- (J)** Key unit fixing bolt (M5)
- (K)** Washer

4

Adjust the position of the key unit so that the distance between section (a) of the key unit and section (b) of the mount lower case is 224.4 mm and then fully tighten the key unit fixing bolts (M5) (J).

Tightening torque	
	3 N·m

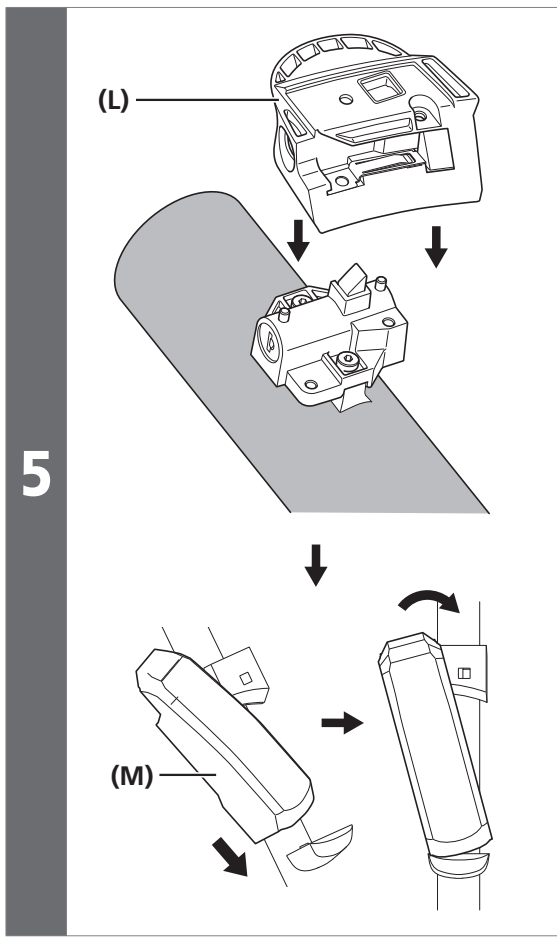

Temporarily attach the key unit cover (L) to the key unit and adjust so that the battery (M) can be smoothly connected/disconnected and no noise is produced due to looseness during riding.

- (L) Key unit cover
- (M) Battery

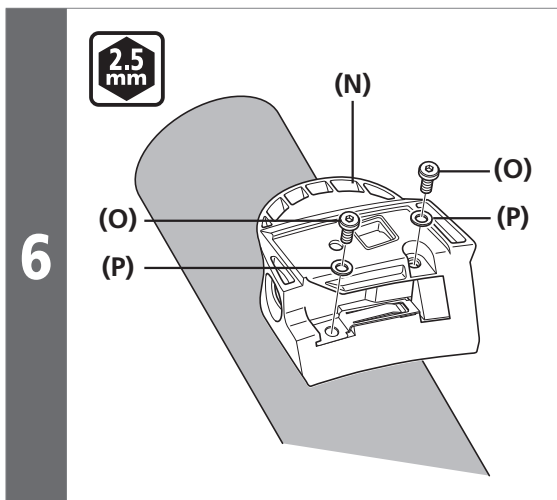

Secure the key unit cover with the key unit cover fixing bolts (M4) (O).

- (N) Key unit cover
- (O) Key unit cover fixing bolt (M4)
- (P) Washer

Tightening torque	
	0.6 N·m

7

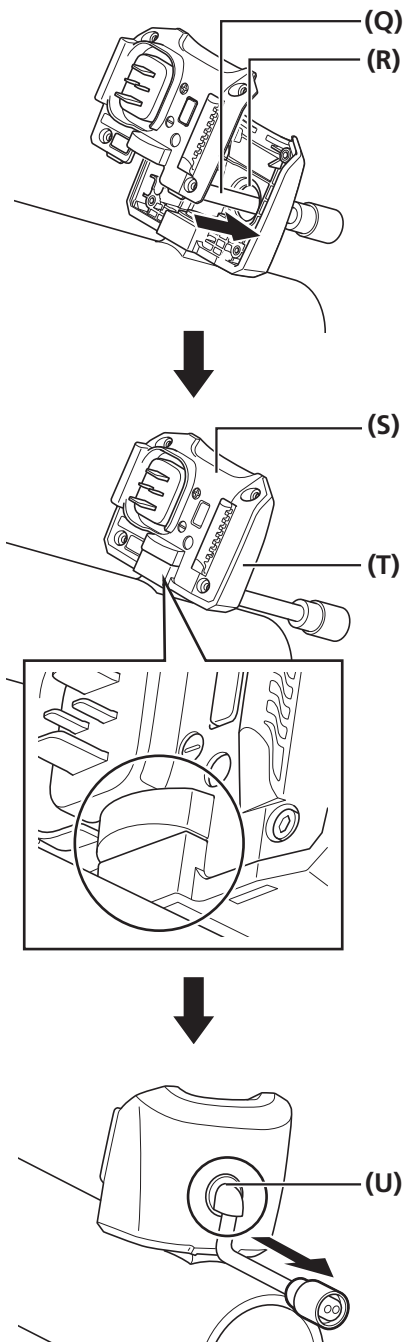

Route the power cord (Q) through the cable routing hole (R).

Align the protruding parts of the mount upper case (S) and mount lower case (T).

Pull the power cord (Q) until the rubber bush (U) is implanted in the cable routing hole (R).

- (Q) Power cord
- (R) Cable routing hole
- (S) Mount upper case
- (T) Mount lower case
- (U) Rubber bush

8

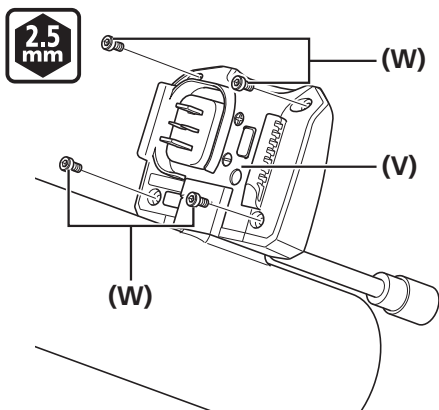

Tighten on the mount upper case (V) using the mount upper case fixing bolts (M3) (W).

- (V) Mount upper case
- (W) Mount upper case fixing bolt (M3)

Tightening torque	
	0.6 N·m

BM-E8020

Assembly of the battery connection unit

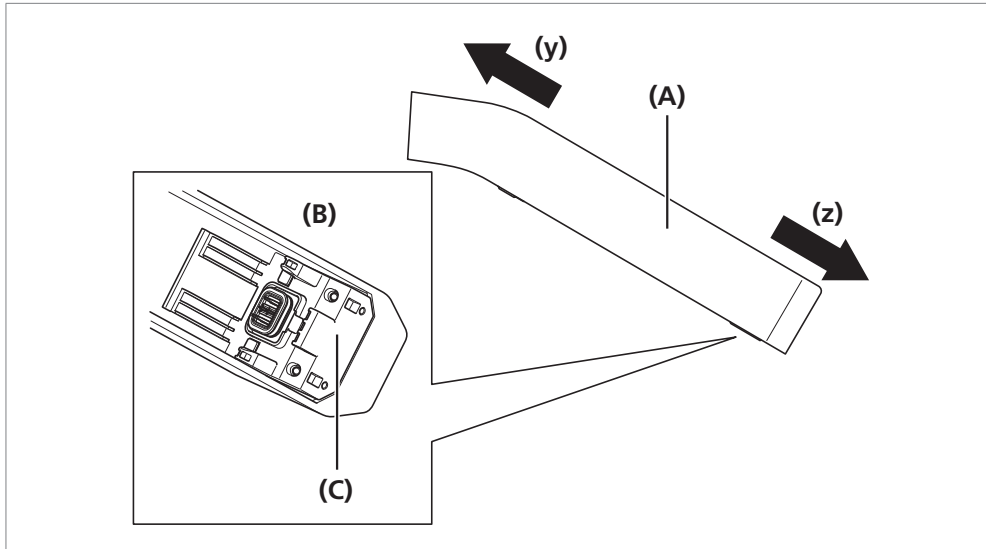

(y) Front of bicycle

(z) Rear of bicycle

(A) Frame

(B) Battery connection unit

(C) Mount upper case and mount lower case when assembled

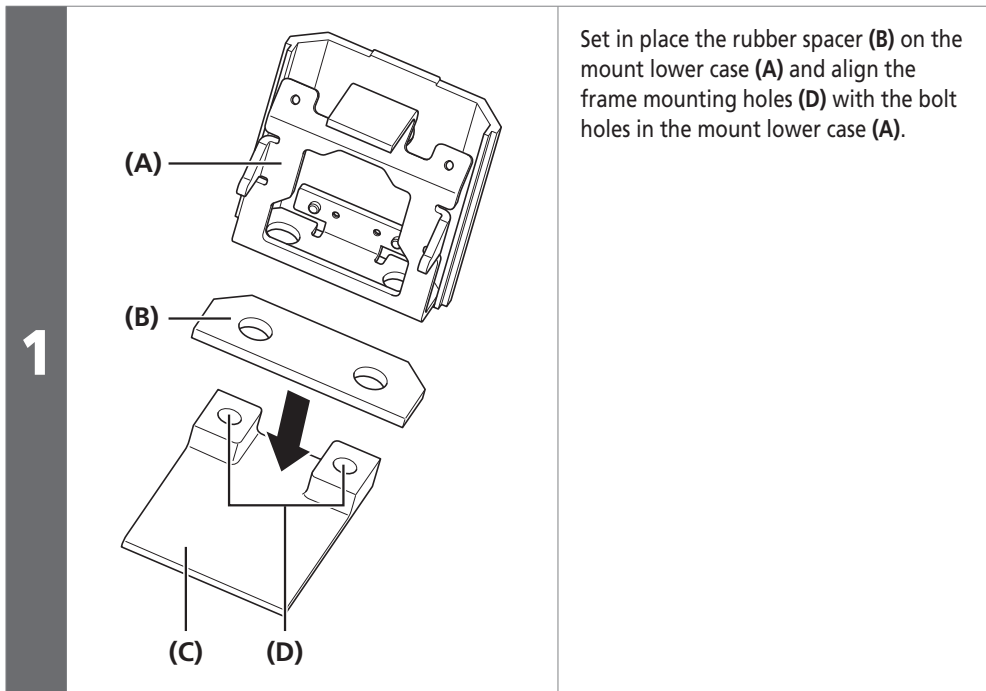

Set in place the rubber spacer (B) on the mount lower case (A) and align the frame mounting holes (D) with the bolt holes in the mount lower case (A).

(A) Mount lower case

(B) Rubber spacer

(C) Frame

(D) Frame mounting hole

1

2

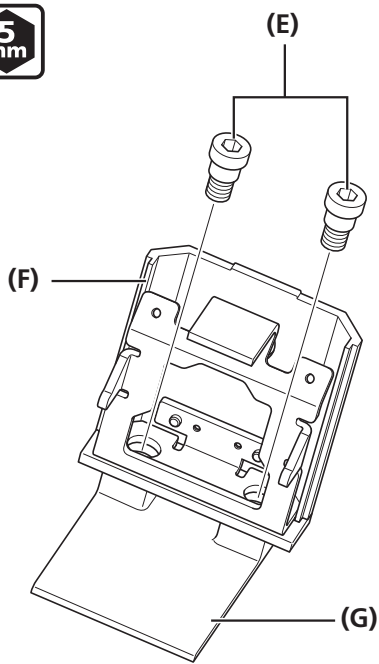

Secure the mount lower case (F) to the frame by the tightening the mount fixing bolts (M8) (E).

- (E) Mount fixing bolt (M8)
- (F) Mount lower case
- (G) Frame

Tightening torque



10 N·m

3

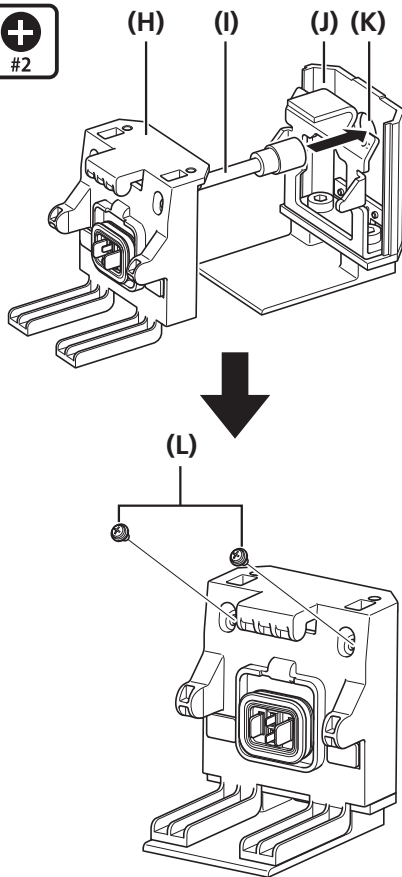

Route the power cord (I) through the cable routing hole (K) in the mount lower case (J) and then tighten on the mount upper case (H) using the mount upper case fixing bolts (M3) (L).

- (H) Mount upper case
- (I) Power cord
- (J) Mount lower case
- (K) Cable routing hole
- (L) Mount upper case fixing bolt (M3)

Tightening torque



0.6 N·m

▶▶ Installing the battery mount

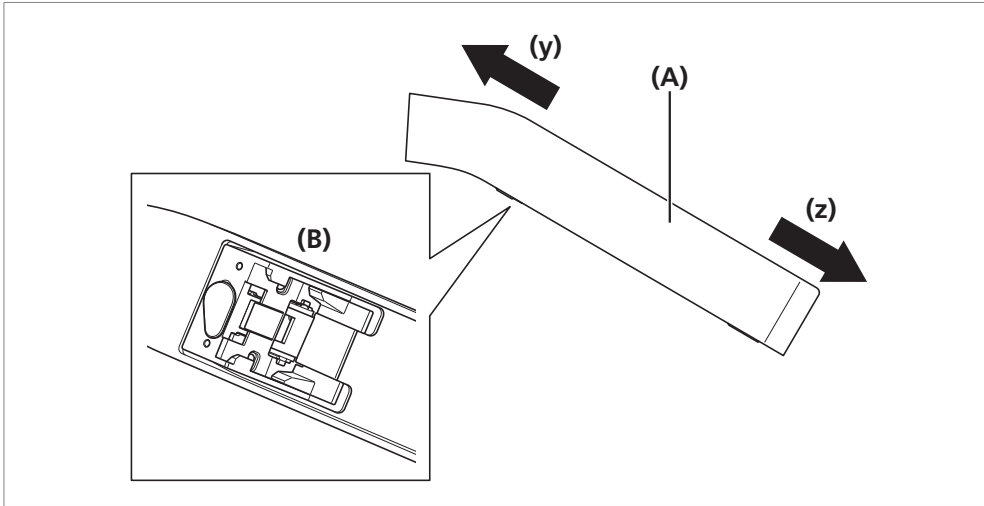

(y) Front of bicycle

(z) Rear of bicycle

(A) Frame

(B) Key unit

4

Insert the key cylinder (M) into the key unit.

Secure the key cylinder (M) in place by tightening the key cylinder fixing bolts (M4) (O) from the reverse side of the key unit (N).

(z) Reverse side of key unit

(M) Key cylinder:
Key cylinder is not included with SHIMANO products.

(N) Key unit

(O) Key cylinder fixing bolt (M4)

Tightening torque	
	0.6 N·m

▶ Installing the battery mount

5

Align the fixing bolt holes in the key unit (P) with the frame mounting holes (T).

Temporarily attach the key unit (P) to the frame (S) with the key unit fixing bolts (M8) (Q).

Attach the bolt fork end prevention rubbers (R).

- (P) Key unit
- (Q) Key unit fixing bolt (M8)
- (R) Bolt fork end prevention rubber
- (S) Frame
- (T) Frame mounting hole

6

Adjust the position of the key unit so that the distance between section (c) of the key unit and section (d) of the battery connection unit is 347.9 mm and then fully tighten the key unit fixing bolts (Q).

Tightening torque	
	10 N·m

7

Temporarily attach the key unit cover (U) to the key unit and adjust so that the battery (V) can be smoothly connected/disconnected and no noise is produced due to looseness during riding.

- (U) Key unit cover
- (V) Battery

Attaching/detaching the battery on downward attachment/removal design frames

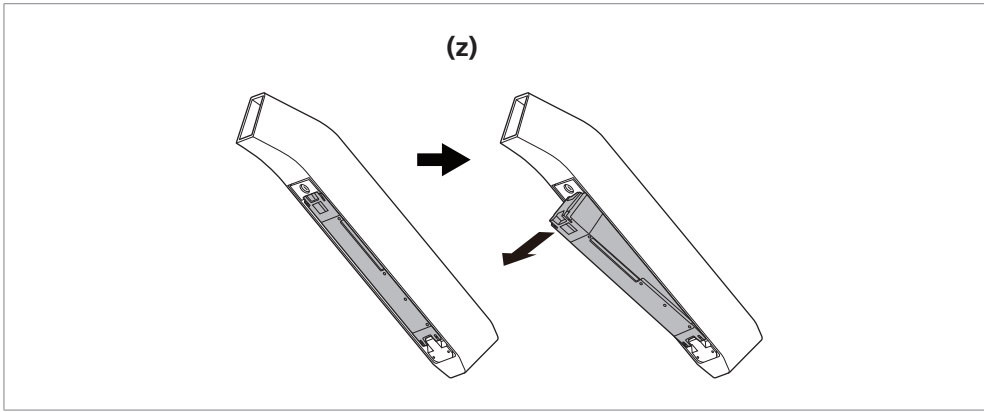

(z) Downward attachment/
removal design frame

8

Use key unit cover A **(W)** with the indication marking A and make sure to attach the plate spring **(Z)**.

Attach key unit cover A **(W)** to the key unit **(X)**.

Secure in place the key unit **(X)** with the key unit cover fixing bolts (M3) **(Y)**.

Secure the plate spring **(Z)** in place by tightening the plate spring fixing bolt **(AA)**.

- (W)** Key unit cover A
- (X)** Key unit
- (Y)** Key unit cover fixing bolt (M3)
- (Z)** Plate spring
- (AA)** Plate spring fixing bolt

Tightening torque	
	(Y), (AA) 0.6 N·m

Attaching/detaching the battery on upward attachment/removal design frames

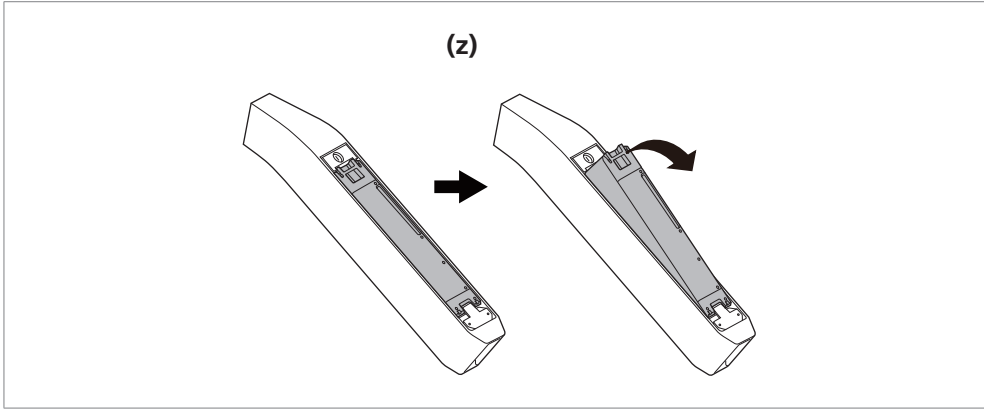

(z) Upward attachment/
removal design frame

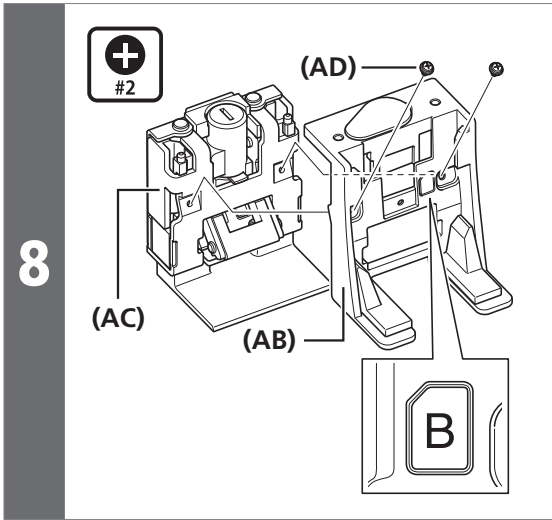

Make sure to use key unit cover B **(AB)** with the indication marking B.

Attach key unit cover B **(AB)** to the key unit **(AC)**.

Secure in place the key unit **(AC)** with the key unit cover fixing bolts (M3) **(AD)**.

(AB) Key unit cover B

(AC) Key unit

(AD) Key unit cover fixing bolt (M3)

Tightening torque	
	0.6 N·m

NOTE

Do not attach a plate spring when using an upward attachment/removal design frame.

■ Installing the battery

BT-E6000/BT-E6001/SM-BME60/BM-E6000

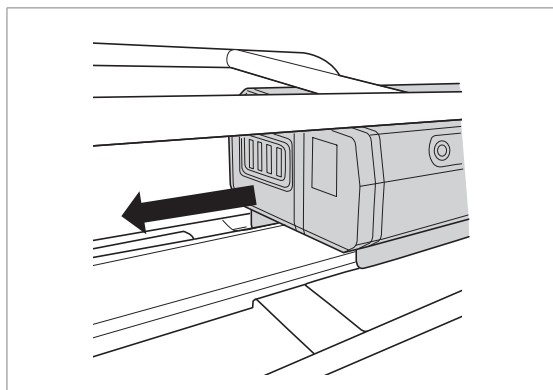

Set the battery on the mount rail from behind and slide it forward. Push it firmly into place.

NOTE

To prevent the battery from falling off, check to see that the battery is locked after installation.

BT-E6010/SM-BME61/BM-E6010/BT-E8010/BM-E8010

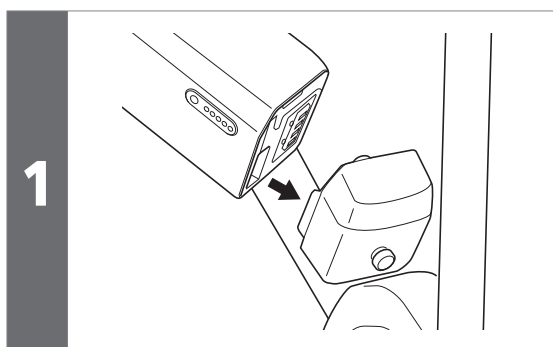

Align the indentation in the bottom of the battery with the protrusion on the mount and insert the battery.

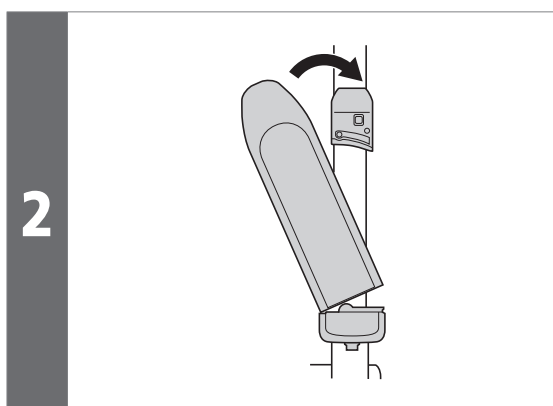

Slide the battery to the right starting from the point where it is inserted. Push it firmly into place.

NOTE

- To prevent the battery from falling out, check to see that the battery is locked after installation.
- Before riding, make sure that the charging port cap is closed.
- To prevent the battery from falling out, do not ride the bicycle with the key inserted.

BT-E8020/BM-E8020

For the purposes of demonstration, these instructions take as an example a frame design where the battery is removed/installed from below.

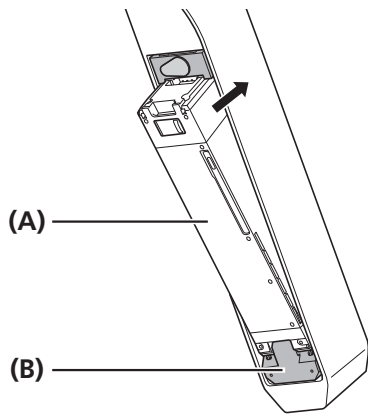

Insert the battery (A) into the battery mount (B) until there is a click.

- When inserted until a click is heard, the battery is locked automatically.

(A) Battery

(B) Battery mount

NOTE

- To prevent the battery from falling out, check to see that the battery is locked after installation.
- Before riding, make sure that the keyhole cap and charging port cap are closed.
- To prevent the battery from falling out, do not ride the bicycle with the key inserted.

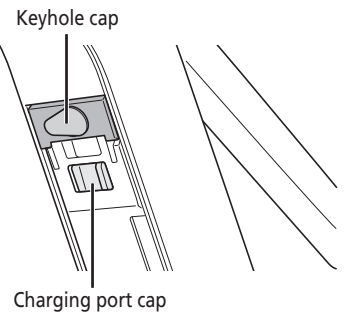

■ Removing the battery

BT-E6000/BT-E6001/BT-E6010/BT-E8010

The following description may not be applicable as different types of keys are available.

1

<BT-E6000/BT-E6001>

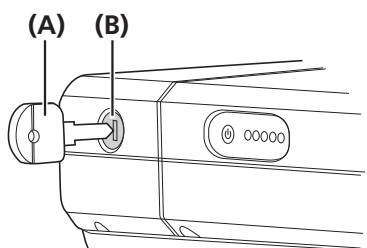

(A) (B)

<BT-E6010/BT-E8010>

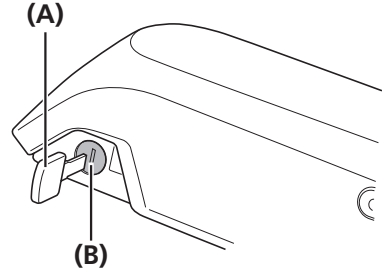

(A) (B)

Turn off the power, then insert the key (A) into the key cylinder (B) in the battery holder.

- (A) Key
- (B) Key cylinder

 **TECH TIPS**

- The position of the key does not affect the insertion of the battery. You can insert it regardless of the key position.
- You cannot remove the key when it is not in the inserting position.

2

<BT-E6000/BT-E6001>

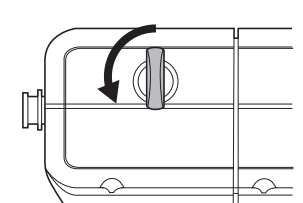

(A)

<BT-E6010/BT-E8010>

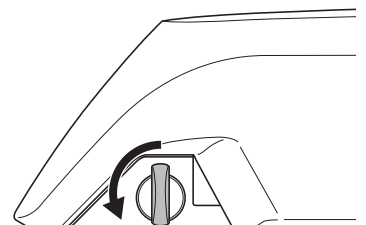

(A)

To unlock the battery turn the key (A) to the left until you feel some resistance.

3

<BT-E6000/BT-E6001>



Pull out the battery.

 **TECH TIPS**

- You can remove the battery only when the key is in the unlocking position.

▶ Removing the battery

3	<p><BT-E6010/BT-E8010></p>	<p>Hold the upper part of the battery and slide it to the left to remove it.</p>
---	----------------------------------	----------------------------------------------------------------------------------

NOTE

Hold the battery firmly and be careful that it does not drop when removing or carrying it.

BT-E8020

- For the purposes of demonstration, these instructions take as an example a frame design where the battery is removed/installed from below.
- If using a battery cover manufactured by another company, remove the battery cover before removing the battery.

1		<p>Remove the keyhole cap (A).</p>
---	--	------------------------------------

(A) Keyhole cap

2		<p>Insert the key (B) into the key cylinder (C) in the battery mount.</p>
---	--	---------------------------------------------------------------------------

(B) Key
(C) Key cylinder

TECH TIPS

- The position of the key does not affect the insertion of the battery. You can insert it regardless of the key position.
- You cannot remove the key when it is not in the inserting position.

3		<p>To unlock the battery, turn the key (B) clockwise and push it in. When the battery lock is unlocked, the plate spring holds the battery in place, preventing it from falling out.</p>
---	--	------------------------------------------------------------------------------------------------------------------------------------------------------------------------------------------

▶▶ Removing the battery

4

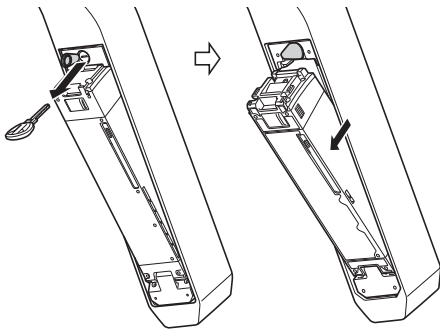

Remove the key (B) from the key cylinder (C), close the keyhole cap (A), and detach the battery.

NOTE

- Support the battery with your hand when detaching to make sure that it does not fall out.
- Do not attach or detach the battery with the key left inserted into the key cylinder or the keyhole cap left open. The battery may be damaged from contact with the handle of the key or the keyhole cap.

■ Installing the speed sensor

SM-DUE10

1

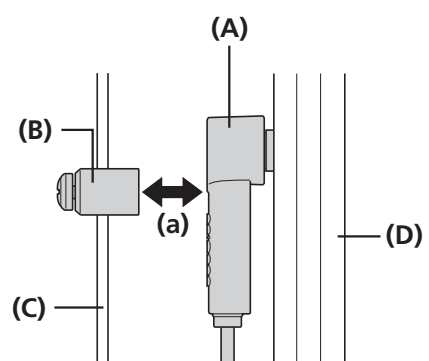

Before installing the speed sensor (A), check that the clearance (a) between the speed sensor and the magnet unit (B) will be within 3 to 17 mm.

- (A) Speed sensor
- (B) Magnet unit
- (C) Spoke
- (D) Chain stay



When checking the clearance is within 17 mm, take wheel truing, frame distortion, etc. into account.

2

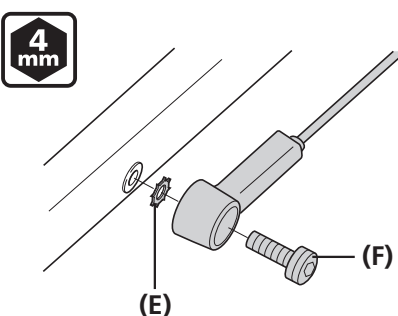

If the clearance is within the designated range, place the toothed washer (E) between the speed sensor and the chain stay, then attach the speed sensor fixing bolt (F).

- (E) Toothed washer
- (F) Speed sensor fixing bolt (16 mm)

Tightening torque

	1.5 - 2 N·m
--------------------------------------------------------------------------------------	-------------

3

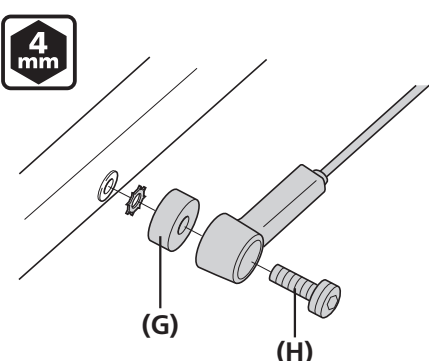

If the clearance exceeds 17 mm, use a spacer (G) to adjust it. Attach the speed sensor with the speed sensor fixing bolt (H).

- (G) Spacer
- (H) Speed sensor fixing bolt (22 mm)

Tightening torque

	1.5 - 2 N·m
---------------------------------------------------------------------------------------	-------------

SM-DUE11

#10

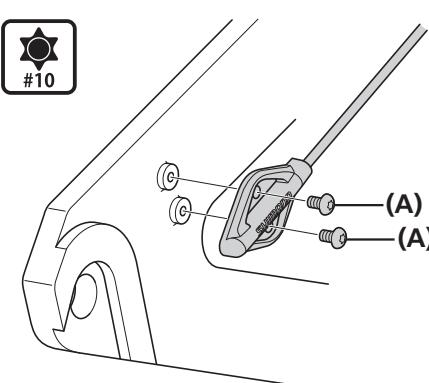

Install the speed sensor with the 2 speed sensor fixing bolts.

- (A) Speed sensor fixing bolt

Tightening torque

	0.6 N·m
---------------------------------------------------------------------------------------	---------

■ Mounting the magnet

SM-DUE10

Magnet mounting position

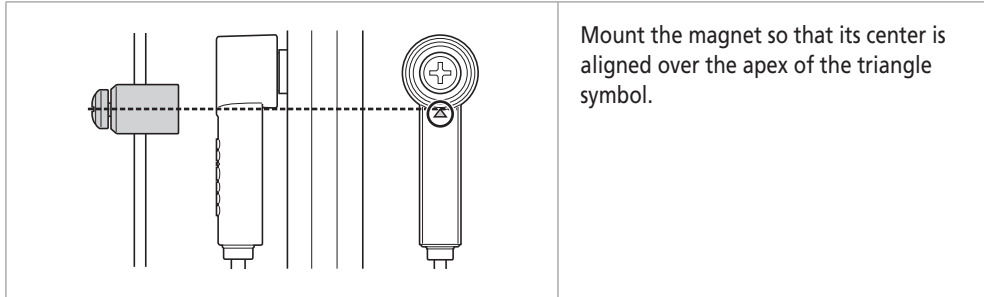

Mount the magnet so that its center is aligned over the apex of the triangle symbol.

How to mount the magnet

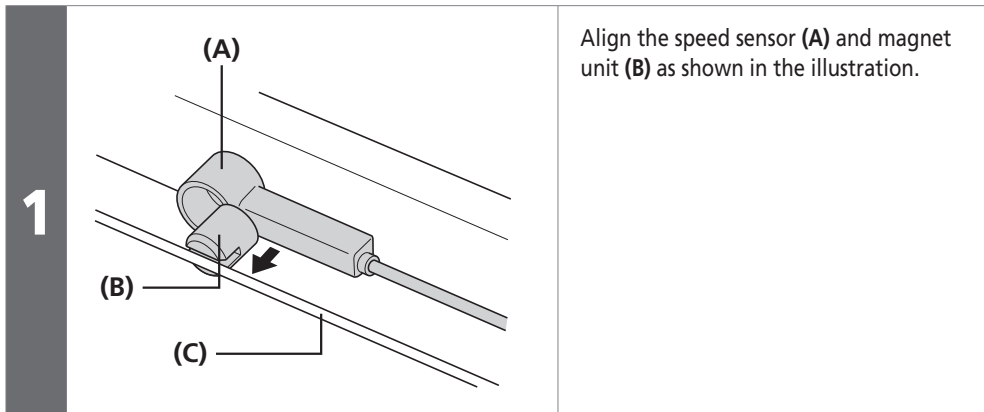

- (A) Speed sensor
- (B) Magnet unit
- (C) Spoke

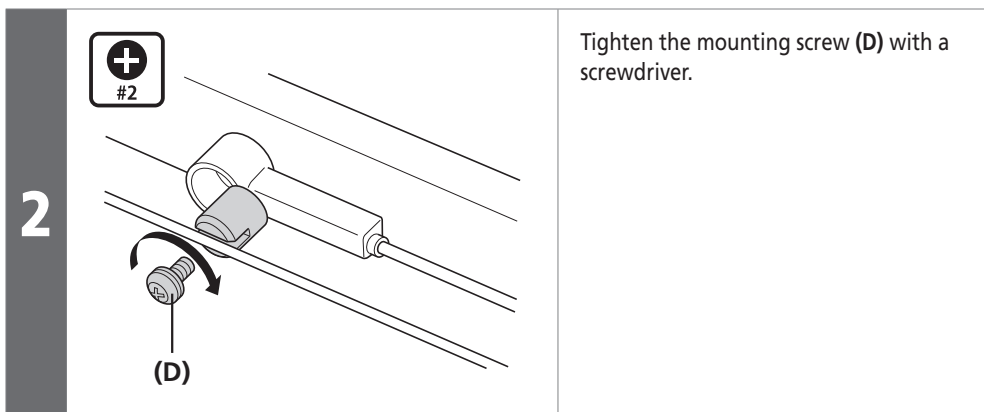

- (D) Mounting screw

Tightening torque	
	1.5 - 2 N·m

SM-DUE11

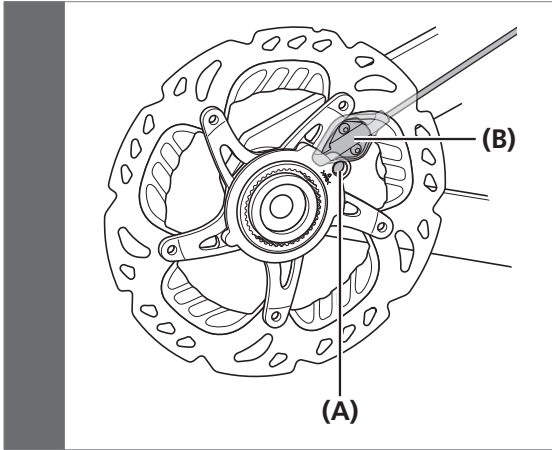

Use the special magnet model for the disc brake rotor.

(A) Magnet unit

(B) Speed sensor

NOTE

Refer to General Operations for installation of the disc brake rotor.

Chapter2 INSTALLING AND WIRING THE DRIVE UNIT

INSTALLING AND WIRING THE DRIVE UNIT

■ Installing the drive unit

1

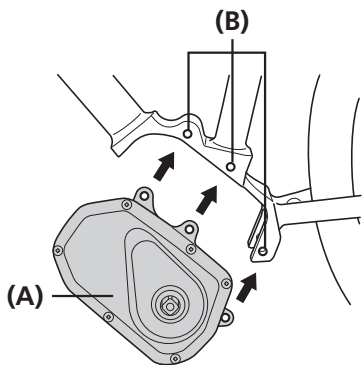

Align the three mounting holes (B) in the drive unit (A) with those in the frame.

- (A) Drive Unit
- (B) Mounting hole

NOTE

Be careful not to pinch the cables with the frame or drive unit case.

2

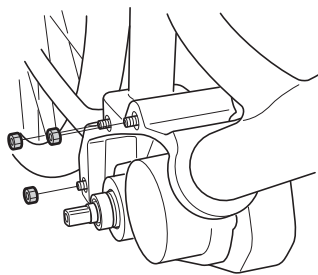

Insert M8 bolts, attach nuts from the opposite side, and tighten them to the designated torque.



TECH TIPS

Bolts and nuts are not included with SHIMANO products. Use those supplied by the manufacturer. For information on the tightening torques, contact the manufacturer.

▶▶ Drive unit wiring diagram

■ Drive unit wiring diagram

Below is an example of wiring on a carrier type battery.

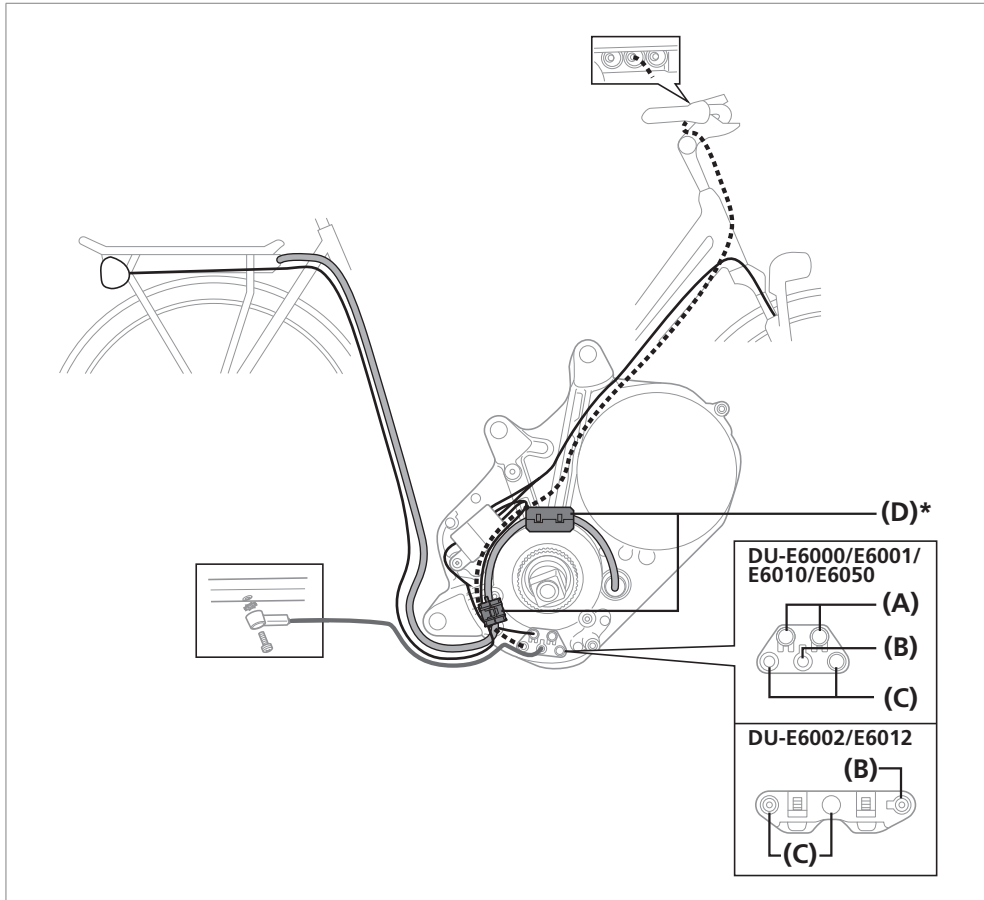

- (A) Light connector
- (B) Speed sensor connector
- (C) E-TUBE connector for cycle computers, motor units and rear derailleurs
- (D) Ferrite core*
 - * May not be included, depending on the product's specifications.

NOTE

Be sure to attach dummy plugs to any unused ports.

TECH TIPS

- The left illustration shows an example of wiring.
- The light connector can be used through both ports (A).
- The E-TUBE connector for cycle computers and motor units can be used through both ports (C).

▶▶ Connecting the power cord

■ Connecting the power cord

Connecting to the drive unit

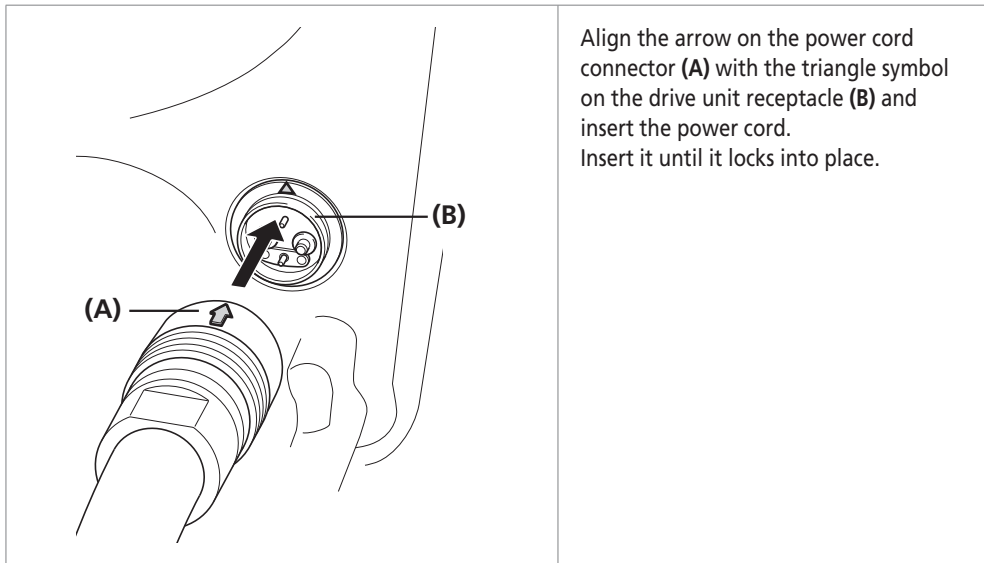

- (A) Power cord connector
- (B) Drive unit receptacle

Disconnecting from the drive unit

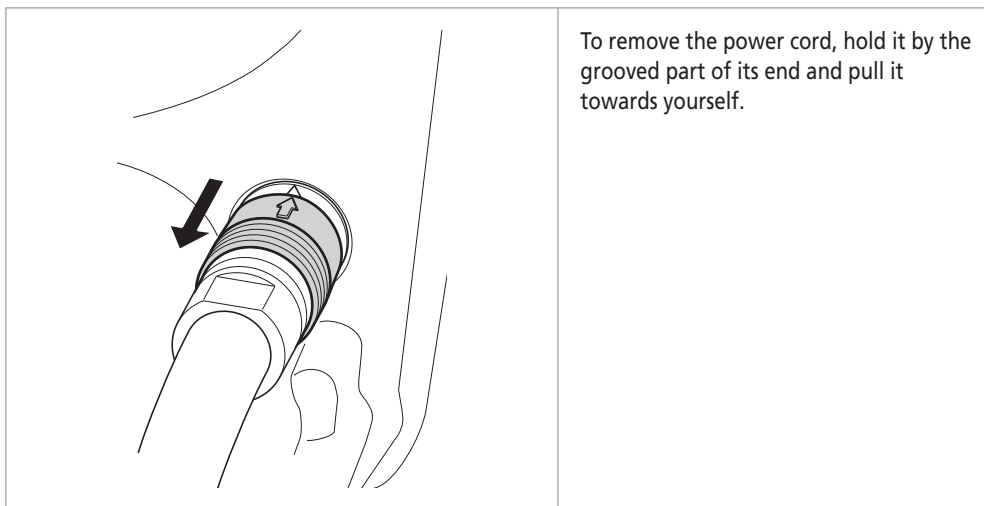

▶▶ Installing the ferrite core (DU-E6001/E6010/E6050)

■ Installing the ferrite core (DU-E6001/E6010/E6050)

If a ferrite core is included with unit or battery mount, install it by following the procedure described below. Depending on the specifications, a ferrite core may not be included with drive unit, so installation is not required.

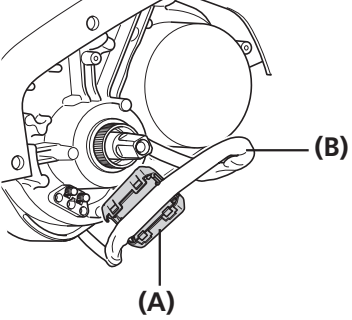
1		<p>Install the ferrite core (A) on the power cord (B).</p>
---	-----------------------------------------------------------------------------------	------------------------------------------------------------

- (A) Ferrite core
- (B) Power cord

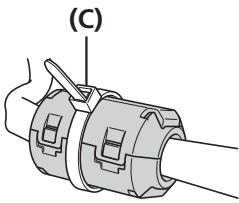
2		<p>Make sure that the power cord is not pinched and firmly secure the ferrite core. Then, fix the ferrite core with the zip tie (C).</p>
---	------------------------------------------------------------------------------------	------------------------------------------------------------------------------------------------------------------------------------------

- (C) Zip tie

NOTE

- Check that the ferrite core tabs are firmly secured.
- Do not cut off the excess portion of the zip tie. The cut surface of the zip tie may scratch the cable or case.
- Do not drop the ferrite core or subject it to any shocks. Subjecting the ferrite core to shocks will cause it to break or crack, rendering it unusable.

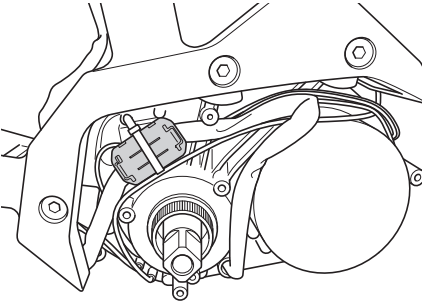
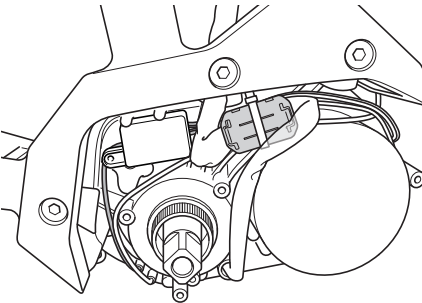
3	<p><SM-BME60></p>  <p><SM-BME61></p> 	<p>Position the ferrite core so that the power cord fits inside the drive unit.</p>
---	-------------------------------------------------------------------------------------------------------------------------------------------------------------------------------------------------------------------------	-------------------------------------------------------------------------------------

▶▶ Connecting the electric wire

■ Connecting the electric wire

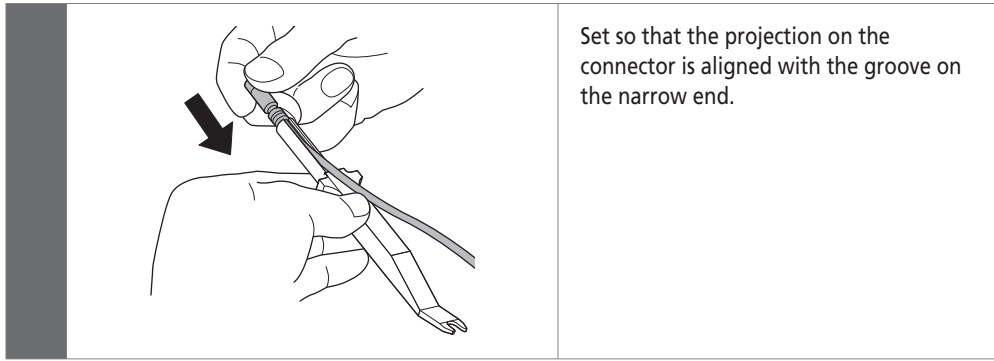

Set so that the projection on the connector is aligned with the groove on the narrow end.

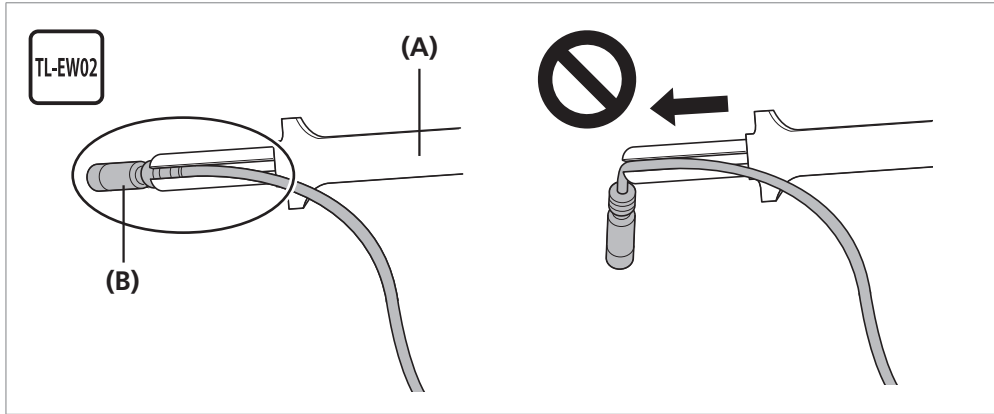

- (A) TL-EW02
- (B) Plug

NOTE

Use the SHIMANO original tool for installation and removal of the electric wire. When installing the electric wire, do not forcibly bend the plug. It may result in a poor contact. When connecting the electric wire, push it in until it clicks in place.

■ Connecting the assist switch and drive unit to the cycle computer

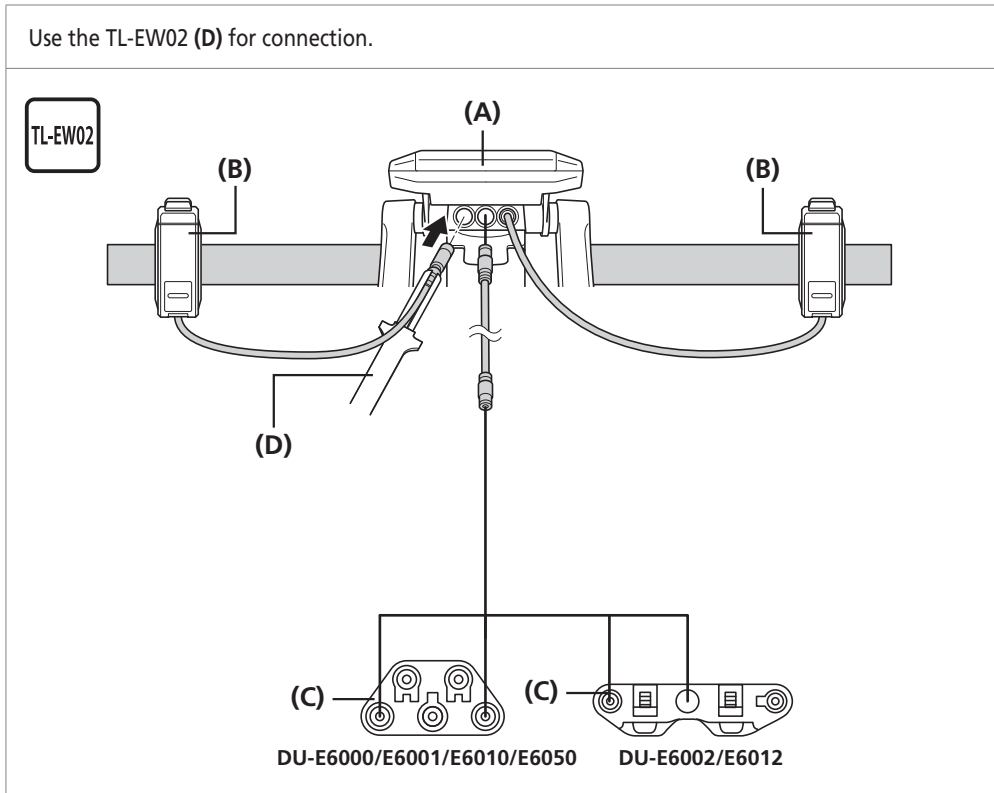

- (A) Cycle computer
- (B) Assist/Shift switch
- (C) Drive Unit
- (D) TL-EW02

TECH TIPS

The electric wire connector can be connected to any port of the cycle computer, but we recommend you connect the assist switch to the switch-side port.

▶▶ Connecting the speed sensor to the drive unit

■ Connecting the speed sensor to the drive unit

Connect the speed sensor unit electric wire to the drive unit speed sensor connector (B) using the TL-EW02 (A).

- (A) TL-EW02
- (B) Speed sensor connector

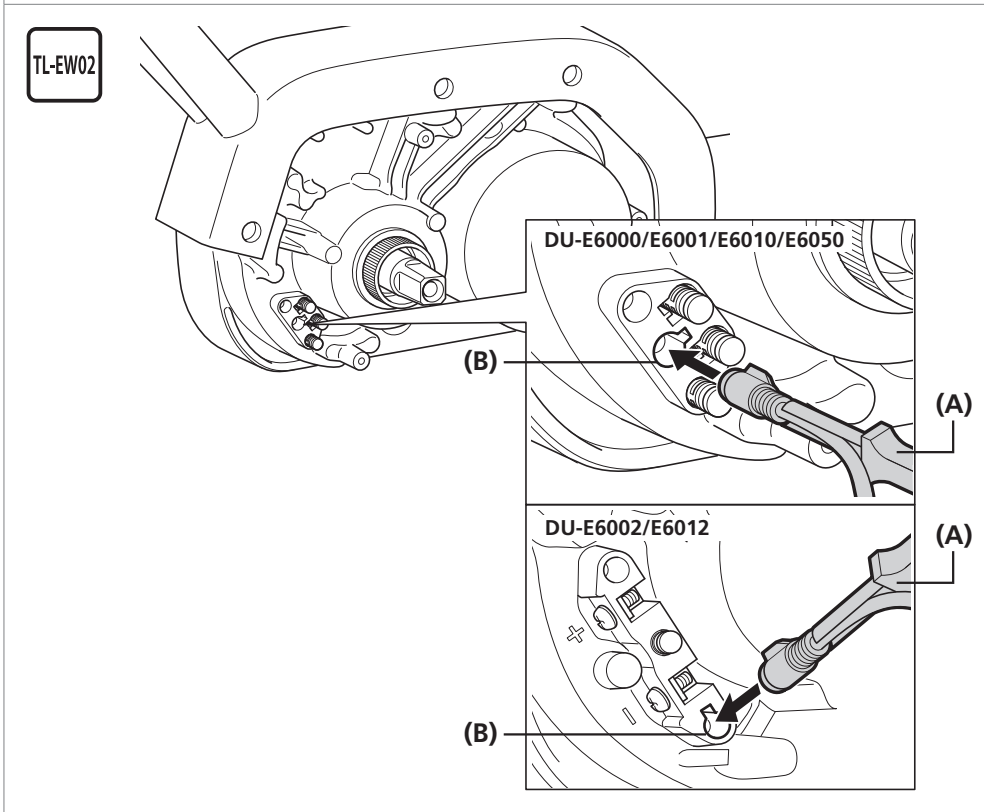

■ Connecting the light to the drive unit

DU-E6002/E6012

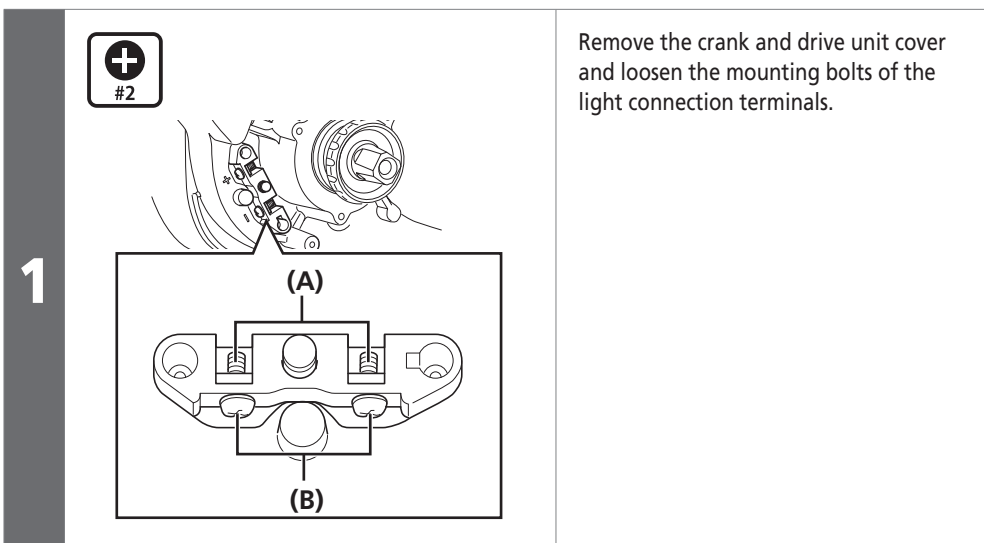

- (A) Light connection terminal
- (B) Mounting bolt



For information on compatible lights, contact a manufacturer of completed bicycles.

▶ Connecting the light to the drive unit

2

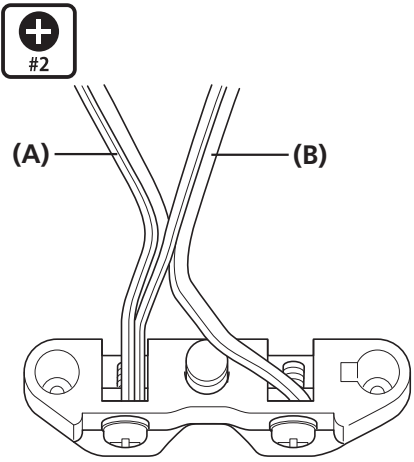

Attach the front light cable and tail light cable to the terminals and secure them with the mounting bolts.

- (A) Front light cable
- (B) Taillight cable

Tightening torque	
	0.6 N·m

DU-E6000/E6001/E6010/E6050

To connect the light using the light adapter, carry out wiring as follows.

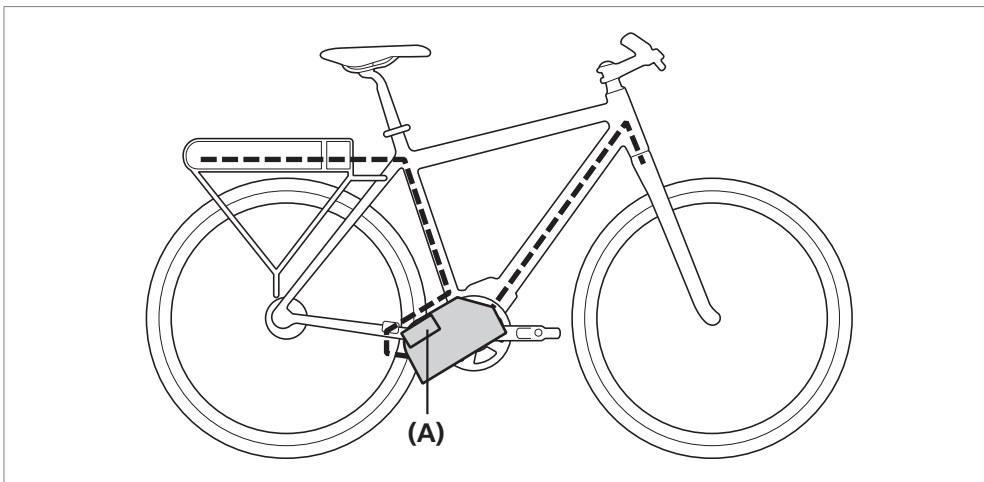

- (A) Light adapter

1

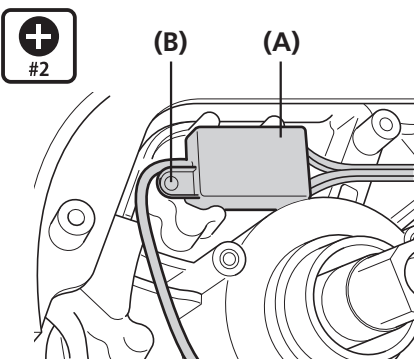

Attach the light adapter (A) in the direction shown in the illustration. Secure it to the drive unit with the unit fixing screw (B).

- (A) Light adapter
- (B) Unit fixing screw

Tightening torque	
	0.6 N·m

▶ Connecting the light to the drive unit

2

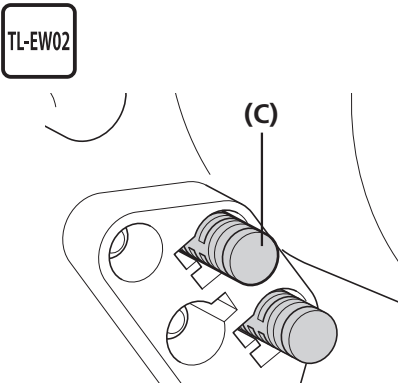

TL-EW02

(C)

Remove the dummy plug (C) from the drive unit with TL-EW02.

(C) Dummy plug

3

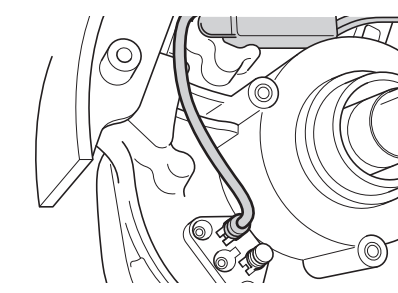

Attach the connector of the light adapter to the drive unit.

4

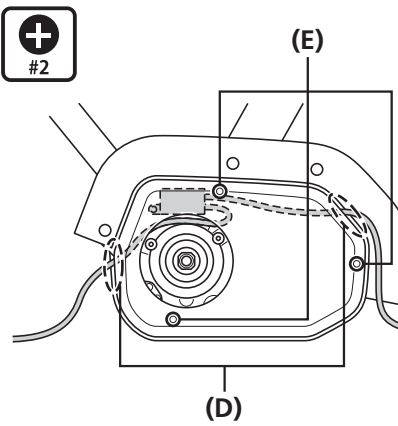

#2

(E)

(D)

Pass the front light and tail light cables through the cable holes (D) and attach the cover.
Tighten the cover fixing bolts (E) in the three locations.

(D) Cable holes
(E) Cover fixing bolt (M3)

Tightening torque	
#2	0.6 N·m

5

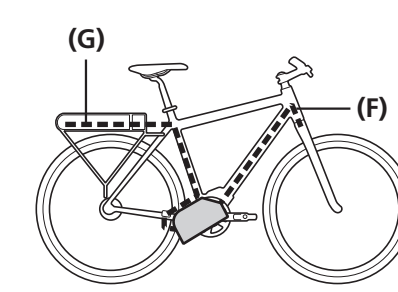

(G)

(F)

Fix the light cables to the electric wire around the light adapter and route them along the frame.

(F) Front light cable
(G) Taillight cable

 **TECH TIPS**

For information on compatible lights, contact a manufacturer of completed bicycles.

▶▶ Installing the ferrite core (MU-S705)

■ Installing the ferrite core (MU-S705)

If a ferrite core is included with MU-S705, install it by following the procedure described below. Depending on the specifications, a ferrite core may not be included with MU-S705, so installation is not required.

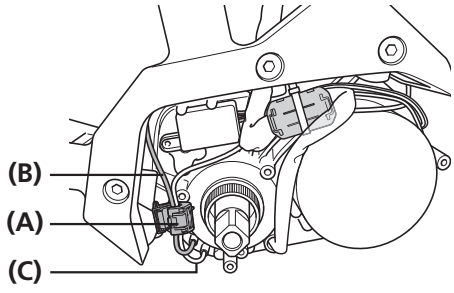
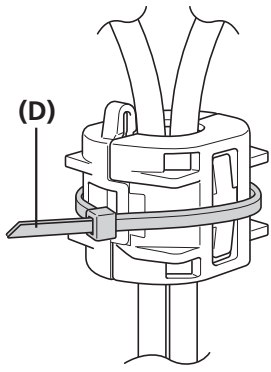
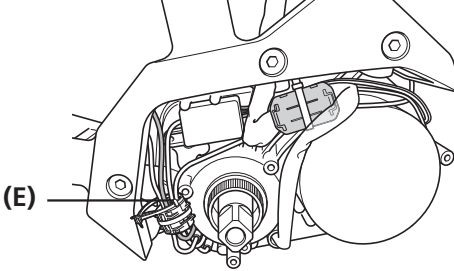
<p>1</p>		<p>Install the ferrite core (A) onto electric wire for motor unit (B) and electric wire for cycle computer (C).</p>	<p>(A) Ferrite core (B) Electric wire (EW-SD50) for motor unit (C) Electric wire (EW-SD50) for cycle computer</p>
<p>2</p>		<p>Make sure that the electric wires are not pinched and firmly secure the ferrite core. Then, fix the ferrite core with the zip tie (D). The zip ties are included with MU-S705.</p>	<p>(D) Zip tie</p> <p style="text-align: center;">NOTE</p> <ul style="list-style-type: none"> • Check that the ferrite core tabs are firmly secured. • Do not cut off the excess portion of the zip tie. The cut surface of the zip tie may scratch the cable or case. • Do not drop the ferrite core or subject it to any shocks. Subjecting the ferrite core to shocks will cause it to break or crack, rendering it unusable.
<p>3</p>		<p>Pass the zip tie through projection (E) located at the top of the ferrite core. Bundle together the electric wires and peripheral wires, and fix them with the zip tie.</p>	<p>(E) Projection</p>

■ Installing the crank and front chainring

Perform the procedure below for all models, regardless of whether with powered or mechanical gear shifting.

1

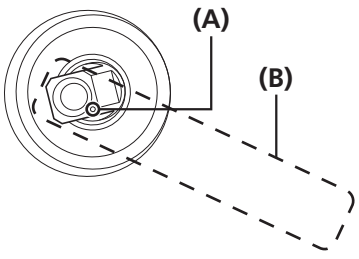

Install the left crank arm. Align the round indentation (A) on the square spindle with the installation direction of the crank arm (B) as shown in the illustration.

- (A) Indentation
- (B) Installation direction of the crank arm

2

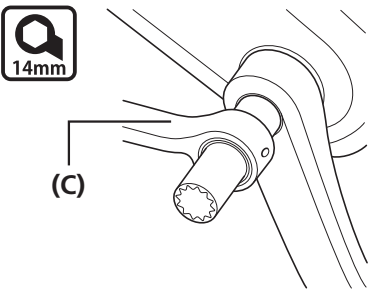

Attach the crank arm fixing bolt and tighten it with a 14 mm socket wrench (C).

- (C) 14 mm socket wrench

Tightening torque	
	35 - 50 N·m

3

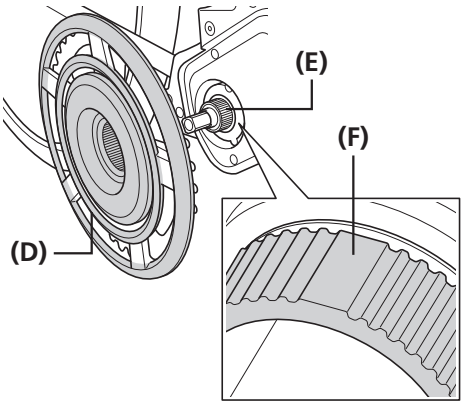

Align the cutout in the front chainring (D) with the wide area (F) on the chainring installation part (E) when inserting the front chainring.

<In the case of DU-E6000>

- When installing a front chainring labeled "SM-CRE60", a spacer needs to be placed between the front chainring and the chainring installation part. In this case, consult an agency.

<For the DU-E6001/E6010/E6050/E6002/E6012>

- This can be attached only on front chainrings labeled "SM-CRE60".
- There are also models without a wide area. For those models, positioning is not needed to install the front chainring.

- (D) Front chainrings
- (E) Chainring installation part
- (F) Wide part

▶▶ Installing the crank and front chainring

4

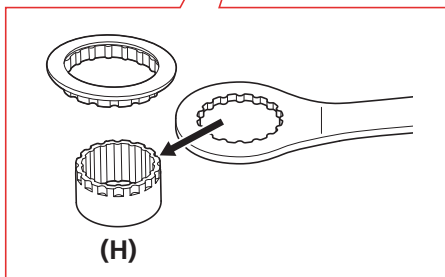
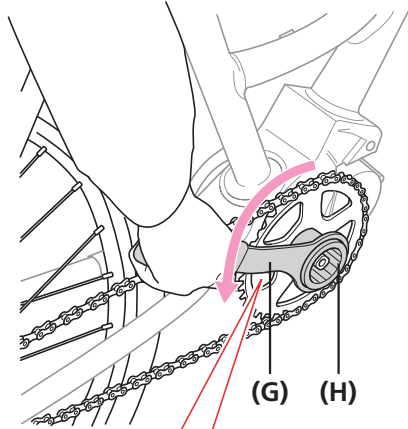

Tighten the lock ring by hand and attach the SHIMANO original tool. While holding the left crank, tighten the lock ring in the direction shown in the illustration.

(G) TL-FC32 / FC36

(H) TL-FC38

Tightening torque



35 - 45 N·m

NOTE

If using a torque wrench, use TL-FC38 in combination with TL-FC33.

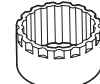

TL-FC38

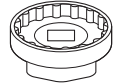

TL-FC33

* An impact wrench cannot be used.



TECH TIPS

The lock ring has a left hand thread.

5

Insert the right crank arm attach the crank arm fixing bolt, and tighten it. Finally, attach the crank arm cap.

Tightening torque



35 - 50 N·m

6

After installing the crank arm, rotate the crank to check that it rotates smoothly.

▶▶ Measuring and adjusting the chain tension

■ Measuring and adjusting the chain tension

When using an internal geared hub, it is necessary to adjust the chain tension.

Measure and adjust the chain tension manually.

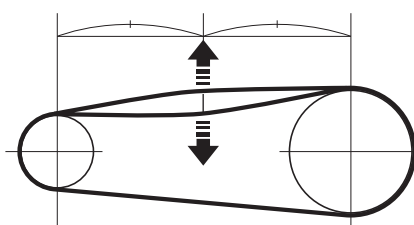
1		<p>Set the chain in place and pull it up and down with a force of about 10 N (1 kg).</p>
---	-----------------------------------------------------------------------------------	------------------------------------------------------------------------------------------

2	<p>Adjust so that there is 15 mm or more of slack in the chain.</p>
---	---------------------------------------------------------------------

Measure and adjust chain tension with the chain tension measurement tool (TL-DUE60).

Set the chain in place, then apply pressure from the top or bottom of the chain with the chain tension measurement tool.

When measuring and adjusting the chain tension from the top of the chain:

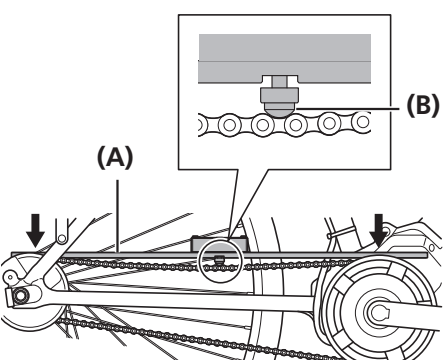
1		<p>Place the chain tension measurement tool (A) against the top of the chain and press down until it touches the front chainring and rear sprocket.</p>
---	------------------------------------------------------------------------------------	---------------------------------------------------------------------------------------------------------------------------------------------------------

-
- (A) Chain tension measurement tool (TL-DUE60)
 - (B) Projection part
-

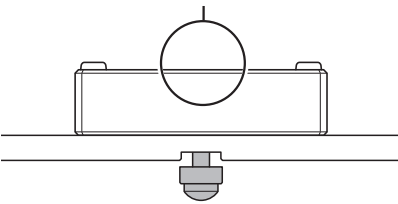
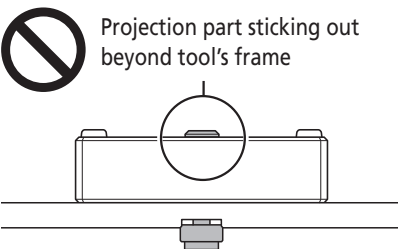
2	<p>Projection part not sticking out beyond tool's frame</p>  <p>Projection part sticking out beyond tool's frame</p> 	<p>Adjust the chain tension so that the projection part (B) does not stick out at all from the chain tension measurement tool's frame section.</p>
---	---------------------------------------------------------------------------------------------------------------------------------------------------------------------------------------------------------------------------------------------------------------------------------------------	----------------------------------------------------------------------------------------------------------------------------------------------------

▶ Measuring and adjusting the chain tension

When measuring and adjusting the chain tension from the bottom of the chain:

1

Place the chain tension measurement tool (A) against the bottom of the chain and press up until it touches the front chainring and rear sprocket.

(A) Chain tension measurement tool (TL-DUE60)
(B) Projection part

2

Part (z) not hidden by tool's frame

Adjust the chain tension so that part (z) of the projection part (B) is not hidden by the chain tension measurement tool's frame.

Part (z) hidden by tool's frame

Chapter3 CHARGING THE BATTERY

CHARGING THE BATTERY

■ Introduction

The battery cannot be used immediately after purchase as it will be in deep sleep mode. Charging the battery with the dedicated battery charger will release the battery from deep sleep mode, allowing the battery to be used. The battery can be used when the LED on it turns on. The battery can also be released from deep sleep mode by connecting to E-TUBE PROJECT when the bicycle is fitted with all components.

■ Proper use of the battery

Charging can be carried out at any time regardless of the amount of charge remaining, but you should fully charge the battery in the following cases. Be sure to use the dedicated charger to charge the battery.

- The battery is uncharged at the time of shipment. Before riding, be sure to charge the battery until it is fully charged.

If the battery has become completely discharged, charge it as soon as possible. If you leave the battery uncharged, the battery may deteriorate.

- If the bicycle will not be ridden for a long time, store with the battery level at around 70%.

Charge the battery every six months to prevent it from fully discharging.

- Do not connect to E-TUBE PROJECT while the battery is being charged.

The use of a genuine SHIMANO battery is recommended. If using a battery from another manufacturer, make sure to carefully read the instruction manual for the battery before use.

- Connect to E-TUBE PROJECT and click [Connection check] to confirm whether the battery in use is a genuine SHIMANO battery or another brand.

■ Charging procedures

When charging the battery alone

<EC-E6000>/<BT-E6000/BT-E6001/BT-E6010>

1

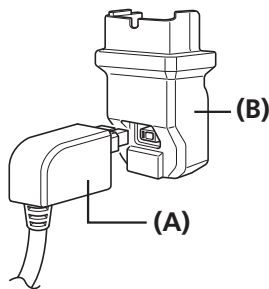

Attach the adapter (B) to the battery charger's charging plug (A).

(A) Charging plug
(B) Adapter

2

Connect the battery charger's power plug to the outlet.

▶ Charging procedures

3

<BT-E6000/BT-E6001>

<BT-E6010>

Insert adapter (B) into the battery's charging port (C).

- * When inserting the adapter into the charging port, insert it so that the charging plug is positioned below the adapter. The adapter cannot be inserted if the charging plug is above the adapter.
- * Charge the battery on a flat surface indoors.

- (C) Charging port
- (D) Battery

<EC-E6000>/<BT-E8010/BT-E8020>

1 Connect the battery charger's power plug to the outlet.

2

<BT-E8010>

<BT-E8020>

Insert the charging plug (A) into the battery's charging port (B).

- (A) Charging plug
- (B) Charging port
- (C) Battery

NOTE

Charge the battery on a flat surface indoors.

<SM-BCE60>/<BT-E6000/BT-E6001/BT-E6010>

<BT-E6000/BT-E6001>

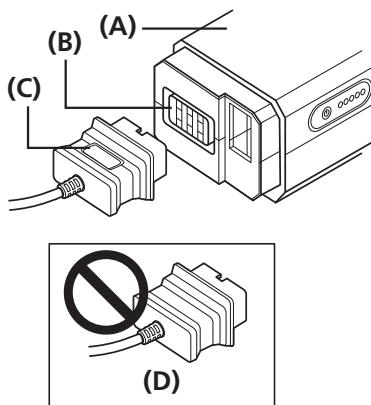

Attach the charger plug to the charging port (B) of the battery (A). Insert it with the groove (C) side of the plug facing the direction shown in the illustration.

- (A) Battery
- (B) Charging port
- (C) Groove
- (D) Back side (No groove)

<BT-E6010>

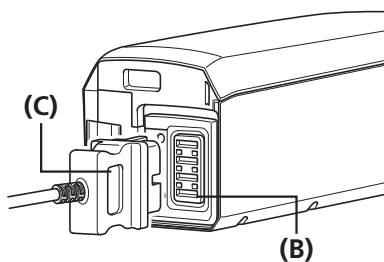

When charging the battery while it is mounted on the bicycle

<EC-E6000>/<BT-E6000/BT-E6001/BT-E6010/BT-E8010/BT-E8020>

- 1 Connect the charger's power plug to the outlet.

Insert the charging plug (C) into the charging port (B) on the battery mount (A) or the battery (D).

- * Place the battery charger on a steady surface such as the floor before charging.
- * Stabilize the bicycle to ensure that it does not collapse during charging.

- (A) Battery mount
- (B) Charging port
- (C) Charging plug
- (D) Battery

<BT-E6000/BT-E6001>

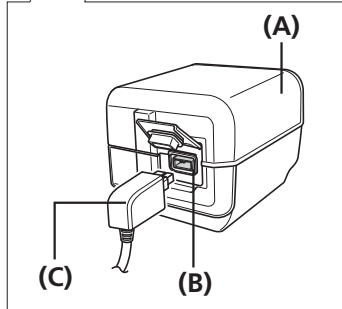
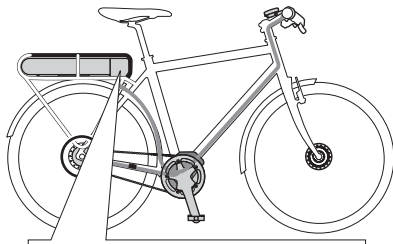

<BT-E8020>

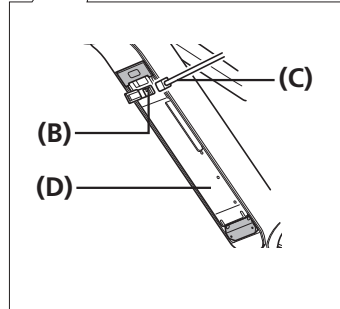
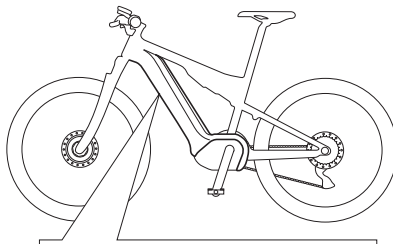

<BT-E6010/BT-E8010>

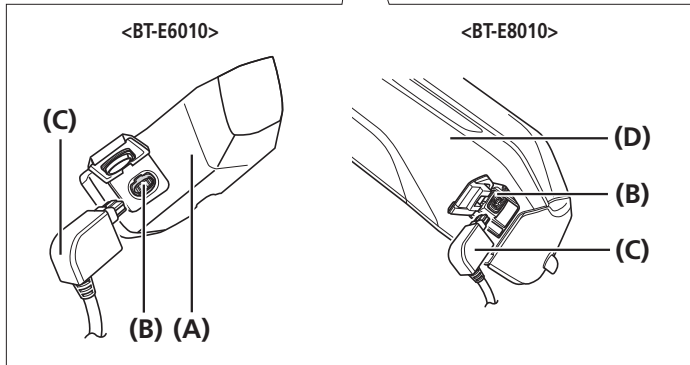
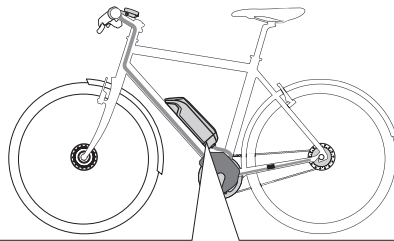

About the charger LED lamp

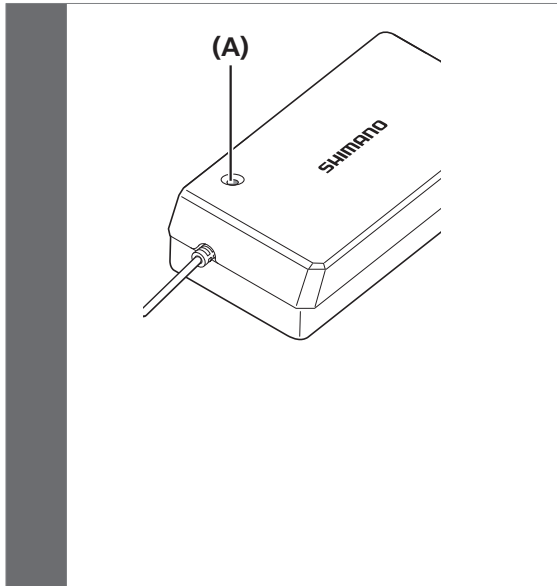

After charging has started, the LED lamp (A) on the charger lights up.

Lit up	Charging (Within 1 hour after the completion of charging)
Blinking	Charging error
Turned off	Battery disconnected (1 hour or more after the completion of charging)

(A) Charger LED lamp

DANGER

Use the battery and charger combination specified by the company for charging and follow the charging conditions specified by the company. Not doing so may cause overheating, bursting, or ignition of the battery.

NOTE

If the bicycle is stored for an extended period of time immediately after purchase, you will need to charge the battery before using the bicycle. Once the battery is charged, it starts to deteriorate slightly.

About the battery LED lamps

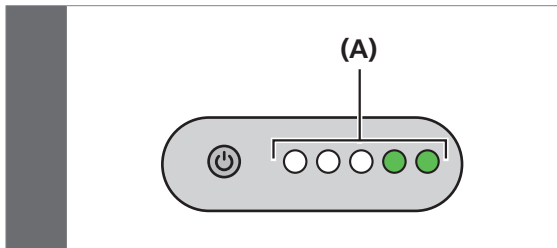

You can check the current charging status on the battery level lamp (A) located on the battery.

(A) Battery LED lamp

Charging-in-progress indication

Battery level indication*1	Battery level
	0 - 20%
	21 - 40%
	41 - 60%
	61 - 80%
	81 - 99%
	100%

*1 ●: Not lit ●: Lit up : Blinking

Battery level indication

The current battery level can be checked by pressing the battery's power button.

Battery level indication*1	Battery level
	100 - 81%
	80 - 61%
	60 - 41%
	40 - 21%
	20 - 1%
	0% (When battery is not installed on bicycle)
	0% (When battery is installed on bicycle) Power off / Shutdown

*1 ●: Not lit ●: Lit up : Blinking

Error indication

System errors and similar warnings are indicated by the battery LED lamps through various lighting patterns.

Error indication type	Indication condition	Lighting pattern *1	Recovery
System error	Communication error with the bicycle system.		Make sure that the cable is not loose or improperly connected. If the situation does not improve, contact an agency.
Temperature protection	If the temperature exceeds the guaranteed operating range, the battery output is turned off.		Leave the battery in a cool place away from direct sunlight until the internal temperature of the battery decreases sufficiently. If the situation does not improve, contact an agency.
Security authentication error	This is displayed if a genuine drive unit is not connected. This is displayed if any of the cables are disconnected.		Connect a genuine battery and drive unit. Check the condition of the cables. If the situation does not improve, contact an agency.
Charging error	This is displayed if an error occurs during charging.		Remove the connector between the battery and charger, and press the power switch with only the battery connected. If an error appears with only the battery connected, contact an agency.
Battery malfunction	Electrical failure inside the battery.		Connect the charger to the battery and then remove the charger. Press the power switch with only the battery connected. If an error appears with only the battery connected, contact an agency.

*1 ●: Not lit ●: Lit up : Blinking

■ Turning the power ON / OFF

Automatic power off function

If the bicycle has not moved for over 10 minutes, the power will automatically turn off.

Turning the power ON and OFF via the cycle computer

<SC-E6010>

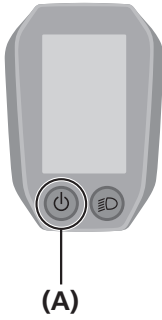

Hold down the power button (A) on the cycle computer for 2 seconds.

(A) Power button

NOTE

If built-in battery of cycle computer isn't charged sufficiently, the power will not turn on.
The built-in battery of the cycle computer is charged only when the cycle computer screen is on.

Turning the power ON and OFF via the battery

<BT-E6000/BT-E6001>

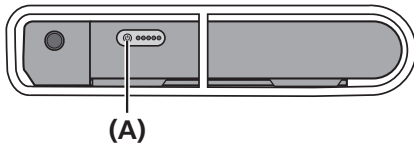

Press the power button (A) on the battery.

(A) Power button

NOTE

- When turning on the power, check that the battery is firmly attached to the holder.
- Power cannot be turned on while charging.
- Do not place your foot on the pedals when turning on. A system error may result.

<BT-E6010>

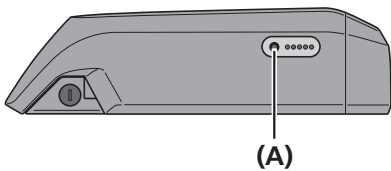

The LED lamps will light up indicating remaining battery capacity.

<BT-E8010>

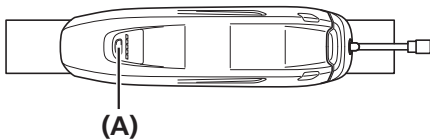

<BT-E8020>

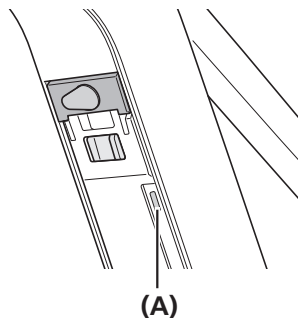

TECH TIPS

BT-E8010/BT-E8020 can be forced to power off by holding down the power button for 6 seconds.

Chapter4 CYCLE COMPUTER DISPLAY AND SETTING

CYCLE COMPUTER DISPLAY AND SETTING

The following explains the operation procedure for cases where the switch settings are set to the default values.

■ Names and functions of the parts of the assist switch

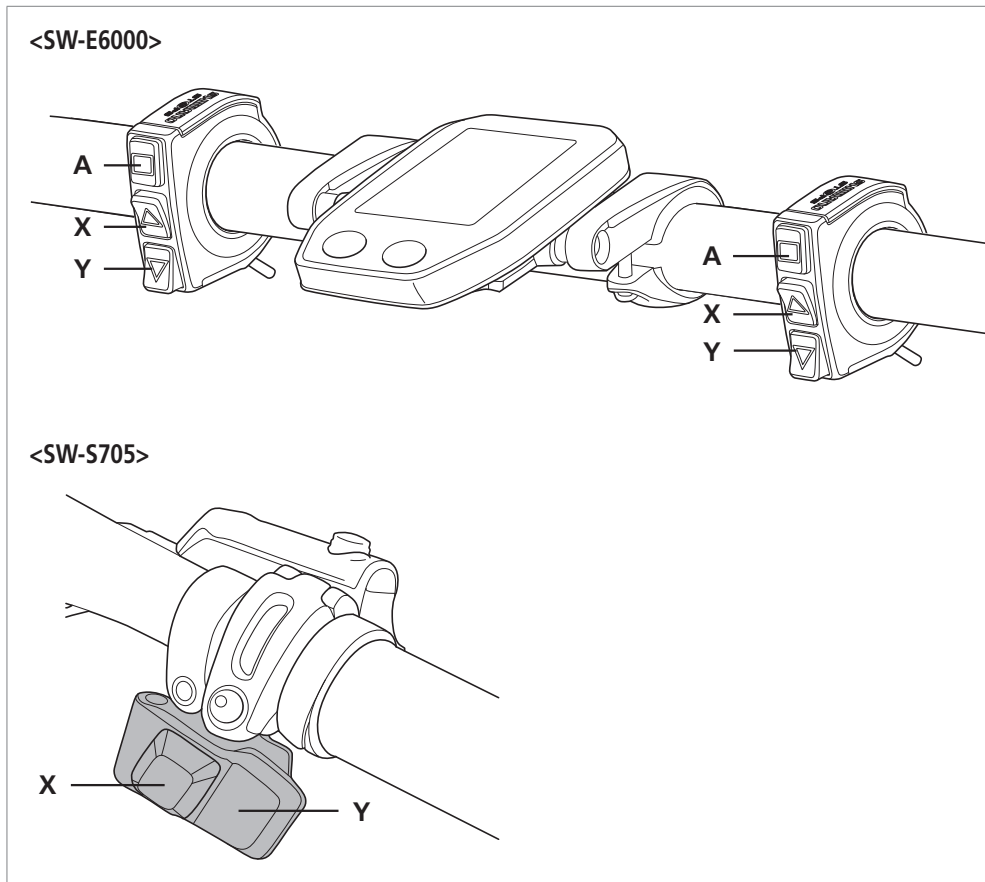

- A** Changing the cycle computer display
- X** **When switching assist modes:** the level of assistance becomes stronger
When shifting gears: pedaling becomes heavier
- Y** **When switching assist modes:** the level of assistance becomes weaker
When shifting gears: pedaling becomes lighter

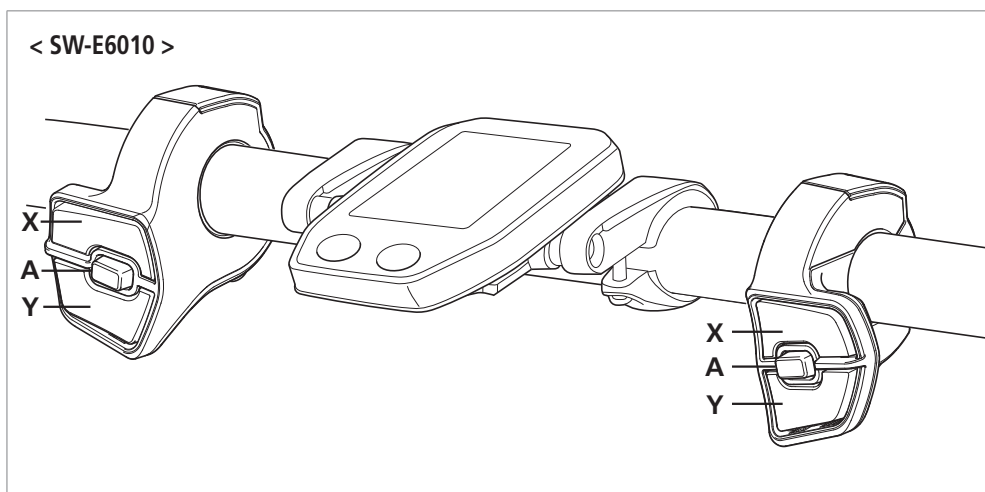

- A** Changing the cycle computer display
Switching between automatic and manual gear shifting
- X** **When switching assist modes:** the level of assistance becomes stronger
When shifting gears: pedaling becomes heavier
- Y** **When switching assist modes:** the level of assistance becomes weaker
When shifting gears: pedaling becomes lighter

■ Basic screen display of the cycle computer

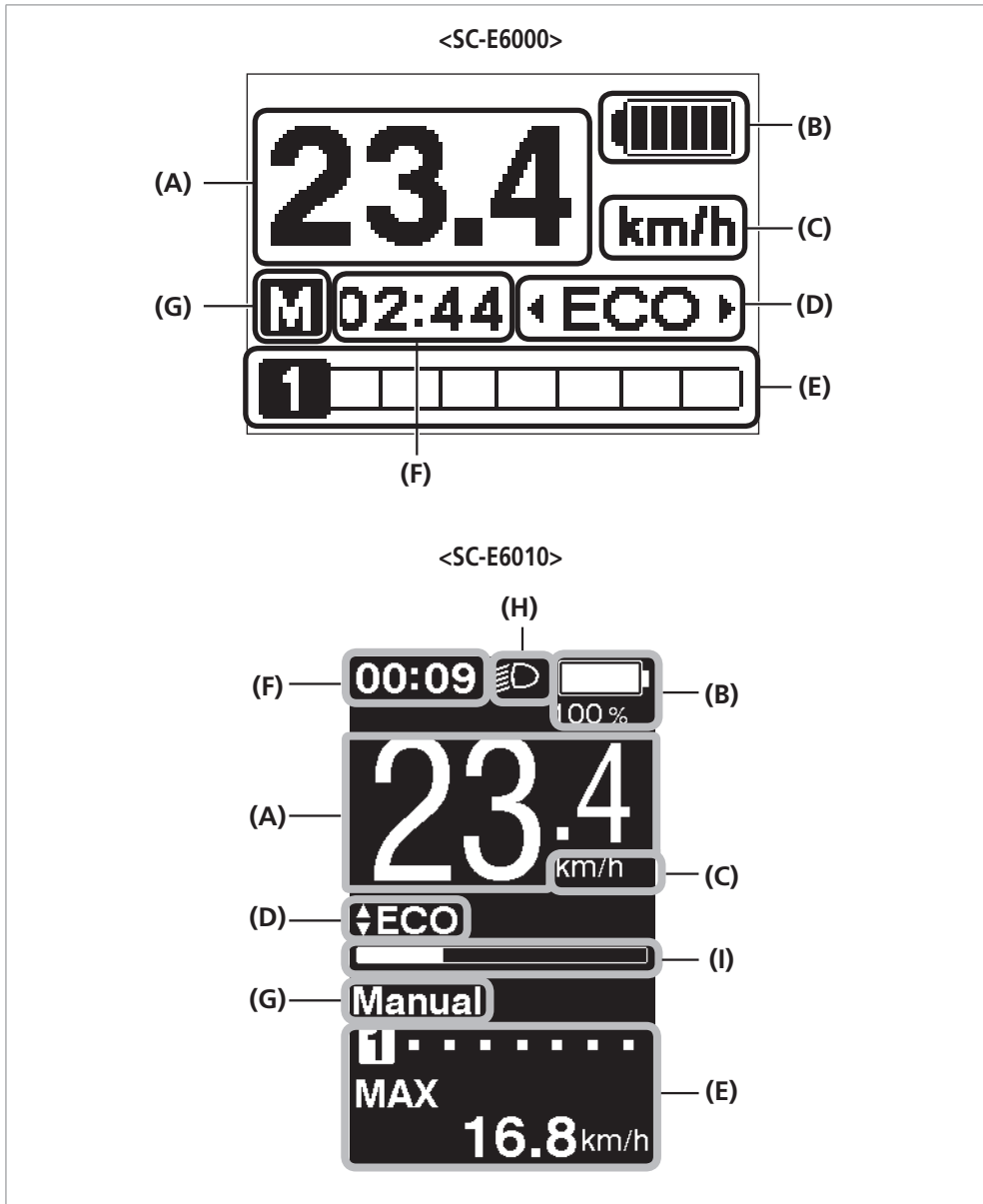

- (A) Current speed**
Displays the current speed.
- (B) Battery level indicator**
Displays the current battery level.
- (C) Speed unit display**
The display can be switched between km/h and mph.
- (D) Assist mode**
Displays the current assist mode.
- (E) Gear position and traveling data display**
Displays the currently set gear position or the traveling data. Operate the assist switch to change the display for SC-E6000 from the gear position display to the traveling data display.
- (F) Current time**
Displays the current time.
- (G) Gear shifting mode**
The current gear shifting mode is displayed as following.
SC-E6000: [A] (Auto)/[M] (Manual)
SC-E6010: [Auto]/[Manual]
- (H) Light icon**
Indicates that the battery-powered light is on.
- (I) Assist gauge**
Displays the assistance.

▶▶ Basic screen display of the cycle computer

B

<SC-E6000>

Display	Battery level
	100 - 81%
	80 - 61%
	60 - 41%
	40 - 21%
	20 - 1%
	0%

<SC-E6010>

Display	Battery level
	100%
	0%

You can check the battery level on the cycle computer while riding.

(B) Battery level indicator



When the traveling data display **(E)** is set to [RANGE], the battery level is not displayed.

Basic screen display of the cycle computer

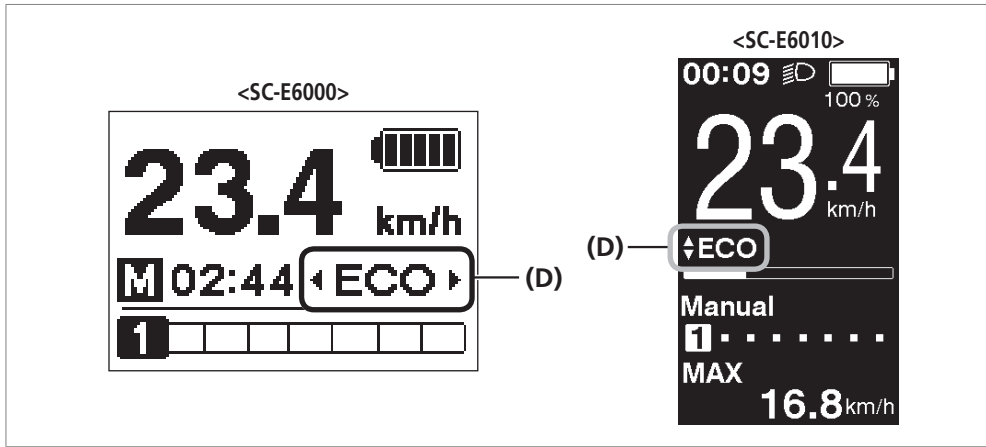

(D) Changing the assist mode display

Basic screen display of the cycle computer

< SW-E6000 >

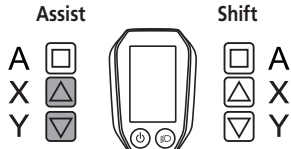

< SW-E6010 >

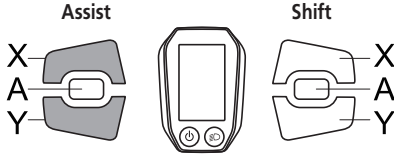

Display the current assist mode.
Press Assist-X or Assist-Y on the assist switch to switch assist modes.

< SW-E6000 >

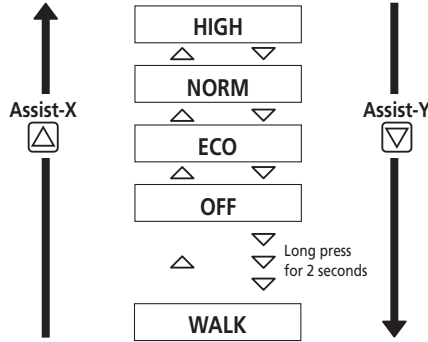

< SW-E6010 >

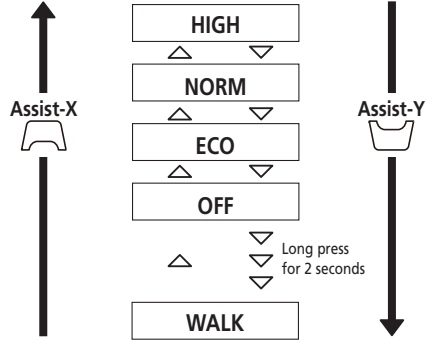

< SW-E6000 >

< Walk assist mode >



When the speed indicator is "0", pressing the Assist-Y button for 2 seconds switches to the walk assist mode.

Press Assist-X to switch the mode to [OFF].

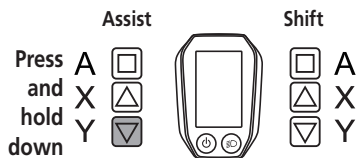

When [WALK] is displayed, press and hold down Assist-Y on the assist switch to start the walk assist function. Assist-Y stops the walk assist function, or pressing Assist-X can stop the walk assist function.

<SC-E6000>

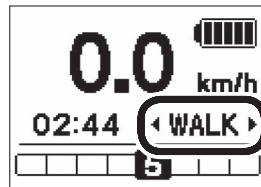
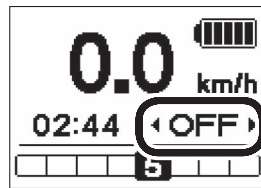

<SC-E6010>



NOTE

- The Walk assist mode function may not be able to be used in certain regions.
- When [WALK] is displayed, the mode changes to [OFF] if Assist-Y on the assist switch is not operated for 1 minute or longer.

TECH TIPS

- If the bicycle does not move after the walk assist function turns on, the function automatically stops. To restart the walk assist function, release the assist switch and press and hold down Assist-Y again.
- The walk assist function can operate at a maximum of 6 km/h.
- The assistance level and speed vary with the gear position.

Basic screen display of the cycle computer

D

< SW-E6010 >

< Walk assist mode >



When the speed indicator is "0", pressing the Assist-Y button for 2 seconds switches to the walk assist mode. Press Assist-X to switch the mode to [OFF].



When [WALK] is displayed, press and hold down Assist-Y on the assist switch to start the walk assist function. Assist-Y stops the walk assist function, or pressing Assist-X can stop the walk assist function.

<SC-E6000>

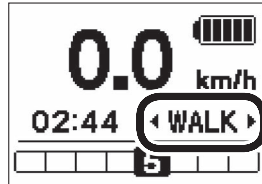
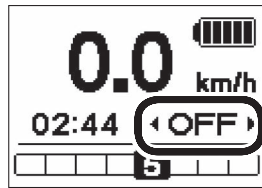

<SC-E6010>



NOTE

- The Walk assist mode function may not be able to be used in certain regions.
- When [WALK] is displayed, the mode changes to [OFF] if Assist-Y on the assist switch is not operated for 1 minute or longer.

TECH TIPS

- If the bicycle does not move after the walk assist function turns on, the function automatically stops. To restart the walk assist function, release the assist switch and press and hold down Assist-Y again.
- The walk assist function can operate at a maximum of 6 km/h.
- The assistance level and speed vary with the gear position.

Basic screen display of the cycle computer

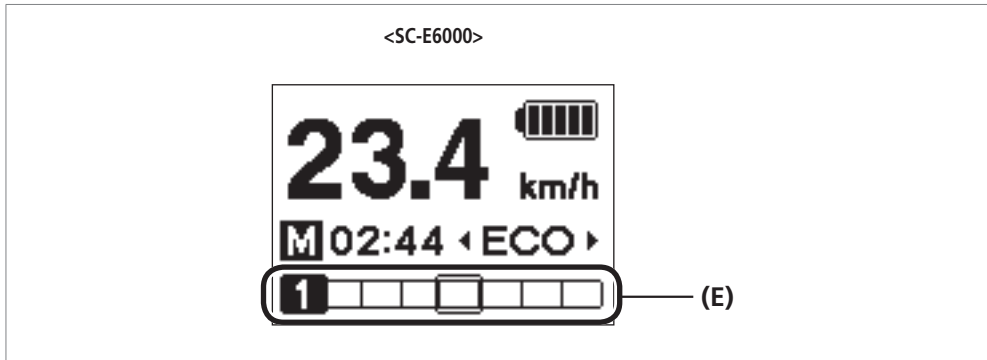

(E) Gear position and traveling data display

NOTE

The Walk assist mode function may not be able to be used in certain regions.

< SW-E6000 >

Assist Shift

A [Square] [Square] A

X [Up] [Up] X

Y [Down] [Down] Y

< SW-E6010 >

Assist Shift

X [Square] [Square] X

A [Up] [Up] A

Y [Down] [Down] Y

Displays the sprocket position or traveling data.
The type of traveling data displayed changes each time you tap Assist-A.

[Gear Bar] 6 > <DST 109.7 km >

△ <MAX 16.8 km/h > <ODO 11097 km >

△ <AVG 16.8 km/h > <RANGE 107 km >

△ <TIME 143:29 > < RANGE >

HIGH	61 km
NORM	77 km
ECO	97 km

Display	Details								
[Gear Bar] 6	Gear *5 (displayed only when motor unit is connected.)								
[Gear Bar] 1	Start gear *4 (when setting start mode)								
<DST 109.7 km >	Traveling distance								
<ODO 11097 km >	Cumulative distance								
<RANGE 107 km >	Maximum traveling distance*1, 3								
<table border="1"> <tr><td colspan="2">RANGE</td></tr> <tr><td>HIGH</td><td>61 km</td></tr> <tr><td>NORM</td><td>77 km</td></tr> <tr><td>ECO</td><td>97 km</td></tr> </table>	RANGE		HIGH	61 km	NORM	77 km	ECO	97 km	Maximum traveling distance (optional)*2
RANGE									
HIGH	61 km								
NORM	77 km								
ECO	97 km								
<TIME 143:29 >	Traveling time (optional)*2								
<AVG 16.8 km/h >	Average speed (optional)*2								
<MAX 16.8 km/h >	Maximum speed (optional)*2								

TECH TIPS

- * 1 When [RANGE] is displayed, the battery level and walk assist mode are not displayed. The traveling range should be used as a reference only.
- * 2 Optional item: You can configure the display settings in E-TUBE PROJECT. For details, refer to "Connection and communication with the PC"-"Settings customizable in E-TUBE PROJECT".
- * 3 When walk assistance is functioning, the on screen display [RANGE] changes to [RANGE ---].
- * 4 When start mode is functioning, the starting gear position during automatic shifting down function use is displayed.
- * 5 The gear position is only displayed when in the powered gear shifting mode.

Basic screen display of the cycle computer



- (G) Gear position
- (H) Traveling data display

NOTE

The Walk assist mode function may not be able to be used in certain regions.

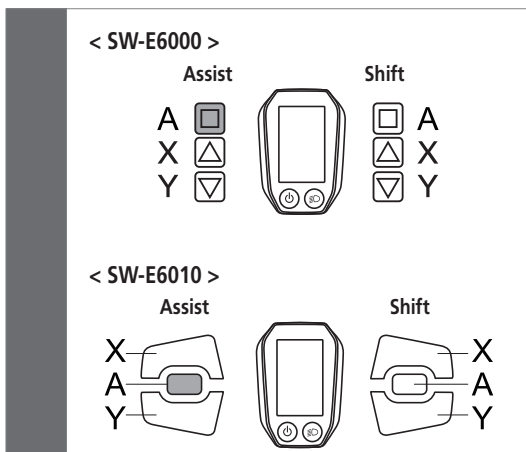

Displays traveling data.
The type of traveling data displayed changes each time you tap Assist-A.

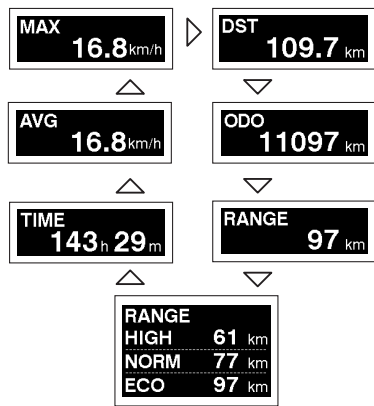

Display	Details
1	Gear *5 (displayed only when motor unit is connected.)
1	Start gear *4 (when setting start mode)
DST 109.7 km	Traveling distance
ODO 11097 km	Cumulative distance
RANGE 97 km	Maximum traveling distance*1, 3
RANGE HIGH 61 km NORM 77 km ECO 97 km	Maximum traveling distance (optional)*2
TIME 143h 29m	Traveling time (optional)*2
AVG 16.8 km/h	Average speed (optional)*2
MAX 16.8 km/h	Maximum speed (optional)*2

TECH TIPS

- * 1 When [RANGE] is displayed, the battery level and walk assist mode are not displayed. The traveling range should be used as a reference only.
- * 2 Optional item: You can configure the display settings in E-TUBE PROJECT. For details, refer to "Connection and communication with the PC"- "Settings customizable in E-TUBE PROJECT".
- * 3 When walk assistance is functioning, the on screen display [RANGE] changes to [RANGE ---].
- * 4 When start mode is functioning, the starting gear position during automatic shifting down function use is displayed.
- * 5 The gear position is only displayed when in the powered gear shifting mode.

Turning the battery-powered light on or off

<SC-E6000>

< SW-E6000 >

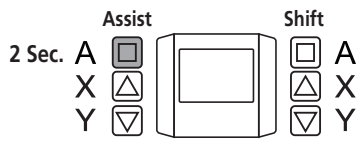

< SW-E6010 >

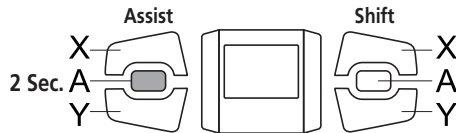

When the light is set in E-TUBE PROJECT, pressing the Assist-A for 2 seconds displays this information instead of the clock and assist mode. The light turns on and off each time it is displayed. It is displayed for about 2 seconds.

When the light is turned on

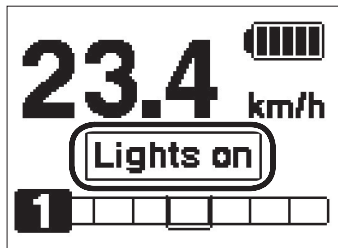

When the light is turned off

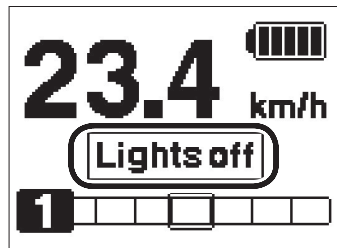

▶ Basic screen display of the cycle computer

<SC-E6010>

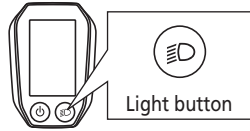

When a battery-powered light is connected, the light can be turned on by pressing the cycle computer's light button. When this is done, an icon indicating that the light is on appears on the screen. Press the light button again to turn the light off. The icon turns off from the display when the light is turned off.

* When [Backlight] is set to [MANUAL] while no battery-powered light is connected, the cycle computer's backlight turns on and off each time the light button is pressed. In this case, the icon indicating that the light is on is not displayed.

When the light is turned on



When the light is turned off



 TECH TIPS

The light turns off when the battery's power is turned off.
When the battery power is off, the light is off.

Switching the gear shifting mode

< SW-E6000 >

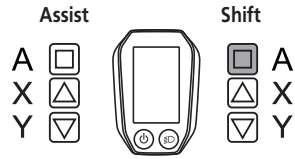

< SW-E6010 >

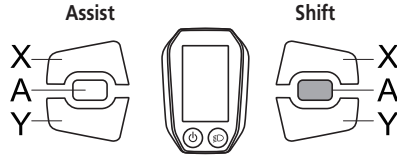

The gear shifting mode switches between auto and manual each time Shift-A is pressed with the basic screen displayed.

<SC-E6000>

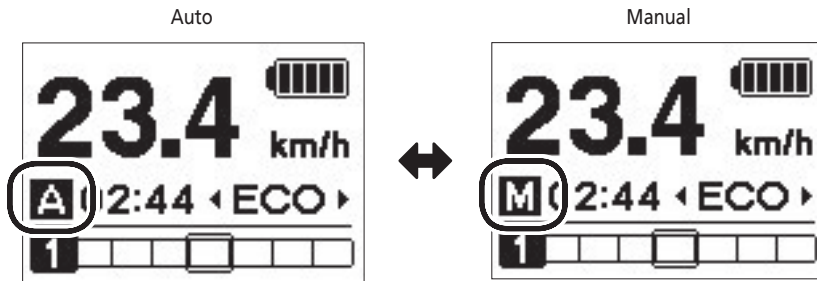

<SC-E6010>

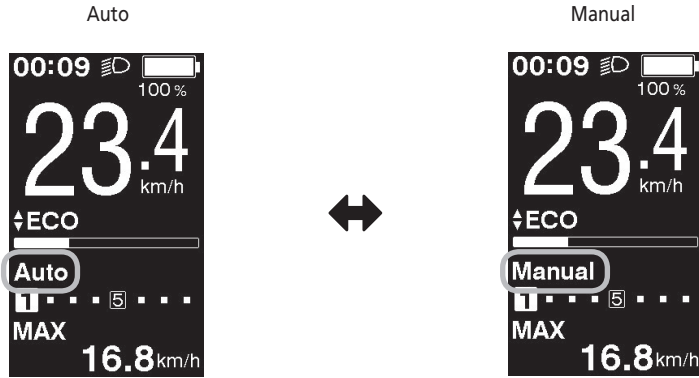

Clearing the traveling distance

The traveling distance can be cleared in the main screen. If a battery-powered light is connected and configured, clear the traveling distance (DST) as described under "Changing the settings" - "Clear".

* When using the SC-E6000, this function can only be used when no light is connected.

1

< SW-E6000 >



< SW-E6010 >

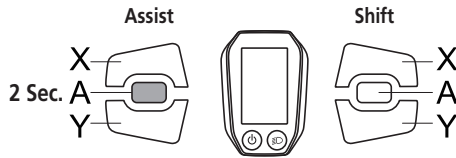

Change the traveling data display to DST and press the Assist-A for 2 seconds.

<SC-E6000>



<SC-E6010>



2

Release the button when the DST indication starts blinking. In this state, pressing the Assist-A again clears the traveling distance.

<SC-E6000>



<SC-E6010>



TECH TIPS

- If you do not operate the system for five seconds, the DST indication stops blinking and the display returns to the basic screen.
- When the traveling distance is cleared, TIME, AVG, and MAX are also cleared.

■ Changing the settings

Starting the setting menu

< SW-E6000 >

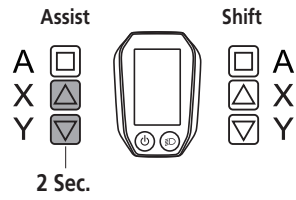

< SW-E6010 >

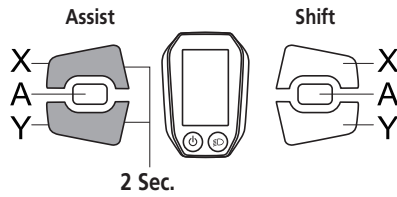

With the bicycle stopped, pressing both the Assist-X and Assist-Y at the same time for 2 seconds displays the setting screen.

1

<SC-E6000>



<SC-E6010>



Changing the settings

< SW-E6000 >

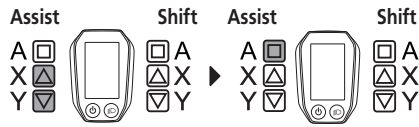

< SW-E6010 >

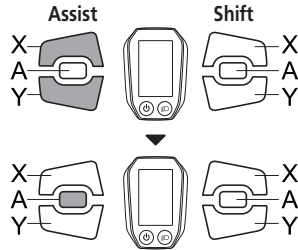

Press the Assist-X or Assist-Y to move the cursor to the item you want to configure. Pressing the Assist-A displays the setting screen for the item selected.

2

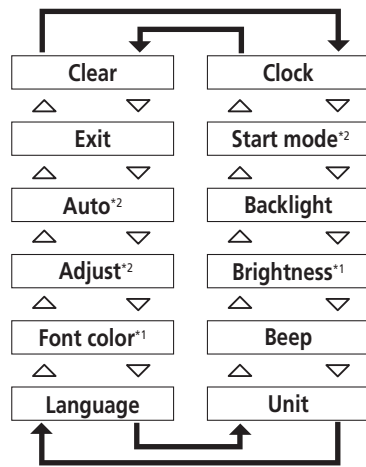

Settable items	Details
Clear	Clear settings
Clock	Clock setting
Start mode ^{*2}	Start mode setting
Backlight	Backlight setting
Brightness ^{*1}	Backlight brightness setting
Beep	Beep setting
Unit	Switching between km and mile
Language	Language setting
Font color ^{*1}	Font color setting
Adjust ^{*2}	Adjusting the electronic gear shifting unit
Auto ^{*2}	Adjusting the gear shifting timing
Exit	Return to the main screen

* 1: This menu is only for the SC-E6010.

* 2: This operation is only possible with electronic gear shifting.

Clear

Clear the traveling distance. Or return the display setting to default.

< SW-E6000 >

Assist

A □

X ▲

Y ▼



Shift

□ A

▲ X

▼ Y

< SW-E6010 >

Assist

X

A

Y



Shift

X

A

Y

1 Press the Assist-X or Assist-Y to move the cursor to the item you want to configure.

<SC-E6000>



<SC-E6010>



Item	Details
Exit	Return to the Setting menu screen
DST	Clearing the traveling distance
Default	Reset the SC display setting to default

Default value set in the SC display setting

Item	Default value
Backlight	ON
Beep	ON
Unit	km
Language	English
<SC-E6010> Brightness	3
<SC-E6010> Font color	White

▶▶ Changing the settings

< SW-E6000 >



< SW-E6010 >

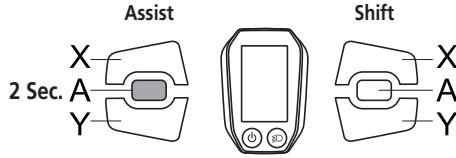

2

Pressing the Assist-A button enables the setting item indicate by the cursor and takes you back to the "Setting menu" screen.

<SC-E6000>



<SC-E6010>



 TECH TIPS

When the traveling distance is cleared, TIME, AVG, and MAX are also cleared.

Clock

Configure the clock setting.



Press Assist-X to increase the numbers.
Press Assist-Y to decrease the numbers.

1

< SW-E6000 >

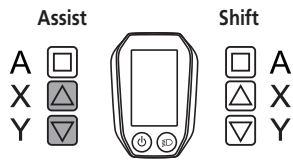

< SW-E6010 >

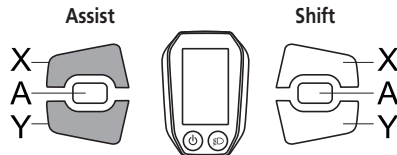

Press the Assist-X or Assist-Y to set the hour.

<SC-E6000>



<SC-E6010>



2

< SW-E6000 >

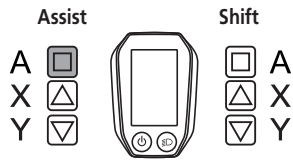

< SW-E6010 >

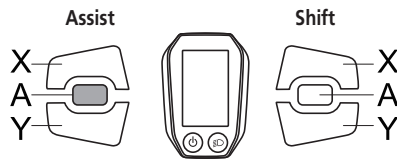

Pressing the Assist-A enables the set value and moves you to the minutes setting.

<SC-E6000>



<SC-E6010>

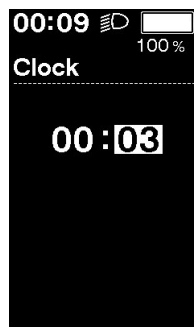

▶▶ Changing the settings

3

< SW-E6000 >

Assist

A 
 X 
 Y 





Shift

 A
 X
 Y

Press the Assist-X or Assist-Y to set the minutes.



< SW-E6010 >

Assist

X 
 A 
 Y 



Shift

X 
 A 
 Y 

4

< SW-E6000 >

Assist

A 
 X 
 Y 





Shift

 A
 X
 Y

Pressing the Assist-A enables the set value and takes you back to the "Setting menu" screen.



< SW-E6010 >

Assist

X 
 A 
 Y 



Shift

X 
 A 
 Y 



TECH TIPS

You can change the numbers quickly by holding down the Assist-X or Assist-Y.

Start mode

Set the start gear when using start mode function.

< SW-E6000 >

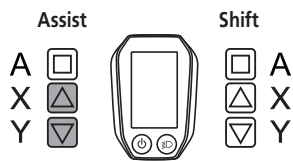

< SW-E6010 >

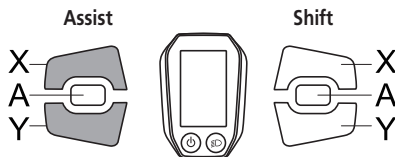

1

Press the Assist-X or Assist-Y to move the cursor to the item you want to configure.

<SC-E6000>



<SC-E6010>



Item	Details
OFF	No setting
2	2-speed
3	3-speed
4	4-speed
5	5-speed

NOTE

When in a lower gear than the one set while stopped, the gear will not shift up automatically.



Even with auto gear shifting enabled, when the bicycle is stopped, gear position will return to the start mode start gear that was set.

2

< SW-E6000 >

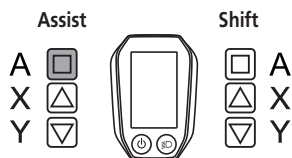

< SW-E6010 >

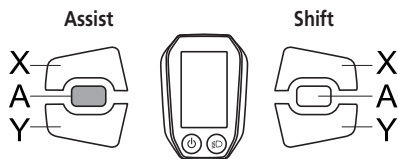

Pressing the Assist-A button enables the set value at the cursor position and takes you back to the "Setting menu" screen.

Backlight

Configure the display backlight setting.

Item	Details
ON	Keep light always on
OFF	Keep light always off
MANUAL	Turns on and off in conjunction with the battery-powered light

1

< SW-E6000 >

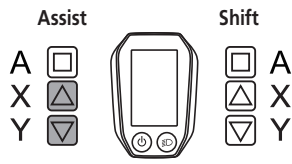

< SW-E6010 >

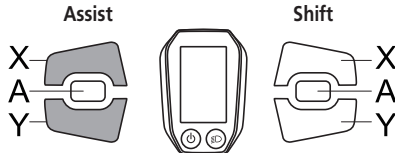

Press the Assist-X or Assist-Y to move the cursor to the item you want to configure.

<SC-E6000>



<SC-E6010>

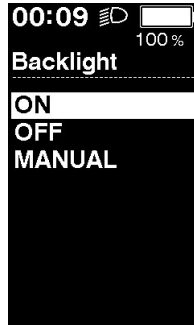

2

< SW-E6000 >

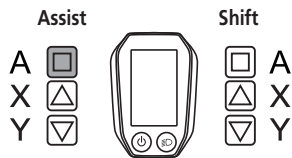

< SW-E6010 >

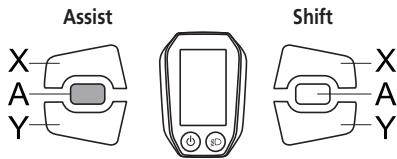

Press the Assist-X or Assist-Y to move the cursor to the item you want to configure.

Pressing the Assist-A button enables the setting item indicated by the cursor and takes you back to the "Setting menu" screen.

Brightness <SC-E6010>

The brightness of the backlight can be adjusted as needed.

< SW-E6000 >

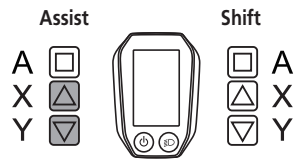

< SW-E6010 >

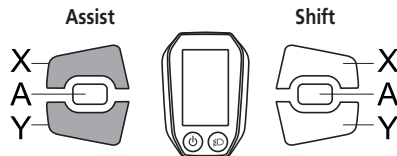

1

Press Assist-X or Assist-Y to adjust the brightness.

- Brightness can be adjusted to one of 5 levels.

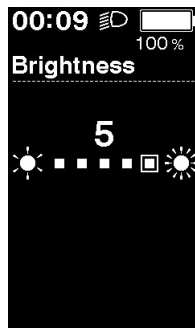

2

< SW-E6000 >

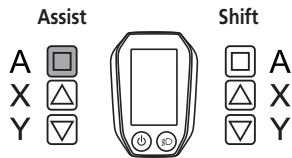

< SW-E6010 >

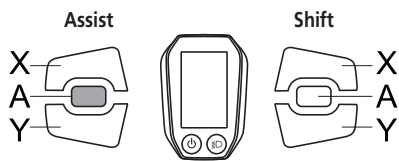

Pressing the Assist-A button enables the set value at the cursor position and takes you back to the "Setting menu" screen.

Beep

The beep sound can be turned on/off.

< SW-E6000 >

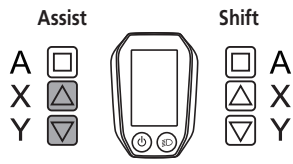

< SW-E6010 >

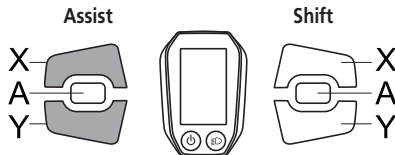

1

Press the Assist-X or Assist-Y to move the cursor to the item you want to configure.

<SC-E6000>



<SC-E6010>



Item	Details
ON	Enable beeps
OFF	Disable beeps



Even when [Beep] is set to [OFF], a beep will sound when there is a misoperation, system error, etc.

2

< SW-E6000 >

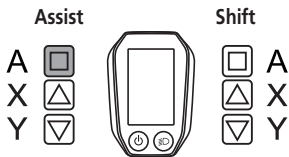

< SW-E6010 >

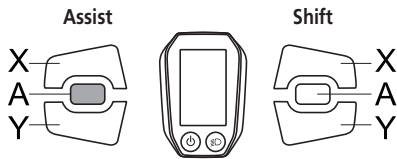

Pressing the Assist-A button enables the setting item indicated by the cursor and takes you back to the "Setting menu" screen.

Unit

Distance units (km/miles) can be switched.

Item	Details
km	Displayed in km
mile	Displayed in miles

1

< SW-E6000 >

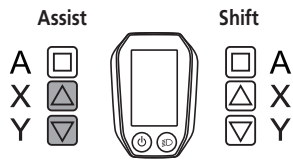

< SW-E6010 >

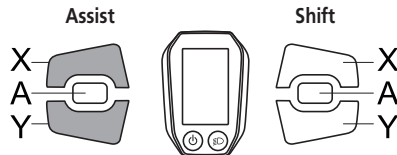

Press the Assist-X or Assist-Y to move the cursor to the item you want to configure.

<SC-E6000>



<SC-E6010>



2

< SW-E6000 >

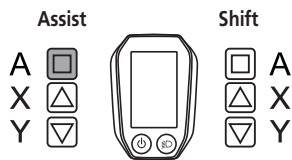

< SW-E6010 >

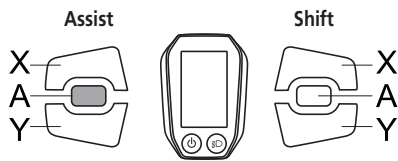

Pressing the Assist-A button enables the setting item indicated by the cursor and takes you back to the "Setting menu" screen.

Language

Configure the language setting.

Language
English
French
German
Dutch
Italian
Spanish

1

< SW-E6000 >

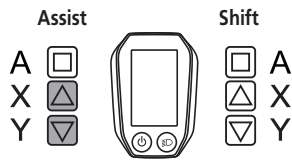

< SW-E6010 >

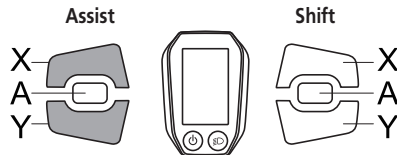

Press the Assist-X or Assist-Y to move the cursor to the item you want to configure.

<SC-E6000>



<SC-E6010>



2

< SW-E6000 >

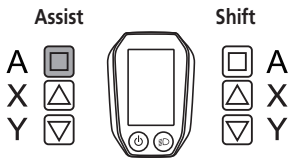

< SW-E6010 >

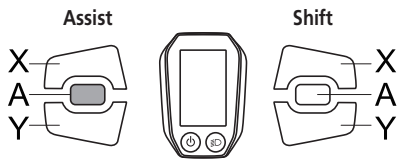

Pressing the Assist-A button enables the setting item indicated by the cursor and takes you back to the "Setting menu" screen.

Font color <SC-E6010>

The font color can be changed.

1

Press the Assist-X or Assist-Y to move the cursor to the item you want to configure.

< SW-E6000 >

Assist

A 

X 

Y 



Shift

A 

X 

Y 

< SW-E6010 >

Assist

X 

A 

Y 



Shift

X 

A 

Y 

<White>



<Black>

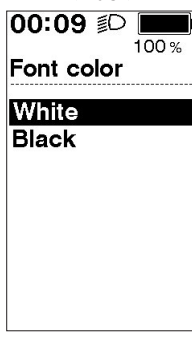



Settable items
White
Black

2

< SW-E6000 >

Assist

A 

X 

Y 



Shift

A 

X 

Y 

< SW-E6010 >

Assist

X 

A 

Y 



Shift

X 

A 

Y 

Pressing the Assist-A button enables the setting item indicated by the cursor and takes you back to the "Setting menu" screen.

Adjust

Gear shifting adjustment is performed with the electronic gear shifting unit.

⚠ CAUTION

- Improperly large adjustment may cause free spinning of the pedals during pedaling, resulting in an accidental fall.
- Perform adjustment only when gear shifting feels unusual. Under normal conditions, performing unnecessary adjustment may worsen gear shifting performance.

Open the Adjust screen and check whether the adjustment value is set to [0].

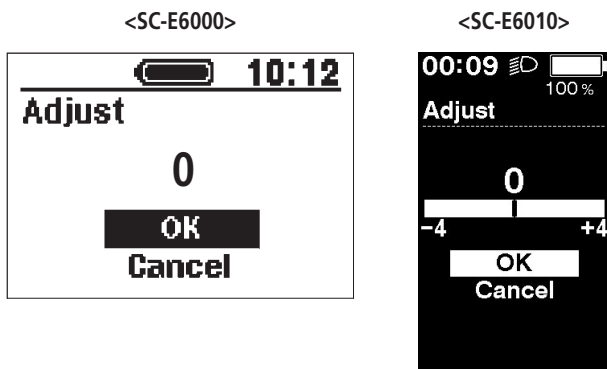

📖 TECH TIPS

- Gear shifting adjustment can only be performed when an electronic internal geared hub is connected.
- The settings have a range of -4 to 4.



▶▶ Changing the settings



If the adjustment value is [0]



1

< SW-E6000 >

Assist Shift



A    A



X    X



Y    Y

< SW-E6010 >

Assist Shift

X    X

A    A

Y    Y

Press Shift-X or Shift-Y to adjust the adjustment value up or down by 1 speed.

<SC-E6000>



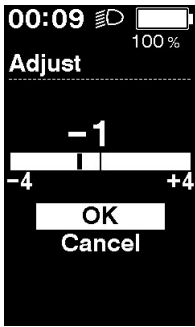

<SC-E6010>









2

< SW-E6000 >

Assist Shift



A    A



X    X



Y    Y

< SW-E6010 >

Assist Shift

X    X

A    A

Y    Y

Press Assist-A.

Select [OK], then perform an actual gear shift to check whether the condition has improved.

▶▶ Changing the settings

3

The condition has improved

Adjust the adjustment value by 1 speed in the same direction and check the gear shifting operation again.

Repeat these steps until any noise or unusual feeling disappears.

<SC-E6000>

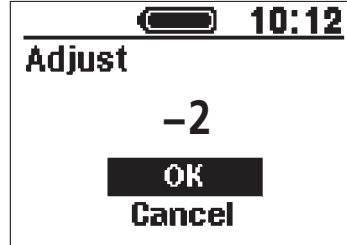
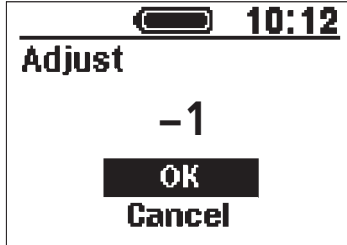

<SC-E6010>

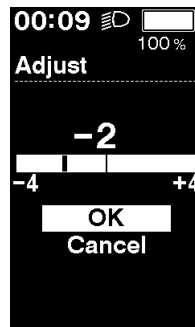
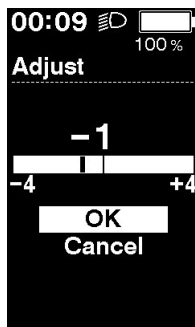

▶ Changing the settings

No apparent change

Adjust the adjustment value by 1 speed in the same direction and check the gear shifting operation again.

If the condition has improved, see "The condition has improved" to continue.

If the condition has worsened, see "The condition has worsened" to continue.

3

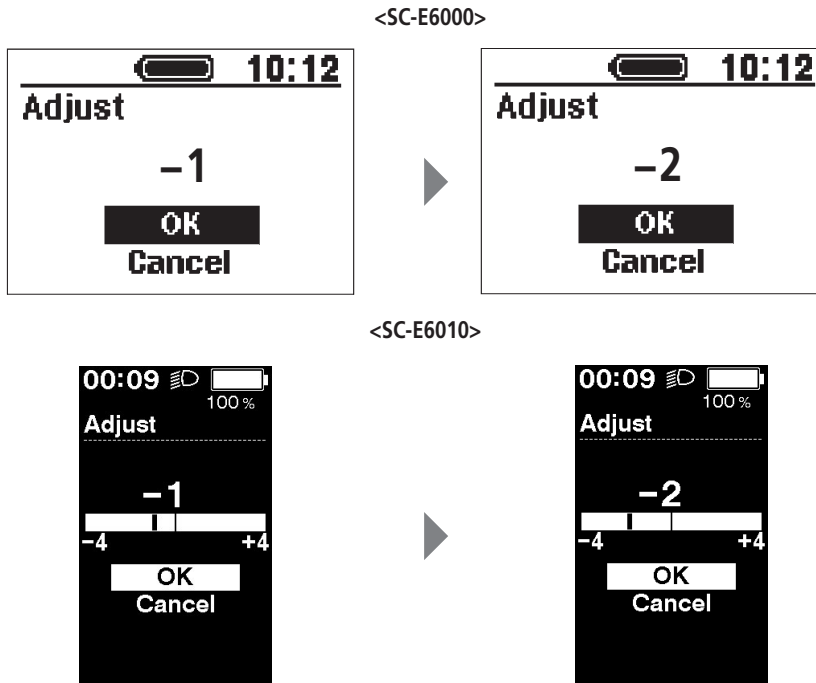

The condition has worsened

Adjust the adjustment value by 2 speeds in the opposite direction and check the gear shifting operation again.

Then, adjust the value by 1 speed in the same direction and check until any noise or unusual feeling is gone.

3

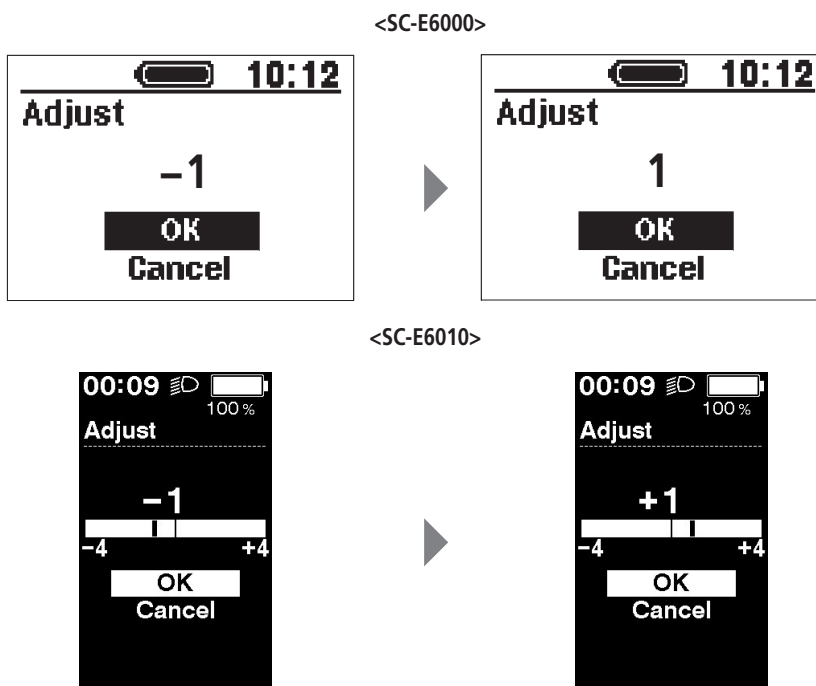

▶▶ Changing the settings

4 Finally, go for an actual ride and check for any noise or unusual feeling.

If the adjustment value is not [0]

< SW-E6000 >

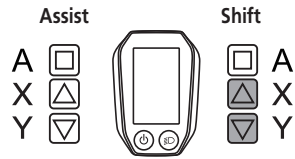

< SW-E6010 >

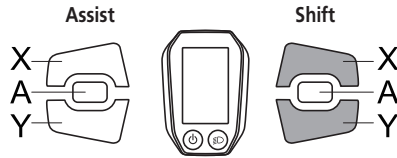

Press Shift-X or Shift-Y to and revert the adjustment value to [0].

1

<SC-E6000>

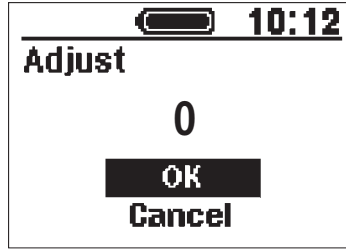
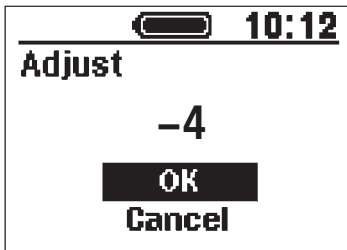

<SC-E6010>

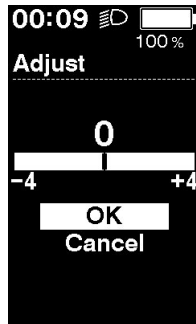
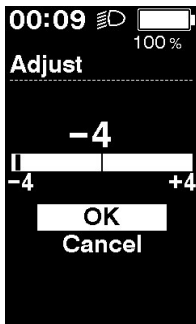

▶▶ Changing the settings

2

< SW-E6000 >

Assist



Shift



< SW-E6010 >

Assist

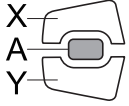

Shift

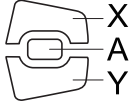

Press Assist-A.

Select [OK], then perform an actual gear shift to check whether the condition has improved.

3

Finally, go for an actual ride and check for any noise or unusual feeling.

Auto

When the gear shifting mode is set to auto, the timing at which gears shift can be adjusted.

< SW-E6000 >

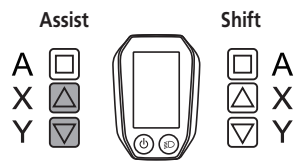

< SW-E6010 >

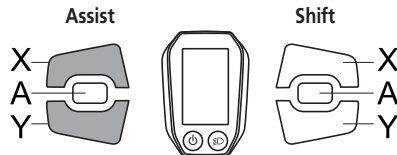

Press Assist-X or Assist-Y to adjust the values.

- Pressing Assist-X and adjusting the value upward adjusts shift timing to make pedaling easier.
- Pressing Assist-Y and adjusting the value downward adjusts shift timing to make pedaling harder.

1

<SC-E6000>



<SC-E6010>

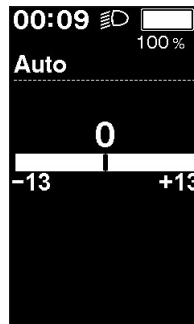

< SW-E6000 >

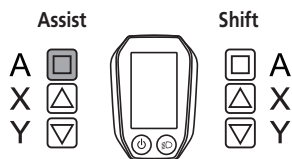

< SW-E6010 >

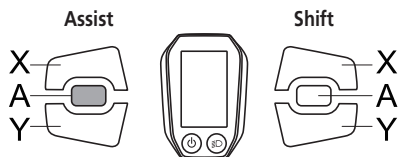

Pressing Assist-A enables the adjusted value and takes you back to the "Setting menu".

2

▶▶ Changing the settings

NOTE

- For SC-S705, pressing the shift up and shift down switches at the same time allows toggling between auto and manual gear shifting modes but gear shifting timing cannot be adjusted.

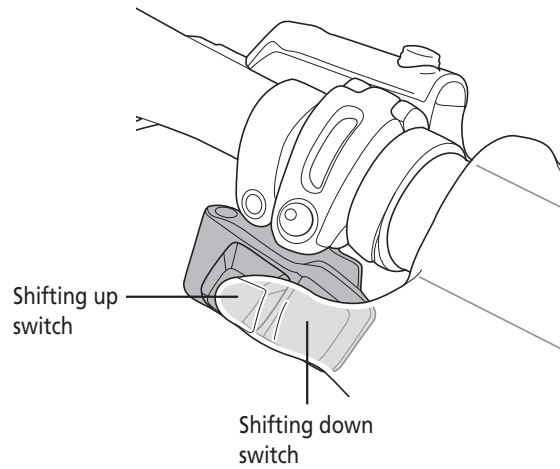
**Exit**

Close the setting menu and returns to the basic screen.

1 Press the Assist-X or Assist-Y to move the cursor to [Exit].

2 Pressing the Assist-A exits the setting menu and takes you back to the basic screen.

Update confirmation window for the drive unit settings backup data

The cycle computer has a function to automatically back up drive unit settings.

In the following cases, when the cycle computer power is turned on, a window confirming whether to update the backup data is displayed:

- Reinstalling the cycle computer on a bicycle with different settings
- If the drive unit settings have been changed via E-TUBE PROJECT

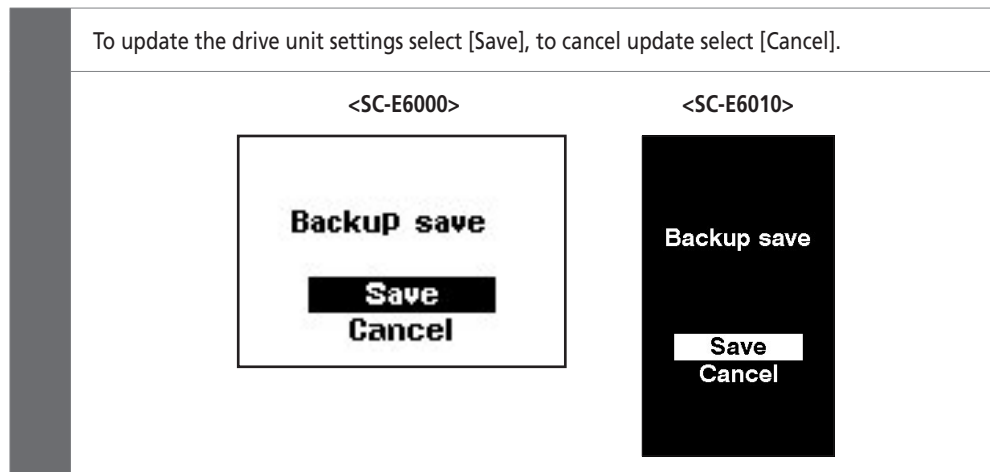



If the settings cannot be accessed due to a drive unit malfunction, they can be accessed using E-TUBE PROJECT.

■ Error messages on the cycle computer

Warnings

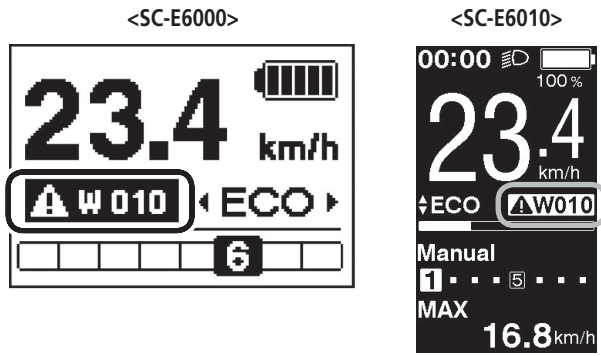
This disappears if the error is fixed.
For the SC-E6000, a message is displayed instead of the clock.



Code	Display preconditions	Operational restrictions while warning is displayed	Remedy
W031	The chain tension may not yet be adjusted or the crank may not be installed in the proper position.	The assist functions do not work. (However, electronic gear shifting will still function.)	<p>Contact your place of purchase or a local bicycle dealer for their assistance.</p> <p style="text-align: center;"><SC-E6010></p> <div style="text-align: center; background-color: black; color: white; padding: 10px;"> <p>W031</p> <p></p> <p>Yes No</p> </div>

List of warnings

Code	Display preconditions	Operational restrictions while warning is displayed	Remedy
W010	The temperature of the drive unit is high.	The level of assistance may decrease.	Stop using the assist function until the temperature of the drive unit drops. If the situation does not improve, consult an agency.
W011	The traveling speed cannot be detected.	The maximum speed up to which power assistance is provided may decrease. (Power assistance is provided up to 25 km/h (20 mph) in top gear.)	Check the following: <ul style="list-style-type: none"> • Whether the speed sensor is installed in the correct position. • Whether the magnet included with the disc brake rotor has not come off. Refer to the Disc Brake section of General Operations for steps on reattaching the magnet. If the situation does not improve, consult an agency.
W012	The crank may be installed in the wrong direction.	-	Re-install the crank in the specified direction, then turn the power back on.
W030	Two or more assist switches are connected to the system.	Gear shifting is not available for electronic gear shifting derailleurs.	Change the assist switch to the gear shifting switch, or connect only one assist switch and turn the power ON again. If the situation does not improve, consult an agency.
-	A communication error between the drive unit and the motor unit was detected.	Gear shifting is not available for electronic gear shifting derailleurs.	Check that the cable is properly connected between the drive unit and the motor unit. If the situation does not improve, consult an agency.

Errors

If an error message is displayed on the entire screen, follow one of the procedures below to reset the display.

- Press the power switch of the battery.
- Remove the battery from the mount.

<SC-E6000>

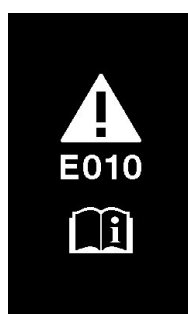

<SC-E6010>

**NOTE**

If resetting does not solve the problem or the same problem occurs frequently, consult an agency.

List of errors

Code	Display preconditions	Operational restriction when an error is being displayed	Remedy
E010	A system error was detected.	Power assistance is not provided during riding.	Press the power switch of the battery to turn on the power again. If the situation does not improve, consult an agency.
E012	The initialization of the torque sensor failed.	Power assistance is not provided during riding.	With your foot off the pedal, press the power switch of the battery to turn on the power again. Refer to "Measuring and adjusting the chain tension", then check that the chain tension is appropriate. If the situation does not improve, consult an agency.
E013	An error was detected in the drive unit's firmware.	Power assistance is not provided during riding.	Check whether the speed sensor is installed in the correct position. If the speed sensor is not in the correct position, the error will be resolved by installing it in the correct position and riding the bicycle for a little while. If the error is still not resolved, consult an agency.
E014	The speed sensor may be installed in the wrong position.	Power assistance is not provided during riding.	Check whether the speed sensor is installed in the correct position. If the speed sensor is not in the correct position, the error will be resolved by installing it in the correct position and riding the bicycle for a little while. If the error is still not resolved, consult an agency.
E020	A communication error between the battery and drive unit was detected.	Power assistance is not provided during riding.	Check that the cable between the drive unit and battery is properly connected. If the situation does not improve, consult an agency.
E021	Battery connected to drive unit conforms with system standards but is not supported.	Power assistance is not provided during riding.	Consult an agency.
E022	Battery connected to drive unit does not conform with system standards.	Power assistance is not provided during riding.	Consult an agency.
E030	A setting error was detected.	Power assistance is not provided during riding.	Press the power switch of the battery to turn on the power again. If the situation still does not improve, consult an agency.
E031	The chain tension may not yet be adjusted or the crank may not be installed in the proper position.	The assist functions do not work. (However, electronic gear shifting will still function.)	Consult an agency.
E033	The current firmware is not compatible with this system.	Power assistance is not provided during riding.	Connect to E-TUBE PROJECT, then update the firmware for all units to the latest version.
E043	The cycle computer's firmware may be partially corrupt.	Power assistance is not provided during riding.	Consult an agency.

Chapter5 CONNECTION AND COMMUNICATION WITH PC

CONNECTION AND COMMUNICATION WITH PC

You can connect the bicycle (system or components) to a PC via a PC linkage device to carry out tasks such as customizing single components or the whole system and updating their firmware.

You need E-TUBE PROJECT to configure SHIMANO STEPS and update firmware. Download E-TUBE PROJECT from our support website (<http://e-tubeproject.shimano.com>). For information on how to install E-TUBE PROJECT, check the E-TUBE support website. For information on how to use E-TUBE PROJECT on your PC, refer to the help manual for E-TUBE PROJECT.

NOTE

- You need SM-PCE1 and SM-JC40/JC41 to connect SHIMANO STEPS to a PC. They are not required if there is an available port.
- Firmware is subject to change without notice.
- PC connection and communication are not possible during charging.
- Do not connect to E-TUBE PROJECT while the battery is being charged.

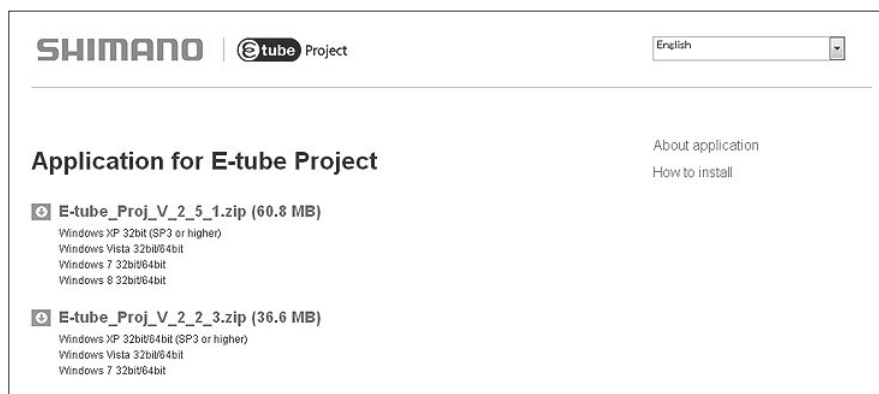

■ Drive unit setting backup function for the cycle computer

To check the drive unit settings backed up to the cycle computer, export the PDF report from the E-TUBE PROJECT [Unit log acquisition] menu. When exchanging the drive unit, send the report along with the unit to your place of purchase or a local bicycle dealer.

■ Settings customizable in E-TUBE PROJECT

Switch function setting		Changes the functions to assign to switches A, X, and Y of SW-E6000, SW-E6010 or switch X and Y of SW-S705. Functions that can be assigned vary depending on the type of switch. <ul style="list-style-type: none"> • SW-E6000/SW-E6010: The same function cannot be assigned to different switches. • SW-S705: The same function can be assigned to different switches.
Switch mode setting		Sets SW-E6000/SW-E6010 to be used for either assist mode switching or gear shifting.
Drive unit setting	Light connection	Sets whether to use a light.
	Start mode	Switches the start mode on or off. You can change gear position when on is selected.
	Automatic gear shifting	Auto gear shifting can be enabled or disabled. The timing for gear shifting can also be adjusted.
Display monitor settings	Display units	Switches the display unit between km and mile.
	Time setting	Sets the time.
	Backlight setting	Switches the backlight of the cycle computer on or off.
	Backlight brightness setting (SC-E6010)	The backlight's brightness can be adjusted.
	Beep setting	Switches the beep sound on or off.
	Display language	You can choose from English, French, German, Dutch, Spanish, and Italian.
	Font color setting (SC-E6010)	The font color can be set to white or black.
	Traveling time	Switches the traveling time indication on or off.
	Average speed	Switches the average speed indication on or off.
	Maximum speed	Switches the maximum speed indication on or off.
Range overview	Switches the traveling range list indication on or off.	
Motor unit gear setting		Switches MU-S705 between the 8-speed and 11-speed setting.
Other functions		<ul style="list-style-type: none"> • Error check • Update firmware • Preset • Unit log acquisition • Customizing the motor unit (MU-S705) <p>* For details, download E-TUBE PROJECT and refer to the manual provided.</p>

NOTE

When the SC-E6010 firmware is updated, the time set for the cycle computer is reset to match the computer's clock.

■ Connecting to the PC

When connecting only individual units

Connect SM-PCE1 to the connector of each unit.

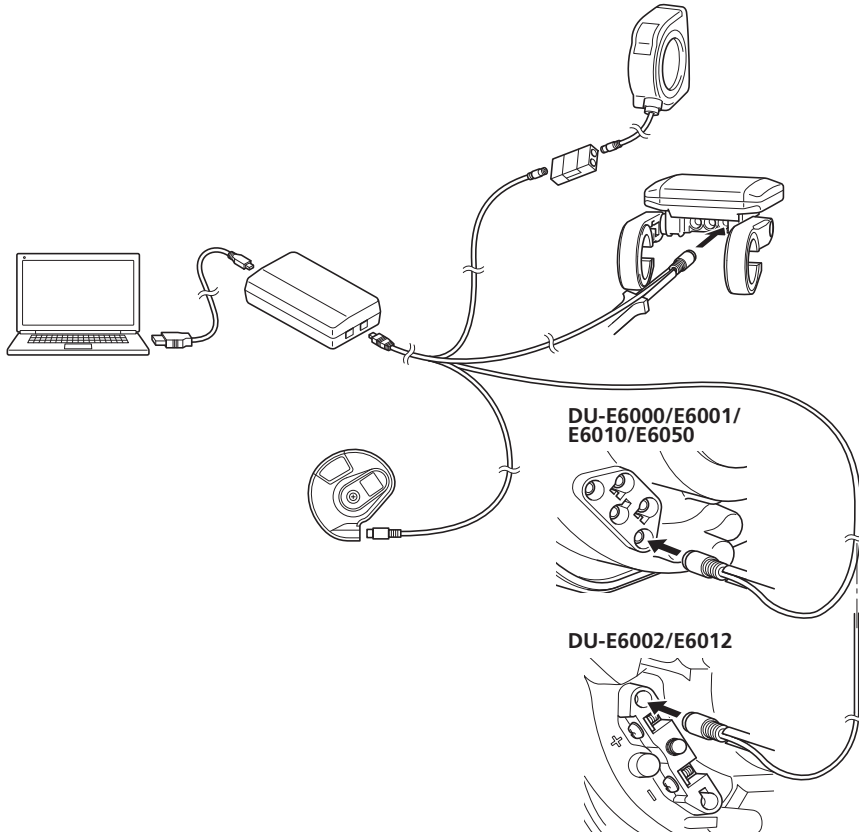

NOTE

When connecting SW-E6000/SW-E6010, you need SM-JC40/41.

Connecting to the bicycle

< When the cycle computer has an available port >

Connect SM-PCE1 to an available port of the cycle computer.

1

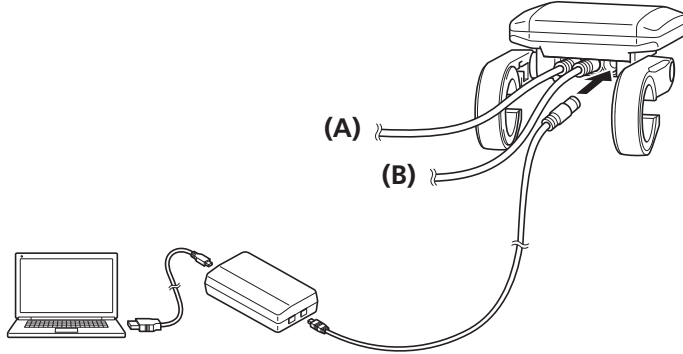

- (A) Assist switch
- (B) Drive Unit

< When the cycle computer has no available port >

First, connect SM-JC40/JC41 to SM-PCE1.
Then, disconnect EW-SD50 from the center port of the cycle computer and connect it to SM-JC40/JC41.

1

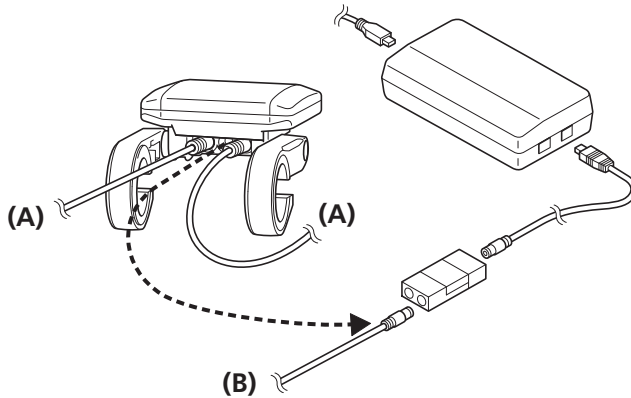

- (A) Assist switch
- (B) Drive Unit

Connect EW-SD50 to the available port of SM-JC40/JC41 and the center port of the cycle computer.

2

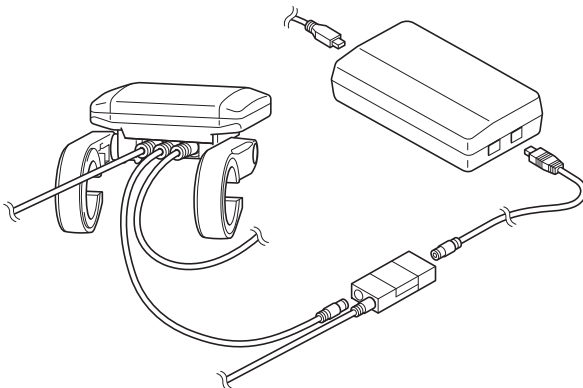

Chapter6 MAINTENANCE

MAINTENANCE

■ Replacing the front chainring

1 Perform replacement with the chain installed to the rear wheel. Remove the crank arm cap, then remove the crank mounting bolt with a 14 mm socket wrench. After that, remove the right side crank using TL-FC11.

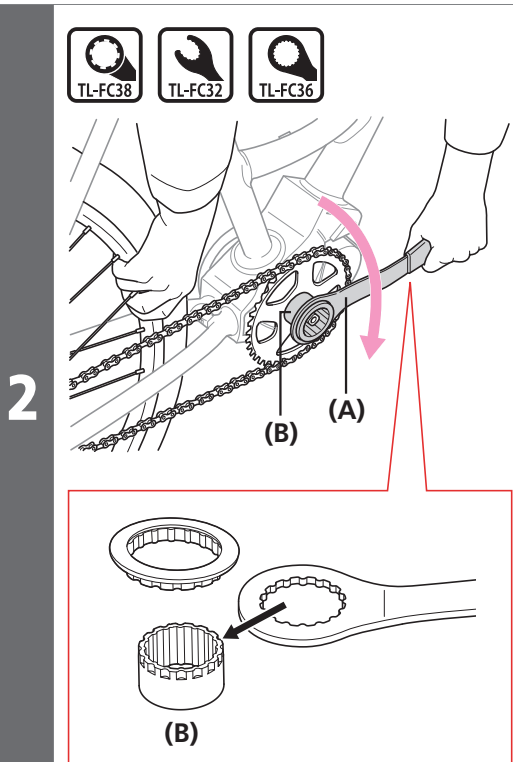

While holding the wheel, use the SHIMANO original tool to loosen the lock ring in the direction shown in the illustration.

- (A) TL-FC32 / FC36
- (B) TL-FC38

NOTE

If using a torque wrench, use TL-FC38 in combination with TL-FC33.

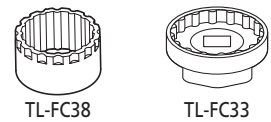

* An impact wrench cannot be used.

TECH TIPS

The lock ring has a left hand thread.

3 Replace the front chainring. To install a front chainring refer to steps 3 to 6 in "Installing and wiring the drive unit"- "Installing the crank and front chainring".

SHIMANO

SHIMANO NORTH AMERICA BICYCLE, INC.

One Holland, Irvine, California 92618, U.S.A. Phone: +1-949-951-5003

SHIMANO EUROPE B.V.

High Tech Campus 92, 5656 AG Eindhoven, The Netherlands Phone: +31-402-612222

SHIMANO INC.

3-77 Oimatsu-cho, Sakai-ku, Sakai City, Osaka 590-8577, Japan

Please note: specifications are subject to change for improvement without notice. (English)

© Feb. 2019 by SHIMANO INC. ITP