

# Dealer's Manual

ROAD	MTB	Trekking
City Touring/ Comfort Bike	URBAN SPORT	E-BIKE

**SHIMANO**  
***ALFINE***

INTER-11

INTER-8

# CONTENTS

<b>IMPORTANT NOTICE.....</b>	<b>3</b>
<b>TO ENSURE SAFETY.....</b>	<b>4</b>
<b>LIST OF TOOLS TO BE USED.....</b>	<b>10</b>
<b>INSTALLATION .....</b>	<b>12</b>
Installation of the sprocket to the hub.....	12
Installation of the CS-S500 sprocket with chain guard.....	13
Installation of the cassette joint to the hub.....	14
Installation of the disc brake rotor .....	16
Installation of the hub to the frame.....	17
Installing the shifter.....	19
Installation of the shifting cable.....	19
<b>ADJUSTMENT .....</b>	<b>32</b>
Adjusting the cassette joint.....	32
<b>MAINTENANCE .....</b>	<b>36</b>
Replacement and assembly of the indicator unit .....	36
For internal 8-speed (oil maintenance kit: Y00298010).....	40
For internal 11-speed (oil maintenance kit: Y13098023).....	44

## IMPORTANT NOTICE

- **This dealer's manual is intended primarily for use by professional bicycle mechanics.**

Users who are not professionally trained for bicycle assembly should not attempt to install the components themselves using the dealer's manuals. If any part of the information on the manual is unclear to you, do not proceed with the installation. Instead, contact your place of purchase or a distributor for assistance.

- Make sure to read all instruction manuals included with the product.
- Do not disassemble or modify the product other than as stated in the information contained in this dealer's manual.
- All manuals and technical documents are accessible online at <https://si.shimano.com>.
- For consumers who do not have easy access to the internet, please contact a SHIMANO distributor or any of the SHIMANO offices to obtain a hardcopy of the User's Manual.
- Please observe the appropriate rules and regulations of the country, state or region in which you conduct your business as a dealer.

**For safety, be sure to read this dealer's manual thoroughly before use, and follow it for correct use.**

The following instructions must be observed at all times in order to prevent personal injury and physical damage to equipment and surroundings. The instructions are classified according to the degree of danger or damage which may occur if the product is used incorrectly.

 **DANGER**

Failure to follow the instructions will result in death or serious injury.

 **WARNING**

Failure to follow the instructions could result in death or serious injury.

 **CAUTION**

Failure to follow the instructions could cause personal injury or physical damage to equipment and surroundings.

## TO ENSURE SAFETY

### WARNING

- **Be sure to follow the instructions provided in the manuals when installing the product.**  
Only use SHIMANO genuine parts. If a component or replacement part is incorrectly assembled or adjusted, it can lead to component failure and cause the rider to lose control and crash.
-  Wear approved eye protection while performing maintenance tasks such as replacing components.

#### Be sure to also inform users of the following:

- Because each bicycle may handle slightly differently depending on the model, be sure to learn the proper braking technique (including brake lever pressure and bicycle control characteristics) and operation of your bicycle. Improper use of your bicycle's brake system may result in a loss of control, which could lead to serious injury due to a fall or collision.
- Check that the wheels are fastened securely before riding the bicycle. You may fall or collide and be seriously injured.

#### ■ Brake

- Do not apply the front brake too strongly. If you do so, the front wheel may lock and the bicycle may fall forward, and serious injury may result.
- Because the required braking distance will be longer during wet weather, reduce your speed and apply the brakes early and gently. You may fall or collide and be seriously injured.
- A wet road surface may cause tires to lose traction; therefore, to avoid this, reduce your speed and apply the brakes early and gently. If the tires lose traction, it may result in serious injury due to a fall or collision.

#### ■ Disc brake

- Keep your fingers away from rotating disc brake rotors. Disc brake rotors are sharp enough to severely injure your fingers if caught within the openings of a disc brake rotor.



- Do not touch the calipers or disc brake rotor while riding or immediately after dismounting from the bicycle. The calipers and disc brake rotor will become hot when the brakes are operated, so you may get burned if you touch them.
- Do not allow any oil or grease to get onto the disc brake rotor and brake pads. Riding the bicycle with oil or grease on the disc brake rotor and brake pads may prevent the brakes from operating and result in serious injury due to a fall or collision.
- Check the thickness of the brake pads and do not use them if they have a thickness of 0.5 mm or less. Doing otherwise may prevent the brakes from operating and result in serious injury due to a fall or collision.

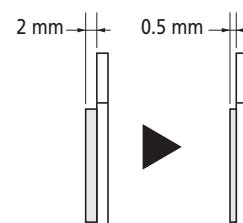

- Do not use the disc brake rotor if it is cracked or warped. The disc brake rotor may break, and result in serious injury due to a fall.
- Do not use the disc brake rotor if its thickness is 1.5 mm or less. Also do not use it if the aluminum surface becomes visible. The disc brake rotor may break, and result in serious injury due to a fall or collision.

**For installation to the bicycle and maintenance**

- When installing the hub to the frame, be sure to install the correct non-turn washers to the left and right sides, and securely tighten the hub nuts to the specified torques. If the non-turn washers are installed on one side only, or if the hub nuts are not tightened sufficiently, the non-turn washer may fall out, which could cause the hub axle to rotate and the cassette joint to turn, resulting in the handlebars being accidentally pulled by the gear shifting cable and an extremely serious accident.
- Assemble the wheel with 3x or 4x lacing, and do not spoke the wheel radially. Otherwise, the spokes or the wheel may get damaged, or noise may occur when braking.

< CT-S500 / CT-S510 >

- Never use alkali- or acid-based solvents such as rust cleaners. If those solvents are used the chain might break and cause serious injury.
- Clean the chain with an appropriate chain cleaner regularly. Intervals between maintenance depend on the use and riding circumstances.
- Use the reinforced connecting pin only for connecting the narrow-type chain. If connecting pins other than reinforced connecting pins are used, or if a reinforced connecting pin or tool which is not suitable for that type of chain is used, sufficient connection force may not be obtained, which could cause the chain to break or skip.
- If it is necessary to readjust the length of the chain due to a change in the number of sprocket teeth, make the cut at some other place than the place where the chain has been joined using a reinforced connecting pin or an end pin. The chain will be damaged if it is cut at a place where it has been joined with a reinforced connecting pin or an end pin.

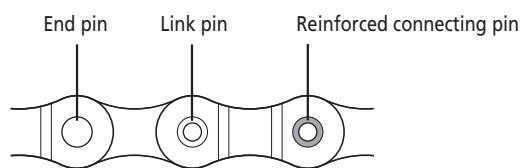

- Check that the tension of the chain is correct and that the chain is not damaged. If the tension is too weak or the chain is damaged, the chain should be replaced. If this is not done, the chain may break and cause serious injury.

 **CAUTION****Be sure to also inform users of the following:**

- Shift the shifter one or two gears at a time. During shifting, reduce the pedal pressure. If you try to force operation of the shifter or suddenly shift three or more gears while the pedals are being turned strongly, your feet may come off the pedals and the bicycle may fall over, which could result in serious injury.

Operating the shifter to multi-shift to a light gear may also cause the outer casing to spring out of the shifter. This does not affect the capabilities of the shifter because the outer casing returns to the original position after shifting.

**■ Disc brake**

- Disc brakes have a bed-in period, and the braking force will gradually increase as the bed-in period progresses. You may lose control of the bicycle, which can result in serious injury due to a fall or collision.

The same thing will happen when the brake pads or disc brake rotor are replaced.

**NOTICE****Be sure to also inform users of the following:**

- The gears can be shifted while lightly pedaling, but on rare occasions the pawls and ratchet inside the hub may produce some noise afterwards as part of normal gear shifting operation.
- The internal geared hub is not completely waterproof. Avoid using the hub in places where water might get inside and do not use high-pressure jets of water to clean the hub, otherwise the internal mechanism may rust.
- The internal geared hub has a built-in mechanism to support shifting, and when this support mechanism operates during shifting, noise or vibration may occur. Depending on the gear position, gear shifting may give different feels. Noise may also occur if the gear is positioned at 5 to 8 (internal 8-speed hub) or 7 to 11 (internal 11-speed hub), when the crank is turned backward or when the bicycle is pushed backward. All of these phenomena occur due to the internal gear shifting mechanism and are not the failure of the internal components.
- Products are not guaranteed against natural wear and deterioration from normal use and aging.
- For maximum performance we highly recommend SHIMANO lubricants and maintenance products.

**For Installation to the Bicycle, and Maintenance:**

- The cassette joint should only be used with sprockets from 16T to 23T.
- It is recommended that the chain ring of the front be set to the following gear ratio.

	Sprocket ratio	Front		Rear											
		Model No.	Chainring	SM-GEAR										CS-S500	
				14	15	16	17	18	19	20	21	22	23	18	20
11-speed	1.8 - 2.0	FC-S501	38T	-	-	-	-	-	X	X	X	-	-	-	-
			39T	-	-	-	-	-	-	X	X	-	-	-	-
			42T	-	-	-	-	-	-	-	X	X	X	-	-
			45T	-	-	-	-	-	-	-	-	-	X	-	-
8-speed	2.0 - 2.25	FC-S501	45T	-	-	-	-	-	-	X	X	X	-	-	X
			42T	-	-	-	-	-	X	X	X	-	-	-	X
			39T	-	-	-	-	X	X	-	-	-	-	X	-

- In order to maintain proper performance, it is recommended that you carry out maintenance such as replacing the oil and applying grease to the internal unit once a year from the start of use (or once about every 2,000 km if the bicycle is used very frequently). If the bicycle is used under harsh conditions, more frequent maintenance is required.  
Also, for carrying out maintenance, the use of SHIMANO internal geared hub grease or a lubrication kit is recommended. If SHIMANO grease or a SHIMANO lubrication kit is not used, problems such as a malfunction in shifting unit may occur.
- If the wheel becomes stiff and difficult to turn, perform an inspection.
- The chainrings and sprockets should be periodically washed with a neutral detergent and lubricated. In addition, cleaning the chain with neutral detergent and lubricating it can be an effective way of extending the life of the chainrings, sprockets, and the chain.

- If the chain keeps skipping during use, replace the chainrings, sprockets, and the chain.
- If using a chain tensioner, use the special CS-S500 18T or 20T sprocket with chain guard. Do not use any other types of sprockets, otherwise the chain may come off the sprockets.

**< SG-S7001-11 >**

- When you perform oil maintenance, use the SG-S700 OIL or TL-S703 maintenance kit.  
When you replace the oil, follow the manual for TL-S703. When you replace the seal on the right side, use TL-S704.  
If SG-S700 OIL is not used, problems such as an oil leakage and gear shifting malfunction may occur.

**< CT-S500 / CT-S510 >**

- Clean the chain tensioner periodically and lubricate all moving parts and pulleys.
- If there is a large amount of play in the pulleys and an abnormal amount of noise is generated while riding, replace the pulleys.
- Do not disassemble the pulley unit.
- If the tension applied is too strong, noise may be generated while riding.
- If the chain becomes elongated and excessive looseness occurs, readjust the chain tension.

**< CT-S510 >**

Applicable hubs	Applicable sprockets	Supported rear dropout thickness	Supported rear dropout shape
Internal 7-speed / 8-speed	16 - 23T	4 - 9 mm	Vertical

- This product is for single front chainrings only.









The actual product may differ from the illustration because this manual is intended chiefly to explain the procedures for using the product.



# **LIST OF TOOLS TO BE USED**

## LIST OF TOOLS TO BE USED

The following tools are required to assemble the product.

Tool		Tool		Tool	
	3 mm hexagon wrench		15 mm spanner		TL-S700-B
	4 mm hexagon wrench		Adjustable wrench		TL-LR10
	10 mm spanner		Screwdriver		

# INSTALLATION

# INSTALLATION

## ■ Installation of the sprocket to the hub

Place the right-hand dust cap B/right-hand dust cap C onto the driver on the right side of the hub body.

Next, install the sprocket and secure it in place with the snap ring.

Specifications	Applicable sprockets	
	Outward assembling	Inward assembling
A	16T-23T	20T-23T
B	16T-23T	

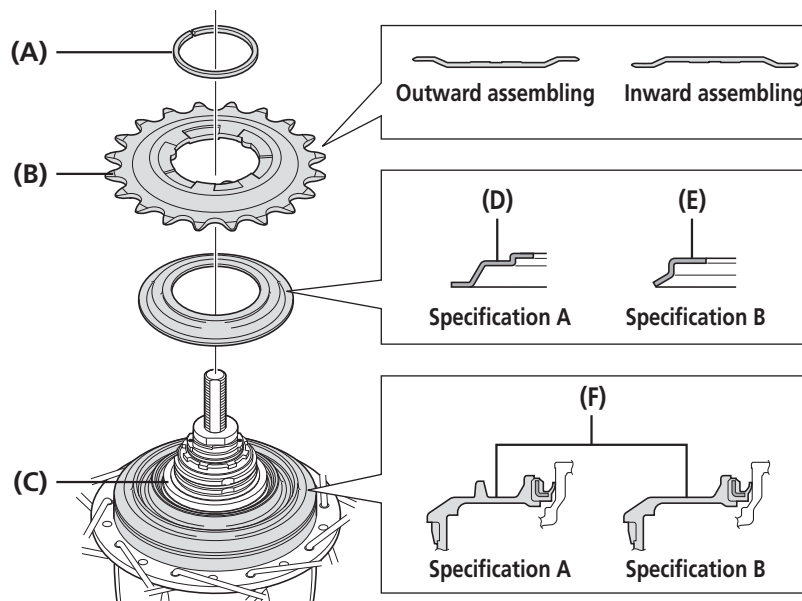

- (A) Snap ring
- (B) Sprocket
- (C) Driver
- (D) Right-hand dust cap C
- (E) Right-hand dust cap B
- (F) Right-hand dust cap A

### NOTICE

Note the orientation of the right-hand dust cap.

**Specification A**  
If the sprocket is an inward assembling sprocket with 19T or fewer or for belt drive specifications, right-hand dust cap A will come into contact with the chain or pulley so specification B should be used instead.

**Specification B**  
If the sprocket is an inward assembling sprocket with 16T and 3 mm teeth or for belt drive specifications, remove right-hand dust cap B before use.

**■ Installation of the CS-S500 sprocket with chain guard**

**1**

Install the chain guard to the right hand dust cap of the hub body, and then install right hand dust cap B to the driver.

Install the right-hand dust cap B in the orientation (z).

- (A) Right hand dust cap B
- (B) Chain guard
- (C) Right hand dust cap
- (D) Driver

**2**

Install the CS-S500 sprocket to the driver on the right side of the hub body with the guard plate facing outward, and secure it in place with the snap ring.

- (A) Driver
- (B) Snap ring
- (C) Guard plate
- (D) CS-S500 Sprocket

## ■ Installation of the cassette joint to the hub

**1**

(A) Driver cap  
(B) Driver  
(z)

Install the driver cap to the driver on the right side of the hub body.  
Install the driver cap in the orientation (z).

- (A) Driver cap
- (B) Driver

**2**

(A) Pulley  
(B) Bracket  
(C) Cassette joint

Turn the cassette joint pulley in the direction of the arrow in the illustration to align the red ● marks on the pulley and the bracket. With the cassette joint in this condition, install it so that the red ● mark on the cassette joint is aligned with the red ● mark on the right side of the hub body.

- (A) Pulley
- (B) Bracket
- (C) Cassette joint

## INSTALLATION

### ▶▶ Installation of the cassette joint to the hub

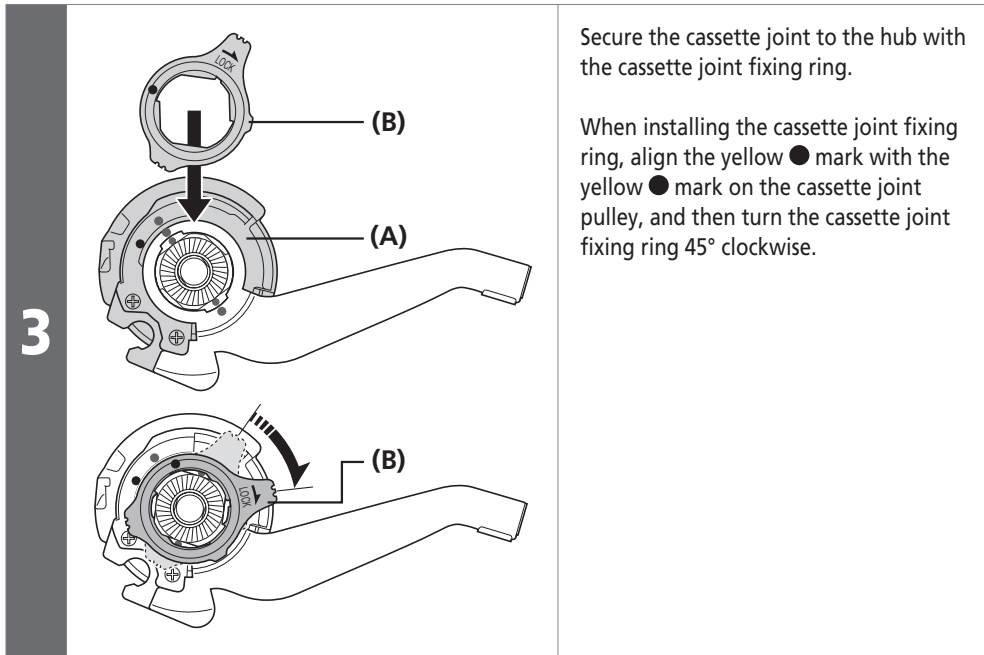

**■ Installation of the disc brake rotor**

Install the disc brake rotor as shown in the illustration.

SG-S7001-8

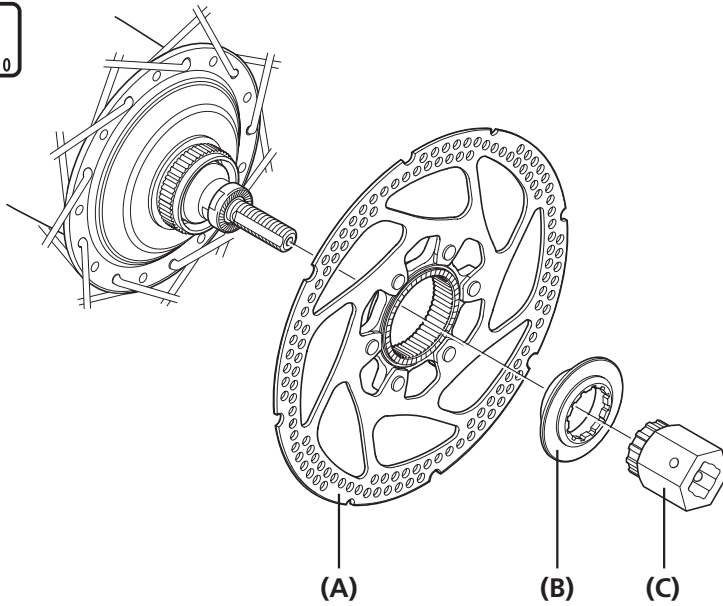

- (A) Disc brake rotor
- (B) Disc brake rotor installation ring
- (C) TL-LR10

**Tightening torque**

 	<p><b>40 N·m</b></p>
------	----------------------

SG-S7001-11

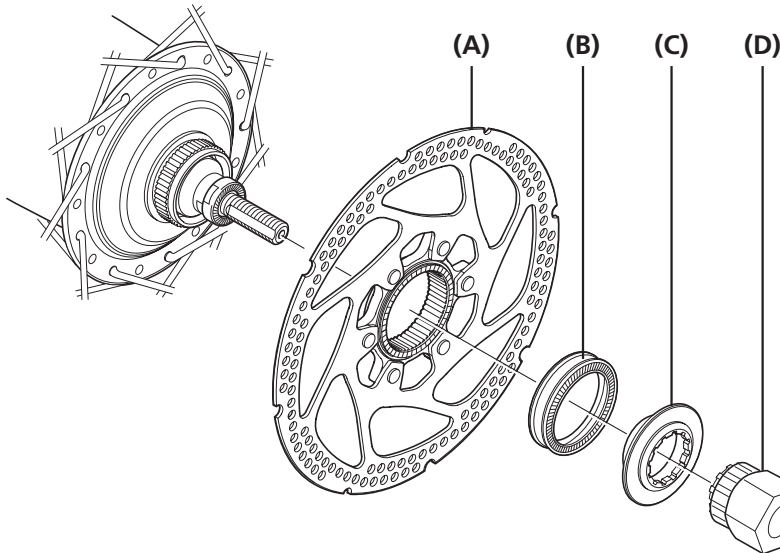

- (A) Disc brake rotor
- (B) Rotor spacer
- (C) Disc brake rotor installation ring
- (D) TL-LR10

**Tightening torque**

 	<p><b>40 N·m</b></p>
------	----------------------



## ■ Installation of the hub to the frame

# 1

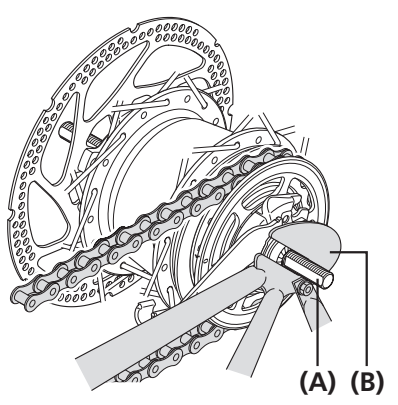

**When not using the chain tensioner**  
Mount the chain on the sprocket, then set the hub axle into the rear dropout.

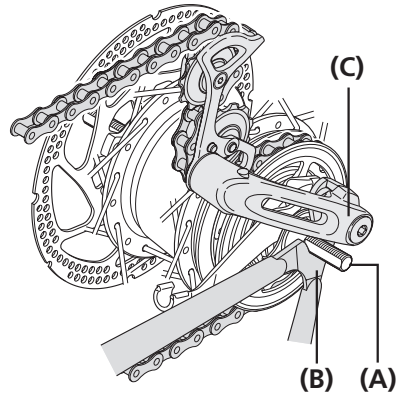

**When using the chain tensioner**  
Mount the chain on the sprocket, then set the hub axle into the rear dropout.

- (A) Hub axle
- (B) Rear dropout
- (C) Chain tensioner

**NOTICE**

When using the chain tensioner, be sure to read these instructions in conjunction with the instructions for the CT-S500 chain tensioner.

# 2

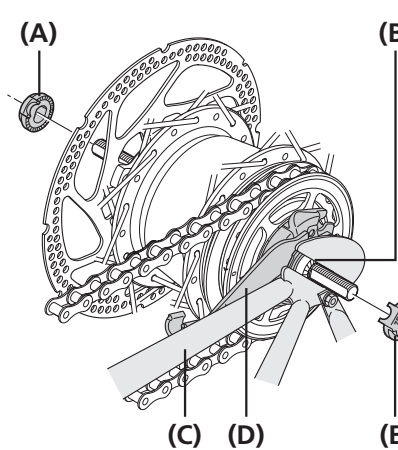

Place the non-turn washers onto the right side and left side of the hub axle.

At this time, turn the cassette joint so that the protrusions of the non-turn washers fit into the grooves in the rear dropout and align the joint to be almost parallel to the chainstay.

- (A) Non-turn washer (for left side)
- (B) Rear dropout groove
- (C) Chainstay
- (D) Cassette joint
- (E) Non-turn washer (for right side)

 **TECH TIPS**

- Use a non-turn washer that matches the shape of the rear dropout. Different non-turn washers are used for the left and right sides.
- The protrusion should be on the rear dropout side.
- Install the non-turn washer so that the protrusion fits securely in the rear dropout groove at the front and back sides of the hub axle.



Rear dropout	Non-turn washer		
	Mark / Color		Size
	Right	Left	
Standard	5R/Yellow	5L/Brown	$\theta \leq 20^\circ$
	7R/Black	7L/Gray	$20^\circ \leq \theta \leq 38^\circ$
	9R/Light green	9L/Light brown	
Reversed	6R/Silver	6L/White	$\theta = 0^\circ$
Reversed (full chain case)	5R/Yellow	5L/Brown	$\theta = 0^\circ$
Vertical	8R/Blue	8L/Green	$\theta = 60^\circ - 90^\circ$

## INSTALLATION

### Installation of the hub to the frame

3



15mm

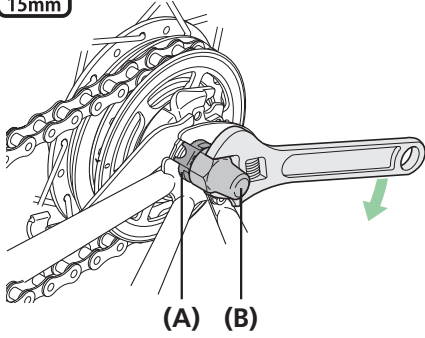

Take up the slack in the chain and secure the wheel to the frame with the cap nuts.

- (A) Non-turn washer
- (B) Cap nut
- (C) Carrier stay
- (D) Washer
- (E) Mudguard stay

#### Tightening torque



15mm

30 - 45 N·m

#### NOTICE

When installing the hub to the frame, the chain guard may come off, so check that the chain guard is securely installed so that it will not come off.  
If it is not fully installed, noise may be generated.

Chain guard

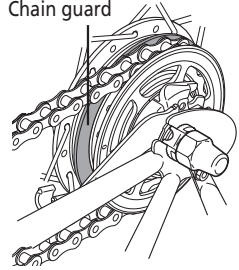

15mm

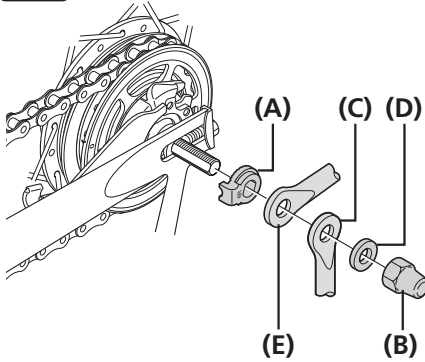

When installing a part such as a mudguard stay to the hub axle, install in the order shown in the illustration.

## ■ Installing the shifter

1

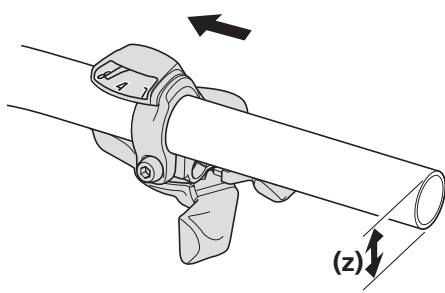

Mount the shifter on to the handlebar.

**(z)**  $\Phi 22.2$

**NOTICE**

Use a handlebar with an outer diameter of  $\Phi 22.2$  mm.

2

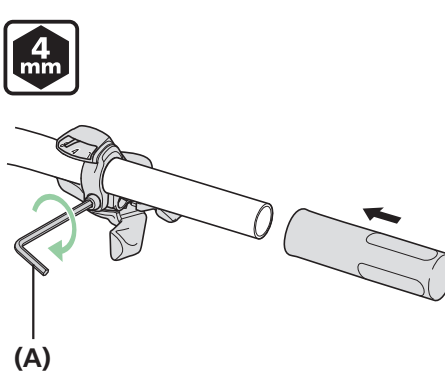

Mount the grip on to the handlebar and secure the shifter.

**(A)** 4 mm hexagon wrench

Tightening torque	
<div style="border: 1px solid black; padding: 2px; display: inline-block;">4 mm</div>	5 - 7 N·m

**NOTICE**

Use a handlebar grip with a maximum outer diameter of  $\Phi 32$  mm.

## ■ Installation of the shifting cable

For internal 8-speed

Shifter side

1

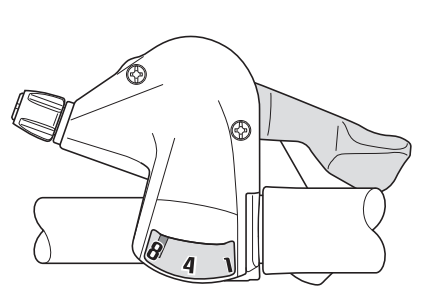

Set the shifter to **8**.

**NOTICE**

- Use a shifting cable with one inner cable drum.  
Cable with one inner cable drum: OT-SP41

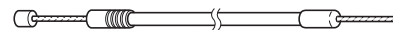

- Make sure that the sealed outer cap is at the shifter end.

**2** 

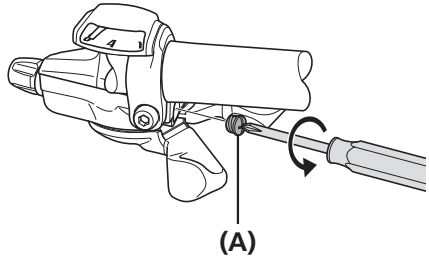

(A)

Loosen and remove the inner hole cap.

**(A)** Inner hole cap

**3**

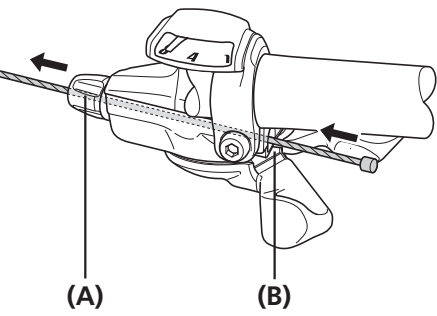

(A) (B)

Insert the inner cable into the winder unit cable fixing groove, then pass it through the hole in the cable adjustment barrel.

**(A)** Hole in cable adjustment barrel  
**(B)** Winder unit cable fixing groove

**4**

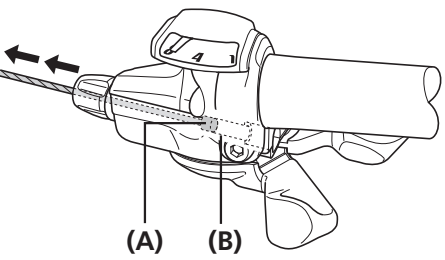

(A) (B)

Pull the inner cable so that the inner cable drum fits into the hole in the winder unit.

**(A)** Inner cable drum  
**(B)** Hole in winder unit

**5** 

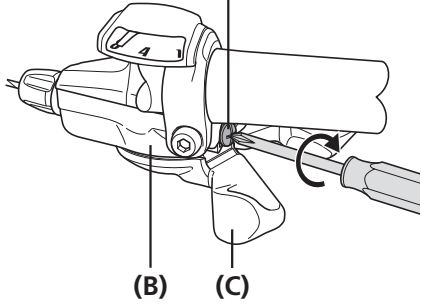

(A) (B) (C)

Screw in the inner hole cap as shown in the illustration until it stops.

If it is turned any further, it will damage the screw thread in the cover.

In addition, the unit cover may become bent, which may cause an obstruction between the unit cover and the main lever, and the main lever may not operate correctly.

If the main lever does not return properly, loosen the inner hole cap slightly to make a gap between the main lever and the unit cover, and check that this improves the returning of the main lever.

**(A)** Inner hole cap  
**(B)** Unit cover  
**(C)** Main lever

## INSTALLATION

### Installation of the shifting cable

6

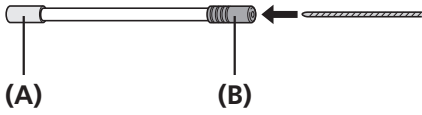

Pass the inner cable through the OT-SP41 outer casing through the end with the plastic cap.

(A) Aluminum cap

(B) Plastic cap



#### TECH TIPS

If cutting the outer casing, cut it near the end with the plastic cap while the cap is still attached.

Then make the cut end perfectly round and attach the plastic cap.

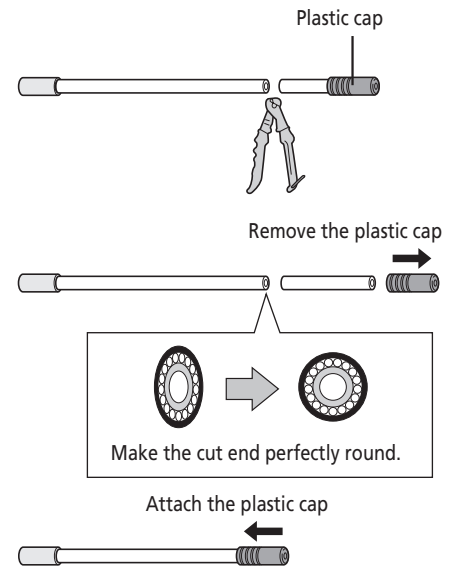

Cassette joint end

1

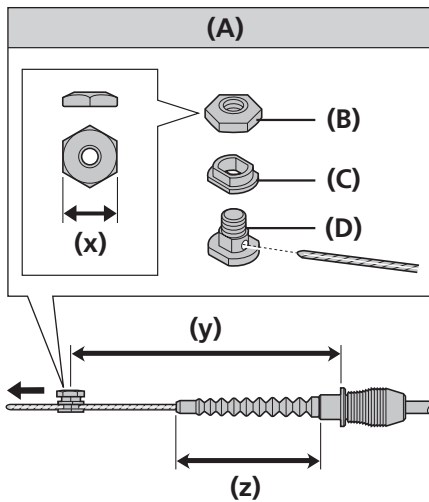

After checking that the end of the outer casing is sitting securely in the cable adjustment barrel of the shifter, attach the inner cable fixing bolt unit to the inner cable.

Then, pull the inner cable while attaching the inner cable fixing bolt unit.

- (x) 10 mm
- (y) 145 mm
- (z) 63 mm or less

- (A) Inner cable fixing bolt unit
- (B) Inner cable mounting nut
- (C) Inner cable fixing washer
- (D) Inner cable fixing bolt

Tightening torque	
	3.5 - 5.5 N·m

**NOTICE**  
Do not use this inner cable fixing bolt unit with the CJ-4530 cassette joint.

**TECH TIPS**

When installing the inner cable fixing bolt unit, use the setting tool TL-S700-B.

2

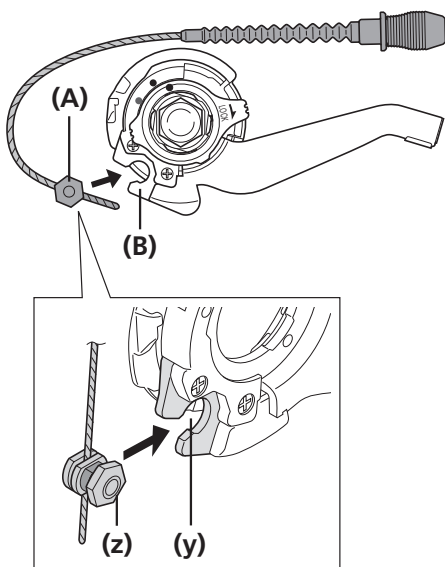

Bring the cable around to the cassette joint pulley, hold it so that the inner cable mounting nut is facing outwards (towards the rear dropout), then slide the flats part (z) of the inner fixing washer into the notch (y) in the pulley.

- (A) Inner cable mounting nut
- (B) Pulley

**3**

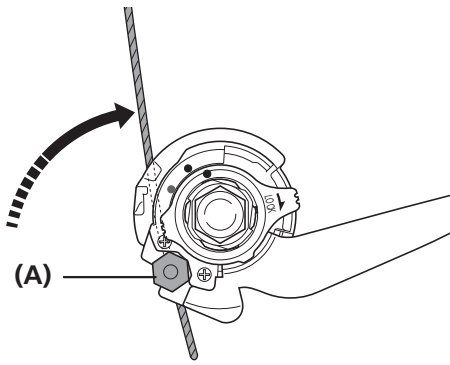

Turn the cable 60° counterclockwise and attach it to the hook.

**(A)** Hook

**4**

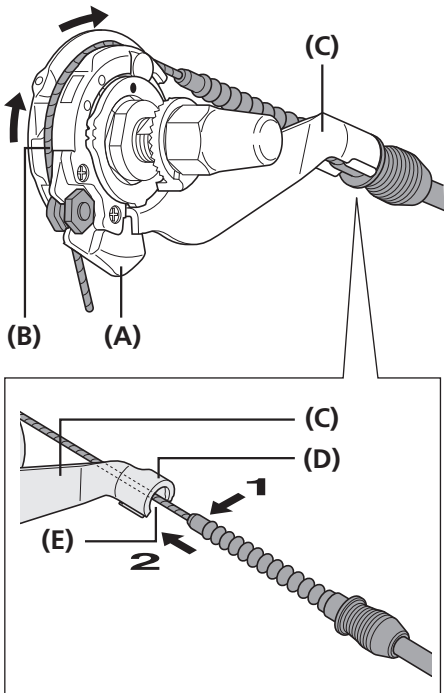

Set the inner cable in the pulley as shown in the figure and, while holding the rubber cover, insert the rubber bellows of the inner cable into the slit in the cassette joint bracket (y) and securely set the outer casing holder body into the outer casing holder section of the cassette joint (z).

- (A)** Pulley
- (B)** Inner cable
- (C)** Bracket
- (D)** Outer casing holder section
- (E)** Slit

**NOTICE**

Check that the inner cable is correctly seated inside the pulley guide.

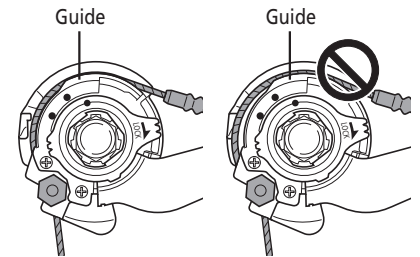

**5**

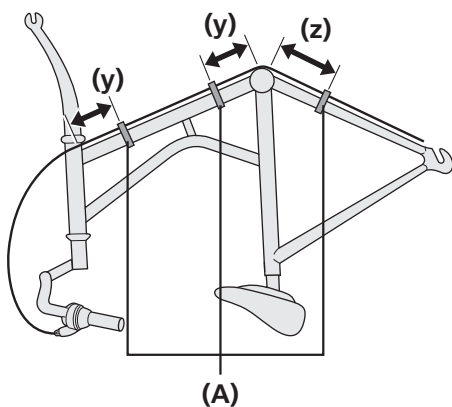

Secure the cable to the frame with the outer casing bands.

- (y)** 10 cm
- (z)** 15 cm

**(A)** Outer casing bands

**Disconnecting the shifting cable when removing the rear wheel from the frame**

1

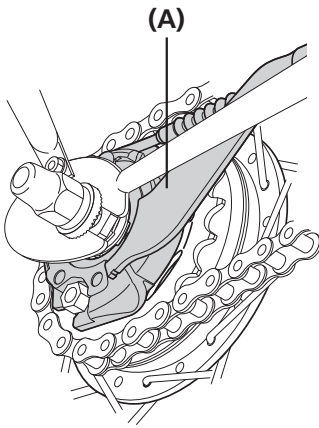

Disconnect the cable from the cassette joint when removing the rear wheel from the frame.

**(A)** Cassette joint

1

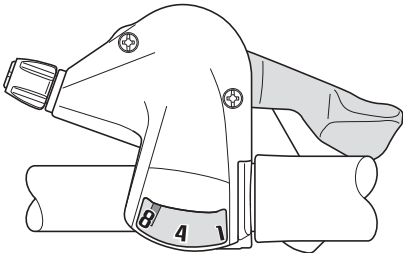

Set the shifter to **8**.

2

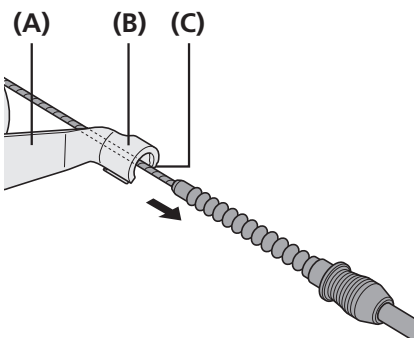

Pull out the outer casing from the outer casing holder section of the cassette joint, and remove the inner cable from the slit in the bracket.

**(A)** Bracket  
**(B)** Outer casing holder section  
**(C)** Slit

3

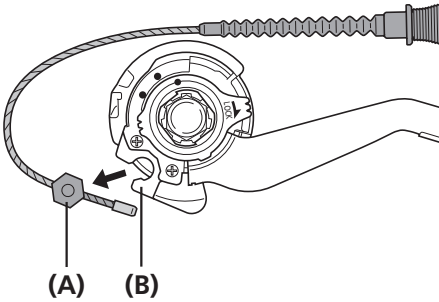

Remove the inner cable fixing bolt unit from the cassette joint pulley.

**(A)** Inner cable fixing bolt unit  
**(B)** Cassette joint pulley

**NOTICE**

If reinstalling the cable, refer to steps 2 to 4 in "Cassette joint end".



**For internal 11-speed**

**Shifter side**

**1**

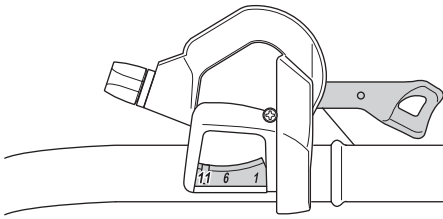

Set the shifter to **11**.

**NOTICE**

- Use a shifting cable with one inner cable drum.  
Cable with one inner cable drum: OT-SP41

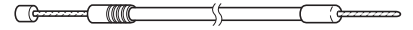

- Make sure that the sealed outer cap is at the shifter end.

**2**

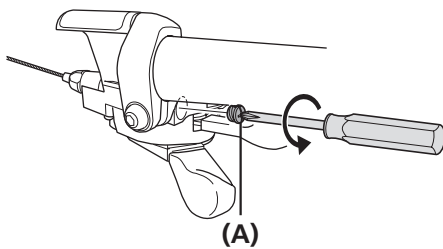

Loosen and remove the inner hole cap.

**(A)** Wire end hooking cap

**3**

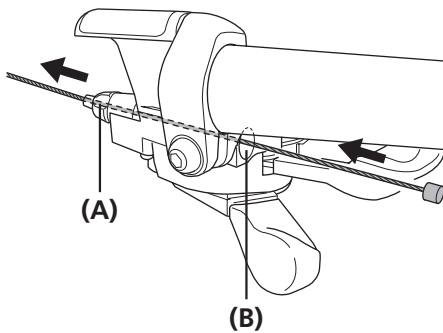

Insert the inner cable into the hole in the winder unit, and then pass it through the hole in the cable adjustment barrel.

**(A)** Hole in cable adjustment barrel  
**(B)** Hole in winder unit

**4**

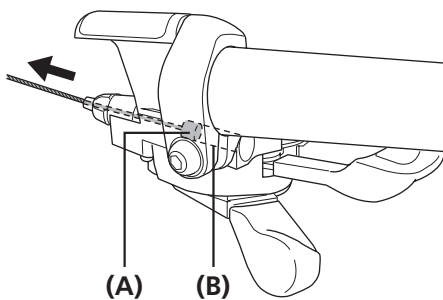

Pull the inner cable so that the inner cable drum fits into the hole in the winder unit.

**(A)** Inner cable drum  
**(B)** Hole in winder unit

5

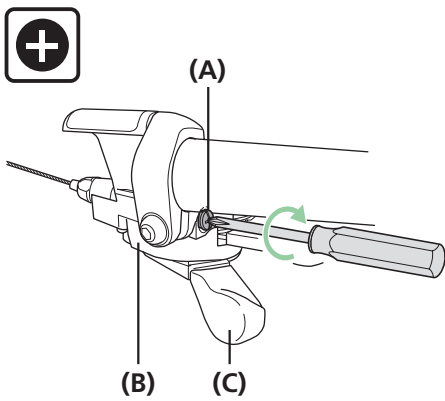

Screw in the inner hole cap as shown in the illustration until it stops.

If it is turned any further, it will damage the screw thread in the cover.

In addition, the unit cover may become bent, which may cause an obstruction between the unit cover and the main lever, and the main lever may not operate correctly.

If the main lever does not return properly, loosen the inner hole cap slightly to make a gap between the main lever and the unit cover, and check that this improves the returning of the main lever.

- (A) Inner hole cap
- (B) Unit cover
- (C) Main lever

Tightening torque



0.3 - 0.5 N·m

6

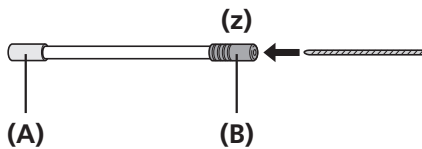

Pass the inner cable through the OT-SP41 outer casing through the end with the plastic cap.

(z) Lever side

- (A) Aluminum cap
- (B) Plastic cap

TECH TIPS

If cutting the outer casing, cut it near the end with the plastic cap while the cap is still attached.

Then make the cut end perfectly round and attach the plastic cap.

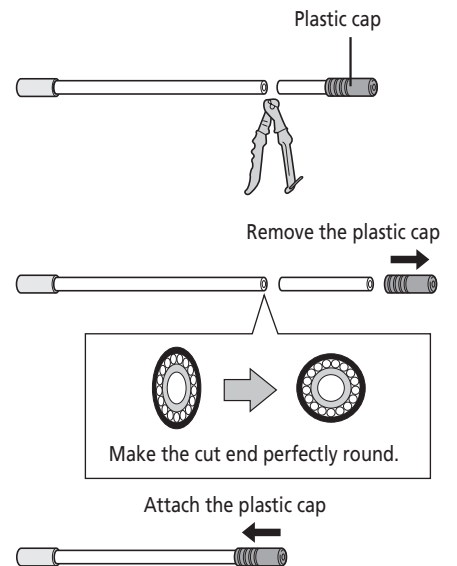

Cassette joint end

1

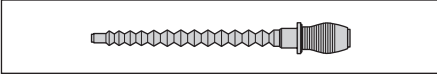
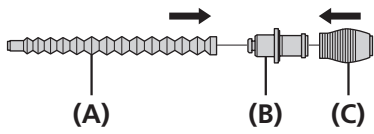

Install the rubber cover and rubber bellows to the outer casing holder body.

- (A) Rubber bellows
- (B) Outer casing holder body
- (C) Rubber cover

2

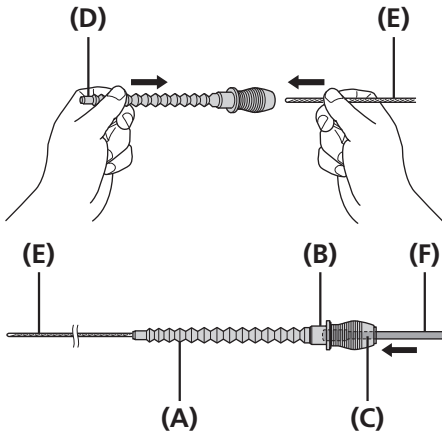

Wipe away any grease which may be on the inner cable and, while holding the end of the rubber bellows, pass the inner cable through. Be careful not to pierce the rubber bellows with the end of the inner cable at this time.

Slide the rubber bellows onto the inner cable.

After this, insert the outer casing into the rubber cover and set it into the outer casing holder body. Push the outer casing so that it securely touches the holder body.

- (A) Rubber bellows
- (B) Outer casing holder body
- (C) Rubber cover
- (D) End of rubber bellows
- (E) Inner cable
- (F) Outer casing

**NOTICE**

Use a new inner cable. Do not use a cable which has had the end cut off. Pay attention to the end of the inner cable.



**3**

TL-S700-B  
10mm

(A)

(B)

(C)

(D)

(x)

(y)

(z)

After checking that the end of the outer casing is sitting securely in the cable adjustment barrel of the shifter, attach the inner cable fixing bolt unit to the inner cable.

Then, pull the inner cable while attaching the inner cable fixing bolt unit.

- (x) 10 mm
- (y) 184 mm
- (z) 75 mm or less

- (A) Inner cable fixing bolt unit
- (B) Inner cable mounting nut
- (C) Inner cable fixing washer (Black)
- (D) Inner cable fixing bolt (Black)

Tightening torque	
	3.5 - 5.5 N·m

**NOTICE**

This inner cable fixing bolt unit is designed only for CJ-S700. 7-step and 8-step fixing bolt units cannot be used.

**TECH TIPS**

When installing the inner cable fixing bolt unit, use the setting tool TL-S700-B.

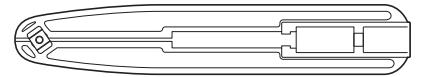

**4**

(A)

Turn the lever of the pulley clockwise. In the following steps 5 and 7, continue to work in this condition.

- (A) Pulley lever

**5**

(A)

(B)

(z)

(y)

Bring the cable around to the cassette joint pulley, hold it so that the inner cable mounting nut is facing outwards (towards the rear dropout), then slide the flats part (z) of the inner fixing washer into the notch (y) in the pulley.

- (A) Inner cable mounting nut
- (B) Pulley

**6**

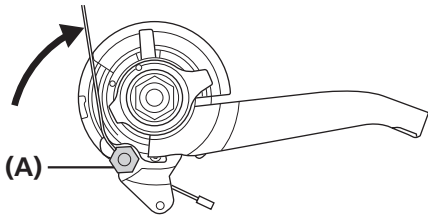

Turn the cable 60° counterclockwise and attach it to the hook.

**(A)** Hook

**7**

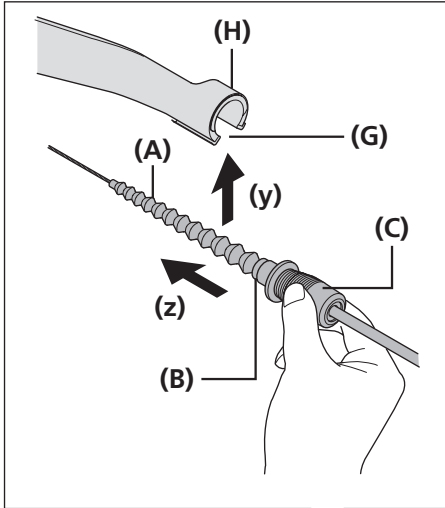

Set the inner cable in the pulley as shown in the figure and, while holding the rubber cover, insert the rubber bellows of the inner cable into the slit in the cassette joint bracket (y) and securely set the outer casing holder body into the outer casing holder section of the cassette joint (z). Be careful not to damage the rubber bellows at this time.

- (A)** Rubber bellows
- (B)** Outer casing holder body
- (C)** Rubber cover
- (D)** Inner cable
- (E)** Pulley
- (F)** Bracket
- (G)** Slit
- (H)** Outer casing holder section

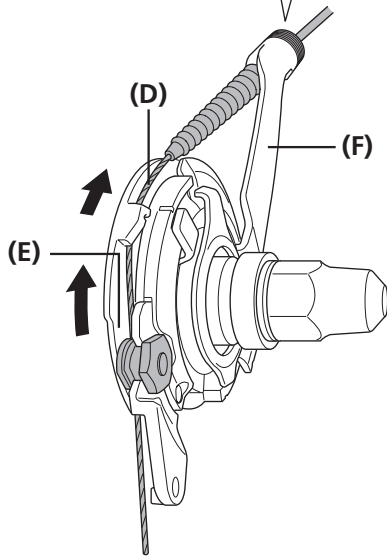

**NOTICE**

Check that the inner cable is correctly seated inside the pulley guide.

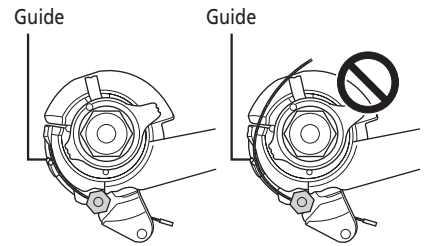

**8**

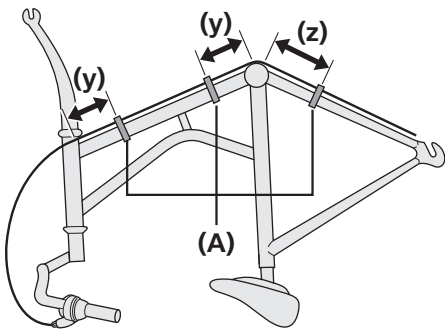

Secure the cable to the frame with the outer casing bands.

- (y)** 10 cm
- (z)** 15 cm

**(A)** Outer casing bands

**Disconnecting the shifting cable when removing the rear wheel from the frame**

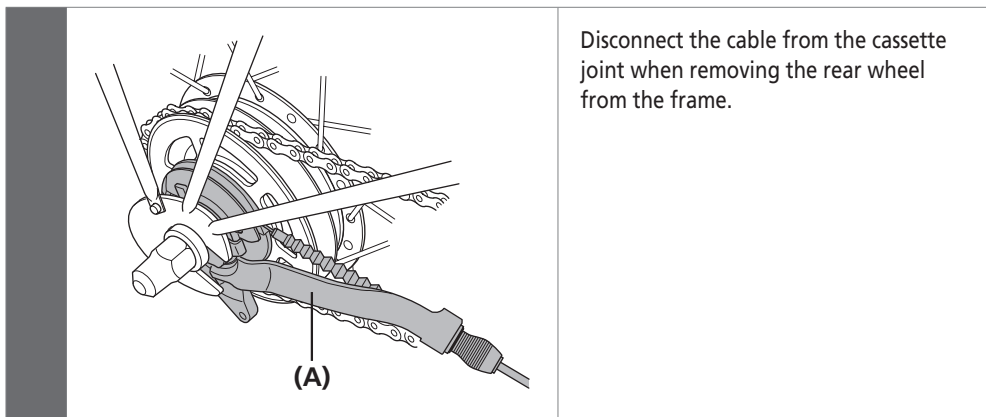

Disconnect the cable from the cassette joint when removing the rear wheel from the frame.

**(A)** Cassette joint

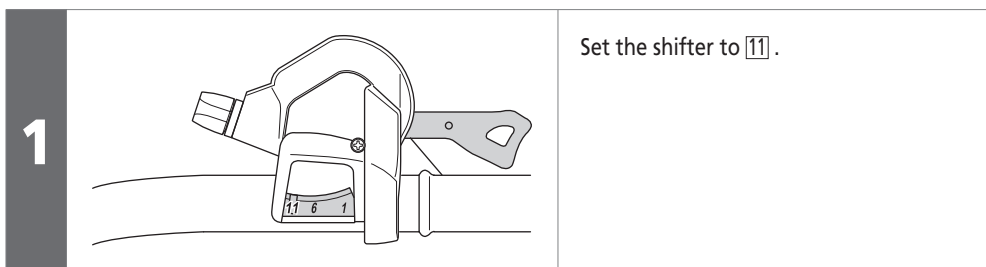

Set the shifter to 1.

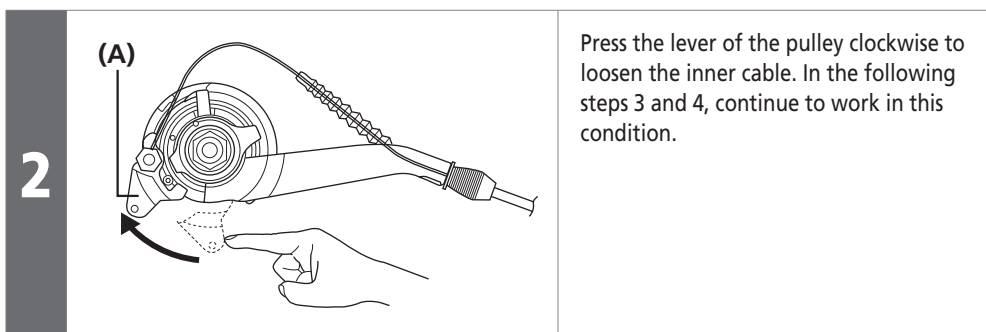

Press the lever of the pulley clockwise to loosen the inner cable. In the following steps 3 and 4, continue to work in this condition.

**(A)** Pulley lever

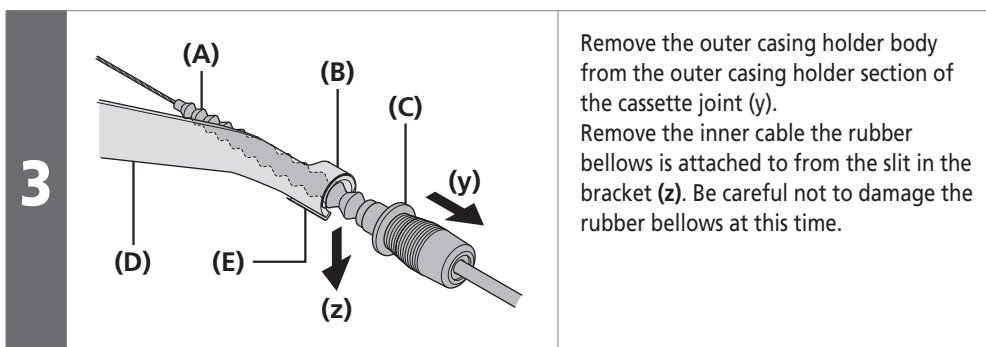

Remove the outer casing holder body from the outer casing holder section of the cassette joint (y). Remove the inner cable the rubber bellows is attached to from the slit in the bracket (z). Be careful not to damage the rubber bellows at this time.

- (A)** Rubber bellows
- (B)** Outer casing holder section
- (C)** Outer casing holder body
- (D)** Bracket
- (E)** Slit

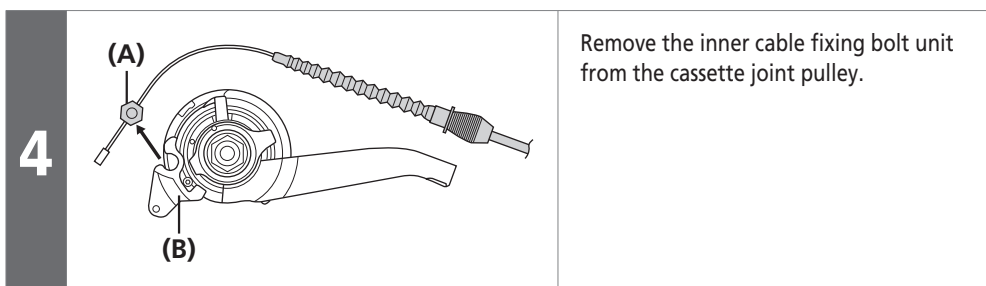

Remove the inner cable fixing bolt unit from the cassette joint pulley.

- (A)** Inner cable fixing bolt unit
- (B)** Cassette joint pulley

**NOTICE**

If reinstalling the cable, refer to steps 4 to 7 in "Cassette joint end".

# ADJUSTMENT

# ADJUSTMENT

## ■ Adjusting the cassette joint

For internal 8-speed

1

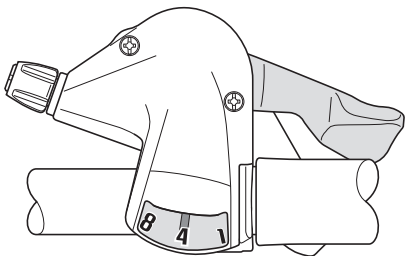
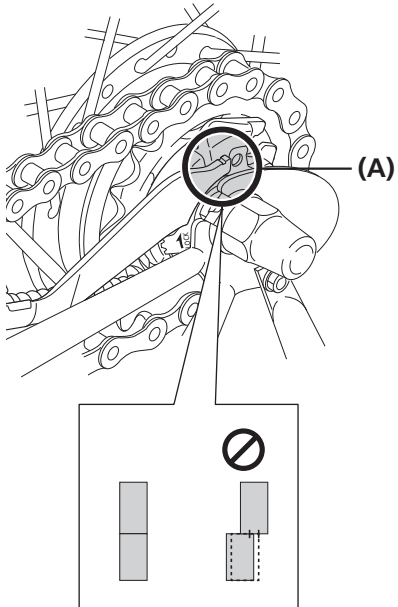
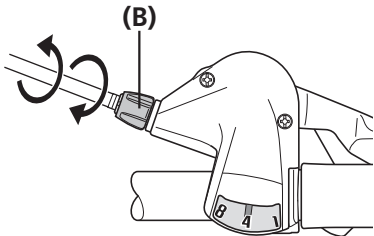
Set the shifter from **8** to **4**.

Check to be sure that the yellow setting lines on the cassette joint bracket and pulley are aligned at this time.

If the yellow setting lines are not aligned, turn the cable adjustment barrel of the shifter to align the setting lines.

After this, move the shifter again from **4** to **8** then back to **4**, and re-check that the yellow setting lines are aligned.

- (A)** Yellow setting lines
- (B)** Cable adjustment barrel

### TECH TIPS

- The yellow setting lines on the cassette joint are located in two places. Use the one that is easiest to see.

< When bicycle is standing up >

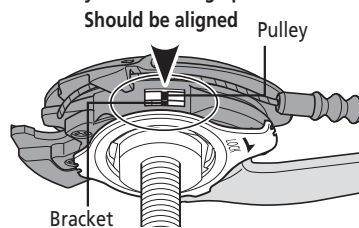

< When bicycle is upside down >

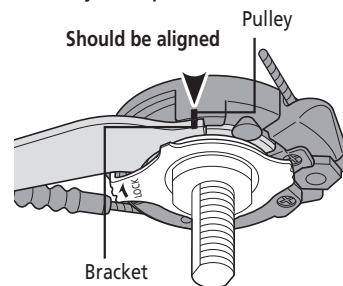



## ADJUSTMENT

### ▶▶ Adjusting the cassette joint

2

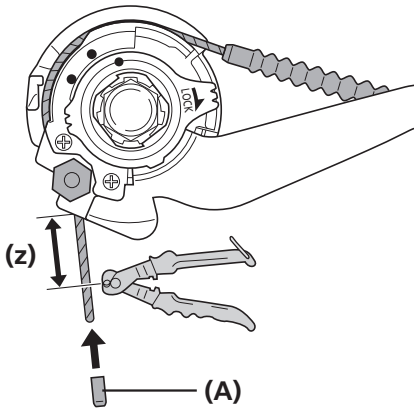

After adjusting the cassette joint, cut off the excess length of inner cable.

Then install the inner end cap.

**(z)** 15 - 20 mm

**(A)** Inner end cap

**For internal 11-speed**

**1**

Set the shifter from **11** to **6**.  
Check to be sure that the yellow setting lines on the cassette joint bracket and pulley are aligned at this time.

If the yellow setting lines are not aligned, turn the cable adjustment barrel of the shifter to align the yellow setting lines.

After this, move the shifter again from **6** to **11** then back to **6**, and re-check that the yellow setting lines are aligned.

- (A)** Yellow setting lines
- (B)** Cable adjustment barrel

**TECH TIPS**

- The yellow setting lines on the cassette joint are located in two places. Use the one that is easiest to see.

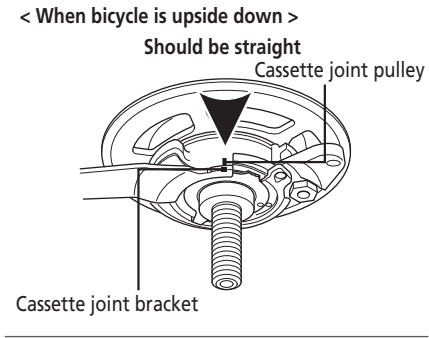
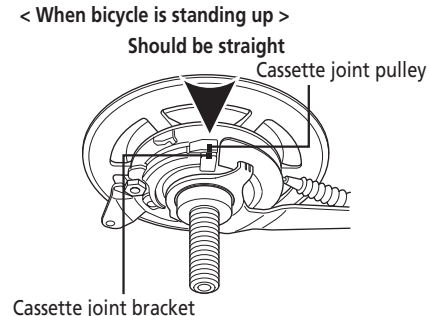

**2**

After adjusting the cassette joint, cut off the excess length of inner cable.

Then install the inner end cap. After installing the inner end cap, slightly bend the inner cable outward (towards the rear dropout) so that it does not touch the chain.

**(z)** 25 - 30 mm

- (A)** Inner end cap

# MAINTENANCE

# MAINTENANCE

## ■ Replacement and assembly of the indicator unit

Disassembly and assembly should only be carried out when removing and replacing the indicator unit.

### For internal 8-speed

#### Removal

1

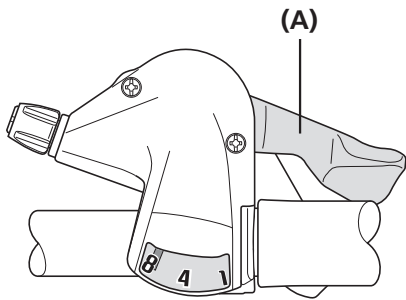

Operate the release lever 7 times or more to set it to **8**.

**(A)** Release lever

2

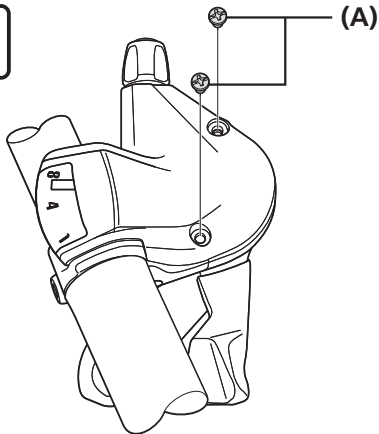

Loosen and remove the two cover fixing screws which are securing the indicator unit.

**(A)** Cover fixing screws

▶▶ Replacement and assembly of the indicator unit

3

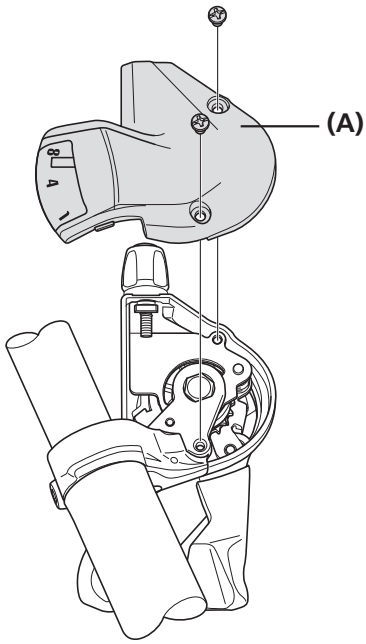

Remove the indicator unit as shown in the illustration.

(A) Indicator unit

## Installation

1

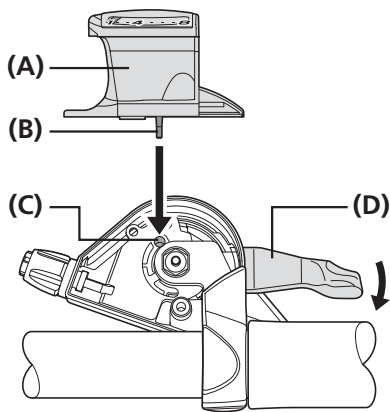

Check that the needle of the indicator is on the left side ( [8] position), and then install the indicator unit so that it is facing straight upward.

Insert the pin of the change plate that is protruding from the bottom of the indicator unit into the hole in the winder unit at this time.

- (A) Indicator unit
- (B) Pin of change plate
- (C) Hole in winder unit ( [8] position)
- (D) Release lever

2

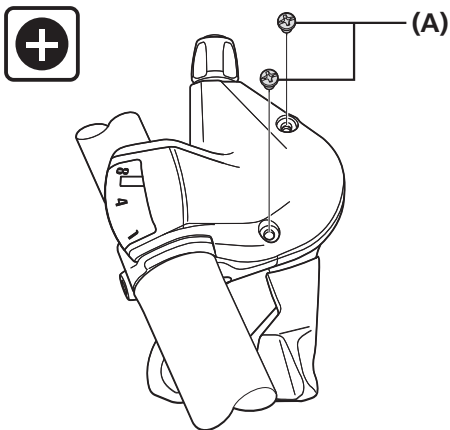

Secure the indicator unit with the two cover fixing screws.

- (A) Cover fixing screws

### Tightening torque



0.3 - 0.5 N·m

3

Operate the main and the release levers, to check their operation.

If they do not operate correctly, reinstall the indicator unit while taking particular note of step 1.

**For internal 11-speed**

**Removal**

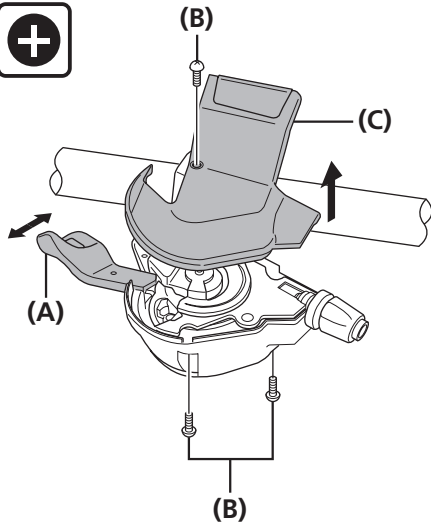

Operate the release lever 10 times or more to set it to **[11]**.

Loosen and remove the three cover fixing screws which are securing the indicator unit.

Remove the indicator unit as shown in the illustration.

- (A)** Release lever
- (B)** Cover fixing screws
- (C)** Indicator unit

**Installation**

**1**

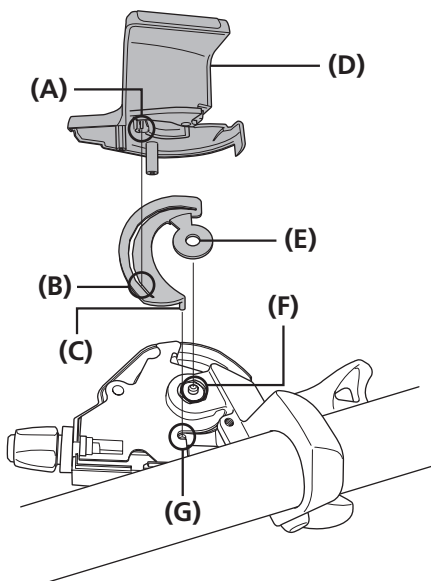

Check that the needle of the indicator is on the left side (**[11]** position), and then install the indicator unit so that it is facing straight upward.

At this time, check that the main axle is installed in the cam unit hole and that the pin of the cam unit is installed in the winder unit hole, and then insert the indicator shaft protruding from the bottom of the indicator unit into the groove of the cam unit.

- (A)** Indicator shaft
- (B)** Cam unit groove (**[11]** position)
- (C)** Cam unit pin
- (D)** Indicator unit
- (E)** Cam unit hole
- (F)** Main axle
- (G)** Winder unit hole

**2**

Secure the indicator unit with the three cover fixing screws.

**3**

Operate the main and the release levers, to check their operation.

If they do not operate correctly, reinstall the indicator unit while taking particular note of step 1.

**Tightening torque**



**0.3 - 0.5 N·m**

▶▶ For internal 8-speed (oil maintenance kit: Y00298010)

## ■ For internal 8-speed (oil maintenance kit: Y00298010)

Content of kit: WB maintenance oil, container

### Important safety information

#### WARNING

- When lubricating the internal unit, be careful that no oil gets on the disc brake rotor, pads, on the rim when using rim brakes, etc. If oil gets on any of these parts, there is a danger that brake performance may be reduced. Take care of this problem according to the procedures in the brake instruction manual.
- Since there is a risk of explosion or fire, do not smoke, eat, or drink while using this oil. In addition, keep it away from ignition sources such as heat, sparks, open flames, or high temperatures and prevent it from catching fire due to static electricity sparks or other sparks.
- Use only outdoors or in a well-ventilated area. Inhalation of oil mist or vapors may cause nausea. Be careful to provide ventilation and use a respirator type mask. If mist or vapor is inhaled, go immediately to an area with fresh air. Cover up with a blanket. Stay warm and stable and seek professional medical advice.

#### Cautions regarding handling of WB maintenance oil:

- Use appropriate eye protection when handling, and avoid contact with eyes. In the event of eye contact, flush with fresh water and seek medical assistance immediately. Contact with eyes may result in irritation.
- Use gloves when handling. In the event of skin contact, wash well with soapy water. Contact with skin may cause a rash and discomfort.
- Do not drink. If it is drunk by mistake, do not induce vomiting; make the affected person drink 1 to 2 cups of water and seek medical assistance immediately. If the affected person loses consciousness, do not give the person anything by their mouth. If vomiting occurs naturally, tilt the body to prevent inhalation.
- After use, be sure to wash hands thoroughly.
- Keep the container sealed to prevent foreign objects and moisture from getting inside, and store it in a cool, dark area away from direct sunlight.
- Keep out of reach of children.
- Dispose of used oil, old oil, or oil used for cleaning in accordance with the method stipulated by the law.
- In order to maintain proper performance, it is recommended that you lubricate the internal unit once a year from the start of use (or once about every 2,000 km if the bicycle is used very frequently).
- Do not use oil other than WB maintenance oil. Problems such as an oil leakage and gear shifting malfunction may occur.
- Disposal of used oil: Follow local county and/or state codes for disposal. Use caution when preparing the oil for disposal.
- Read this manual carefully, and keep it in a safe place for later reference.
- For the latest product safety data sheets, check the website <https://si.shimano.com>.



▶▶ For internal 8-speed (oil maintenance kit: Y00298010)

<p>1</p>		<p>Fill the bottle with WB oil to a height of 95 mm.</p> <p><b>(z)</b> 95 mm</p>
----------	---	--

<p>2</p>		<p>Immerse the internal unit into the oil from the left side. Immerse until the oil reaches up to ring gear unit 1.</p> <p><b>(z)</b> Ring gear unit 1</p>
----------	---	--

<p>3</p>		<p>Keep the internal unit immersed as illustrated for approximately 90 seconds.</p>
----------	--	---

▶ For internal 8-speed (oil maintenance kit: Y00298010)

**4**



Remove the internal unit from the oil.

**5**



Let the excess oil drain off for approximately 60 seconds.

 **TECH TIPS**

- <Maintenance oil>
- The maintenance oil is reusable. Refill it as needed.
  - Store it with the lid closed after use.

**NOTICE**

After oil maintenance, it is recommended that you apply Grease (Y04130100) to the ball retainers, snap ring, brake shoe, and pinion gears.

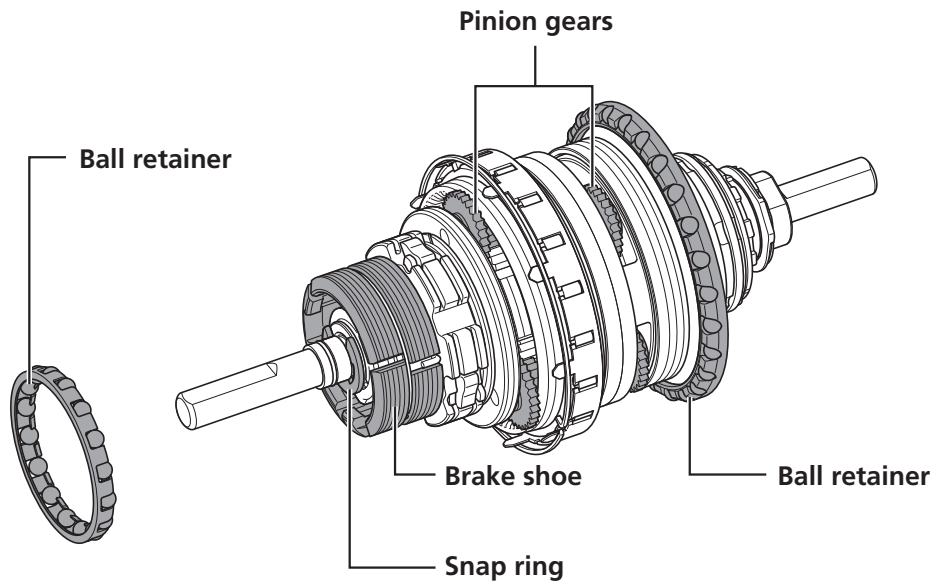

The illustration shows an example.

▶ For internal 8-speed (oil maintenance kit: Y00298010)

Reassemble the hub.

- (1) Use the left-hand cone (or the stop nut for the coaster brake type) to adjust the hub so that the hub shell rotates smoothly and there is no excess play in the hub axle. Ensure that the side of the stop nut without a protrusion is facing up.
- (2) Tighten the left-hand lock nut.
  - For the disc brake, roller brake, or V brake type: 24.5 to 29.4 N·m
  - For the coaster brake or coaster brake (with disc brake) type: 17.7 to 24.5 N·m

In the case of roller brake type

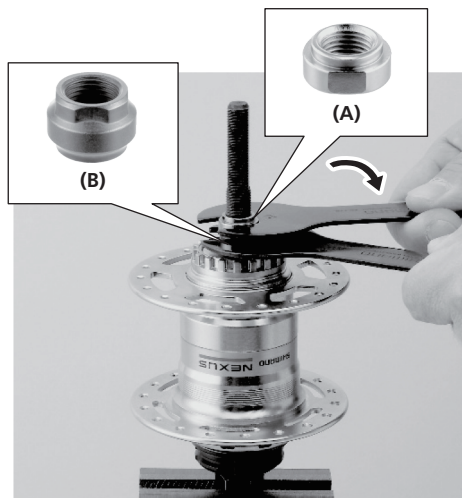

The image shows an example.

- 
- (A) Left-hand lock nut
  - (B) Left-hand cone
- 

In the case of coaster brake type

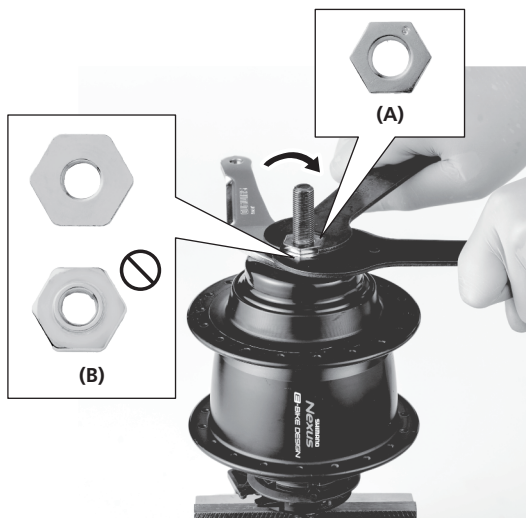

The image shows an example.

- 
- (A) Left-hand lock nut
  - (B) Stop nut
-

▶▶ For internal 11-speed (oil maintenance kit: Y13098023)

## ■ For internal 11-speed (oil maintenance kit: Y13098023)

Content of kit: syringe, tube, bleed nipple, O-ring, container

### Important safety information

#### WARNING

- When replacing the oil, be careful that no oil gets on the disc brake rotor, pads, on the rim when using rim brakes, etc. If oil gets on any of these parts, there is a danger that brake performance may be reduced. Take care of this problem according to the procedures in the brake instruction manual.
- Since there is a risk of explosion or fire, do not smoke, eat, or drink while using this oil. In addition, keep it away from ignition sources such as heat, sparks, open flames, or high temperatures and prevent it from catching fire due to static electricity sparks or other sparks.
- Use only outdoors or in a well-ventilated area. Inhalation of oil mist or vapors may cause nausea. Be careful to provide ventilation and use a respirator type mask. If mist or vapor is inhaled, go immediately to an area with fresh air. Cover up with a blanket. Stay warm and stable and seek professional medical advice.

#### Cautions regarding handling of SG-S700 OIL:

- Use appropriate eye protection when handling, and avoid contact with eyes. In the event of eye contact, flush with fresh water and seek medical assistance immediately. Contact with eyes may result in irritation.
- Use gloves when handling. In the event of skin contact, wash well with soapy water. Contact with skin may cause a rash and discomfort.
- Do not drink. If it is drunk by mistake, do not induce vomiting; make the affected person drink 1 to 2 cups of water and seek medical assistance immediately. If the affected person loses consciousness, do not give the person anything by their mouth. If vomiting occurs naturally, tilt the body to prevent inhalation.
- After use, be sure to wash hands thoroughly.
- Keep the container sealed to prevent foreign objects and moisture from getting inside, and store it in a cool, dark area away from direct sunlight.
- Keep out of reach of children.
- Dispose of used oil, old oil, or oil used for cleaning in accordance with the method stipulated by the law.
- In order to maintain proper performance, it is recommended that you replace the oil once a year from the start of use (or once about every 2,000 km if the bicycle is used very frequently).
- Do not use oil other than SG-S700 OIL. Problems such as an oil leakage and gear shifting malfunction may occur.
- Disposal of used oil: Follow local county and/or state codes for disposal. Use caution when preparing the oil for disposal.
- Read this manual carefully, and keep it in a safe place for later reference.
- For the latest product safety data sheets, check the website <https://si.shimano.com>.

#### TECH TIPS

When using a 1L can of oil, it may become impossible to suck out oil with a syringe when there is only a little oil left. First, transfer all oil to a different container.

▶ For internal 11-speed (oil maintenance kit: Y13098023)

## Internal geared hub: Oil replacement

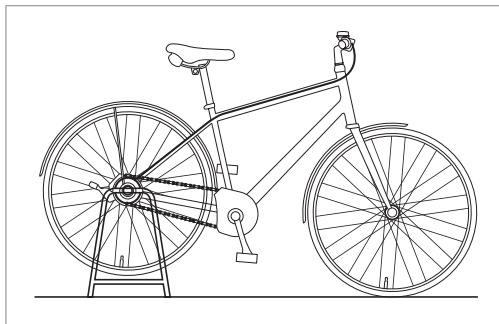

Using a stand, etc., enable the rear wheel to turn while performing work.

### Draining out the old oil

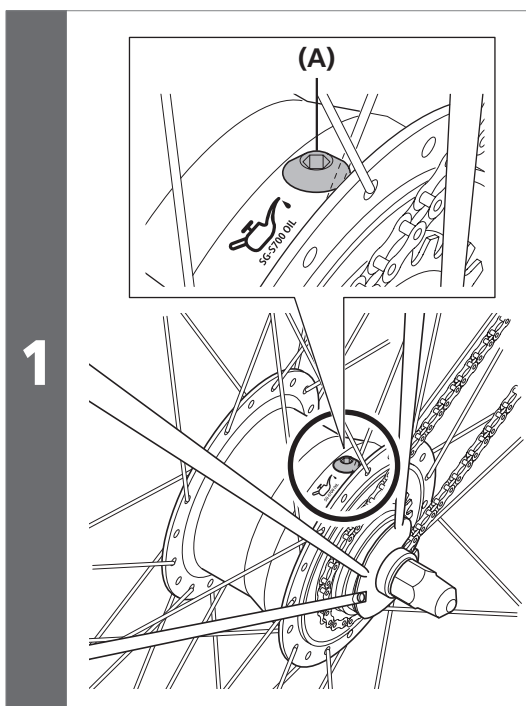

Rotate the wheel slowly until the oil port is facing up.

(A) Oil port

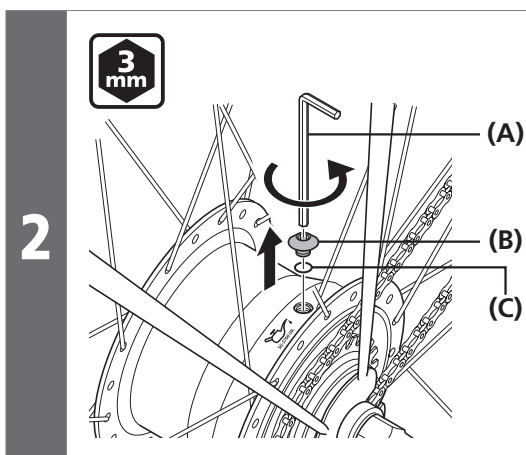

Remove the oil port screw and O-ring.

- (A) 3 mm hexagon wrench
- (B) Oil port screw
- (C) O-ring

#### NOTICE

Be careful that the oil port is facing up; if the oil port screw is loosened when it is not facing up, the oil inside may leak out.

▶ For internal 11-speed (oil maintenance kit: Y13098023)

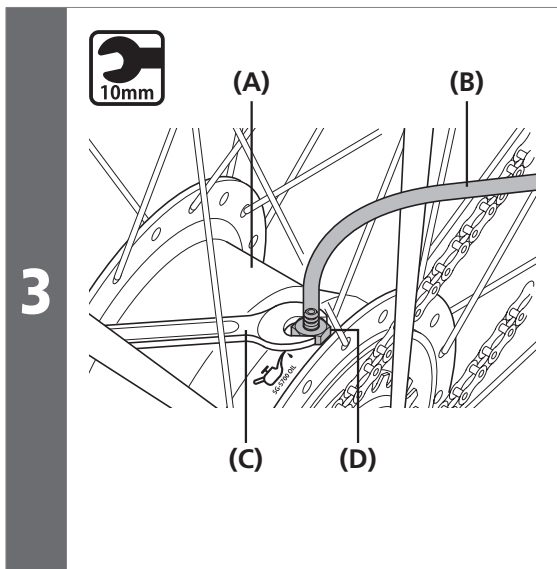

Attach the bleed nipple with tube attached to the hub shell.

- (A) Hub shell
- (B) Tube
- (C) 10 mm spanner
- (D) Bleed nipple

Tightening torque	
	1 - 3 N·m

**TECH TIPS**

Check that the O-ring is properly installed on the bleed nipple.

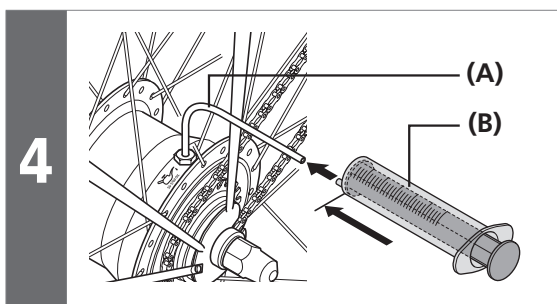

With the piston of the syringe pushed fully in, firmly connect the syringe to the tube.

- (A) Tube
- (B) Syringe

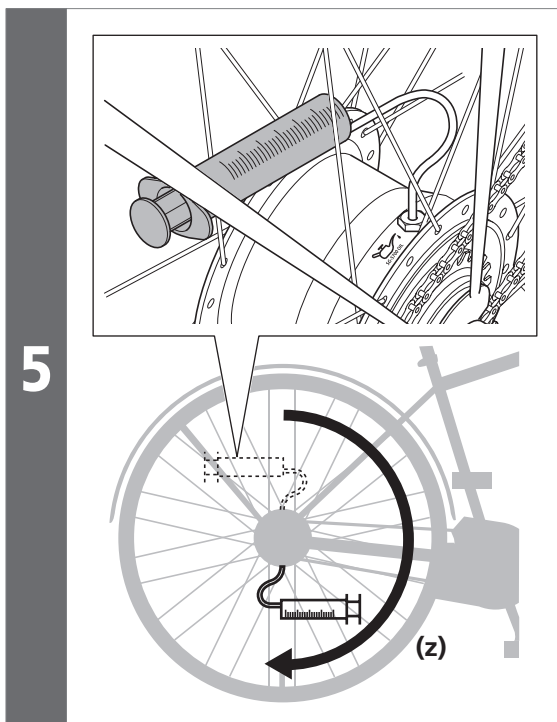

Insert the syringe between the spokes, and slowly turn the wheel forward until the oil port is facing down.

- (z) Turn in forward direction

**6** Wait about 5 minutes with the hub kept still and not turning so that the oil settles.

▶ For internal 11-speed (oil maintenance kit: Y13098023)

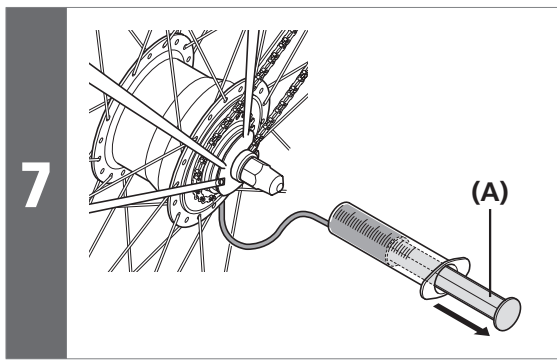

Pull the piston out slowly to draw out the oil inside the hub shell.

**(A)** Piston

**NOTICE**

If the piston is pulled out quickly, air is likely to be mixed in.

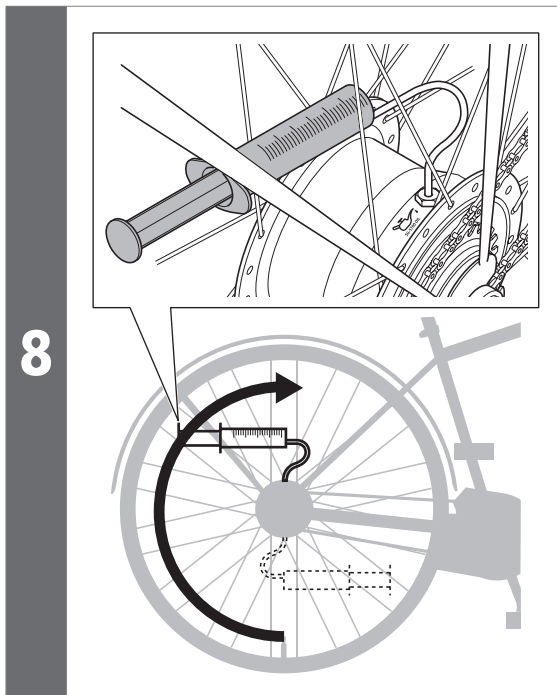

Rotate the wheel slowly until the oil port is facing up.

**NOTICE**

To make sure that the syringe does not get caught by the chain case, etc., store the syringe between the spokes when turning the wheel.

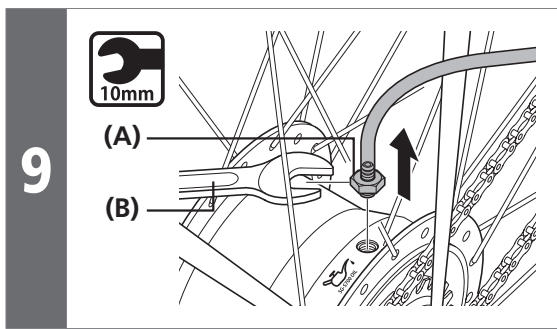

While being careful that the tube does not come off the syringe, remove the bleed nipple.

**(A)** Bleed nipple  
**(B)** 10 mm spanner

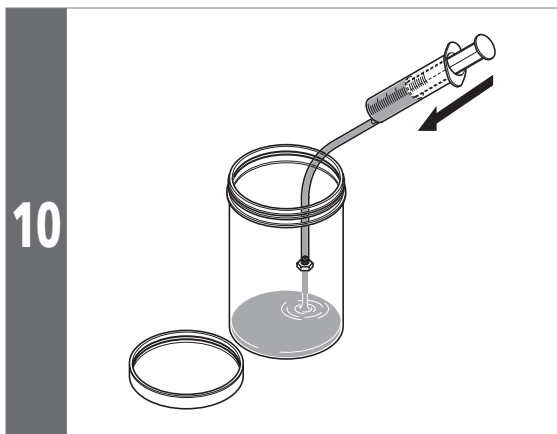

Remove the old oil from the syringe.

▶ For internal 11-speed (oil maintenance kit: Y13098023)

**Cleaning the inside**

**1** Attach the bleed nipple to the hub shell.

**2** Suck 25ml of new oil into the syringe and connect it firmly to the tube.

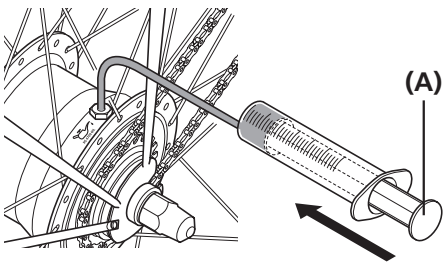
**3**  Push the piston to inject the new oil into the inside of the hub.

**4** After pulling back the piston to reduce the internal pressure, remove the bleed nipple.

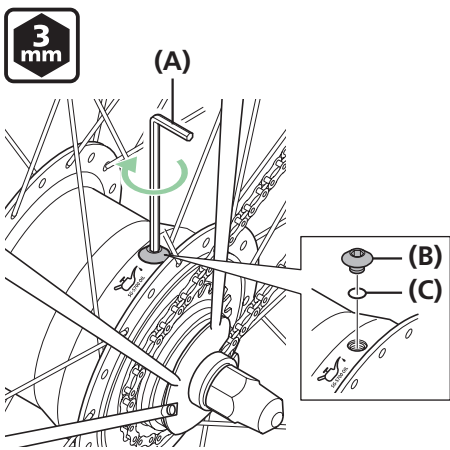
**5**  Install the O-ring and the oil port screw.

**Tightening torque**

	<b>1 - 3 N·m</b>
---	------------------

 **TECH TIPS**

If the syringe or tube becomes dirty when removing old oil or cleaning the inside of the hub, clean the syringe and tube using parts cleaner, etc., if necessary.

**(A)** Piston

 **TECH TIPS**

When the oil is forced in, the internal pressure will increase and the piston may push back. If the piston is periodically pulled back to reduce the pressure inside the hub, the oil will be easier to inject into the inside of the hub.

 **TECH TIPS**

If the bleed nipple is removed without pulling back the piston, the oil may flow back into the piston together with air from inside the tube and spill out of the piston.

- (A)** 3 mm hexagon wrench
- (B)** Oil port screw
- (C)** O-ring

**Tightening torque**

	<b>2 - 3 N·m</b>
---	------------------



▶▶ For internal 11-speed (oil maintenance kit: Y13098023)

**6** While performing gear-change operations, turn the pedals to turn the wheel for about 1 minute.

**7** Keep the wheel still without rotating for about 1 minute.

**8** Remove the oil from inside by following the procedures in **Draining out the old oil** above.

### **Injecting new oil**

**1** Inject 25ml of new oil into the hub by following steps **Cleaning the inside 1 - 5** above.

**2** Clean off any oil that may have gotten on the hub, etc.

# SHIMANO

**SHIMANO NORTH AMERICA BICYCLE, INC.**

One Holland, Irvine, California 92618, U.S.A. Phone: +1-949-951-5003

**SHIMANO EUROPE B.V.**

High Tech Campus 92, 5656 AG Eindhoven, The Netherlands Phone: +31-402-612222

**SHIMANO INC.**

3-77 Oimatsu-cho, Sakai-ku, Sakai City, Osaka 590-8577, Japan

Please note: specifications are subject to change for improvement without notice. (English)

© Jun. 2024 by SHIMANO INC. ITP