

## Dealer's Manual

ROAD	GRAVEL	MTB
E-BIKE	LIFESTYLE	GENERAL

# SHIMANO E-BIKE SYSTEMS CYCLE COMPUTER AND SWITCH UNIT PARTS (Gen.2)

### SHIMANO

SC-EN600

SC-EN610

SC-EN500

SW-EN600-L

SW-EN600-R

SW-EN605-R

SW-M8150

---

## Contents

<b>IMPORTANT NOTICE</b> .....	<b>4</b>
<b>TO ENSURE SAFETY</b> .....	<b>5</b>
<b>Booklet structure</b> .....	<b>8</b>
<b>List of tools to be used</b> .....	<b>10</b>
<b>Installation/removal</b> .....	<b>11</b>
SHIMANO E-BIKE SYSTEMS battery management systems and compatibility.....	11
Electric wires.....	12
• Supported products .....	12
• Conversion adapter .....	13
• Connecting/disconnecting the electric wires .....	13
Installing the cycle computer .....	17
• Clamp band type cycle computer .....	17
• Switch unit integrated type cycle computer .....	18
• Bracket installation type cycle computer .....	19
Installing the switch unit .....	24
• Wireless type switch unit .....	24
• MTB type switch unit .....	25
• 3-switch type switch unit .....	30
Wiring around the cockpit (clamp band type cycle computer).....	32
• Example: Routing the electric wire .....	32
Wiring around the cockpit (switch unit integrated type cycle computer) .....	35
• Example: Routing the electric wire .....	35
Wiring around the cockpit (bracket installation type cycle computer) .....	37
• Example: Routing the electric wire .....	37
Wiring around the cockpit (other cases) .....	40
<b>Connection and communication with devices</b> .....	<b>41</b>
Introduction .....	41
Connection with all SHIMANO E-BIKE SYSTEMS components .....	42
• Clamp band type cycle computer .....	42
• Switch unit integrated type cycle computer .....	42
• Bracket installation type cycle computer .....	43

---

Single component connection .....	44
Drive unit setting backup function .....	45
Maintenance alert.....	46
<b>Maintenance.....</b>	<b>47</b>
Replacing the coin batteries.....	47
• Before replacing the coin batteries .....	47
• Replacing the coin batteries (for the wireless type switch unit) .....	47
Replacing the clamp band.....	49
Gear shifting adjustment ([Adjust]) .....	51
• Notation method for operations .....	51
• Checking the setting value .....	52
• Adjusting when the setting value is [0] .....	52
• Adjusting when the setting value is not [0] .....	54
Time settings .....	55
<b>Troubleshooting .....</b>	<b>56</b>

# IMPORTANT NOTICE

- **This dealer's manual is intended primarily for use by professional bicycle mechanics.**

Users who are not professionally trained for bicycle assembly should not attempt to install the components themselves using the dealer's manuals.



If any part of the information on the manual is unclear to you, do not proceed with the installation. Instead, contact your place of purchase or a distributor for assistance.

- Make sure to read all manuals included with each product.
- Do not disassemble or modify the product other than as stated in the information contained in this dealer's manual.
- All manuals and technical documents are accessible online at <https://si.shimano.com>.
- For consumers who do not have easy access to the internet, please contact a SHIMANO distributor or any of the SHIMANO offices to obtain a hardcopy of the user's manual.
- Please observe the appropriate rules and regulations of the country, state or region in which you conduct your business as a dealer.
- The Bluetooth® word mark and logos are registered trademarks owned by the Bluetooth SIG, Inc. and any use of such marks by SHIMANO INC. is under license. Other trademarks and trade names are those of their respective owners.

**For safety, be sure to read this dealer's manual thoroughly before use, and follow it for correct use.**

The following instructions must be observed at all times in order to prevent personal injury and physical damage to equipment and surroundings.

The instructions are classified according to the degree of danger or damage which may occur if the product is used incorrectly.

 <b>DANGER</b>	Failure to follow the instructions will result in death or serious injury.
 <b>WARNING</b>	Failure to follow the instructions could result in death or serious injury.
 <b>CAUTION</b>	Failure to follow the instructions could cause personal injury or physical damage to equipment and surroundings.

# TO ENSURE SAFETY

## WARNING

- **Be sure to follow the instructions provided in the manuals when installing the product.**  
Only use SHIMANO genuine parts. If a component or replacement part is incorrectly assembled or adjusted, it can lead to component failure and cause the rider to lose control and crash.
-  Wear approved eye protection while performing maintenance tasks such as replacing components.
- For information on products not explained in this manual, refer to the manuals for each product.

### Be sure to also inform users of the following:

- Do not pay excessive attention to the cycle computer display while riding. Doing so may result in an accident.
- Ensure that head and tail lights can turn on before riding the bicycle.
- Do not disassemble the product. Disassembling may cause injury.
- For installation to the bicycle and maintenance
  - Be sure to remove the battery and charging cable before wiring or attaching parts to the bicycle. Failure to do so may cause an electric shock.
- Remarks regarding coin battery-compatible models
  - Do not disassemble or modify the product. This may cause the product to not operate correctly, and you may suddenly fall and be seriously injured.
  - Do not throw or subject the product to strong shock. If this is not observed, bursting, overheating or problems with operation may occur.
  - Do not let grease adhere to the metal terminals. A conduction failure may result.
  - Use only the coin batteries specified. When replacing the coin battery, replace both batteries at the same time with new ones. Using different kinds of coin batteries or new and old coin batteries together may cause the coin batteries to burst, leak fluid, overheat or catch fire, resulting in a fire, injuries or contamination in the surrounding area.
  - Coin batteries are hazardous and must be kept away from children. Never put coin batteries in mouth or in any part of the body. Severe or fatal injuries can occur within 2 hours if swallowed or placed inside the body. If this occurs or is suspected, seek medical attention immediately.



- Do not use this equipment in locations where children are likely to be present. If the included coin batteries are swallowed by mistake, seek medical attention immediately.
- Dispose of the coin batteries according to proper country and/or state disposal regulations. Disposal of this product into fire or a hot oven, or mechanically crushing or cutting it, can result in an explosion of the coin batteries.
- Do not use the coin batteries outside their operating temperature ranges. If a battery is used or stored in temperatures which are outside these ranges, fire, injury or problems with operation may occur.
- Do not use the coin batteries if leakages, discoloration, deformation or any other abnormalities occur. If this is not observed, bursting, overheating or problems with operation may occur.

- If any leaked fluid from the coin batteries gets on your skin or clothes, wash it off immediately with clean water. The leaked fluid may damage your skin.
- Do not leave this product in an extremely high temperature surrounding environment such as in a closed vehicle on a hot day, or near a heater. Doing so may result in an explosion of the coin batteries or the leakage of flammable liquid or gas from them.
- Do not subject this product to extremely low air pressure. Doing so may result in an explosion of the coin batteries or the leakage of flammable liquid or gas from them. Transporting this product by air is not a problem.

### **CAUTION**

Be sure to also inform users of the following:

- Observe the instructions in the manual for the bicycle in order to ride safely.
- Use the product under the supervision of someone responsible for safety, and only as instructed. Do not allow anyone (including children) with reduced physical, sensory, or mental capacity, or those without experience or knowledge, to use the product.
- Do not allow children to play near the product.
- If any malfunction or trouble occurs, consult the place of purchase.
- Never modify the system. Doing so may cause a system error.

### **NOTICE**

Be sure to also inform users of the following:

- Be sure to attach dummy plugs to any unused E-TUBE ports.
  - For installation and adjustment of the product, consult the place of purchase.
  - The components are designed to be fully waterproofed to withstand wet weather riding conditions. However, do not deliberately place them into water.
  - Do not clean the bicycle with a high-pressure wash. If water gets into any of the components, operating problems or rusting may result.
  - Handle the components carefully, and avoid subjecting them to strong shock.
  - Do not turn the bicycle upside down. There is a risk of damage to the cycle computer and switch unit.
  - Although the bicycle still functions as a normal bicycle even when the battery is removed, the light will not turn on if it is connected to the electric power system. Be aware that using the bicycle under these conditions will be considered non-observance of the road traffic laws in Germany.
  - Some of the important information in this dealer's manual can also be found on the device labels.
  - For any questions regarding methods of installation and maintenance, please contact your place of purchase.
  - Contact the place of purchase for updates of the component software. The most up-to-date information is available on the SHIMANO website. For details, refer to the "[Introduction](#)" section.
  - Products are not guaranteed against natural wear and deterioration from normal use and aging.
  - For details on inter-product compatibility, refer to the compatibility information on the SHIMANO product website ( <https://productinfo.shimano.com/#/com> ).
- Remarks regarding coin battery-compatible models
- Insert the coin batteries with the correct +/- orientation.
  - Remove the coin batteries if you do not use them for a long period.
  - When the coin batteries are depleted, remove them immediately.

- Store a coin battery-compatible product or a bicycle with a coin battery-compatible product installed in a cool indoor location away from direct sunlight and rain (approx. 10°C - 20°C). If the storage temperature is too low or too high, the performance of the coin batteries is reduced, and their usable time will be shorter. When using after a long period of non-use, be sure to replace the coin batteries with new ones.
- For maximum performance we highly recommend SHIMANO lubricants and maintenance products.

■ Connection and communication with PC

Using a PC linkage device to connect a PC to your bicycle (system or component) allows you to use E-TUBE PROJECT Professional to perform a range of tasks, such as customizing individual components or the entire system, or updating firmware.

- PC linkage device: SM-PCE02
- E-TUBE PROJECT Professional: PC application
- Firmware: Software inside each component

■ Connection and communication with smartphones (supported models only)

Connecting your bicycle (system or component) over Bluetooth<sup>®</sup> LE to a smartphone allows you to use E-TUBE PROJECT Cyclist to perform a range of tasks, such as customizing individual components or the system, or updating firmware.

- E-TUBE PROJECT Cyclist: Application for smartphones
- Firmware: Software inside each component

**The actual product may differ from the illustration because this manual is intended mainly to explain the procedures for using the product.**

# Booklet structure

## ■ User's manual

User's manuals for SHIMANO E-BIKE SYSTEMS are split among several booklets, as described below.

The latest manuals are available on our website ( <https://si.shimano.com> ).

Name	Details
<a href="#">SHIMANO E-BIKE SYSTEMS User's Manual</a>	This is the basic user's manual for SHIMANO E-BIKE SYSTEMS. It contains the following content: <ul style="list-style-type: none"> <li>• Quick guide</li> <li>• Basic operations when riding</li> <li>• How to operate assist bicycles that use flat handlebars, such as city, trekking, or MTB type bicycles</li> </ul>
<a href="#">SHIMANO E-BIKE SYSTEMS User's Manual for Drop Handlebar Bicycles</a>	This booklet describes how to operate assist bicycles that use a drop handlebar and are controlled using dual control levers. This should be read along with the SHIMANO E-BIKE SYSTEMS User's Manual.
SHIMANO E-BIKE SYSTEMS Special Battery and Parts User's Manual (Gen.2) ( <a href="#">standard type</a> / <a href="#">type supporting range extender from another company</a> )	It contains the following content: <ul style="list-style-type: none"> <li>• How to charge and handle the SHIMANO E-BIKE SYSTEMS special battery</li> <li>• How to attach and remove the SHIMANO E-BIKE SYSTEMS special battery to the bicycle</li> <li>• Using the satellite charging port</li> <li>• How to read the battery LEDs when charging or during an error</li> </ul>
SHIMANO E-BIKE SYSTEMS Cycle Computer User's Manual ( <a href="#">clamp band type</a> / <a href="#">bracket installation type</a> / <a href="#">switch unit integrated type</a> )	It contains the following content: <ul style="list-style-type: none"> <li>• Method for configuring settings via the main body buttons and switch unit</li> <li>• Wireless communication method (supported models only)</li> </ul>
Switch Unit User's Manual* ( <a href="#">with LED indicator function</a> / <a href="#">without LED indicator function</a> / <a href="#">wireless gear shifting type</a> )	This is the assist switch and shift switch user's manual. It describes switch unit handling and operations.
<a href="#">Satellite System ON/OFF Switch User's Manual</a>	It describes the handling and operations of the satellite system ON/OFF switch.

\* SHIMANO E-BIKE SYSTEMS compatibility with wireless gear shifting will be provided in a future firmware update.

## ■ Dealer's manual







Dealer's manuals for SHIMANO E-BIKE SYSTEMS are split among several booklets, as described below.

The latest manuals are available on our website ( <https://si.shimano.com> ).

Name	Details
<a href="#">SHIMANO E-BIKE SYSTEMS Dealer's Manual</a>	<p>This is the basic dealer's manual for SHIMANO E-BIKE SYSTEMS.</p> <ul style="list-style-type: none"> <li>• Overall wiring diagram</li> <li>• Overall flow of operations for installing the SHIMANO E-BIKE SYSTEMS components to an assist bicycle</li> <li>• Installation / removal and maintenance of the drive unit area</li> <li>• Installation / removal of the speed sensor</li> </ul>
<a href="#">SHIMANO E-BIKE SYSTEMS Dealer's Manual for Drop Handlebar Bicycles</a>	<p>It specializes in the following information regarding assist bicycles that use a drop handlebar and are controlled using dual control levers. This should be read along with the SHIMANO E-BIKE SYSTEMS Dealer's Manual.</p> <ul style="list-style-type: none"> <li>• Overall wiring diagram</li> <li>• Cautions to follow when installing the drive unit</li> </ul>
<p>SHIMANO E-BIKE SYSTEMS Special Battery and Parts Dealer's Manual (Gen.2) ( <a href="#">standard type</a> / <a href="#">type supporting range extender from another company</a> )</p>	<p>It contains the following content:</p> <ul style="list-style-type: none"> <li>• How to install the battery mount</li> <li>• How to install the satellite system ON/OFF switch and satellite charging port</li> </ul>
<p><a href="#">SHIMANO E-BIKE SYSTEMS Cycle Computer and Switch Unit Parts Dealer's Manual (Gen.2)</a> (this manual)</p>	<p>It contains the following content:</p> <ul style="list-style-type: none"> <li>• Installation and maintenance of the SHIMANO E-BIKE SYSTEMS special cycle computer and switch unit</li> <li>• How to connect to E-TUBE PROJECT Professional</li> </ul>
<a href="#">SHIMANO E-BIKE SYSTEMS Chain Device Dealer's Manual</a>	<p>This manual describes the installation and maintenance of the SHIMANO E-BIKE SYSTEMS special chain device.</p>

# List of tools to be used

The following tools are needed for installation/removal, adjustment, and maintenance purposes.

Tool	
	TL-EW02
	TL-EW300
	Cross head screwdriver [#1]
	Cross head screwdriver [#2]
	2 mm hexagon wrench
	2.5 mm hexagon wrench
	3 mm hexagon wrench
	4 mm hexagon wrench

# Installation/removal

## SHIMANO E-BIKE SYSTEMS battery management systems and compatibility

There are two generations of the SHIMANO E-BIKE SYSTEMS battery management system: first generation and second generation (Gen.2).

This manual only describes products compatible with Gen.2.

With some exceptions, first-generation and Gen.2 products of SHIMANO E-BIKE SYSTEMS components are not compatible with each other. For details, refer to the compatibility information on the SHIMANO product website (<https://productinfo.shimano.com/#/com>).

The Gen.2 battery and compatible battery mount are marked "Gen.2" as indicated in the figure.

Example: BT-EN805 and compatible battery mount

Location of terminals

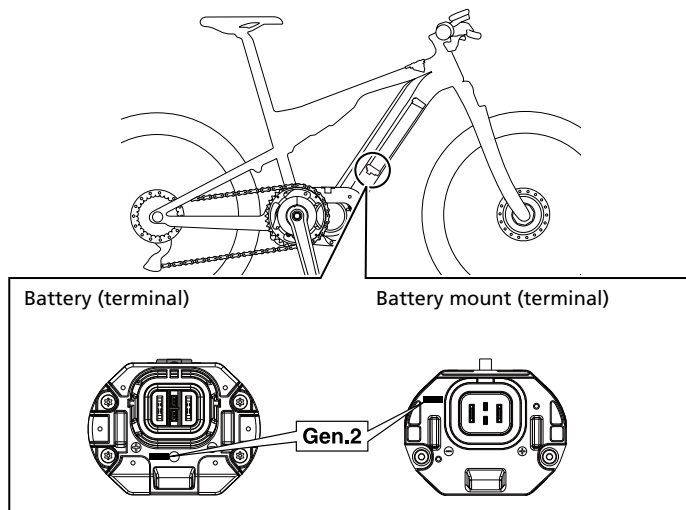

# Electric wires

There are two types of electric wire: the EW-SD300 and the EW-SD50. The supported electric wire differs based on the component model. Check the component specifications on the SHIMANO product website in advance (<https://productinfo.shimano.com/>).

## Supported products

The following products support each type of electric wire.

Product name	Intended purpose	EW-SD300 type	EW-SD50 type
SHIMANO original tool	Connecting / disconnecting the electric wires	TL-EW300	TL-EW02
Dummy plug	Plugging empty ports	Y7HE30000	Y6VE15000
Cord clip	Binding the wiring and the outer casing / brake hose together	EW-CL300-S (for shift outer casing) EW-CL300-M (for outer casing and brake hose)	Y70H98040
Cord cover	Supporting / protecting the electric wire (external wiring)	EW-CC300	SM-EWC2
Grommet	Installing to the wire insertion hole of a frame that supports internal wiring	EW-GM300-S EW-GM300-M	SM-GM01 SM-GM02
Cord band	Supporting the electric wire (flat handlebar external wiring)	EW-CB300-S EW-CB300-M EW-CB300-L	SM-EWE1
Junction [A] (for Di2)	Gathering the wiring around the cockpit. Also has functions for changing the shift mode, etc.	-	EW-RS910 SM-EW90-A SM-EW90-B
Junction [B]	Conjoining the wiring inside and outside the frame	EW-JC304 EW-JC302	SM-JC41 SM-JC40 EW-JC200 EW-JC130
Conversion adapter	Refer to the " <a href="#">Conversion adapter</a> " section	EW-AD305	EW-AD305

**NOTICE**

- The SHIMANO original tool used for installation/removal and the accessories used for wiring differ for the EW-SD300 and EW-SD50. Be sure to use a compatible product.
- EW-CL300-S is marked with a groove in order to differentiate it from EW-CL300-M.

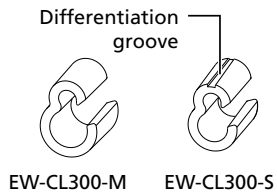

## Conversion adapter

A conversion adapter (EW-AD305) is required to connect the EW-SD50 to a component with an E-TUBE port for the EW-SD300.

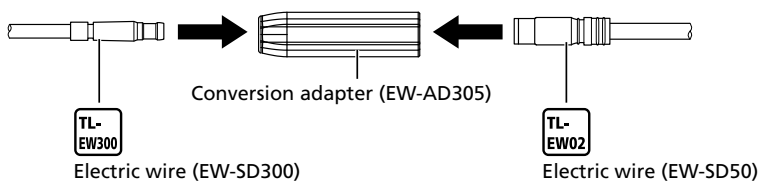

## Connecting/disconnecting the electric wires

Be sure to use the SHIMANO original tool to remove and install the electric wires.

### NOTICE

- When connecting and disconnecting electric wires, do not forcibly bend the plug part. It may result in a poor connection.

## Connecting the electric wire (EW-SD300)

Connect the electric wire to the E-TUBE port.

### 1. Set the plug of the electric wire to the TL-EW300.

If there is an alignment tab on the plug of the electric wire, check the shape of the E-TUBE port you are trying to connect to, and set it aligned with the alignment tab as shown in the figure.

Without alignment tab on plug

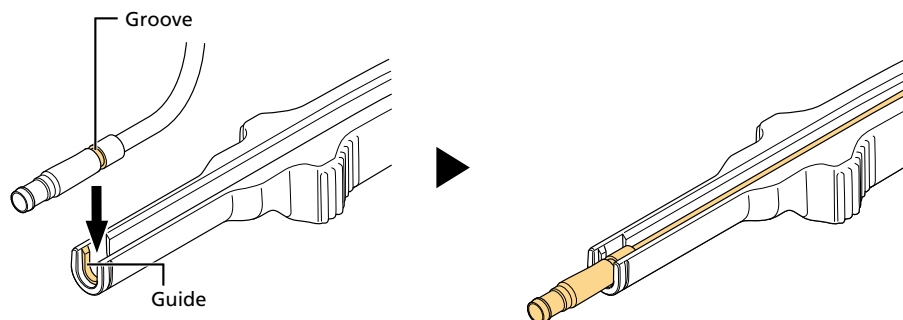

With alignment tab on plug

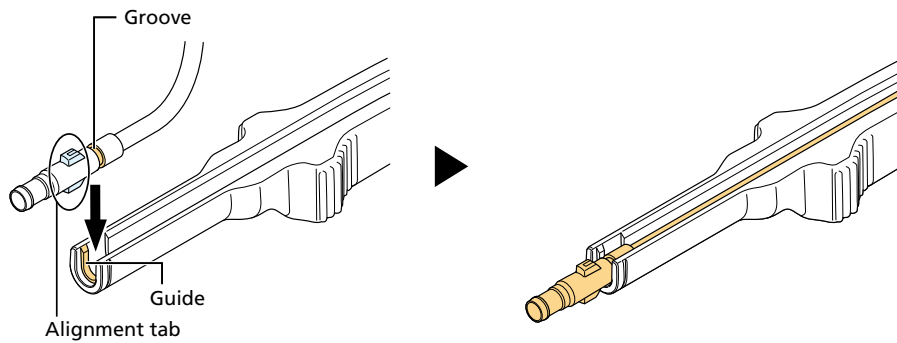

**2. Insert the plug on the electric wire into the E-TUBE port.**

Push it straight in until you feel a click.

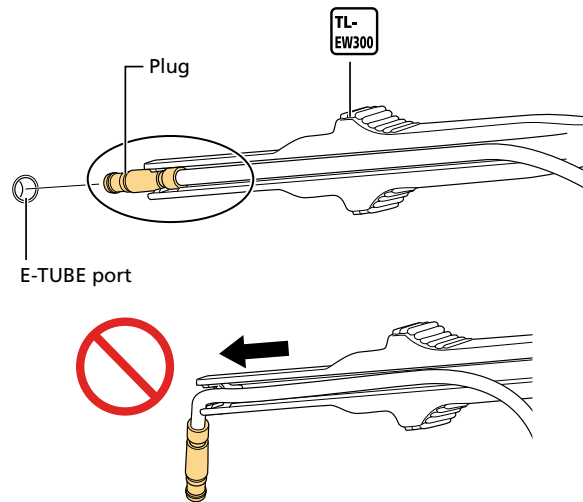

**TECH TIPS**

- When connecting the EW-SD300, the method below can also be used.

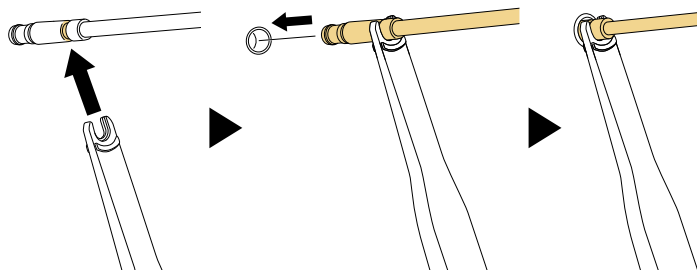

**Removing the electric wire (EW-SD300)**

**1. Disconnect the electric wire.**

- (1) Insert the TL-EW300 into the groove on the plug part of the electric wire.
- (2) Disconnect the electric wire from the E-TUBE port.

\* As shown in the figure, use part (A) of the TL-EW300 as a fulcrum, move the tool like a lever, then disconnect the plug part.

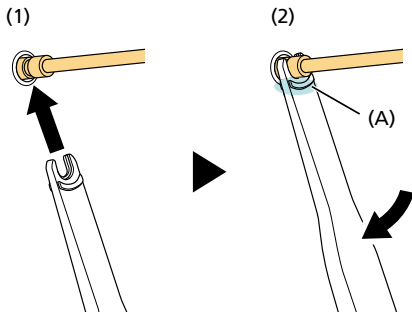

### TECH TIPS

- If there is limited space to insert the tool, you can use the TL-EW300 as indicated in the figure to disconnect the electric wire.

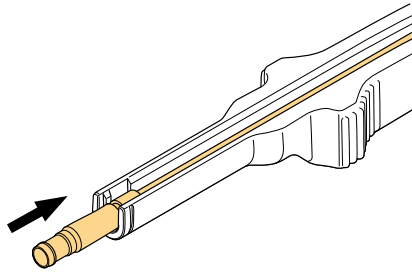

## Connecting the electric wire (EW-SD50)

Connect the electric wire to the E-TUBE port.

### 1. Set the plug of the electric wire to the TL-EW02.

If there is an alignment tab on the plug of the electric wire, set it aligned with the groove on the SHIMANO original tool.

Without alignment tab on plug

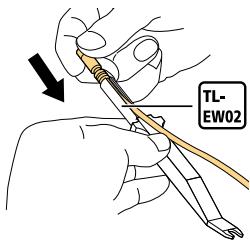

With alignment tab on plug

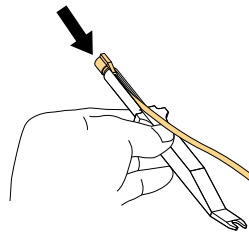

### 2. Insert the plug on the electric wire into the E-TUBE port.

Push it straight in until you feel a click.

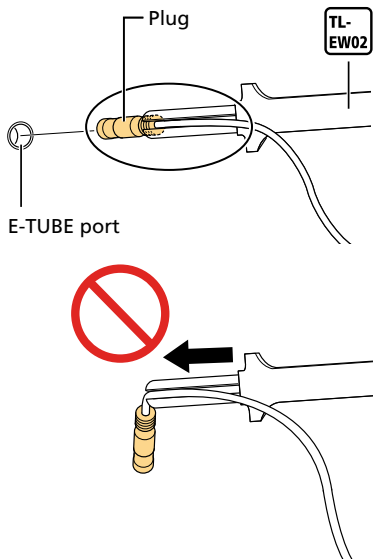

## Removing the electric wire (EW-SD50)

### 1. Disconnect the electric wire.

- (1) Insert the TL-EW02 into the groove on the plug of the electric wire.
- (2) Disconnect the electric wire from the E-TUBE port.

\* As shown in the figure, use part (A) of the TL-EW02 as a fulcrum, move the tool like a lever, then disconnect the plug part. If there is limited space to insert the tool, lift the TL-EW02 straight up and disconnect the electric wire.

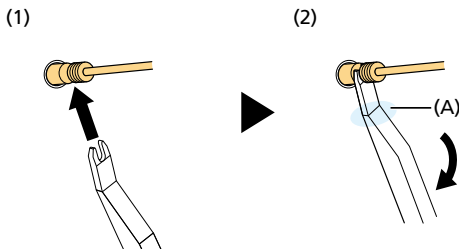

# Installing the cycle computer

## Clamp band type cycle computer

For model: SC-EN600

### Installation to the handlebar

SC-EN600 can be installed to  $\text{Ø}35.0$  and  $\text{Ø}31.8$  handlebars.

#### 1. Pass the cycle computer's clamp band around the handlebar.

Insert it from the right side of the handlebar and install it near the right side of the stem.

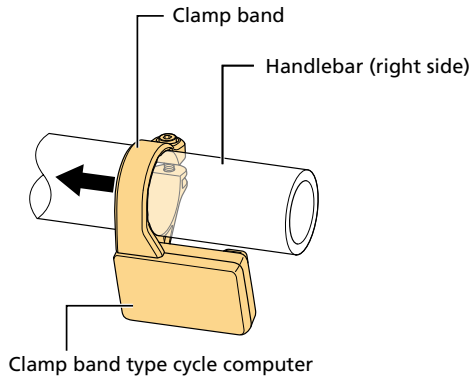

#### 2. Adjust the installation angle, and secure the cycle computer to the handlebar.

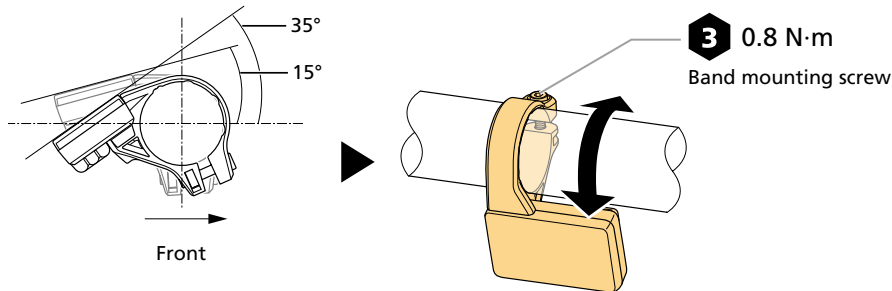

### Built-in installation to the handlebar/stem

Built-in installation of a clamp band type cycle computer is possible in a stem integrated type handlebar, etc. In many cases, the procedure involves installing a cycle computer with electric wires connected in advance to the handlebar. Install it with the SHIMANO logo on the right when facing the front of the bicycle, and secure it from the rear.

#### Built-in installation to the stem integrated type handlebar and wiring example

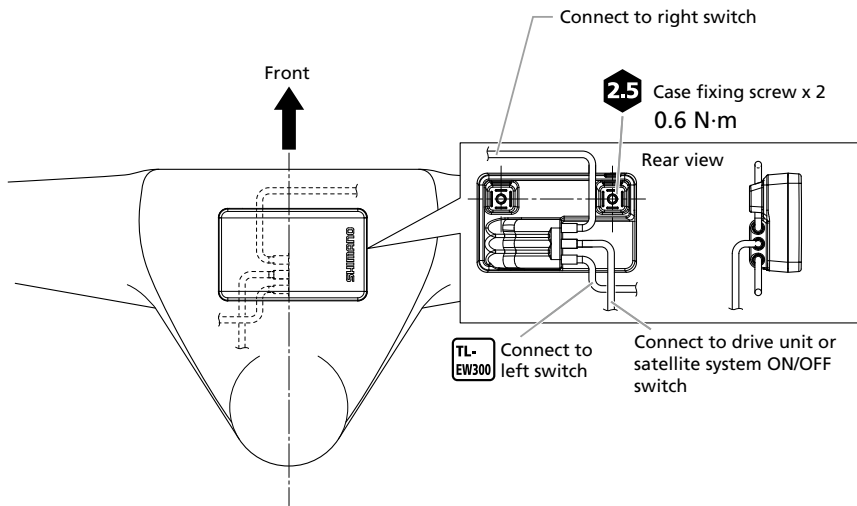

- When performing installation, make sure to refer to the manual of the assist bicycle or handlebar compatible with built-in installation.
- Make sure to use the case fixing screws provided by the manufacturer of the handlebar or assist bicycle. Screws of an inappropriate length may damage the cycle computer or have insufficient holding force.
- Be careful not to apply excessive force to or bend the brake hose or electric wires.

## Switch unit integrated type cycle computer

For model: SC-EN500

It can be installed to  $\varnothing 22.2$  handlebars.

### 1. Pass the cycle computer's clamp band around the handlebar.

Insert it from the left side of the handlebar and install it near the handlebar grip to enable easy operations of the switch part.

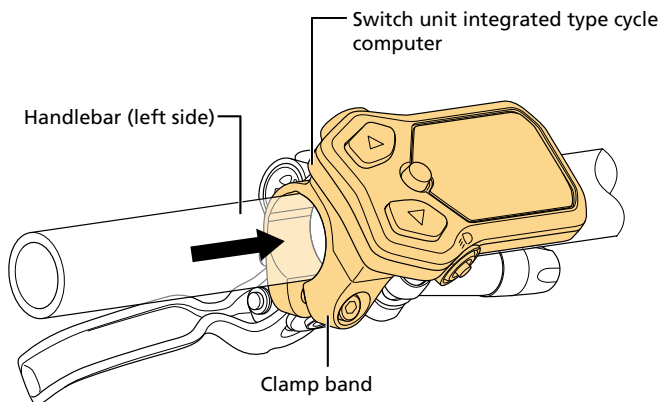

**NOTICE**

- The SC-EN500 (regular model) cannot be used in combination with an I-SPEC EV brake lever. This is because the main body of the SC-EN500 will interfere with the band of the brake lever. To avoid interference with the I-SPEC EV brake lever, combine the I-SPEC EV compatible type (SC-EN500-A) as indicated in the figure below.

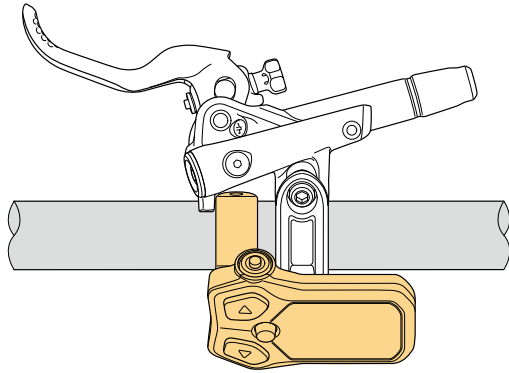

**2. Adjust the installation angle, and secure the cycle computer to the handlebar.**

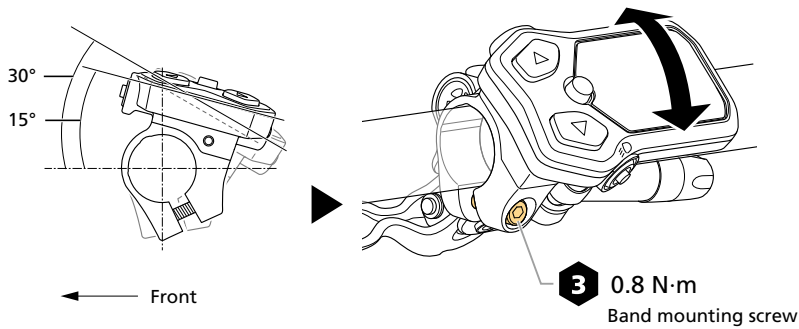

## Bracket installation type cycle computer

For model: SC-EN610

The bracket used to secure the cycle computer to the handlebar, and the cycle computer itself are separate parts.

### Installation layout

A bracket installation type cycle computer can be installed to the handlebar with layouts like those indicated in the figures.

When placing the cycle computer on the stem

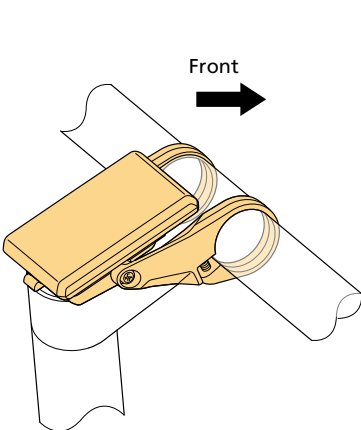

When placing the cycle computer on the front of the handlebar

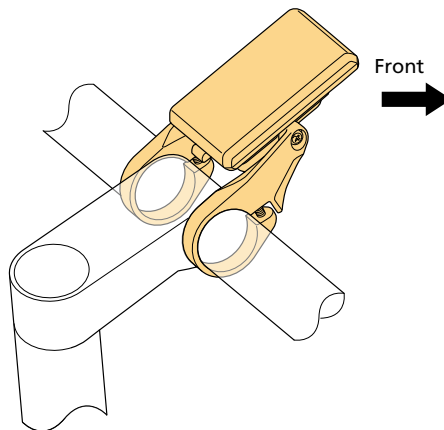

The procedure from here describes an example of placing the cycle computer on a stem such as that indicated in the figure on the left.

## TECH TIPS

- Using the installation layout with the cycle computer installed on the front of the handlebar is recommended for bicycles with drop handlebars.

## Installing the bracket and cycle computer

### 1. Check the diameter of the handlebar to determine whether an adapter is needed.

Install the bracket that supports the cycle computer in the position shown in the figure below.

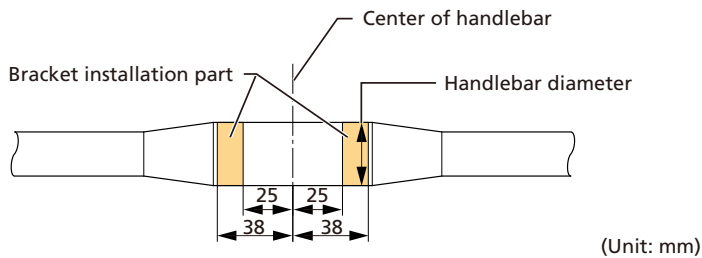

Handlebar diameter of stem installation area (mm)	Adapter
Ø25.2 - 25.6	Required
Ø31.6 - 32.0	Not necessary
Ø34.8 - 35.2	Not necessary

### 2. If adapters are required, push them along to the center of the handlebar.

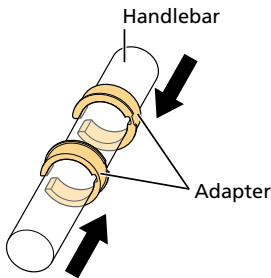

### 3. Temporarily install the bracket.

- Push the clamp area open, then install the bracket to the center of the handlebar.
- Temporarily install the mounting screws.

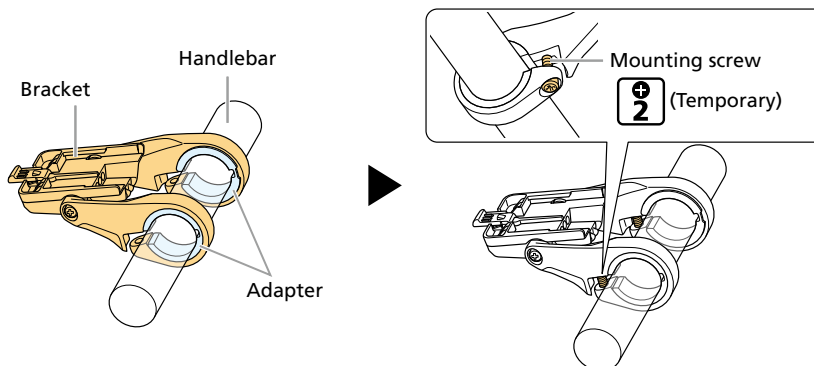

#### 4. Install the cycle computer to the bracket.

Slide the cycle computer and install it to the bracket.

Be sure to push it in firmly until you feel a click.

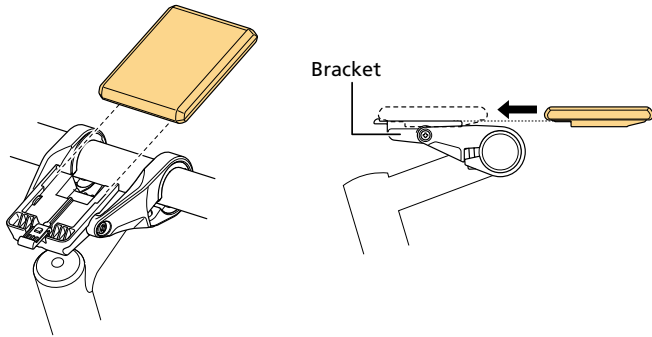

#### 5. Secure the cycle computer to the bracket if necessary.

If the cycle computer will not be secured to the bracket, this step is not necessary.

- (1) Stand the cycle computer and bracket up on the stem (as though you are turning the cycle computer around).
- (2) Tighten the security screw.

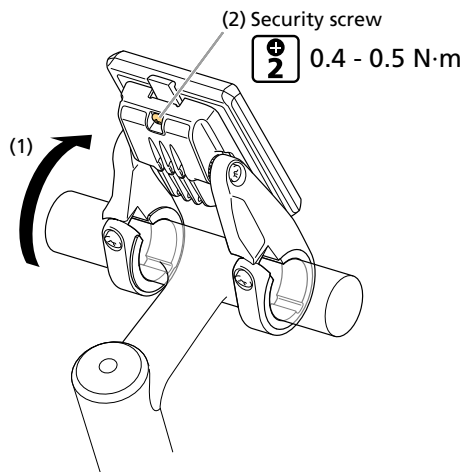

### TECH TIPS

- This procedure is used to secure the cycle computer to the bracket, so that it cannot be easily removed. This is useful for displaying the product on a sales floor.
- Ask the customer if they will secure the cycle computer when the product is delivered. If necessary, explain how to do so (as described above).

#### 6. Secure the bracket to the handlebar.

- (1) Return the cycle computer to its installation position if the cycle computer was stood up on the stem in [step 5](#).
- (2) Secure the bracket.

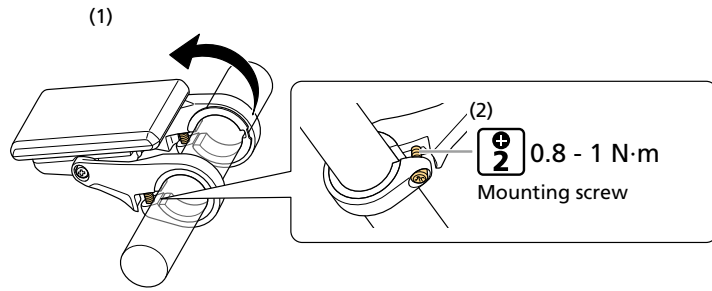

## Adjusting the installation angle

### 1. Adjust the installation angle of the cycle computer.

- (1) Loosen the angle adjustment screw.
- (2) After adjusting the angle of the cycle computer to make it easier to see while riding, tighten the angle adjustment screw.

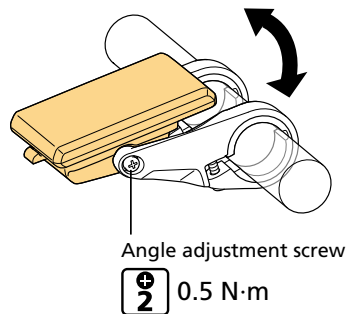

## Removing the cycle computer

### 1. Loosen the security screw on the bottom side of the bracket.

If the cycle computer was not secured, this procedure is not necessary. Skip to step [2](#).

- (1) Loosen the mounting screws, then stand the cycle computer and bracket up on the stem (as though you are turning the cycle computer around).
- (2) Loosen the security screw.

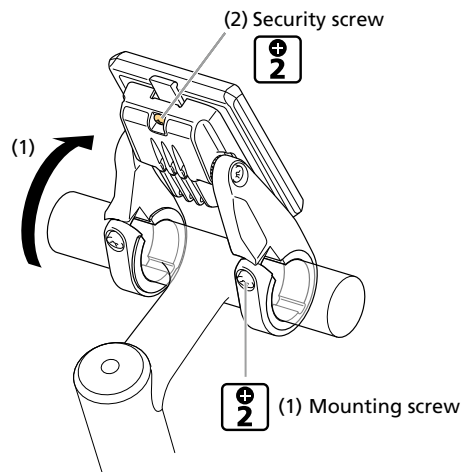

### 2. Remove the cycle computer from the bracket.

Slide the cycle computer to the front while pushing the bracket lever down to remove it.

Installation/removal  
Installing the cycle computer

---

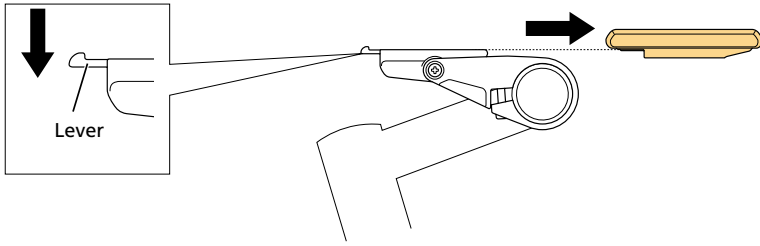

# Installing the switch unit

Install the assist switch and shift switch (for electronic gear shifting) to the handlebar.

When installing parts onto a carbon frame/handlebar, confirm the recommended tightening torque with the carbon frame or handlebar manufacturer. This will prevent damage to the frame/handlebar due to over-torquing or inadequate securing of the components.

## TECH TIPS

- To remove the switch unit, reverse the following procedure.

## Wireless type switch unit

For model: SW-EN605-R

The wireless type switch unit can be installed to a  $\text{Ø}22.2$  handlebar.

Before installing the switch unit, refer to the [user's manual for E-TUBE PROJECT Cyclist](#) or the dealer's manual for the [rear derailleur](#) / [motor unit](#) to pair and pair it in advance.

## NOTICE

- Do not operate another switch unit while pairing. Doing so may cause an unintended combination of products to be paired.
- Do not turn on the power of a bicycle with a rear derailleur/motor unit that has not been paired while pairing. Doing so may cause an unintended combination of products to be paired.
- After pairing, operate the switch unit to confirm that the paired products function normally.
- If an unintended combination of products is paired, cancel pairing in E-TUBE PROJECT, then perform pairing again. For details on canceling pairing, see the following:

[E-TUBE PROJECT Professional User's Manual](#)

[E-TUBE PROJECT Cyclist User's Manual](#)

### 1. Tighten the mounting screw.

Use a handlebar grip with a maximum outer diameter of  $\text{Ø}36$  mm or less.

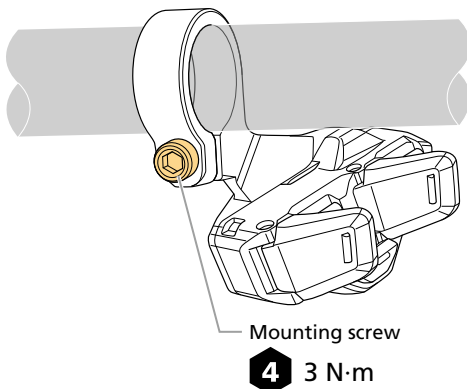

## NOTICE

- Confirm that the components installed to the handlebar, such as the brake lever and switch unit, do not interfere with each other and hinder operation.

## MTB type switch unit

For model: SW-M8150

- The MTB type switch unit can be installed to  $\text{Ø}22.2$  handlebars.

### Standard type

#### 1. Tighten the mounting screw.

Use a handlebar grip with a maximum outer diameter of  $\text{Ø}36$  mm or less.

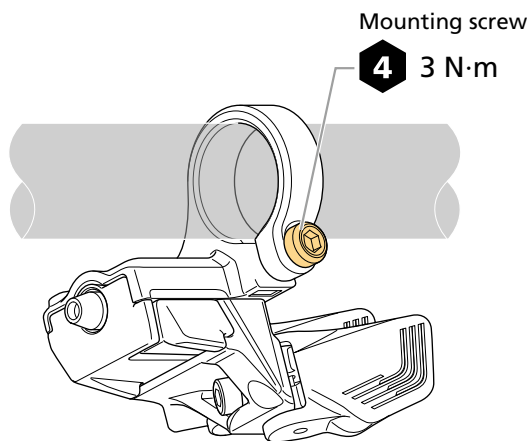

## NOTICE

- Confirm that the components installed to the handlebar, such as the brake lever and switch unit, do not interfere with each other and hinder operation.

#### 2. Adjust the installation angles of lever X and lever Y as required.

- (1) Loosen the lever fixing screws.
- (2) Adjust the installation angles of lever X and lever Y.
- (3) Tighten the lever fixing screws.

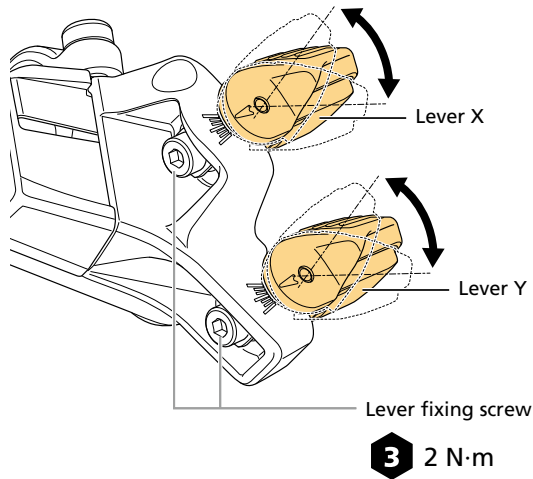

**3. Set the plug cover over the electric wire.**

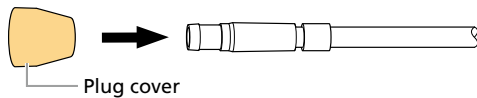

**4. Connect the electric wire.**

After connecting the electric wire, slide the plug cover over it.

When internally routing the wire through the handlebar, refer to the manual of the assist bicycle or handlebar.

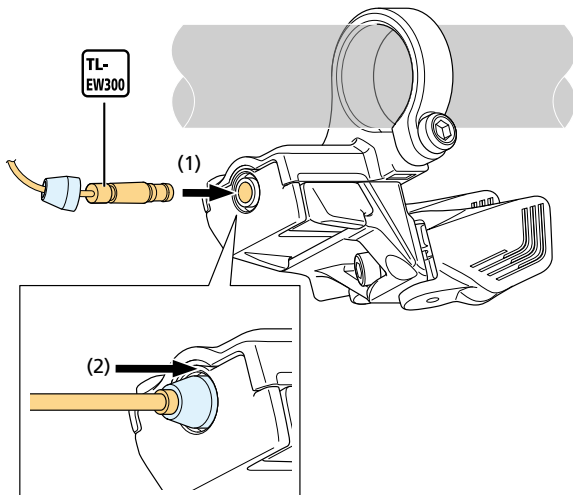

## I-SPEC EV

For information on brake levers that can be installed, check the compatibility information (<https://productinfo.shimano.com/#/com>).

**1. Open the clamp band of the brake lever.**

- (1) Loosen the mounting screw.
- (2) Press the recessed area of the clamp band with a tool such as a 2 mm hexagon wrench to disengage the safety latch.

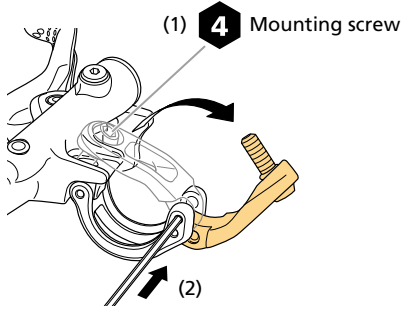

**2. Temporarily attach the switch unit to the clamp band.**

Temporarily install with the unit position adjustment bolt as shown in the figure.  
Make sure to firmly install the unit position adjustment nut to the clamp band.

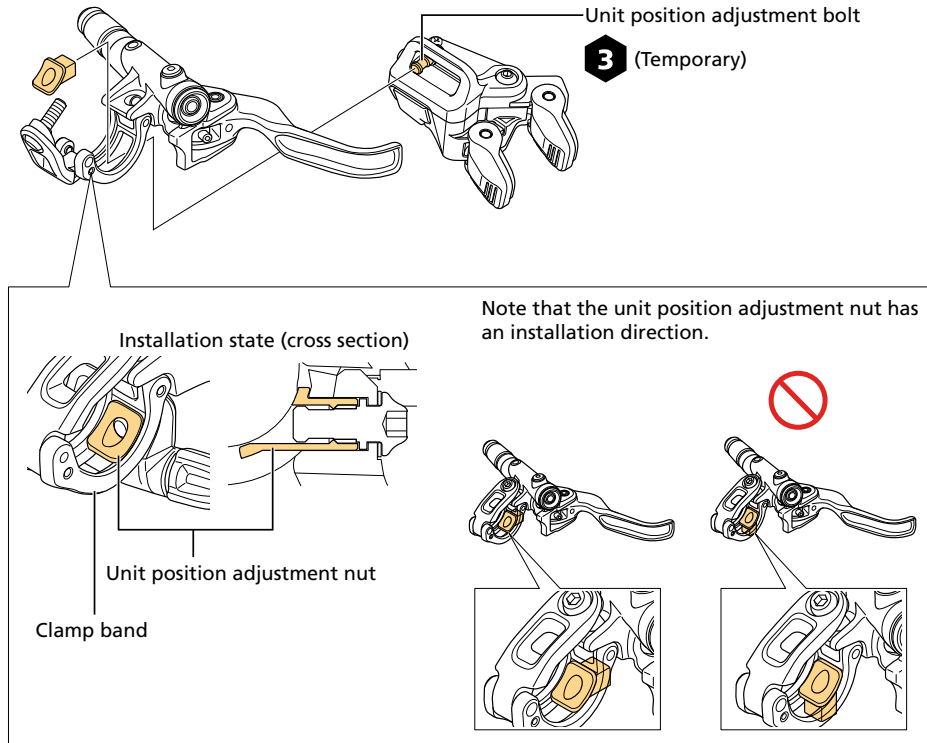

**3. Push an O-ring against the clamp band, as shown in the figure.**

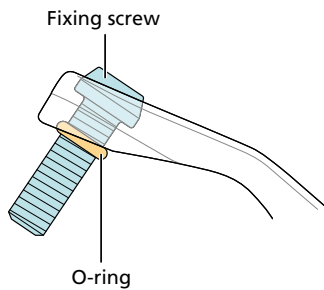

**4. Install the brake lever to the handlebar.**

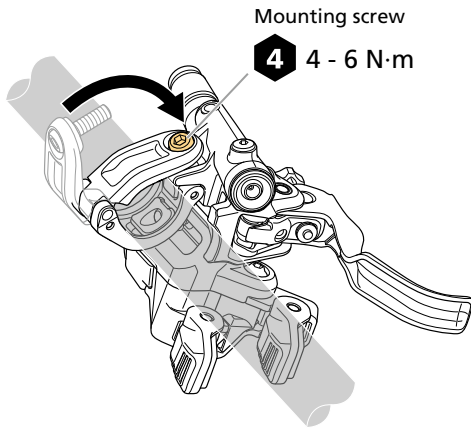

**5. Adjust the position of the switch unit.**

Slide the switch unit horizontally and vertically to adjust it.

If it is difficult to slide, loosen the unit position adjustment bolt.

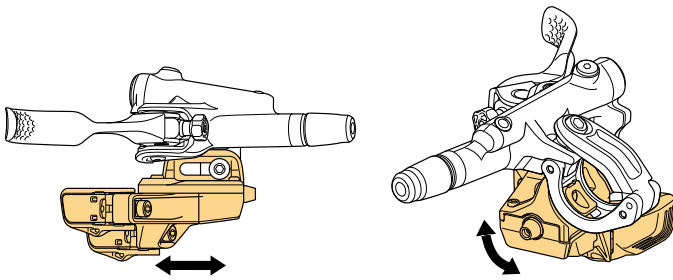

**TECH TIPS**

- To remove the switch unit, loosen the unit position adjustment bolt while pulling the main body of the switch unit away from the brake lever. Since the thread of the unit position adjustment bolt is cut off midway to prevent detachment, it is necessary to pull the main body of the switch unit away from the brake lever.

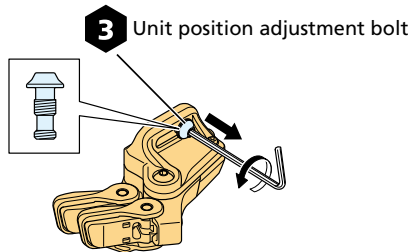

**6. Secure the switch unit.**

Unit position adjustment bolt

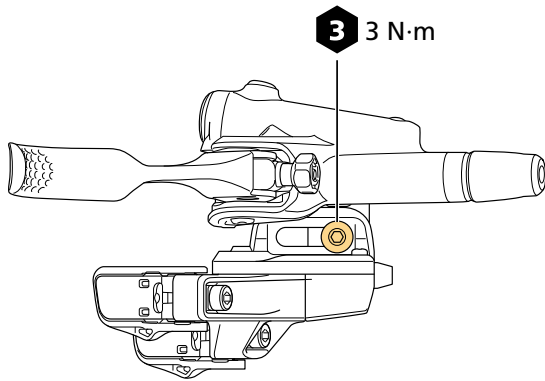

**7. Adjust the installation angles of lever X and lever Y as required.**

- (1) Loosen the lever fixing screws.
- (2) Adjust the installation angles of lever X and lever Y.
- (3) Tighten the lever fixing screws.

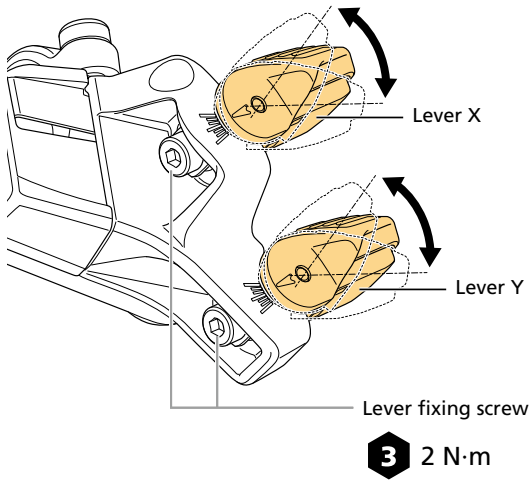

**8. Set the plug cover over the electric wire.**

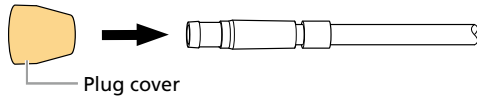

**9. Connect the electric wire.**

After connecting the electric wire, slide the plug cover over it.

When internally routing the wire through the handlebar, refer to the manual of the assist bicycle or handlebar.

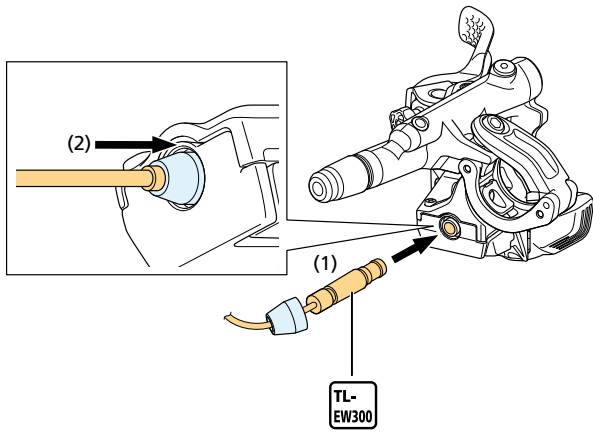

## 3-switch type switch unit

For models: SW-EN600-L, SW-EN600-R

The 3-switch type switch unit can be installed to a  $\text{Ø}22.2$  handlebar. This section explains the installation method when wiring from the switch unit along the handlebar on the outside.

### 1. Connect the electric wire.

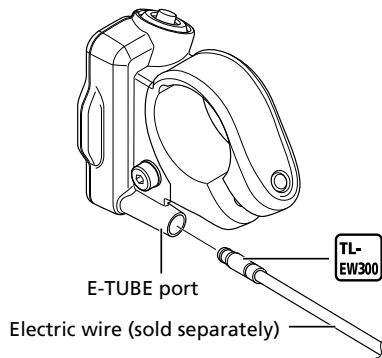

### 2. Slide the cord bands over the electric wire.

Adjust the number of cord bands according to the length of the handlebar.

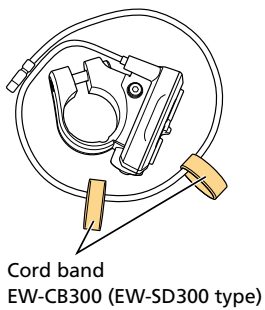

### 3. Push the cord bands and switch unit along from the edge of the handlebar.

Make sure the electric wire of the switch unit is facing downward.

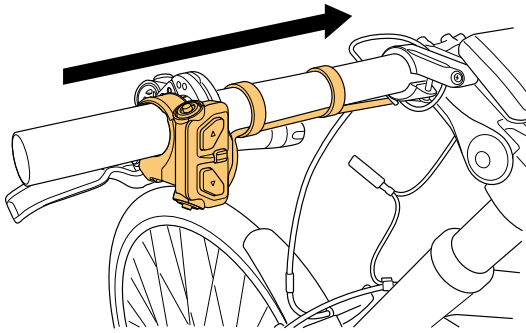

4. Secure the switch unit to the handlebar.

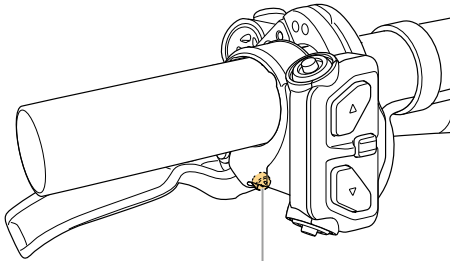

**3** 0.8 N·m  
Mounting screw

### **NOTICE**

- Combine the I-SPEC EV brake lever as indicated in the figure when performing installation.

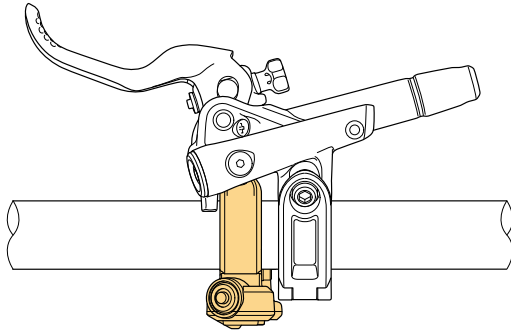

# Wiring around the cockpit (clamp band type cycle computer)

For model: SC-EN600

As an example, this section explains how to connect two switch units.

## NOTICE

- Be sure to attach dummy plugs to any unused E-TUBE ports.

### 1. Wire around the cockpit.

- Connect the cycle computer and the switch units using the electric wires. For the wireless gear shifting type, wiring is not required between the right switch and cycle computer.
- A switch unit, satellite system ON/OFF switch, or drive unit can be connected to any of the E-TUBE ports on the cycle computer. However, it is recommended to connect as shown in the figure.

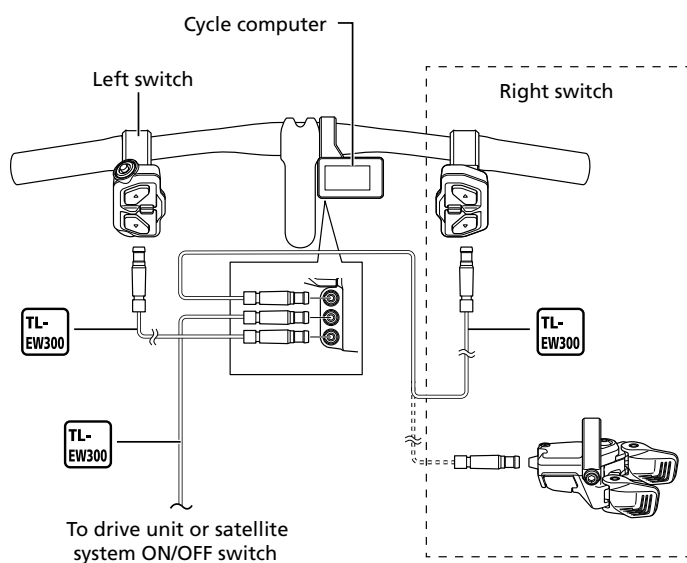

### 2. Prepare to wire to the drive unit.

Refer to the [SHIMANO E-BIKE SYSTEMS Dealer's Manual](#) when directly connecting to a drive unit.

Refer to the SHIMANO E-BIKE SYSTEMS Special Battery and Parts Dealer's Manual ( [standard type](#) / [type supporting range extender from another company](#) ) when connecting to a satellite system ON/OFF switch.

## Example: Routing the electric wire

Use cord bands and a cord clip to organize the wiring around the cockpit.

### When using cord bands

#### 1. Secure the switch unit's electric wire.

Determine the locations of the cord bands, then secure the electric wire in place along the handlebar so that there is no slack.

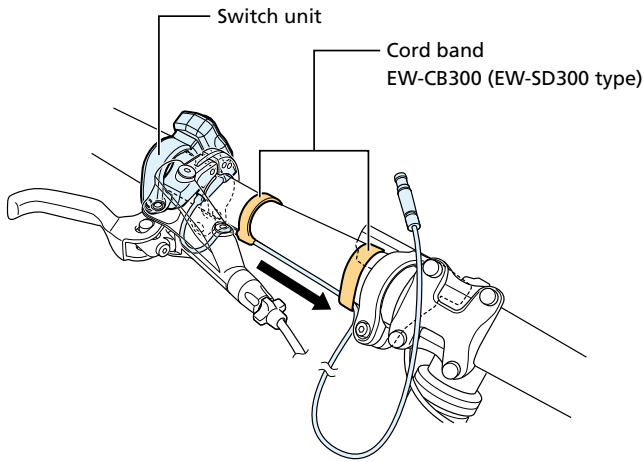

**2. Connect the electric wire to the E-TUBE port.**

Wrap any slack around the portion of the handlebar between the cycle computer and stem prior to connecting.

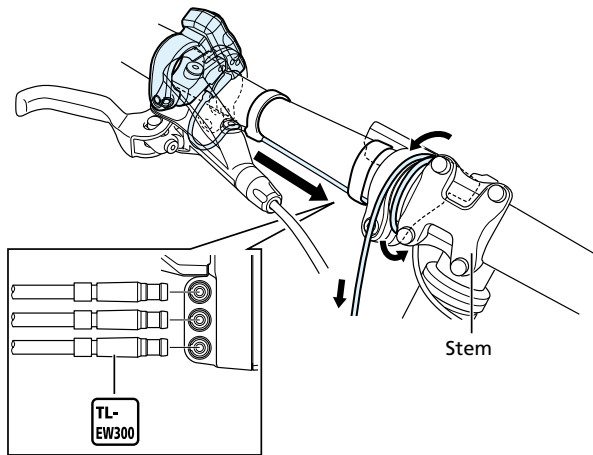

**When using cord bands and a cord clip**

**1. Secure the switch unit's electric wire.**

Determine the locations of the cord bands, then secure the electric wire in place along the handlebar so that there is no slack.

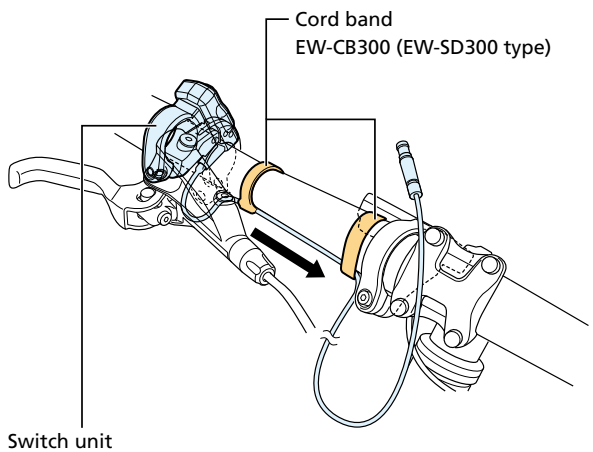

**2. Bind the electric wires and the brake outer casing or brake hose together with a cord clip.**

Use a cord clip to bind the brake outer casing or brake hose and the following electric wires:

- Switch unit's electric wire

- Electric wire to connect the cycle computer and drive unit

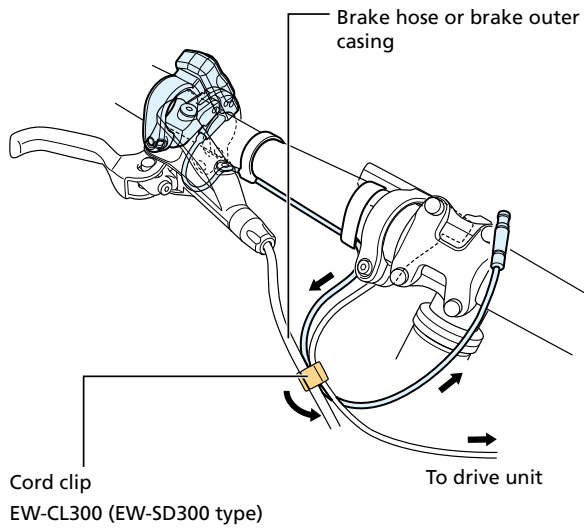

**3. Connect the electric wire to the E-TUBE port of the cycle computer.**

Wrap any slack around the portion of the handlebar between the cycle computer and stem prior to connecting.

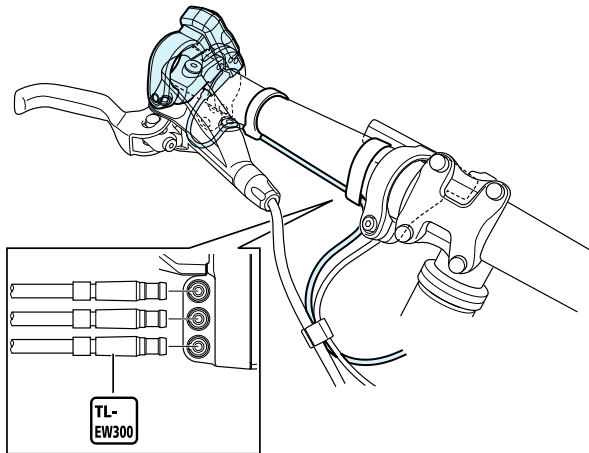

# Wiring around the cockpit (switch unit integrated type cycle computer)

For model: SC-EN500

As an example, this section explains how to connect a switch unit.

## NOTICE

- Be sure to attach dummy plugs to any unused E-TUBE ports.

### 1. Wire around the cockpit.

- Connect the cycle computer and the switch unit using the electric wires. For the wireless gear shifting type, wiring is not required between the right switch and cycle computer.

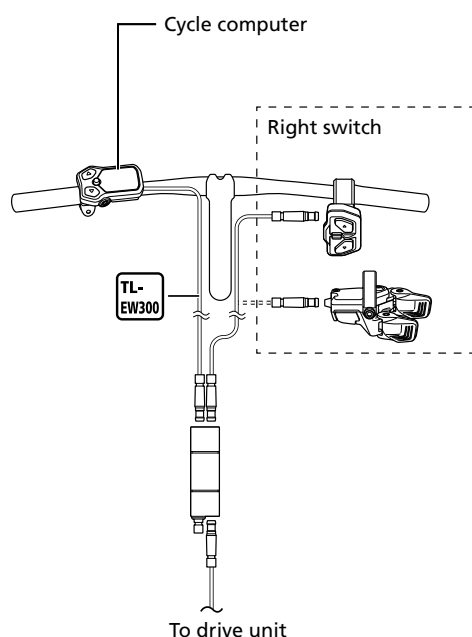

### 2. Prepare to wire to the drive unit.

Refer to the [SHIMANO E-BIKE SYSTEMS Dealer's Manual](#) when directly connecting to a drive unit.

Refer to the SHIMANO E-BIKE SYSTEMS Special Battery and Parts Dealer's Manual ( [standard type](#) / [type supporting range extender from another company](#) ) when connecting to a satellite system ON/OFF switch.

## Example: Routing the electric wire

When using cord bands, the electric wire connected to the cycle computer can be secured along the handlebar. The same applies when connecting the switch unit to the right side of the handlebar.

Installation/removal  
Wiring around the cockpit (switch unit integrated type cycle computer)

---

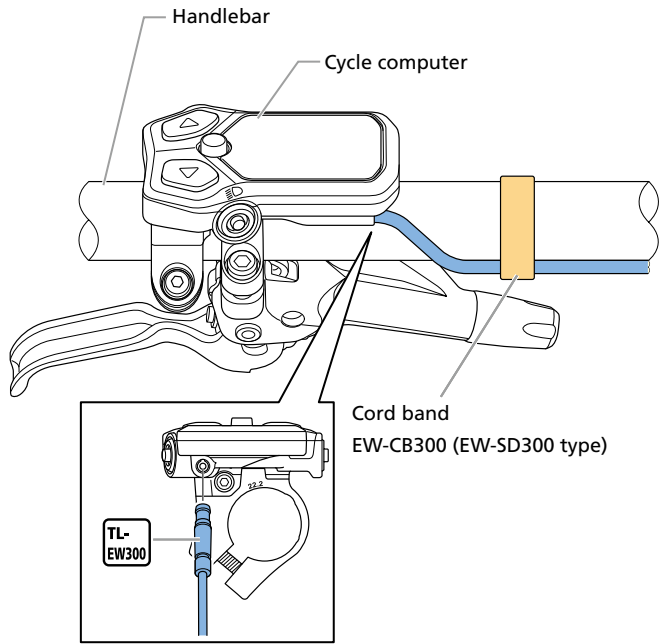

# Wiring around the cockpit (bracket installation type cycle computer)

For model: SC-EN610

As an example, this section explains how to connect two switch units.

## NOTICE

- Be sure to attach dummy plugs to any unused E-TUBE ports.

### 1. Wire around the cockpit.

- Connect the cycle computer and the switch units using the electric wires. For the wireless gear shifting type, wiring is not required between the right switch and cycle computer.
- Switch units and drive units can be connected to any of the E-TUBE ports on the cycle computer. However, it is recommended to connect the left and right ports to each switch unit, and the center port to the cycle computer (as shown in the figure).

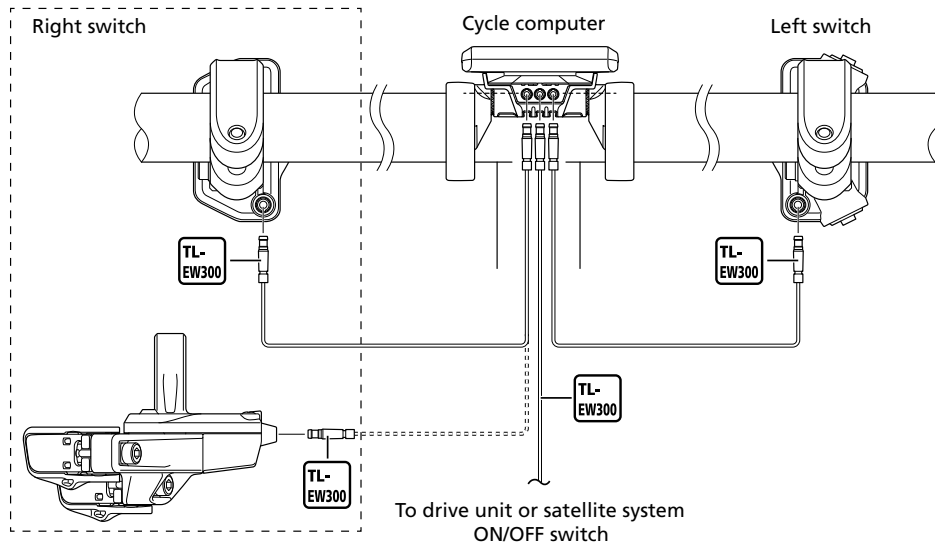

### 2. Prepare to wire to the drive unit.

Refer to the [SHIMANO E-BIKE SYSTEMS Dealer's Manual](#) when directly connecting to a drive unit.

Refer to the SHIMANO E-BIKE SYSTEMS Special Battery and Parts Dealer's Manual ( [standard type](#) / [type supporting range extender from another company](#) ) when connecting to a satellite system ON/OFF switch.

## Example: Routing the electric wire

Use cord bands and a cord clip to organize the wiring around the cockpit.

### When using cord bands

#### 1. Secure the switch unit's electric wire.

Determine the locations of the cord bands, then secure the electric wire in place along the handlebar so that there is no slack.

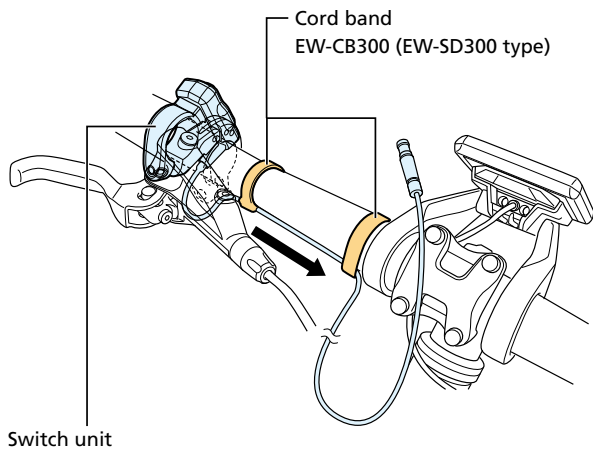

**2. Connect the electric wire to the E-TUBE port on the bracket.**

Wrap any slack around the portion of the handlebar between the cycle computer and stem prior to connecting.

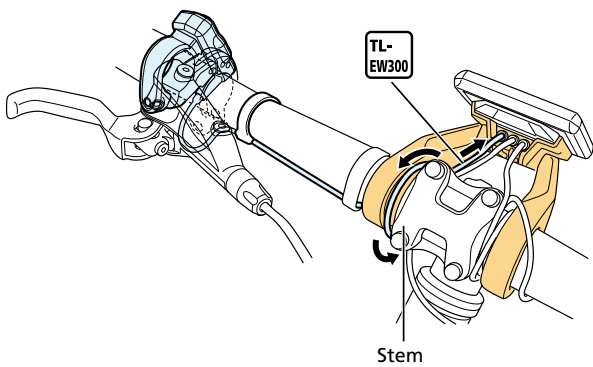

## When using cord bands and a cord clip

**1. Secure the switch unit's electric wire.**

Determine the locations of the cord bands, then secure the electric wire in place along the handlebar so that there is no slack.

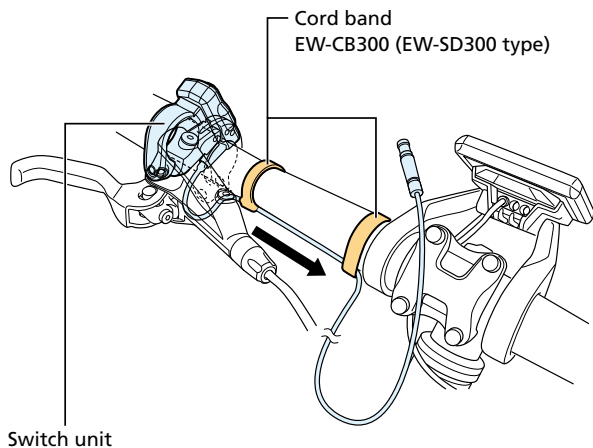

**2. Bind the electric wires and the brake outer casing or brake hose together with a cord clip.**

Use a cord clip to bind the brake outer casing or brake hose and the following electric wires:

- Switch unit's electric wire
- Electric wire to connect the cycle computer and drive unit

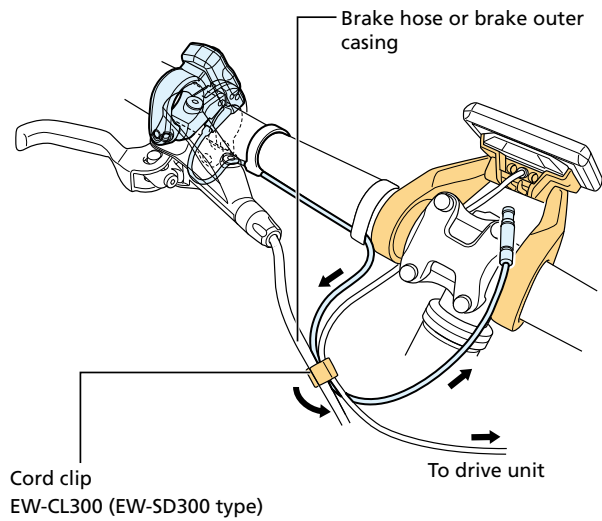

**3. Connect the electric wire to the E-TUBE port on the bracket.**

Wrap any slack around the portion of the handlebar between the cycle computer and stem prior to connecting.

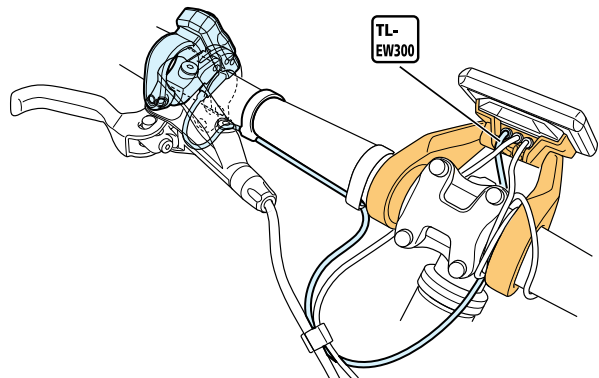

## Wiring around the cockpit (other cases)

A cockpit configuration such as the following may be used, depending on the bicycle. For the wireless gear shifting type, wiring is not required from the right switch.

### Example of configuration without cycle computer

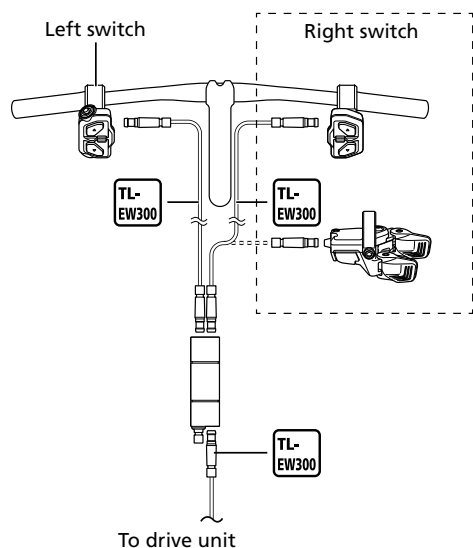

### Example of configuration without cycle computer and left switch

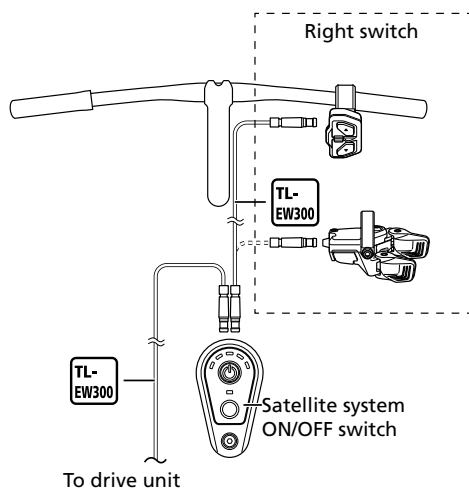

\* Refer to the SHIMANO E-BIKE SYSTEMS Special Battery and Parts Dealer's Manual ( [standard type](#) / [type supporting range extender from another company](#) ) for information on the satellite system ON/OFF switch.

# Connection and communication with devices

## Introduction

Connecting the bicycle to a device allows you to configure SHIMANO E-BIKE SYSTEMS and update firmware. E-TUBE PROJECT is needed to configure SHIMANO E-BIKE SYSTEMS and to update firmware.

Download E-TUBE PROJECT from our support website ( <https://bike.shimano.com/e-tube/project.html> ).

For information on how to install E-TUBE PROJECT, check the support website.

This manual describes how to connect to E-TUBE PROJECT Professional. Components that support Bluetooth<sup>®</sup> can also be operated via E-TUBE PROJECT Cyclist by wirelessly connecting to a smartphone. Refer to the user's manual.

### **NOTICE**

- PC connection and communication are not possible when charging the battery. Do not connect to a device while the battery is being charged.

### **TECH TIPS**

- The wireless type switch unit must be paired with a rear derailleur/motor unit. For details on pairing, refer to the following:
  - [E-TUBE PROJECT Professional User's Manual](#)
  - [E-TUBE PROJECT Cyclist User's Manual](#)
  - Dealer's manual for the rear derailleur or motor unit that will be paired
- A wireless type switch unit is not compatible with firmware updates and setting changes via E-TUBE PROJECT. However, it can be used to perform gear shifting adjustment via the adjustment function.
- When a connection is established between E-TUBE PROJECT and the cycle computer or all SHIMANO E-BIKE SYSTEMS components, the SHIMANO E-BIKE SYSTEMS logo or E-TUBE is displayed on the screen of the cycle computer.
- The PC linkage device is needed to connect SHIMANO E-BIKE SYSTEMS to a PC. Junction [B] will be needed in the following situations:
  - When there are no free E-TUBE ports on the cycle computer
  - When the configuration without cycle computer is applied
- If the PC link cable included with the SM-PCE02 is not the EW-SD300 type, use a conversion adapter (EW-AD305) to connect the wire to the EW-SD300. The EW-SD300 type PC link cable can be purchased as a service part.
- Firmware is subject to change without notice.

# Connection with all SHIMANO E-BIKE SYSTEMS components

To connect all SHIMANO E-BIKE SYSTEMS components installed to the assist bicycle, connect the cycle computer to the PC.

## Clamp band type cycle computer

Refer to the figure when connecting.

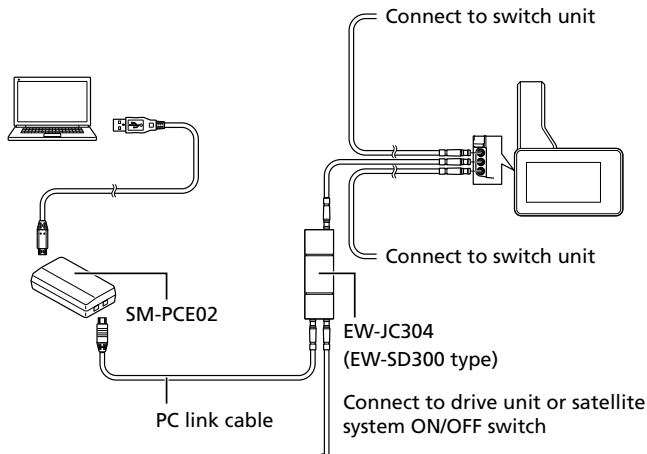

## Switch unit integrated type cycle computer

Refer to the figure when connecting.

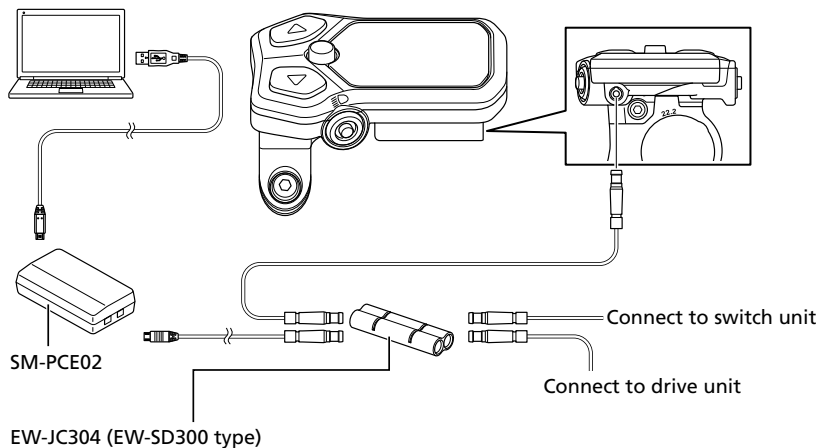

### TECH TIPS

- If the left switch of a bicycle without a cycle computer is the SW-EN600-L, the SW-EN600-L can be connected to the part of the cycle computer indicated in the figure to connect with the SHIMANO E-BIKE SYSTEMS components of the entire bicycle.

## Bracket installation type cycle computer

Refer to the figure when connecting.

### With free port

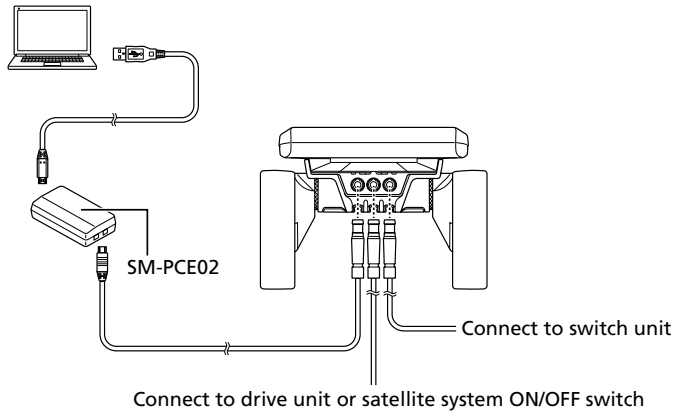

### Without free port

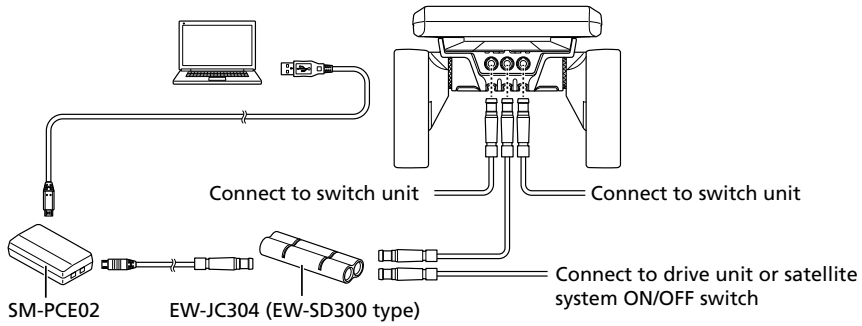

# Single component connection

Disconnect the wires of each component from the E-TUBE port, and connect to the PC via the PC linkage device.

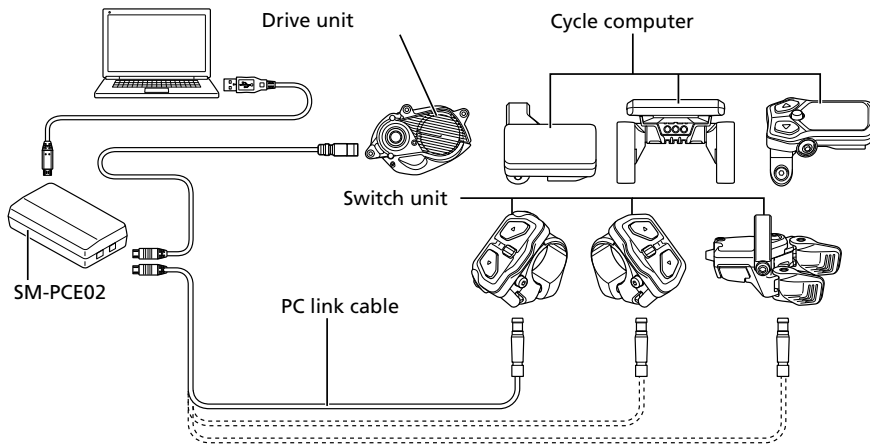

## TECH TIPS

- If the PC link cable included with the SM-PCE02 is not the EW-SD300 type, use a conversion adapter (EW-AD305) to connect the wire to the EW-SD300. The EW-SD300 type PC link cable can be purchased as a service part.
- Refer to the [SHIMANO E-BIKE SYSTEMS Dealer's Manual](#) for information on the E-TUBE ports of the drive unit.

# Drive unit setting backup function

To check the drive unit settings backed up to the cycle computer, export a PDF report from the E-TUBE PROJECT [Unit log acquisition] menu. When exchanging the drive unit, send the report along with the drive unit to the distributor from which the unit was purchased.

## Maintenance alert

This notifies the user that the bicycle requires maintenance. An icon is displayed on the cycle computer screen when the bicycle reaches the set odometer or date. You must connect to E-TUBE PROJECT to set maintenance alerts. For details, refer to the user's manual for E-TUBE PROJECT.

# Maintenance

## Replacing the coin batteries

### Before replacing the coin batteries

- The included coin batteries are for test purposes. When the coin battery level becomes low, replace the coin batteries with new ones.
- When replacing the battery or installing/removing the battery holder, move to an area well away from sources of water (such as rivers, lakes, the ocean, or ditches).
- Do not perform this task in locations with a lot of water or mud, such as outdoors during rain or car washing facilities. If not observed, problems with operation may occur.
- Do not perform this task in areas with a lot of sand or dust in the air. If not observed, problems with operation may occur.
- Before replacing the coin batteries, wipe the battery holder and battery case to remove water, dirt, etc. If not observed, problems with operation may occur.
- Use your hands or an insulated tool with a blunt tip to replace the coin batteries.
- Take care of the terminals when removing the coin batteries in order to prevent damage to the coin batteries.
- When performing this task with your hands, clean your hands and remove all water and dirt.
- Static electricity can damage electronic components. Discharge static electricity from your body before performing this task.
- Use CR1632 coin batteries. The number required differs depending on the model.
- It is recommended that you use new coin batteries.

### Replacing the coin batteries (for the wireless type switch unit)

For model: SW-EN605-R

#### 1. Remove the battery holder, then remove the two old coin batteries from the battery case.

If it is difficult to remove a coin battery, affix tape, etc. to the surface of the coin battery and pull it out.

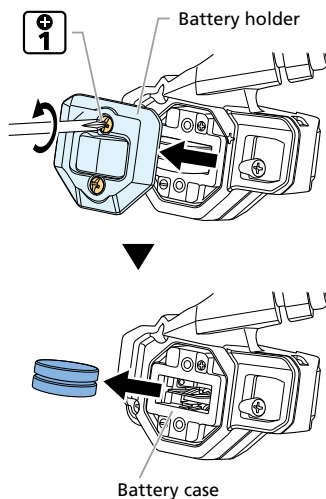

#### 2. Set the new coin batteries to the battery case.

As shown in the figure, insert the two coin batteries with the positive (+) side on the side of the + mark

(facing up).

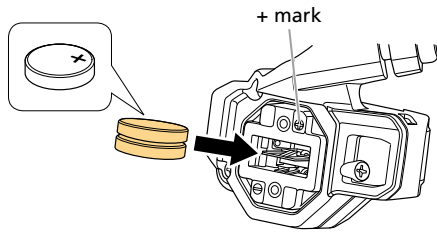

**3. Install the battery holder with the correct orientation, and firmly secure it.**

Be careful not to overtighten the battery holder fixing screws, as doing so may cause damage.

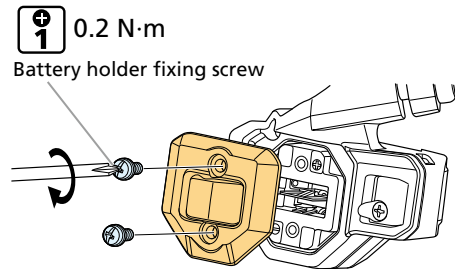

**NOTICE**

- Before installing the battery holder, check that the waterproof sealing gasket and contacting surfaces are free of foreign substances (such as dirt, dust, sand, hair, thread, or liquids).
- If there are foreign substances present, wipe them away with a clean, dry, and lint-free cloth.
- Remove the battery holder only when replacing the coin batteries, and do not leave it removed. Doing so may cause problems with operation due to foreign objects getting inside or deterioration to the electronic component, etc.
- Make sure the coin batteries are installed correctly. Installing a coin battery with the positive (+) and negative (-) polarities reversed will not only stop the component from operating, it may also cause the component to malfunction.
- After replacement, check that it works normally.

# Replacing the clamp band

For models: SC-EN600, SC-EN500, SW-EN600-L, SW-EN600-R

## 1. Remove the clamp band.

Clamp band type cycle computer

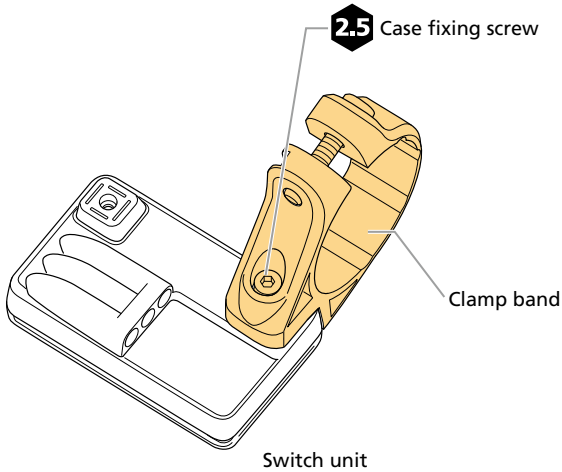

Switch unit integrated type cycle computer

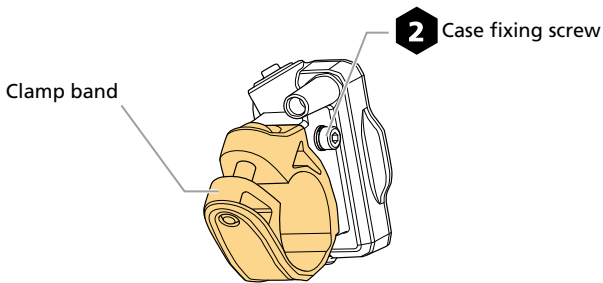
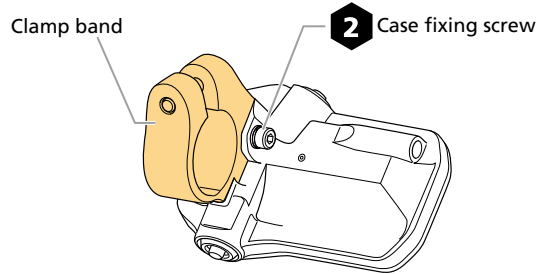

## 2. Install the new clamp band.

Clamp band type cycle computer

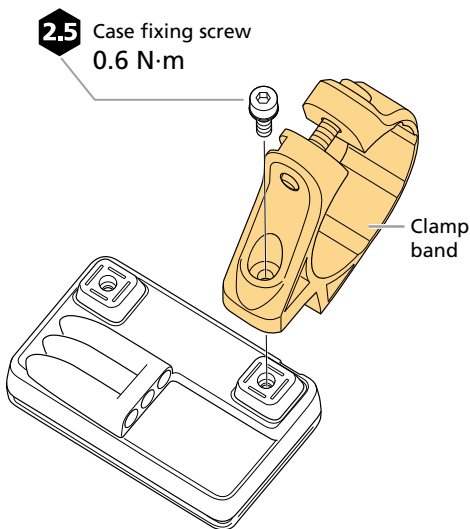

Switch unit integrated type cycle computer

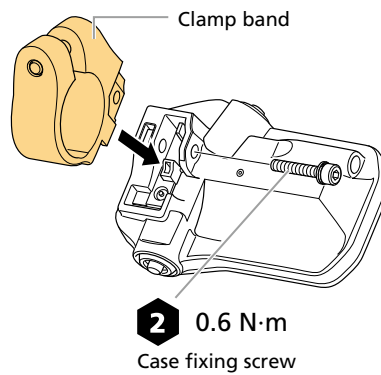

## Maintenance

### Replacing the clamp band

---

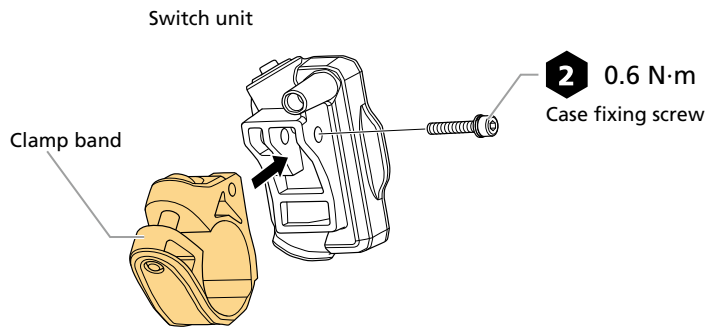

#### **NOTICE**

- Make sure to use the included screws. Other screws may damage the cycle computer or have insufficient holding force.

# Gear shifting adjustment ([Adjust])

## ⚠ CAUTION

- Refer to the dealer's manual for the rear derailleur/motor unit first to confirm whether adjustment is required before perform adjustment. Under normal conditions, performing unnecessary adjustment may worsen gear shifting performance. Improper adjustment may cause gear engagement skipping, resulting in an accidental fall.

## NOTICE

- Mount the bicycle to a maintenance stand or otherwise secure it in place so that the rear wheel can be spun freely.

## TECH TIPS

- The adjustment range of [Adjust] differs depending on the component and gear position, as shown below. This section uses screens from a rear derailleur model for explanation.

Component	Gear position	Adjustment range
Rear derailleur	12	37 steps (Initial position $0 \pm 18$ steps)
	11	33 steps (Initial position $0 \pm 16$ steps)
	10	31 steps (Initial position $0 \pm 15$ steps)
Internal geared hub	11, 8, 5	9 steps (Initial position $0 \pm 4$ steps)

- For a bicycle without a cycle computer, the gear shifting can be adjusted as indicated below:
  - Connect to E-TUBE PROJECT Professional or E-TUBE PROJECT Cyclist.  
Refer to the [user's manual for E-TUBE PROJECT Professional](#) or [user's manual for E-TUBE PROJECT Cyclist](#).
  - For a rear derailleur that supports switching to the adjustment mode, you can press and hold the function button to switch to the adjustment mode or operate the shift switch to perform gear shifting adjustment. Refer to the dealer's manual for the rear derailleur being used.
  - For a switch unit that supports adjustment mode switching, you can press and hold the A button to switch to the adjustment mode. For details on the operations after switching to the adjustment mode, refer to the dealer's manual for the rear derailleur being used.

## Notation method for operations

Subsequent operations using the main body button of the cycle computer and switch unit are indicated using the following notation. Refer to each user's manual for information on the main body button of the cycle computer and switches of the switch unit.

Notation	Operation
<↑>	Indicates an operation for pressing X on the assist switch or switch unit integrated type cycle computer.
<↓>	Indicates an operation for pressing Y on the assist switch or switch unit integrated type cycle computer.
<▲>	Indicates a shifting up operation of the shift switch.
<▼>	Indicates a shifting down operation of the shift switch.
[Adjust] (Example) Gear shifting adjustment	Items displayed on the cycle computer screen are enclosed in square brackets in this manual. When this notation is used in a procedure, it indicates an operation for selecting a display on the screen and pressing A on the assist switch to switch the screen or confirm the setting.
<A>	Indicates an operation for pressing A on the assist switch or switch unit integrated type cycle computer.

## Checking the setting value

First check whether the [Adjust] setting value is [0].

Refer to the user's manual for each cycle computer for information on the method for displaying the setting menu screen.

### 1. Setting menu ⇒ [Adjust] ⇒ check the current setting value

\* Switch unit integrated type: With [GEAR] displayed, press and hold <A> on the cycle computer until the display switches to [ADJUST].

- Value is [0]: Proceed to "[Adjusting when the setting value is \[0\].](#)"
- Value is not [0]: Proceed to "[Adjusting when the setting value is not \[0\].](#)"

Clamp band type  
Cycle computer example  
(SC-EN600)

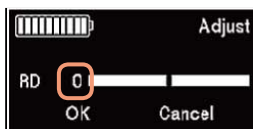

Switch unit integrated type  
cycle computer example  
(SC-EN500)

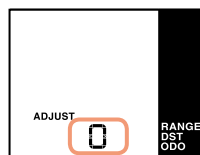
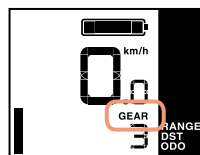

## Adjusting when the setting value is [0]

Adjust the setting value one step at a time with [0] as the reference value.

### 1. <▲><▼> (adjust the setting value by one step)

Gear shifting adjustment ([Adjust])

Clamp band type  
Cycle computer example  
(SC-EN600)

Switch unit integrated type  
cycle computer example  
(SC-EN500)

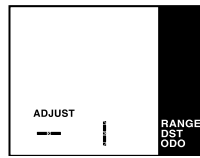

2. <↑><↓> (select [OK]) ⇒ <A>

\* Switch unit integrated type: <A>

The adjustment value is set and the screen returns to the basic screen.

Clamp band type  
Cycle computer  
example(SC-EN600)

Switch unit integrated  
type cycle computer  
example(SC-EN500)

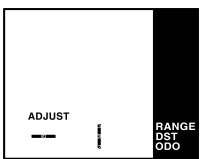
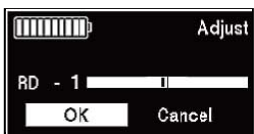

3. Try gear shifting operations.

Press <▲><▼> while turning the crank to perform gear shifting, and confirm that the adjustment has changed.

4. Proceed to adjust according to the symptom, as shown below.

Change the adjustment value according to the symptom, and repeat the following until the abnormal noise or unusual feel is resolved.

**If the symptom is improved, or there is no noticeable change**

- (1) Change the adjustment value by another step in the same direction (positive or negative) as the change that was just made.
- (2) Return to the basic screen, and once again shift gears to check the symptom.

Clamp band type Cycle  
computer example  
(SC-EN600)

Switch unit integrated type cycle computer  
example (SC-EN500)

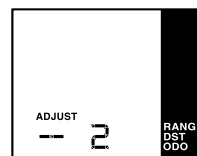
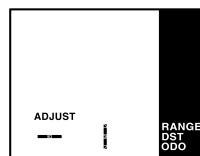
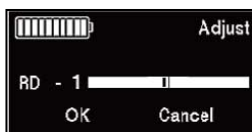

**If the symptom is worse**

- (1) Change the adjustment value two steps in the opposite direction (positive or negative) as the change that was just made.
- (2) Return to the basic screen, and once again shift gears to check the symptom.

Clamp band type Cycle computer example (SC-EN600)

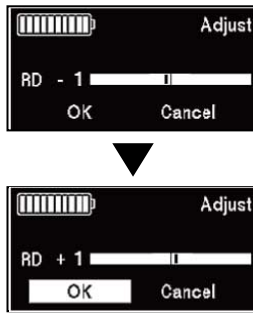

Switch unit integrated type cycle computer example (SC-EN500)



5. Finally, ride the bicycle and try shifting gears to check that the abnormal noise or unusual feel has been resolved.

## Adjusting when the setting value is not [0]

If the setting value is not [0], set the setting value to [0] prior to adjusting.

1. <▲><▼> (return the setting value to [0]) ⇒ <↑><↓> (select [OK]) ⇒ <A>

\* Switch unit integrated type: <▲><▼> (return the setting value to [0]) ⇒ <A>

Clamp band type Cycle computer example (SC-EN600)

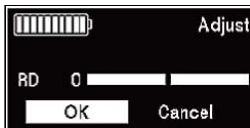

Switch unit integrated type cycle computer example (SC-EN500)

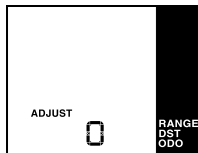

2. Try gear shifting operations.

Press <▲><▼> while turning the crank to perform gear shifting, and confirm that the adjustment has changed. Refer to step 4 in "Adjusting when the setting value is [0]" and adjust according to the symptom.

3. Finally, ride the bicycle and try shifting gears to check that the abnormal noise or unusual feel has been resolved.

## Time settings

The time is automatically corrected to the current time when you connect to E-TUBE PROJECT Professional. Some cycle computers may not have a function for displaying the time, but their system still has an internal time which is used for determining when to notify the user of maintenance alerts, for unit logs, etc.

# Troubleshooting

For details on error/warning codes displayed on the cycle computer, check the latest versions below:



<https://si.shimano.com/iER/STP0A>

The FAQ for SHIMANO E-BIKE SYSTEMS can also be accessed with the following:



<https://si.shimano.com/iFAQ/STP0A>

# SHIMANO

**SHIMANO NORTH AMERICA BICYCLE, INC.**  
One Holland, Irvine, California 92618, U.S.A. Phone: +1-949-951-5003

**SHIMANO EUROPE B.V.**  
High Tech Campus 92, 5656 AG Eindhoven, The Netherlands Phone: +31-402-612222  
Only EU General Contact : [contactshimano@shimano-eu.com](mailto:contactshimano@shimano-eu.com)

**SHIMANO INC.**  
3-77 Oimatsu-cho, Sakai-ku, Sakai City, Osaka 590-8577, Japan

Please note: specifications are subject to change for improvement without notice. (English)  
© Dec. 2024 by SHIMANO INC. ITP