

Dealer's Manual

ROAD	MTB	Trekking
City Touring/ Comfort Bike	URBAN SPORT	E-BIKE

Hub set (Disc brake)

HB-RS770
HB-RS470
HB-R7070

FH-RS770
FH-RS470
FH-R7070

CONTENTS

- IMPORTANT NOTICE..... 3**
- TO ENSURE SAFETY..... 4**
- LIST OF TOOLS TO BE USED..... 7**
- INSTALLATION 9**
 - Spoke lacing9
 - Installation of the disc brake rotor9
- MAINTENANCE 11**
 - Front hub11
 - Freehub..... 14

IMPORTANT NOTICE

- **This dealer's manual is intended primarily for use by professional bicycle mechanics.**

Users who are not professionally trained for bicycle assembly should not attempt to install the components themselves using the dealer's manuals. If any part of the information on the manual is unclear to you, do not proceed with the installation. Instead, contact your place of purchase or a local bicycle dealer for their assistance.

- Make sure to read all instruction manuals included with the product.
- Do not disassemble or modify the product other than as stated in the information contained in this dealer's manual.
- All dealer's manuals and instruction manuals can be viewed on-line on our website (<http://si.shimano.com>).
- Customers who do not use the internet may have to contact their place of purchase to receive a hard copy of the user's manual. You may print out a user's manual to hand to your customer or you may need to ask the nearest SHIMANO sales office for a hard copy of the user's manual.
- Please observe the appropriate rules and regulations of the country, state or region in which you conduct your business as a dealer.

For safety, be sure to read this dealer's manual thoroughly before use, and follow it for correct use.

The following instructions must be observed at all times in order to prevent personal injury and physical damage to equipment and surroundings. The instructions are classified according to the degree of danger or damage which may occur if the product is used incorrectly.



Failure to follow the instructions will result in death or serious injury.



Failure to follow the instructions could result in death or serious injury.



Failure to follow the instructions could cause personal injury or physical damage to equipment and surroundings.

TO ENSURE SAFETY

WARNING

- **Be sure to follow the instructions provided in the manuals when installing the product.**

It is recommended to use genuine SHIMANO parts only. If parts such as bolts and nuts become loose or damaged, the bicycle may suddenly fall over, which may cause serious injury.

In addition, if adjustments are not carried out correctly, problems may occur, and the bicycle may suddenly fall over, which may cause serious injury.

-  Be sure to wear safety glasses or goggles to protect your eyes while performing maintenance tasks such as replacing parts.
- After reading the dealer's manual thoroughly, keep it in a safe place for later reference.

Be sure to also inform users of the following:

- **Check that the wheels are fastened securely before riding the bicycle. If the wheels are loose in any way, they may come off the bicycle and cause serious injury.**

- If the axle release lever is on the same side as the disc brake rotor, there is a possibility they may interfere.

Make sure that, even if the axle release lever is tightened as much as possible by hand, the axle release lever does not interfere with the disc brake rotor. If the lever interferes with the disc brake rotor, stop using the wheel and consult a dealer or an agency.

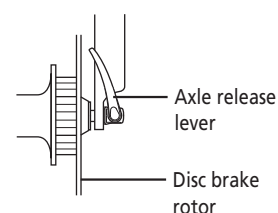

- If the axle release lever is not used correctly, the wheel may come off the bicycle and serious injury could result.
- For details on the E-THRU Axle, refer to the E-THRU Axle user's manual.
- The disc brake calipers and disc brake rotor will become hot when the brakes are operated, so do not touch them while riding or immediately after dismounting from the bicycle. Otherwise you may get burned. Check that the brake components have cooled down sufficiently before attempting to adjust the brakes.
- This hub can be used in combination with the special front fork/frame and the fixed axle only. If it is used in combination with any other front fork/frame or fixed axle, it may cause the wheel to become detached from the bicycle while you are riding and result in serious bodily injury.

For Installation to the Bicycle, and Maintenance:

- The securing method and tightening torque for the front wheel both vary depending on the type of front suspension fork being used. When installing the front wheel to the front suspension fork, always be sure to follow the directions given in the Service Instructions for the front suspension fork. If the instructions are not followed, the front wheel may fall out of the front suspension fork and serious injury may occur. When the front wheel is tightened onto the front suspension fork in accordance with the instruction manual, the front wheel's rotation may become stiff; however, the instructions must always be followed.
- It is strongly recommended that only the hub axle that is shipped with the SHIMANO hub is used. If a different hub axle is used to secure the hub, it may not have sufficient strength to secure the freehub, or the axle may break because of insufficient strength, and this may cause the wheel to fall off, and serious injury may occur.
- Be sure to also carefully read the Service Instructions for the disc brakes.

**For Installation to the Bicycle, and Maintenance:**

- When using the SHIMANO original tool (TL-LR15) to remove and install the disc brake rotor fixing ring, be careful not to touch the outside of the disc brake rotor with your hands. Wear gloves to protect your hands from getting cut.

■ Burn-in period

- Disc brakes have a burn-in period, and the braking force will gradually increase as the burn-in period progresses. Make sure that you are aware of any such increases in braking force when using the brakes during the burn-in period. The same thing will happen when the brake pads or disc brake rotor are replaced.

NOTICE**Be sure to also inform users of the following:**

- This product is not warranted against damage resulting from improper use, such as jumping while riding or if the bicycle falls over, except if such malfunctions are caused by manufacturing methods.
- Products are not guaranteed against natural wear and deterioration from normal use and aging.
- For maximum performance we highly recommend SHIMANO lubricants and maintenance products.

For Installation to the Bicycle, and Maintenance:







- If the wheel becomes stiff and difficult to turn, lubricate it with grease.
- Do not lubricate the internal parts of the hub. Otherwise, grease will flow out.
- When replacing the E-THRU Axle, make sure that the replacement E-THRU Axle is of the same model as the current E-THRU Axle attached to the frame.
A different model may not be mounted properly onto the frame due to differences in axle length, screw size, housing diameter, etc.
- Use the TL-FH12 when attaching the front hub to the wheel truing tool.

The actual product may differ from the illustration because this manual is intended mainly to explain the procedures for using the product.

LIST OF TOOLS TO BE USED

LIST OF TOOLS TO BE USED

The following tools are needed for installation, adjustment, and maintenance purposes.

Tool		Tool		Tool	
	15 mm hub spanner		22 mm hub spanner		TL-FH15
	17 mm hub spanner		Adjustable wrench		
	20 mm hub spanner		TL-LR15		

INSTALLATION

INSTALLATION

■ Spoke lacing

Check that the spokes have been laced as shown in the illustration.
A radial lacing cannot be used.

Rotating direction of wheel

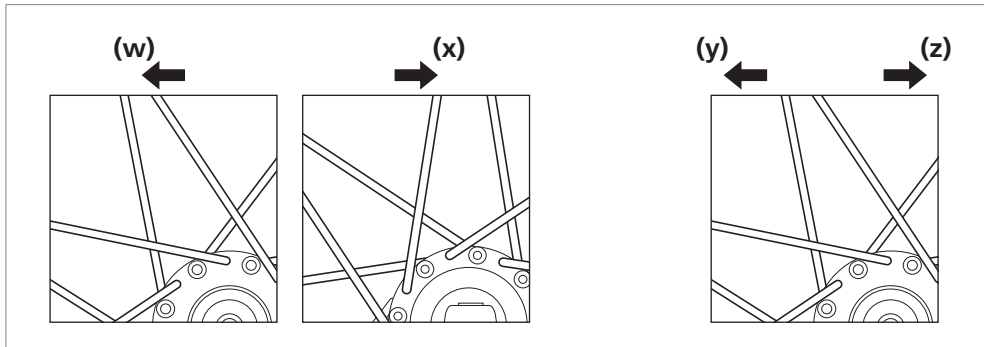

(w) For front: Left (disc brake rotor) side

(x) For front: Right side

(y) For rear: Left (disc brake rotor) side

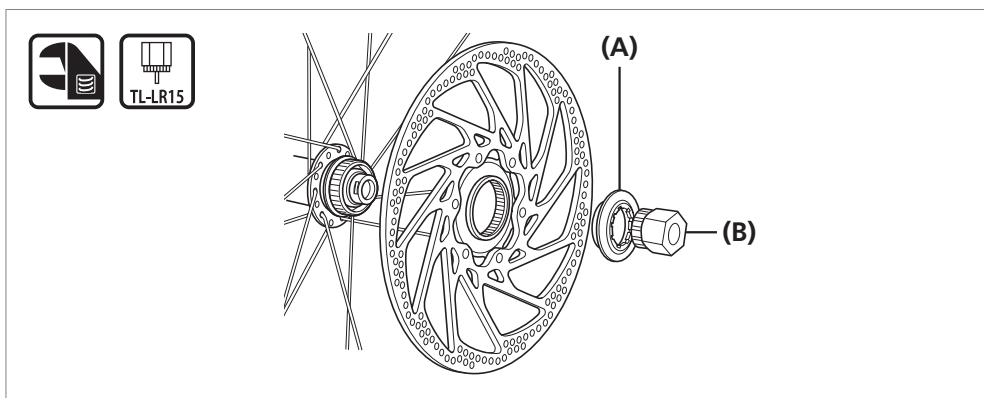

(z) For rear: Right (sprocket) side

■ Installation of the disc brake rotor



(A) Disc brake rotor fixing lock ring

(B) TL-LR15

Tightening torque	
 	<p>40 N·m</p>

MAINTENANCE

MAINTENANCE

The hub can be disassembled as shown in the illustration. Apply grease to the various parts at periodic intervals.

■ Front hub

HB-RS770

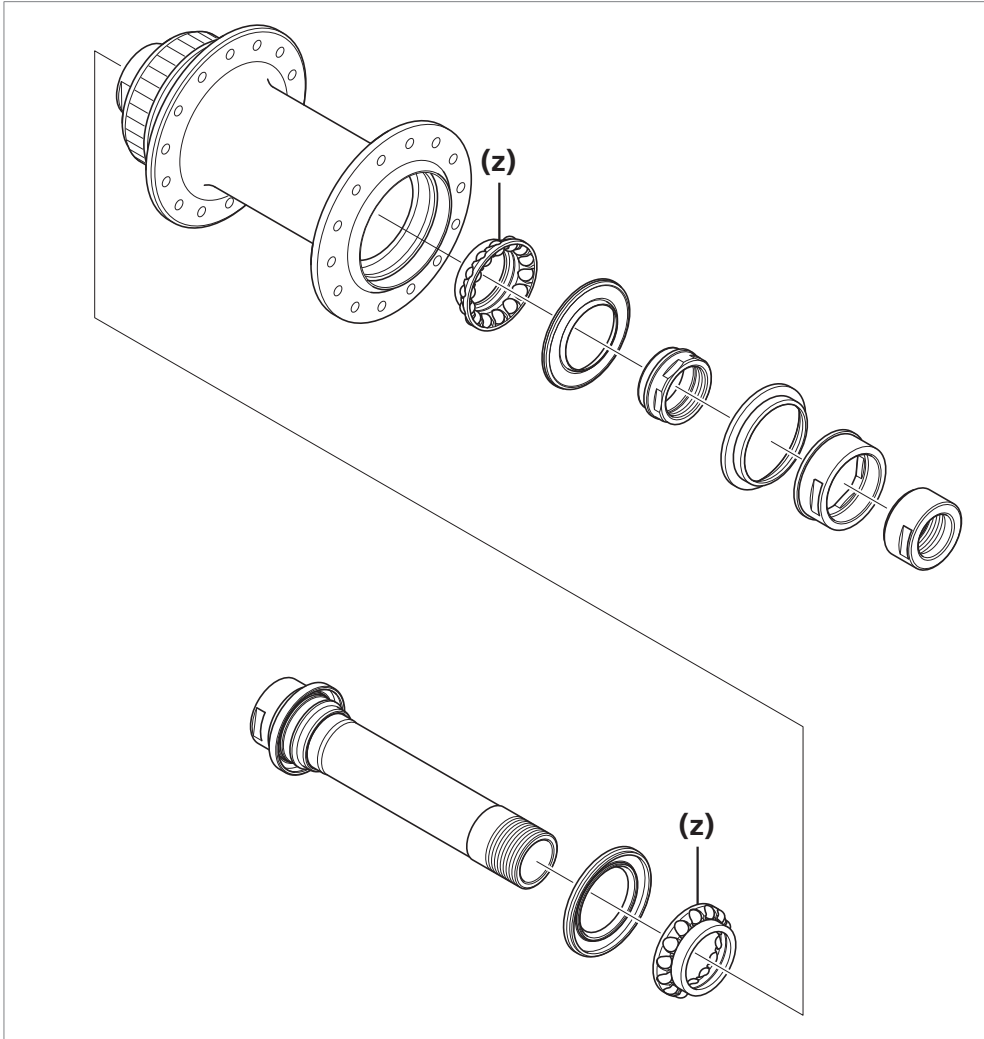

(z) Apply grease: Premium grease (Y-04110000)

Assembly

Install the hub axle, and then use hub spanners to tighten the lock nut so as to double-lock the mechanism.

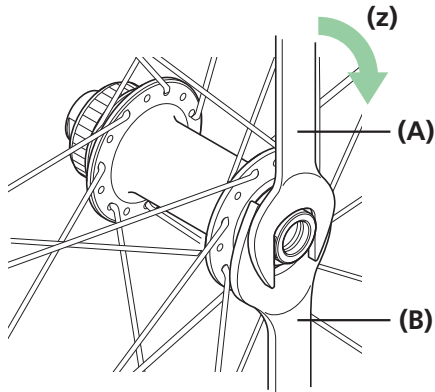

(z) Tighten

(A) 17 mm hub spanner

(B) 22 mm hub spanner

Tightening torque



18 - 20 N·m

HB-R7070/HB-RS470

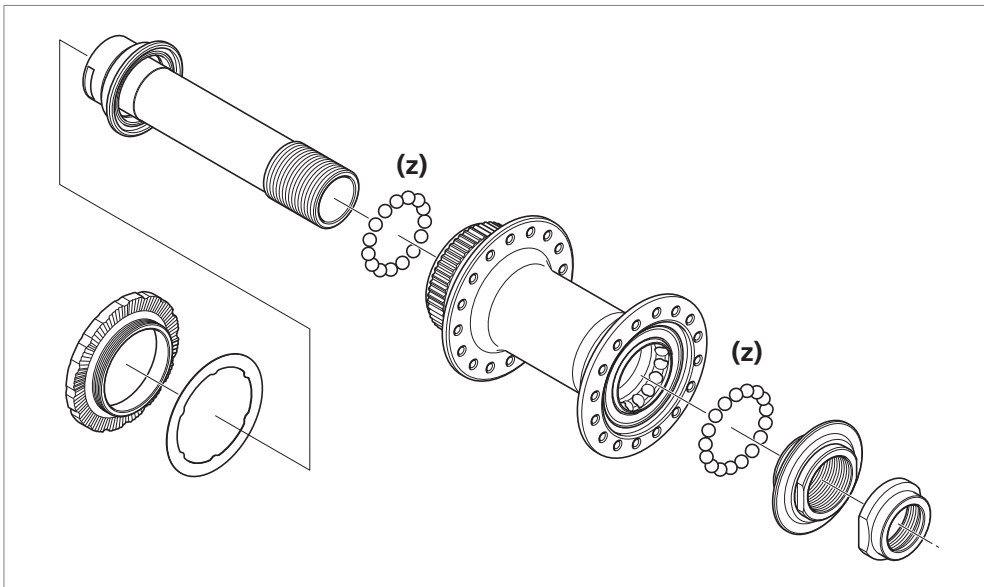

(z) Apply grease: Premium grease (Y-04110000)

Assembly

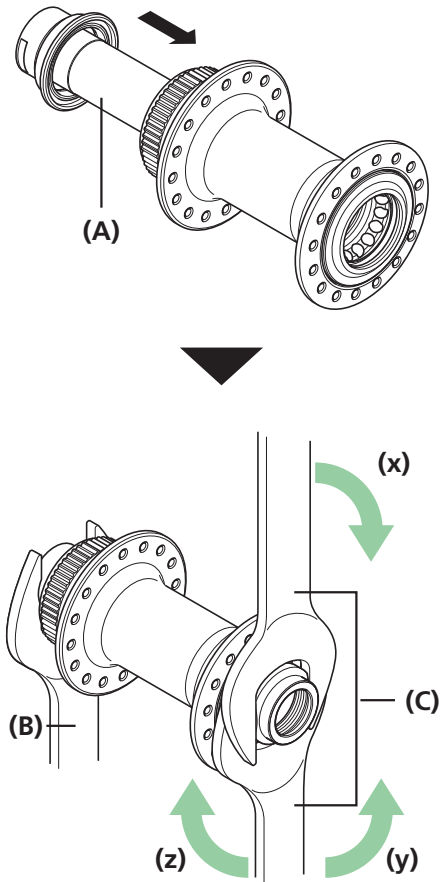

Install the hub axle (A) into hub as in the illustration.

While holding the LH cone nut with 15 mm hub spanner (B), use the 20 mm hub spanner (C) to tighten (y) or loosen (z) the RH side cone for rotation feeling adjustment. Using another 20 mm hub spanner (C), tighten (x) the RH lock nut so as to double-lock the mechanism.

- (x) Tighten
- (y) Loosen
- (z) Tighten

- (A) Hub axle
- (B) 15 mm hub spanner
- (C) 20 mm hub spanner

Tightening torque (x)	
	21 - 26 N·m

Freehub

NOTICE

- When removing and installing the seal, do so very carefully so that the seal does not become bent. When reinstalling the seal, make sure that it is facing the right way, and insert it as far as it will go.
- Do not disassemble the dust covers which are crimped onto the axle, the right nut and the cone.
- Do not attempt to disassemble the freewheel body, because it may result in a malfunction.

FH-RS770

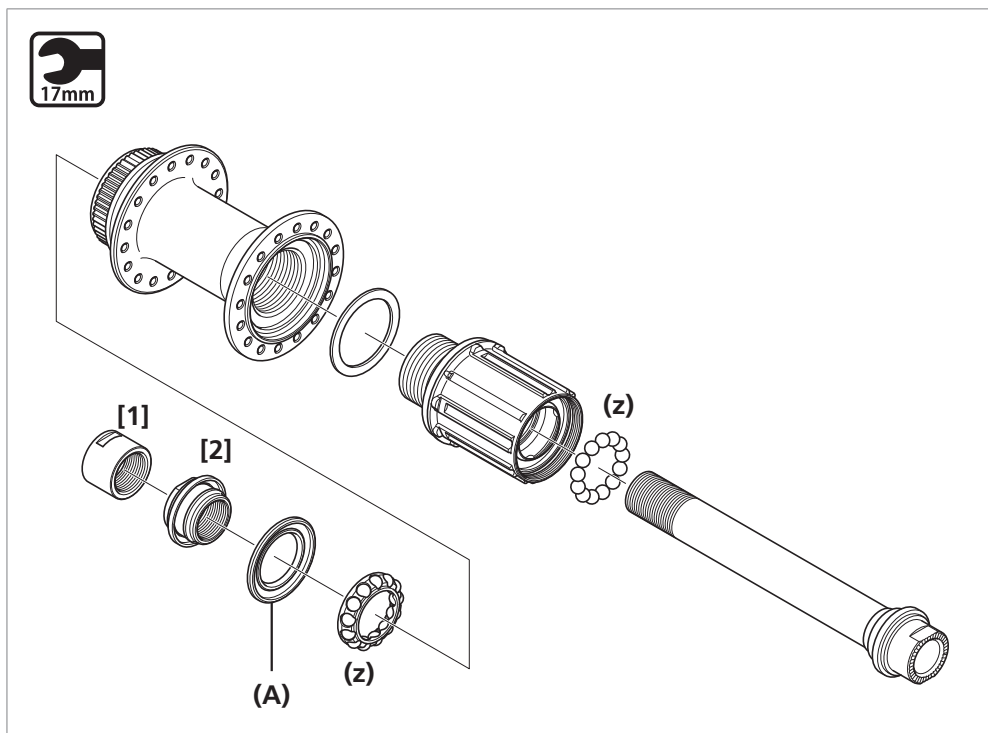

(z) Apply grease: Premium grease (Y-04110000)

(A) Seal (Lip is on the outside)

NOTICE

The correct position for the dust cover is where it is hidden in the freewheel body, as shown in illustration [1]. If the dust cover is in the position shown in illustration [2], repeat the assembly process from the beginning.

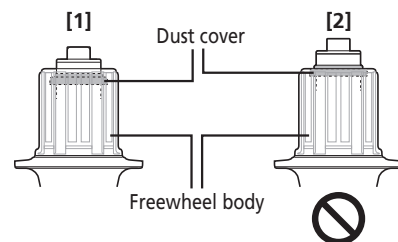

	Part name	Thread type	Tool	Tightening torque
[1]	Left hand lock nut (M15.5)	Clockwise thread	17 mm hub spanner	17 - 22 N·m
[2]	Left hand cone (M15.5)	Clockwise thread	17 mm hub spanner	-

FH-R7070/FH-RS470

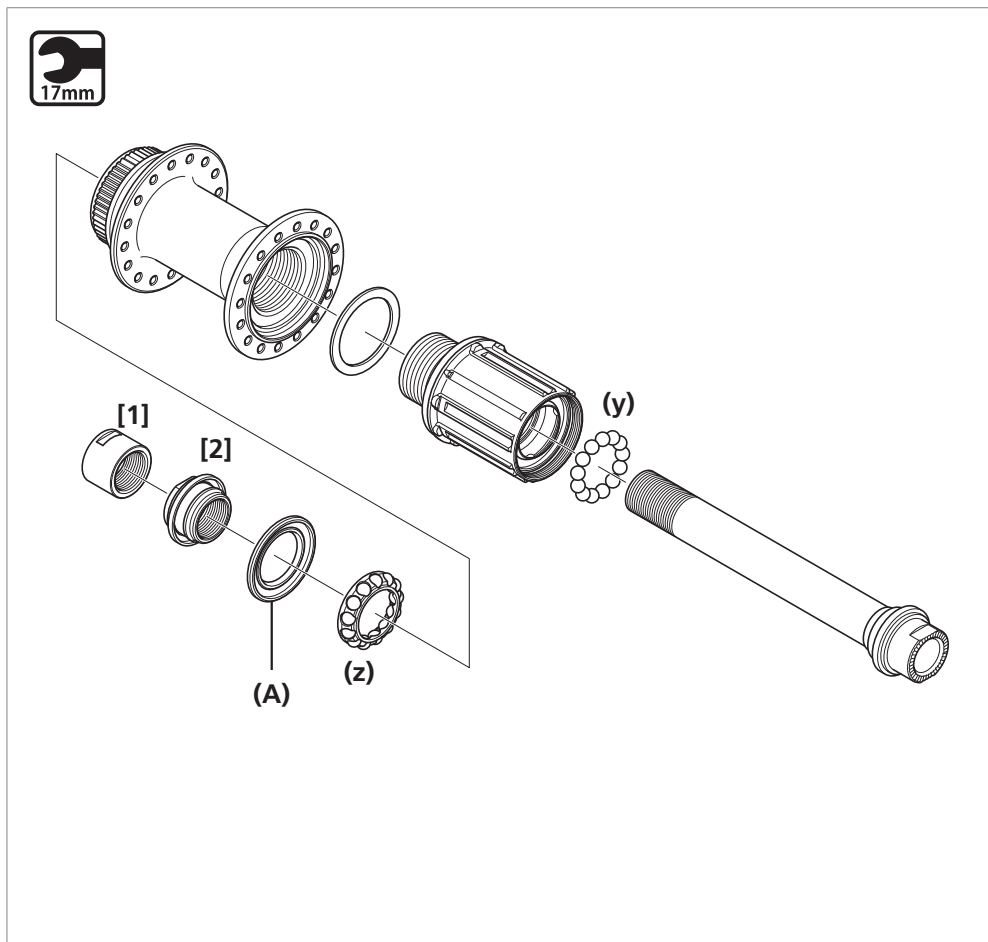

(y) Apply grease: Premium grease (Y-04110000)
 Number of balls: 16
 Ball size: 5/32"

(z) Apply grease: Premium grease (Y-04110000)
 Number of balls: 15
 Ball size: 5/32"

(A) Seal (Lip is on the outside)

NOTICE

The correct position for the dust cover is where it is hidden in the freewheel body, as shown in illustration [1]. If the dust cover is in the position shown in illustration [2], repeat the assembly process from the beginning.

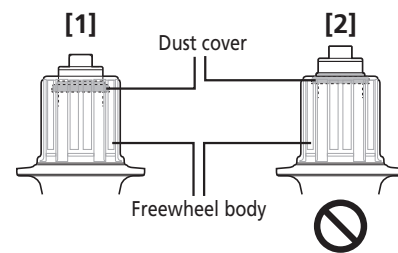

	Part name	Thread type	Tool	Tightening torque
[1]	Left hand lock nut (M15)	Clockwise thread	17 mm hub spanner	15 - 20 N·m
[2]	Left hand cone (M15)	Clockwise thread	17 mm hub spanner	-

Replacement of the freewheel body

Pulling out the hub axle (FH-RS770 / FH-R7070 / FH-RS470)

1

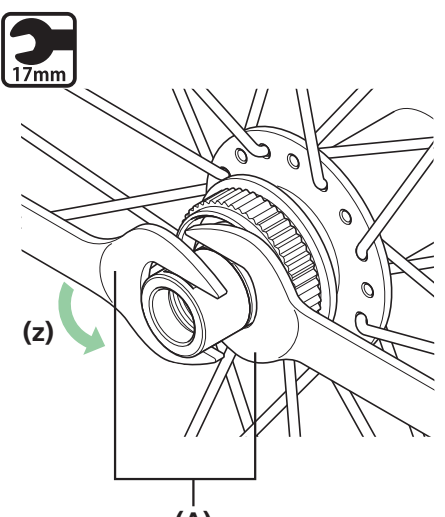

Use the spanner to loosen the lock nut on the double-lock section.

(z) Disassembly

(A) 17 mm hub spanner

FH-RS770

Tightening torque	
	17 - 22 N·m

FH-R7070/FH-RS470

Tightening torque	
	15 - 20 N·m

2

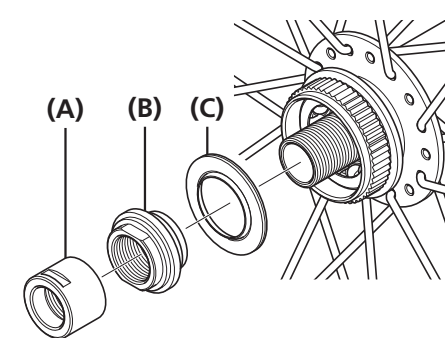

Remove as shown in the illustration.

- (A)** Lock nut
- (B)** Cone with dust cover
(Cannot be disassembled)
- (C)** Seal ring

3

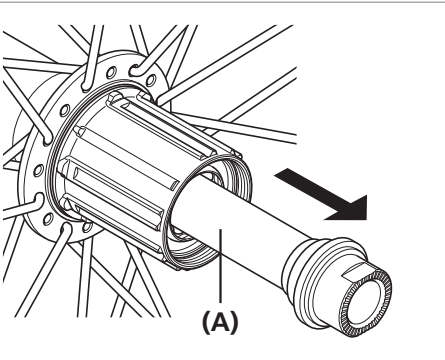

Pull out the hub axle from the freewheel body.

(A) Hub axle

Replacement of the freewheel body

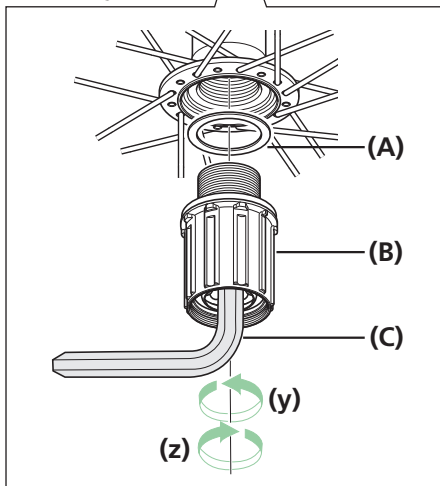
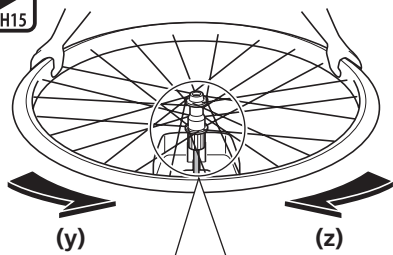

Replace the freewheel body as shown in the illustration.
After removing the hub axle, insert TL-FH15 into the freewheel unit, secure the tool so that it does not rotate and then rotate the wheel.

- (y) Disassembly
- (z) Assembly

- (A) Freewheel body washer
- (B) Freewheel body
- (C) TL-FH15

Tightening torque



150 N·m

NOTICE

- Do not attempt to disassemble the freewheel body, because it may result in a malfunction.
- The correct position for the dust cover is when it is hidden in the freewheel body, as shown in illustration [1]. If the dust cover is in the position shown in illustration [2], repeat the assembly process from the beginning.

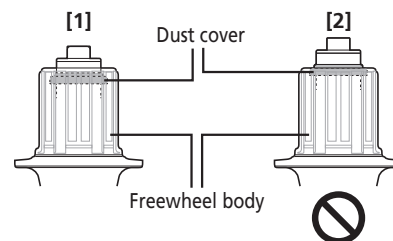

SHIMANO

SHIMANO NORTH AMERICA BICYCLE, INC.

One Holland, Irvine, California 92618, U.S.A. Phone: +1-949-951-5003

SHIMANO EUROPE B.V.

High Tech Campus 92, 5656 AG Eindhoven, The Netherlands Phone: +31-402-612222

SHIMANO INC.

3-77 Oimatsu-cho, Sakai-ku, Sakai-shi, Osaka 590-8577, Japan

Please note: specifications are subject to change for improvement without notice. (English)

© Dec. 2018 by SHIMANO INC. ITP