

Dealer's Manual

ROAD	MTB	Trekking
City Touring/ Comfort Bike	URBAN SPORT	E-BIKE

Front Derailleur (Di2)

SHIMANO 105

FD-R7150

Contents

IMPORTANT NOTICE	3
TO ENSURE SAFETY	4
List of tools to be used	7
Installation/removal	8
Temporarily installing the front derailleur.....	8
Securing the front derailleur.....	13
Adjustment	17
Adjusting the front derailleur	17
Maintenance	21
Replacing the skid plate	21



IMPORTANT NOTICE

- This dealer's manual is intended primarily for use by professional bicycle mechanics. Users who are not professionally trained for bicycle assembly should not attempt to install the components themselves using the dealer's manuals. If any part of the information on the manual is unclear to you, do not proceed with the installation. Instead, contact your place of purchase or a distributor for assistance.
- Make sure to read all manuals included with each product.
- Do not disassemble or modify the product other than as stated in the information contained in this dealer's manual.
- All manuals and technical documents are accessible online at <https://si.shimano.com> .
- For consumers who do not have easy access to the internet, please contact a SHIMANO distributor or any of the SHIMANO offices to obtain a hardcopy of the user's manual.
- Please observe the appropriate rules and regulations of the country, state or region in which you conduct your business as a dealer.

For safety, be sure to read this dealer's manual thoroughly before use, and follow it for correct use.

The following instructions must be observed at all times in order to prevent personal injury and physical damage to equipment and surroundings.

The instructions are classified according to the degree of danger or damage which may occur if the product is used incorrectly.

 DANGER	Failure to follow the instructions will result in death or serious injury.
 WARNING	Failure to follow the instructions could result in death or serious injury.
 CAUTION	Failure to follow the instructions could cause personal injury or physical damage to equipment and surroundings.

TO ENSURE SAFETY

WARNING

- Be sure to follow the instructions provided in the manuals when installing the product.
Only use SHIMANO genuine parts. If a component or replacement part is incorrectly assembled or adjusted, it can lead to component failure and cause the rider to lose control and crash.
-  Wear approved eye protection while performing maintenance tasks such as replacing components.

Be sure to also inform users of the following:

- Be careful not to let the hemming of your clothes get caught in the chain while riding. Otherwise, you may fall off the bicycle.

For installation to the bicycle and maintenance

- When operating the shift switch, be careful not to allow your fingers to be caught in the derailleur. The motor in the derailleur is powerful enough to be operated without stopping until the shifting position is reached, and may cause serious injury if your fingers interfere with the shifting motion.

NOTICE

Be sure to also inform users of the following:

- Be sure to rotate the crank arm when carrying out any operations which are related to gear shifting.
- The connectors are small and waterproof, so do not connect and disconnect electric wires except when necessary. Doing so may impair the waterproofing.
- Be careful not to get water into the E-TUBE ports.
- The components are designed to be fully waterproofed to withstand wet weather riding conditions; however, do not deliberately place them into water.
- Do not clean the bicycle in a high-pressure wash. If water gets into any of the components, operating problems or rusting may result.
- Be sure to keep rotating the crank arm during gear shifting operations.
- Handle the components carefully, and avoid subjecting them to strong shock.
- Do not use the thinners or harsh solvents to clean the products. Such solvents may damage the surface.
- If gear shifting operation does not feel smooth, consult the place of purchase for assistance.
- Keep away from magnetic objects. If this is not observed, problems with operation may occur.
When installing a product that uses a magnet, make sure the magnet is set in the specified location before installing the product.
- Contact the place of purchase for updates of the component software. The most up-to-date information is available on the SHIMANO website.
- Products are not guaranteed against natural wear and deterioration from normal use and aging.
- For maximum performance we highly recommend SHIMANO lubricants and maintenance products.

For installation to the bicycle and maintenance

- Be sure to attach dummy plugs to any unused E-TUBE ports.
- Be sure to use the SHIMANO original tool TL-EW300 to remove and install the electric wires.
- The clamp band, clamp screw and clamp nut are not compatible with other products. Be sure to always use the clamp band, clamp screw or clamp nut which is specific to each product.

■ Electric wires/electric wire covers

- Secure the electric wires with a zip tie so that they do not interfere with the gears or tires, etc.
- The strength of the adhesive is fairly weak to prevent the paint on the frame from being peeled off when removing the electric wire cover, such as when replacing the electric wires. If the electric wire cover is peeled off, replace it with a new one. When removing the electric wire cover, do not peel it off too vigorously. If so, the paint on the frame will peel off, too.
- Do not remove the wire holders which are attached to the internal type electric wires (EW-SD300-I). The wire

TO ENSURE SAFETY





holders prevent the electric wires from moving inside the frame.

- When installing to the bicycle, do not forcibly bend the electric wire plug. It may result in a poor connection.

The actual product may differ from the illustration because this manual is intended mainly to explain the procedures for using the product.

List of tools to be used

The following tools are needed for installation, adjustment, and maintenance purposes.

Tool	
	TL-EW300
	2 mm hexagon wrench
	5 mm hexagon wrench
	Snap ring removal tool

Installation/removal

Temporarily installing the front derailleur

The recommended installation order for the front derailleur varies depending on whether the wiring is inside or outside the frame.

- If the wiring is inside the frame, temporarily install the front derailleur as described here, check all connections (including with other components), then proceed to " Securing the front derailleur ".
- If the wiring is outside the frame, refer to the information here as well as the information in " Securing the front derailleur ", then complete installing the front derailleur.

When there is a mounting boss on the seat tube

Be sure to install the support plate to prevent the frame from being damaged by pressure from the support screw.

1. Check the installation location.

Check where the support screw makes contact with the seat tube when adjusting the front derailleur support screw.

Installation/removal

Temporarily installing the front derailleur

2. Temporarily install the front derailleur.

- (1) Peel the film on the back, then attach the support plate to the seat tube.
 - * Avoid positioning the adhesive on the support plate between the contact point of the support screw and the frame.
- (2) Temporarily install the front derailleur.

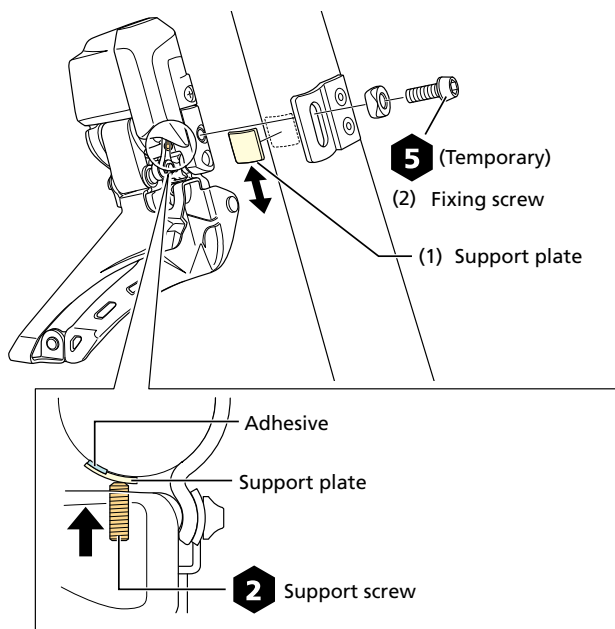

When there is no mounting boss on the seat tube

When there is no mounting boss on the seat tube, use a band adapter (SM-AD91).

1. Install the band adapter to the front derailleur.

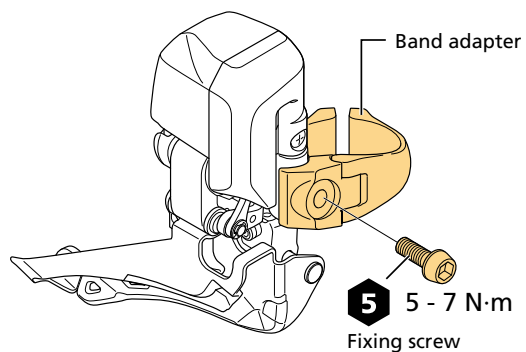

2. Tighten the support screw until it touches the band adapter.

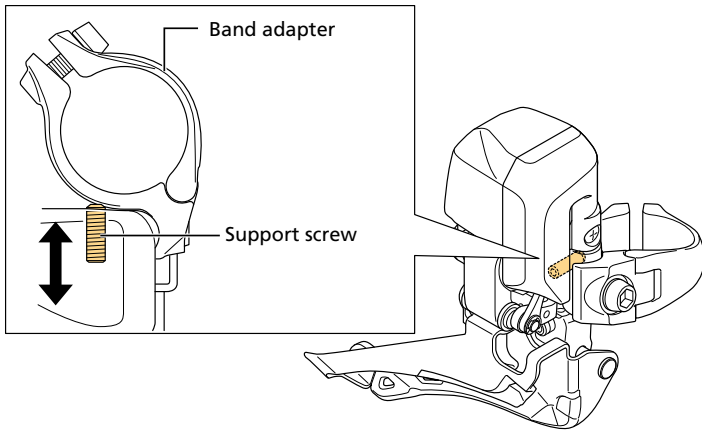

3. Temporarily install the front derailleur to the seat tube.

- (1) Remove the clamp screw, and expand the clamp band of the band adapter.
 - (2) Set the clamp band to the frame, and reinstall the clamp screw.
- * Use a seat tube adapter (for $\text{Ø}28.6$) according to the size of the seat tube.

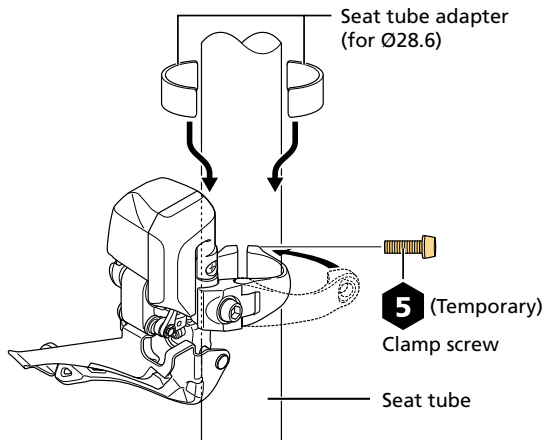

Connecting the electric wire

1. Connect the electric wire.

- (1) Install the electric wire to the plug cover.
- (2) Connect the electric wire with the plug cover to the E-TUBE port of the front derailleur.
* Be sure to push it in firmly until you feel a click.

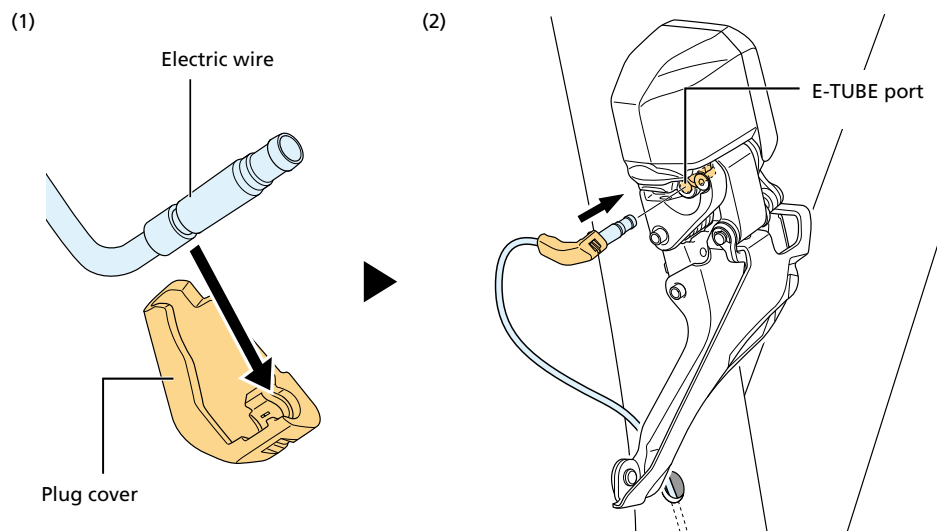

TECH TIPS

- When removing the electric wire of the front derailleur, insert the SHIMANO original tool into the groove of the plug cover.

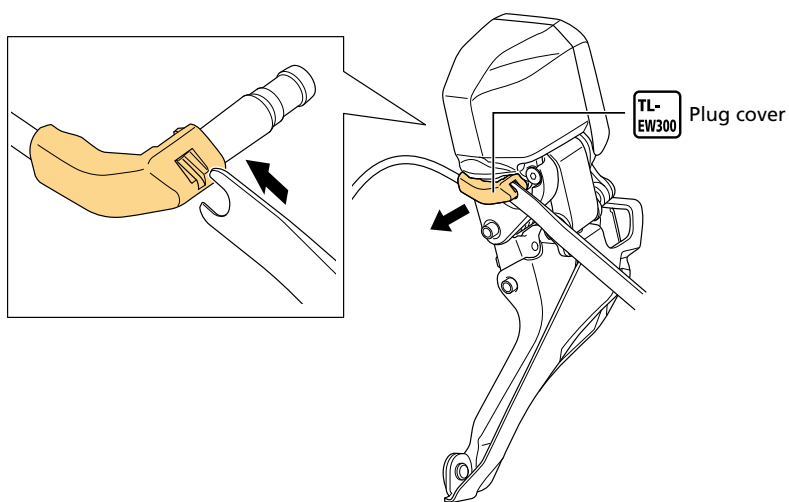

2. When checking of the connections is complete, temporarily remove the battery.

Refer to the battery dealer's manual .

⚠ WARNING

- Make sure to remove the battery when performing a procedure at a position near the front derailleur, such as installation and removal of the crankset and front derailleur, chain installation, and length adjustment. If the front derailleur is accidentally triggered while performing a maintenance procedure, your fingers could get caught in the front derailleur and be injured.

Securing the front derailleur

Preparations

1. Install the bottom bracket and crankset to the frame.

- Refer to the dealer's manual for the bottom bracket and crankset .
- If the front derailleur interferes with the installation of the crankset, temporarily remove it to aid the installation process.

Securing the front derailleur

Before starting the work, check that the procedures in “ Temporarily installing the front derailleur ” and “Checking connections” have been completed.

For details on “Checking connections”, refer to the separate booklet, “ ROAD Di2 Dealer's Manual General Guide .”

1. Adjust the installation height.

Adjust so that there is a gap of 1 - 3 mm between the outer plate and the tip of the teeth of the largest chainring.

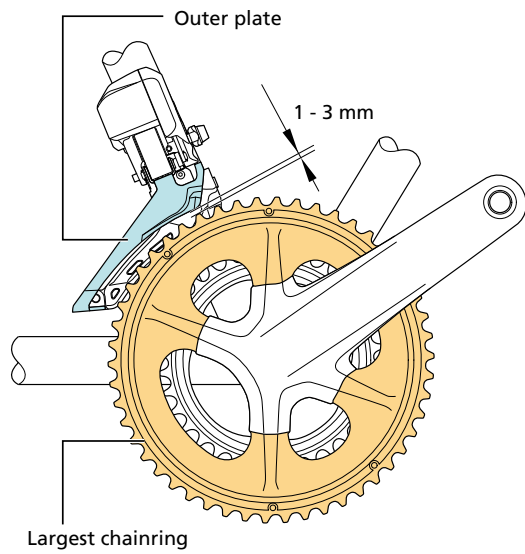

2. Adjust the installation angle and secure the front derailleur.

- (1) Perform adjustment so that the flat surface of the outer plate is in a position directly above the largest chainring and that the rear edge of the outer plate is inwards by 0.5 - 1 mm compared to the front edge.
- (2) Secure the front derailleur with a fixing screw or clamp screw.

With mounting boss (direct mount)

Without mounting boss (use band adapter)

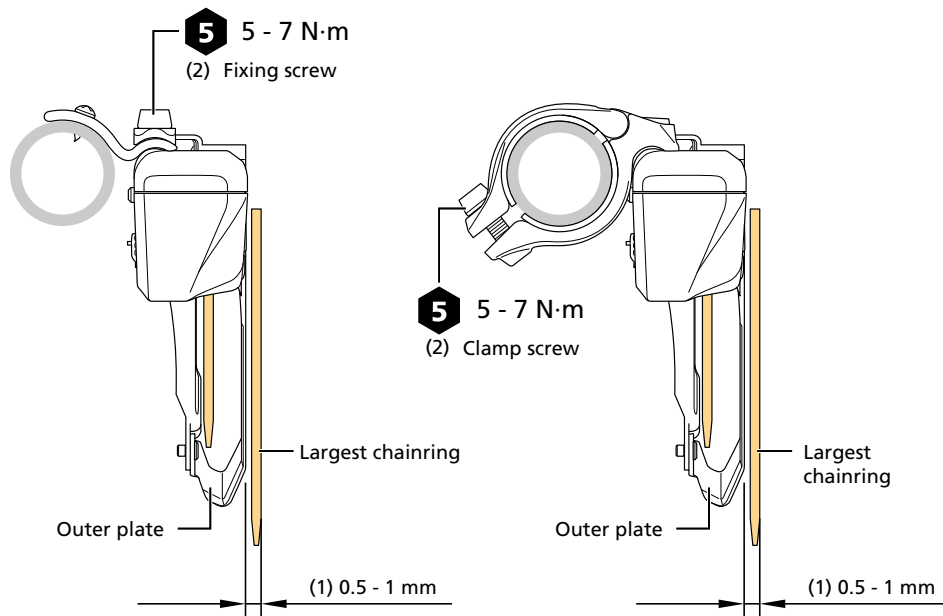

NOTICE

- When installing the front derailleur onto a carbon frame, confirm the recommended tightening torque with the carbon frame manufacturer. This will prevent damage to the frame due to over-torquing or inadequate securing of the components.

3. Readjust the position of the outer plate.

Adjust the support screw so that the flat surface of the outer plate is aligned with the surface of the largest chainring. Make sure that the support screw is in contact with the support plate or the band adapter.

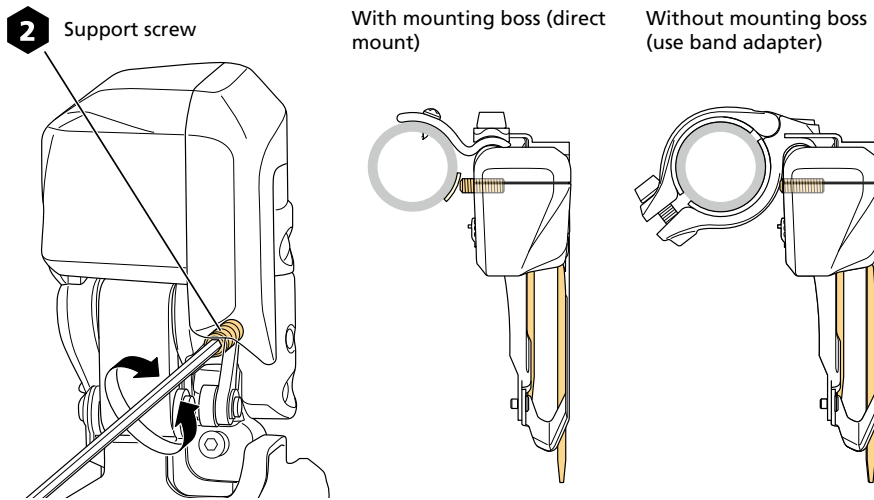

TECH TIPS

- Check the adjustment position by pressing a hexagon wrench or other tool to the flat portion of the largest chainring.

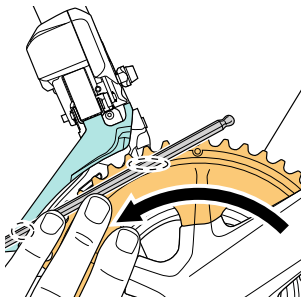

Adjustment

Adjusting the front derailleur

Adjusting the high limit

1. Shift the chain to the largest chainring and the largest sprocket.

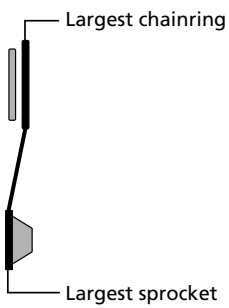

Adjustment

Adjusting the front derailleur

2. Adjust the gap between the chain and inner plate.

Adjust the clearance to 0 - 0.5 mm.

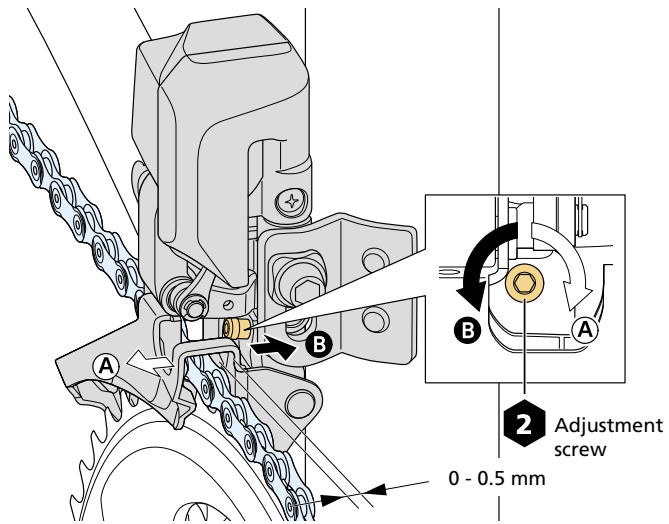

Adjusting the low limit

1. Shift the chain to the smallest chainring and the largest sprocket.

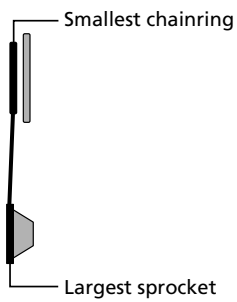

Adjustment

Adjusting the front derailleur

2. Switch the gear shifting system to adjustment mode.

Press the function button until the rear derailleur LED lights up yellow.

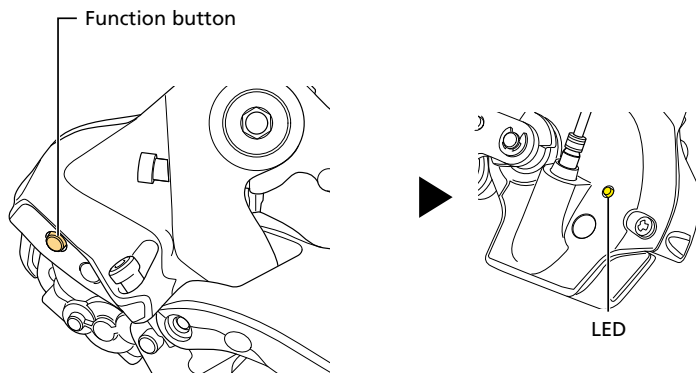

NOTICE

- If you keep pressing the function button after the rear derailleur LED lights up yellow, switch pairing mode will begin. Refer to the user's manual for the rear derailleur (Di2) for details. If you accidentally started switch pairing mode, press the function button again to switch back to normal mode and start over.

Adjustment

Adjusting the front derailleur

3. Adjust the gap between the chain and inner plate.

Adjust the clearance to 0 - 0.5 mm.

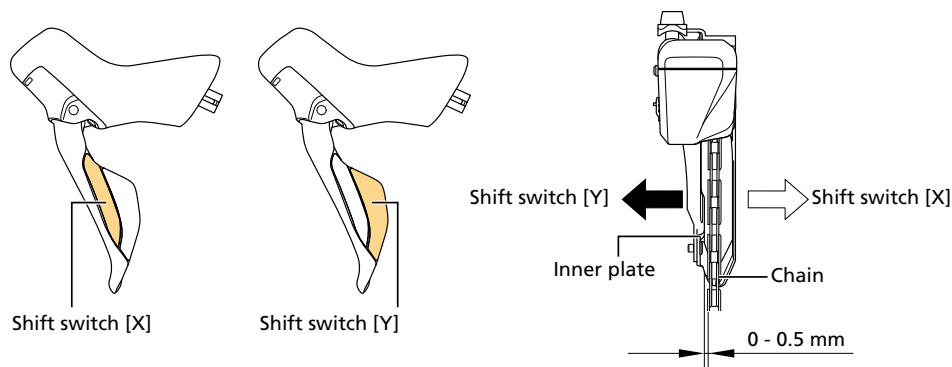

TECH TIPS

- The derailleur can move 18 steps inward and 18 steps outward from the initial position, for a total of 37 positions.
- In adjustment mode, the chain guide will overrun slightly then move back in an exaggerated manner so that you can check the adjustment direction. When checking the positions of the chain guide and the chain, perform the check when the front derailleur has come to a stop.

4. Switch the gear shifting system back to normal mode.

Press the rear derailleur function button and check that the LED is turned off.

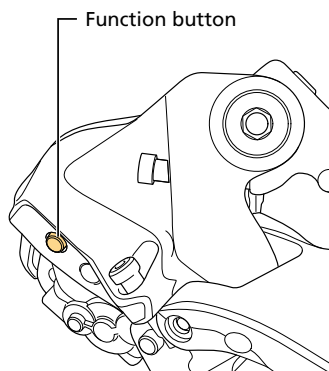

5. Shift the front derailleur and the rear derailleur to all gears to make sure that the chain does not contact the inner or outer plates.

If fine adjustment is needed, switch back to adjustment mode and readjust the front derailleur.

Maintenance

Replacing the skid plate



Removing the skid plate

1. Shift the chain to the largest chainring.

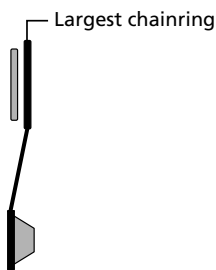

2. Remove the snap ring.

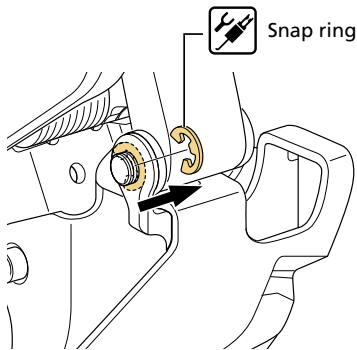

CAUTION

- When you remove the snap ring, it may pop out; wear protective glasses while removing it. Check that there is no one or no object around you before starting the work.

TECH TIPS

- If the snap ring is difficult to remove, use a commercially available special tool.

Maintenance

Replacing the skid plate

3. Remove the rivet A.

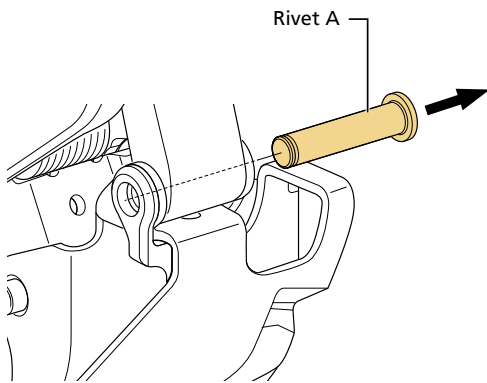

Maintenance

Replacing the skid plate

4. Remove the skid plate.

Push in the chain guide hooking tab from both sides, and pull off the skid plate.

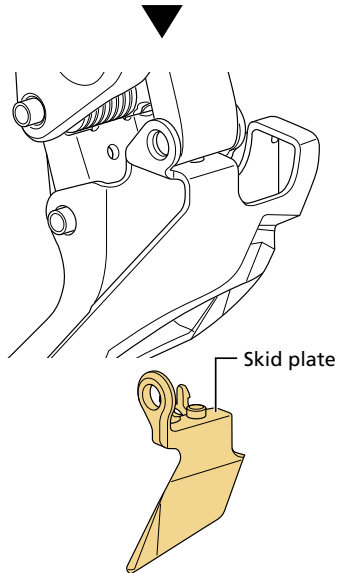
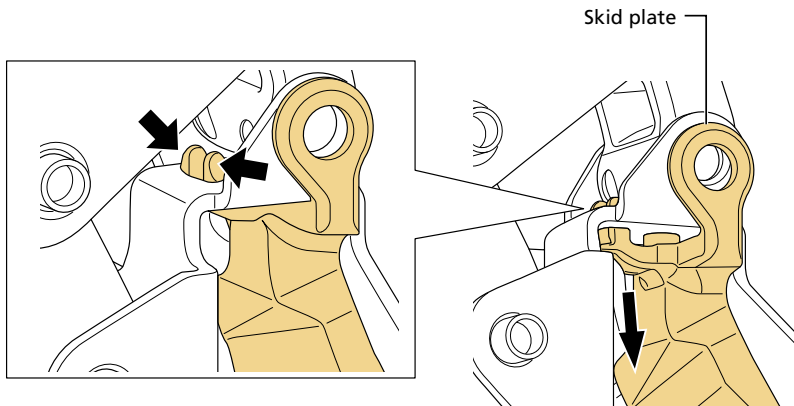

Installing the skid plate

1. Install the skid plate onto the chain guide.

Align the position of the skid plate guide with the round hole of chain guide.

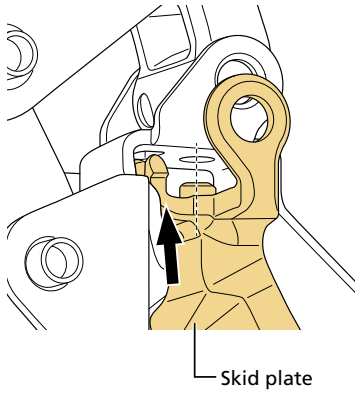

2. Insert the rivet A.

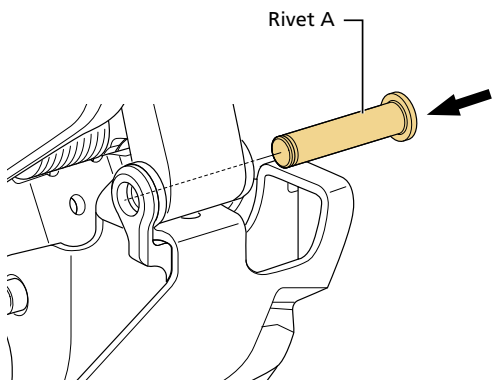

3. Install the snap ring.

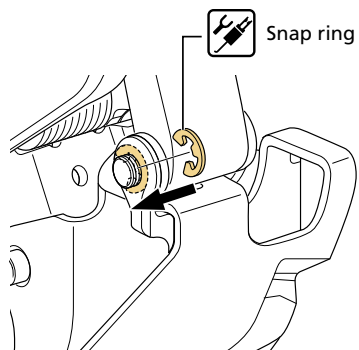

NOTICE

- Do not use the removed snap ring again.

TECH TIPS

- If the snap ring is difficult to install, use a commercially available special tool.

