

Dealer's Manual

ROAD	MTB	Trekking
City Touring/ Comfort Bike	URBAN SPORT	E-BIKE

Hydraulic Disc Brake/ DUAL CONTROL LEVER

DURA-ACE

ST-R9120
BR-R9170
SM-RT900

ULTEGRA

ST-R8020
ST-R8025
BR-R8070
SM-RT800

SHIMANO 105

ST-R7020
ST-R7025
BR-R7070
SM-RT70

TIAGRA

ST-4720
ST-4725
BR-4770

CONTENTS

IMPORTANT NOTICE.....	3
TO ENSURE SAFETY.....	4
LIST OF TOOLS TO BE USED.....	9
INSTALLATION	11
Installation of the disc brake rotor	11
Installation of the brake hose	11
Installation of the brake hose (easy hose joint system).....	17
Installation to the handlebar	29
Adding SHIMANO genuine mineral oil and bleeding air	30
Installing the brake caliper.....	39
Temporary tightening of the frame fixing screws	51
Installation of the shifting cable	52
ADJUSTMENT	57
Free stroke and reach adjustment	57
MAINTENANCE	60
Replacing the brake pads	60
Replacement of the nameplate.....	62
SHIMANO genuine mineral oil replacement.....	62
Replacing the bracket cover	63
Replacing the main lever support	64
Replacing the cable cover.....	66
How to pull out a disconnected inner end (shifting cable).....	67
Replacement of the SL cable guide.....	68
Replacing the diaphragm	69

IMPORTANT NOTICE

- **This dealer's manual is intended primarily for use by professional bicycle mechanics.**
Users who are not professionally trained for bicycle assembly should not attempt to install the components themselves using the dealer's manuals. If any part of the information on the manual is unclear to you, do not proceed with the installation. Instead, contact your place of purchase or a local bicycle dealer for their assistance.
- Make sure to read all instruction manuals included with the product.
- Do not disassemble or modify the product other than as stated in the information contained in this dealer's manual.
- All manuals and technical documents are accessible online at <https://si.shimano.com>.
- For consumers who do not have easy access to the internet, please contact a SHIMANO distributor or any of the SHIMANO offices to obtain a hardcopy of the User's Manual.
- Please observe the appropriate rules and regulations of the country, state or region in which you conduct your business as a dealer.

For safety, be sure to read this dealer's manual thoroughly before use, and follow it for correct use.

The following instructions must be observed at all times in order to prevent personal injury and physical damage to equipment and surroundings. The instructions are classified according to the degree of danger or damage which may occur if the product is used incorrectly.

 **DANGER**

Failure to follow the instructions will result in death or serious injury.

 **WARNING**

Failure to follow the instructions could result in death or serious injury.

 **CAUTION**

Failure to follow the instructions could cause personal injury or physical damage to equipment and surroundings.

TO ENSURE SAFETY

⚠ WARNING

- **Be sure to follow the instructions provided in the manuals when installing the product.**
Only use SHIMANO genuine parts. If a component or replacement part is incorrectly assembled or adjusted, it can lead to component failure and cause the rider to lose control and crash.
-  Wear approved eye protection while performing maintenance tasks such as replacing components.

Be sure to also inform users of the following:

■ Brake

- Because each bicycle may handle slightly differently depending on the model, be sure to learn the proper braking technique (including brake lever pressure and bicycle control characteristics) and operation of your bicycle. Improper use of your bicycle's brake system may result in a loss of control, which could lead to serious injury due to a fall or collision.
- Keep your fingers away from rotating disc brake rotors. Disc brake rotors are sharp enough to severely injure your fingers if caught within the openings of a disc brake rotor.



- Do not touch the calipers and disc brake rotor while riding or immediately after dismounting from the bicycle. The calipers and disc brake rotor will become hot when the brakes are operated, so you may get burned if you touch them.
- Be careful not to allow any oil or grease to get onto the disc brake rotor and brake pads. Riding the bicycle with oil or grease on the disc brake rotor and brake pads may prevent the brakes from operating and result in serious injury due to a fall or collision.
- Check the thickness of the brake pads and do not use them if they have a thickness of 0.5 mm or less. Doing so may prevent the brakes from operating and result in serious injury due to a fall or collision.

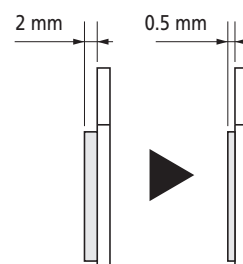

- Do not use the disc brake rotor if it is cracked or deformed. The disc brake rotor may break, and result in serious injury due to a fall or collision.
- Do not use the disc brake rotor if its thickness is 1.5 mm or less. Also do not use it if the aluminum surface becomes visible. The disc brake rotor may break, and result in serious injury due to a fall or collision.
- Do not continuously apply the brakes. Doing so may cause a sudden increase in the brake lever stroke, preventing the brakes from operating and resulting in serious injury due to a fall or collision.
- Do not use the brakes with fluid leaking. Doing so may prevent the brakes from operating and result in serious injury due to a fall or collision.
- Do not apply the front brake too strongly. If you do so, the front wheel may lock and the bicycle may fall forward, and serious injury may result.
- Because the required braking distance will be longer during wet weather, reduce your speed and apply the brakes early and gently. You may fall or collide and be seriously injured.
- A wet road surface may cause tires to lose traction; therefore, to avoid this, reduce your speed and apply the brakes early and gently. If the tires lose traction, it may result in serious injury due to a fall or collision.

For Installation to the Bicycle, and Maintenance:

- Keep your fingers away from rotating disc brake rotors. Disc brake rotors are sharp enough to severely injure your fingers if caught within the openings of a disc brake rotor.



- Do not use the disc brake rotor if it is cracked or warped. The disc brake rotor may break, and result in serious injury due to a fall or collision.

- Do not use the disc brake rotor if its thickness is 1.5 mm or less. Also do not use it if the aluminum surface becomes visible. The disc brake rotor may break, and result in serious injury due to a fall or collision.
- The calipers and disc brake rotor will become hot when the brakes are operated; do not touch them while riding or immediately after dismounting from the bicycle. Otherwise, you may get burned.
- Be careful not to allow any oil or grease to get onto the disc brake rotor and brake pads. Riding the bicycle in that state may prevent the brakes from operating and result in serious injury due to a fall or collision.
- Check the thickness of the brake pads and do not use them if they have a thickness of 0.5 mm or less. Doing so may prevent the brakes from operating and result in serious injury due to a fall or collision.
- Do not use oil other than SHIMANO genuine mineral oil. Doing so may prevent the brakes from operating and result in serious injury due to a fall or collision.
- Use only mineral oil from a container that has been stored in a clean and sealed state. Doing otherwise may prevent the brakes from operating and result in serious injury due to a fall or collision.
- Do not let water or air bubbles get into the brake system. Doing so may prevent the brakes from operating and result in serious injury due to a fall or collision.
- Do not use with a tandem bicycle. Doing so may prevent the brakes from operating and result in serious injury due to a fall or collision.
- When installing the brake caliper using screw fixing pins, be sure to use fixing screws of the appropriate length.
If not, the screw fixing pins may not be securely fastened, and the screws may fall out.

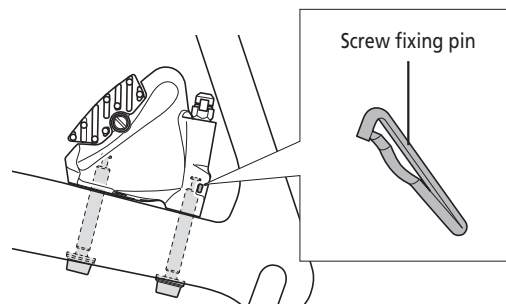

■ Brake hose

- Refer to the table below, and do not use an incorrect connector insert. Doing so may prevent the brakes from operating and result in serious injury due to a fall or collision.

Brake hose	Connector insert	
	Length	Color
SM-BH90-JK-SSR	11.2 mm	Silver

- Do not reuse the olive piece or the connector insert when reinstalling. Doing so may prevent the brakes from operating and result in serious injury due to a fall or collision.

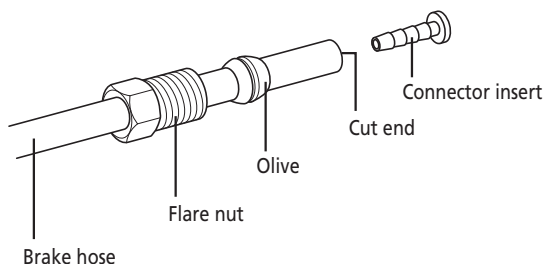

- Cut the brake hose so that the cut end is perpendicular to the length of the hose. If the brake hose is cut at an angle, fluid leaks may result. Fluid leaks may prevent the brakes from operating and result in serious injury due to a fall or collision.





Be sure to also inform users of the following:

■ **Cautions on SHIMANO genuine mineral oil**

- In the event of eye contact, flush with fresh water and seek medical assistance immediately. Contact with eyes may result in irritation.
- Use gloves when handling. In the event of skin contact, wash well with soapy water. Contact with skin may cause a rash and discomfort.
- Cover nose and mouth with a respirator type mask and use in a well ventilated area.
Inhalation of mineral oil mist or vapors may cause nausea. If mineral oil mist or vapor is inhaled, go immediately to an area with fresh air. Cover up with a blanket. Stay warm and stable and seek professional medical advice.

■ **Burn-in period**

- Disc brakes have a burn-in period, and the braking force will gradually increase as the burn-in period progresses. You may lose control of the bicycle, which can result in serious injury due to a fall or collision.
The same thing will happen when the brake pads or disc brake rotor are replaced.

For Installation to the Bicycle, and Maintenance:

■ **Handling SHIMANO genuine mineral oil**

- Do not drink. May cause vomiting or diarrhea.
- Keep out of reach of children.
- Do not cut, let near heat, weld or pressurize the SHIMANO genuine mineral oil container. Doing so may cause an explosion or fire.
- Disposal of used oil: Follow local county and/or state codes for disposal. Use caution when preparing the oil for disposal.
- Directions: Keep the container sealed to prevent foreign objects and moisture from getting inside, and store it in a cool, dark area away from direct sunlight or heat. Keep from heat or flame
- For cleaning brake hoses exposed to mineral oil, or cleaning and maintaining tools, use isopropyl alcohol or a dry cloth. Do not use commercially available brake cleaners. Doing so may cause damage to plastic parts.

■ **Brake hose**

- When cutting the brake hose, handle the knife carefully so as not to cause injury.
- Be careful to avoid injury from the olive.

NOTICE**Be sure to also inform users of the following:**

- Be sure to keep turning the crank during the gear shifting.
- Handle the products carefully, and avoid subjecting them to any strong shocks.
- Do not use the thinners or harsh solvents to clean the products. Such substances may damage the surfaces.
- In the case of carbon levers, wash them with a soft cloth using a neutral detergent. Otherwise, the material may get damaged, and the strength may be affected.
- Avoid leaving the carbon levers in places where high temperatures are present. Also, keep them far away from fire.
- If gear shifting operation does not feel smooth, consult the place of purchase for assistance.
- When the bicycle wheel has been removed, it is recommended that pad spacers are installed. Do not depress the brake lever while the wheel is removed. If the brake lever is depressed without the pad spacers installed, the pistons will protrude further than normal. If that happens, consult a dealer.
- Use soapy water and a dry cloth when cleaning and carrying out maintenance of the brake system. Do not use commercially available brake cleaners or silencing agents, as they can cause damage to parts such as seals.
- Products are not guaranteed against natural wear and deterioration from normal use and aging.
- For maximum performance we highly recommend SHIMANO lubricants and maintenance products.

For Installation to the Bicycle, and Maintenance:

- Use a brake hose/outer casing which still has some length to spare even when the handlebars are turned all the way to both sides. Furthermore, check that the shift lever does not touch the bicycle frame when the handlebars are turned all the way.
- Use an OT-SP cable and cable guide for smooth operation.
- Grease with SIS SP41 grease (Y04180000) the inner cable and the sliding portions of the outer casing before use to ensure that they slide properly. Do not let dust adhere on the inner cable. If the grease on the inner cable is wiped off, the application of SIS SP41 grease (Y04180000) is recommended.
- A special grease is used for the gear shifting cable. Do not use Premium Grease or other types of grease, otherwise they may cause deterioration in gear shifting performance.
- If gear shifting adjustments cannot be carried out, check the alignment of the derailleur hanger and check if the cable is lubricated or if the outer casing is too long or too short.
- Do not remove the lever unit.

■ Disc brake



















- If the brake caliper mounting boss and the dropout are not of standard dimensions, the disc brake rotor and caliper may touch.
- When the bicycle wheel has been removed, it is recommended that pad spacers are installed. The pad spacers will prevent the piston from coming out if the brake lever is depressed while the wheel is removed.
- If the brake lever is depressed without the pad spacers installed, the pistons will protrude further than is normal. Use a slotted screwdriver or similar tool to push back the brake pads, while being careful not to damage the surfaces of the brake pads. (If the brake pads are not installed, use a flat-shaped tool to push the pistons straight back in, while being careful not to damage them)
If it is difficult to push the brake pads or pistons back, remove the bleed screws and then try again. (Note that some oil may overflow from the reservoir tank at this time.)
- Use isopropyl alcohol, soapy water or a dry cloth when cleaning and carrying out maintenance of the brake system. Do not use commercially available brake cleaners or silencing agents. They can cause damage to parts such as seals.
- Do not remove the pistons when cleaning the calipers.
- If the disc brake rotor is worn, cracked or warped, it should be replaced.
- The clamp band, clamp bolt, and clamp nut are not compatible with other products. Do not use with components that are used in other products.

The actual product may differ from the illustration because this manual is intended chiefly to explain the procedures for using the product.

LIST OF TOOLS TO BE USED

LIST OF TOOLS TO BE USED

The following tools are needed for installation, adjustment, and maintenance purposes.

Tool		Tool		Tool	
	2 mm hexagon wrench		Screwdriver [#1]		TL-CT12
	2.5 mm hexagon wrench		Slotted screwdriver (nominal dia. 0.8 x 4)		SM-DISC (Oil funnel and oil stopper)
	4 mm hexagon wrench		Adjustable wrench		Funnel adapter
	5 mm hexagon wrench		Utility knife		TL-BT03 / TL-BT03-S
	8 mm spanner		TL-BH61		TL-LR15
	7 mm box wrench		TL-BH62		Hexalobular [#8]
	Micrometer				

INSTALLATION

INSTALLATION

■ Installation of the disc brake rotor

Center lock type

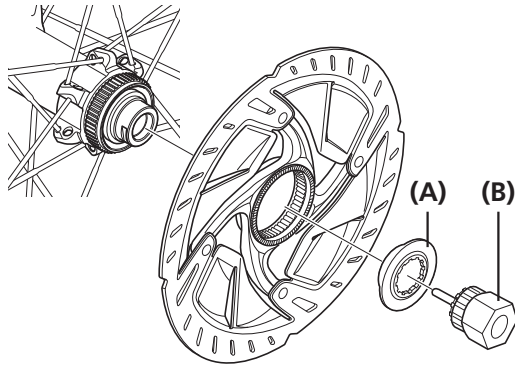

- (A) Disc brake rotor lock ring
- (B) Lock ring tightening tool

Tightening torque

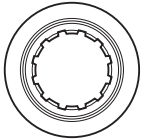

40 N·m

	Internal spline type
Disc brake rotor lock ring	
Lock ring tightening tool	TL-LR15 Adjustable wrench

■ Installation of the brake hose

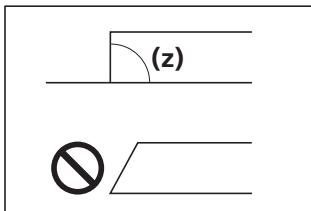

Use a utility knife or other cutting tool to cut the brake hose.

(z) 90°

NOTICE

Use the utility knife safely and correctly in accordance with its instruction manual.



TECH TIPS

If you are using TL-BH62, refer to the Service instruction accompanying the product.

1

2

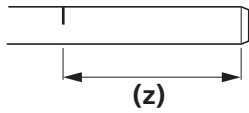

Put a mark on the brake hose beforehand as shown in the illustration so that you can check if the ends of the brake hose are secured to the hose mounts of the brake caliper and the dual control lever.
(As a guide, the length of the portion of the brake hose that is inside the mount is approximately 15 mm.)

(z) 15 mm

3

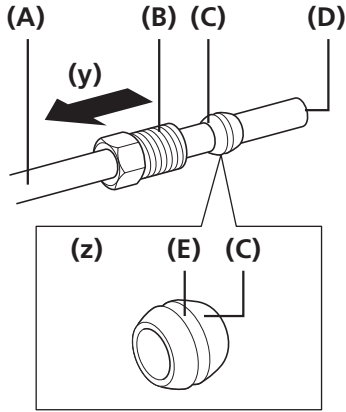

Pass the brake hose through the flare nut and olive as shown in the figure.

- (y)** Direction of insertion
- (z)** Grease the outside of the olive.

Dual control lever end

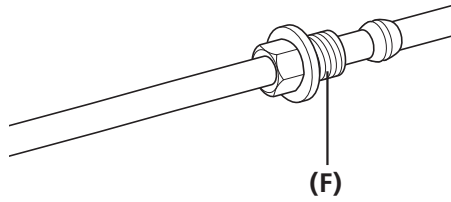

Brake caliper end

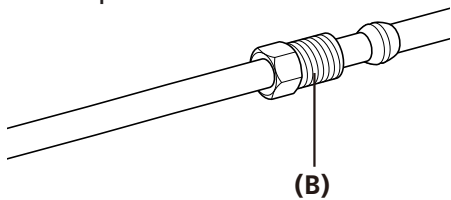

- (A)** Brake hose
- (B)** Flare nut
- (C)** Olive
- (D)** Cut end
- (E)** Grease
- (F)** Flare nut with flange

NOTICE

- For installation to the built-in type frame, first connect to the frame caliper the end of the brake hose to which the banjo is not attached.
- Use a flare nut with flange on the dual control lever end.

4

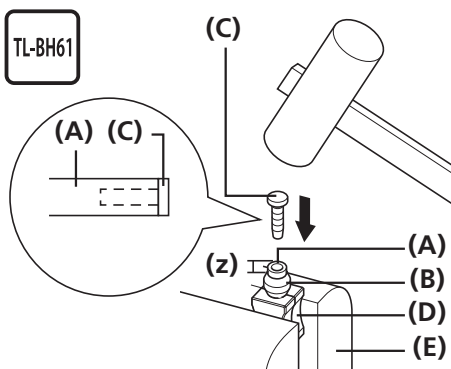

Use a tapered tool to smooth out the inside of the cut end of the brake hose, and mount the connector insert.

Connect the brake hose to TL-BH61 and secure TL-BH61 in a vise, as shown in the illustration.

Then, hammer down the connector insert until the connector insert mount comes into contact with the end of the brake hose.

(z) SM-BH90-JK-SSR: 1 mm

- (A)** Brake hose
- (B)** Olive
- (C)** Connector insert
- (D)** TL-BH61
- (E)** Vise

NOTICE

If the end of the brake hose is not in contact with the connector insert mount, the brake hose may be disconnected or cause fluid leaks.

5

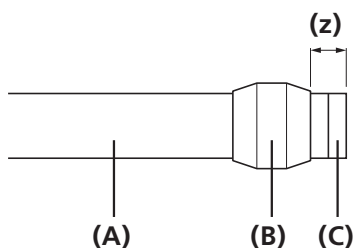

After checking that the olive is positioned as shown in the illustration, grease the screw threads of the flare nut.

(z) 2 mm

- (A)** Brake hose
- (B)** Olive
- (C)** Connector insert

NOTICE

Use the dedicated connector insert supplied with SM-BH90-JK-SS.

Use of any connector insert other than the one supplied may produce a loose assembly, leading to oil leaks or other problems.

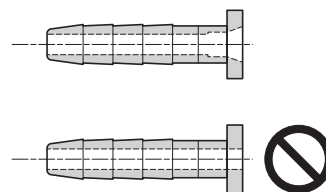

Model No.	Length	Color
SM-BH90-JK-SSR	11.2 mm	Silver

Make sure that the brake hose is not twisted.

Make sure that the brake calipers and dual control levers are in the positions shown in the illustrations.

6

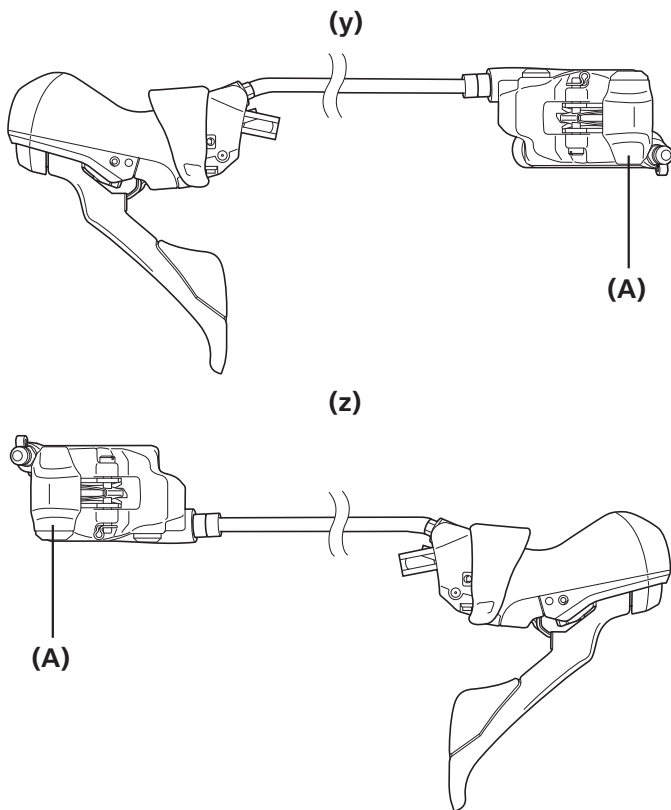

(y) Left lever

(z) Right lever

(A) Brake caliper

7

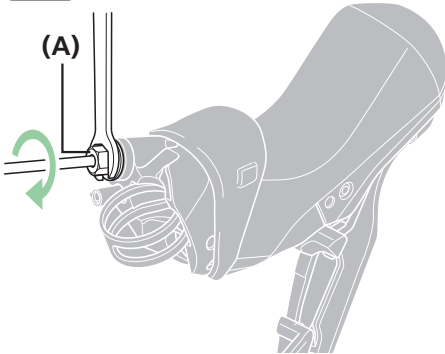

Secure the dual control lever to the handlebar or in a vise and insert the brake hose straight.

Tighten the flare nut with flange with a spanner while pushing the brake hose.

(A) Flare nut with flange

Tightening torque



5 - 6 N·m

NOTICE

- At this point, make sure the brake hose is straight when pushing.
- When installing the brake hose with the dual control lever secured to the handlebar, adjust the angle of the bracket to make it easier to turn the spanner. At that time, be careful not to damage the handlebar and other parts.

INSTALLATION

▶▶ Installation of the brake hose

8

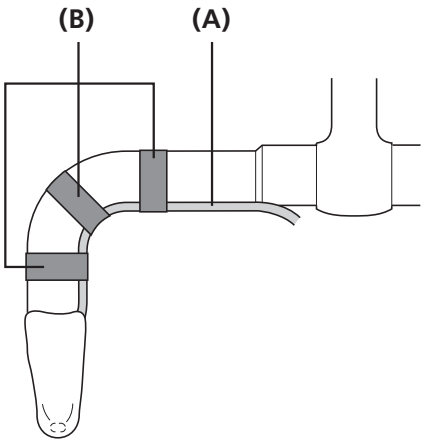

Temporarily secure the brake hose to the handlebar (by using tape or similar material).

(A) Brake hose

(B) Tape

INSTALLATION

Installation of the brake hose

End of the brake hose on the brake caliper side

Attach the connector insert to the brake hose.

Then, tighten the flare nut to the caliper while pushing the brake hose.

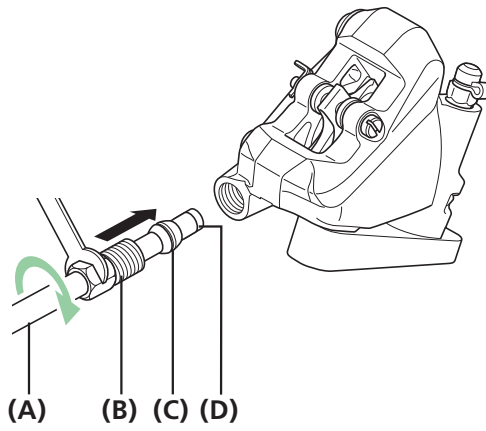

- (A) Brake hose
- (B) Flare nut
- (C) Olive
- (D) Connector insert

Tightening torque



5 - 7 N·m

■ Installation of the brake hose (easy hose joint system)

This section covers procedures for cutting and adjusting the lengths of easy hose joint system brake hoses.
If length adjustment of a brake hose is not necessary, it is not necessary to follow procedures relating to cutting the brake hose.

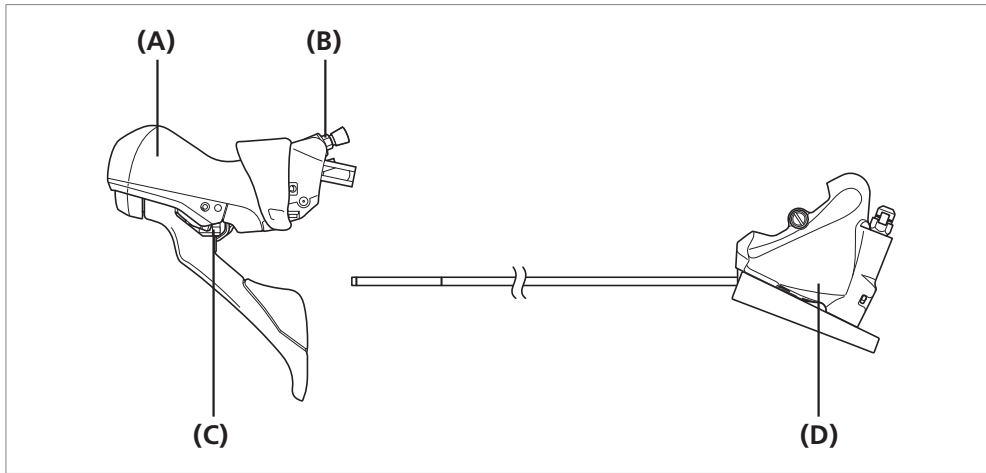

- (A)** Dual control lever
- (B)** Joint sleeve
- (C)** Lever stopper
- (D)** Brake caliper

Pass the brake hose through each hole in the internal frame.

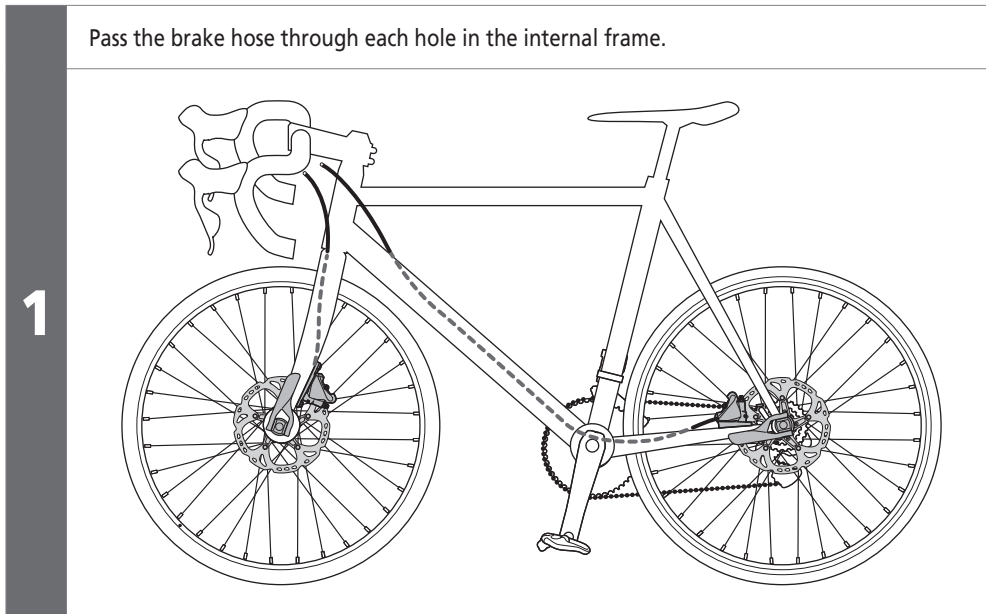

NOTICE

The illustration is a rough image.
For details on routing the brake hoses, consult the manufacturer of the completed bicycle or refer to the owner's manual for the bicycle.

INSTALLATION

Installation of the brake hose (easy hose joint system)

Secure the dual control levers in the installation positions to be used when riding.

Check the appropriate length for each brake hose by running the brake hose along the handlebar as in the following illustration.

2

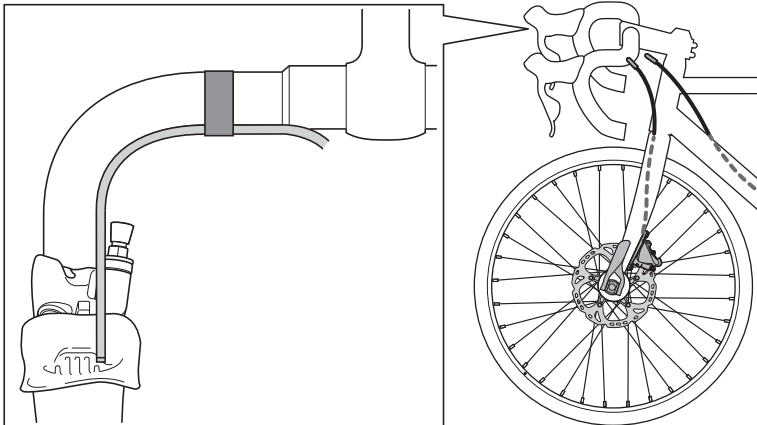

3

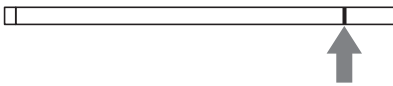

When the appropriate length has been determined, mark the brake hose.

4

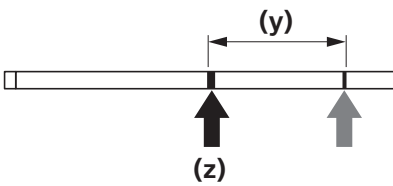

Mark the brake hose again 21 mm away from the first mark to indicate where the brake hose should be cut.

(y) 21 mm

(z) Mark for cutting

TECH TIPS

When checking the appropriate lengths for the brake hoses, use the head of the flare nut on the dual control lever as a guideline.

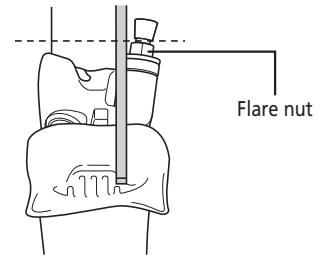

NOTICE

Easy hose joint system brake hoses are pre-marked. If it is not necessary to cut the brake hose in order to adjust its length, it is not necessary to mark the hose.

INSTALLATION

Installation of the brake hose (easy hose joint system)

Orient the brake hose connection port of the dual control lever securely upward by changing the angle of the handlebars or another means.

5

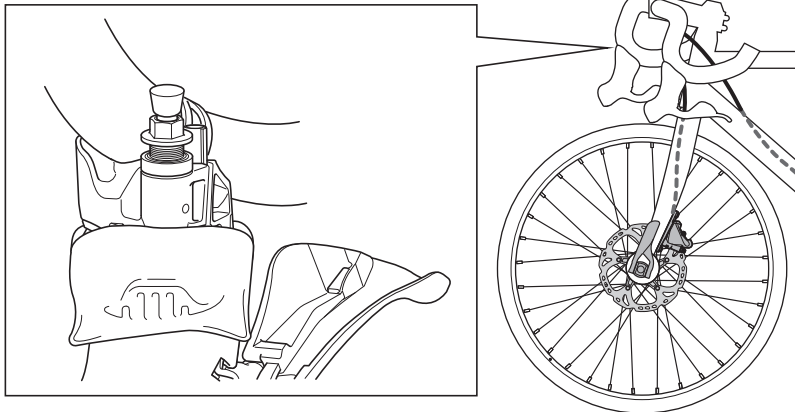

NOTICE

When installing the brake hose with the dual control lever secured to the handlebar, adjust the angle of the bracket to make it easier to turn the spanner.

At that time, be careful not to damage the handlebar and other parts.

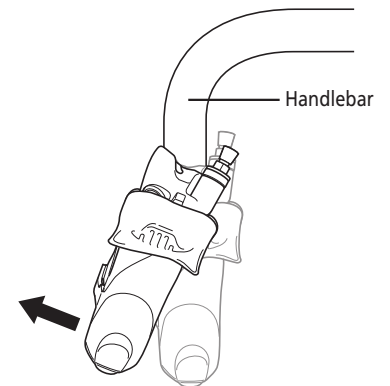

Prepare tool TL-BH62 for the cutting of the brake hose.

Disassemble TL-BH62 as shown in the figure below.

6

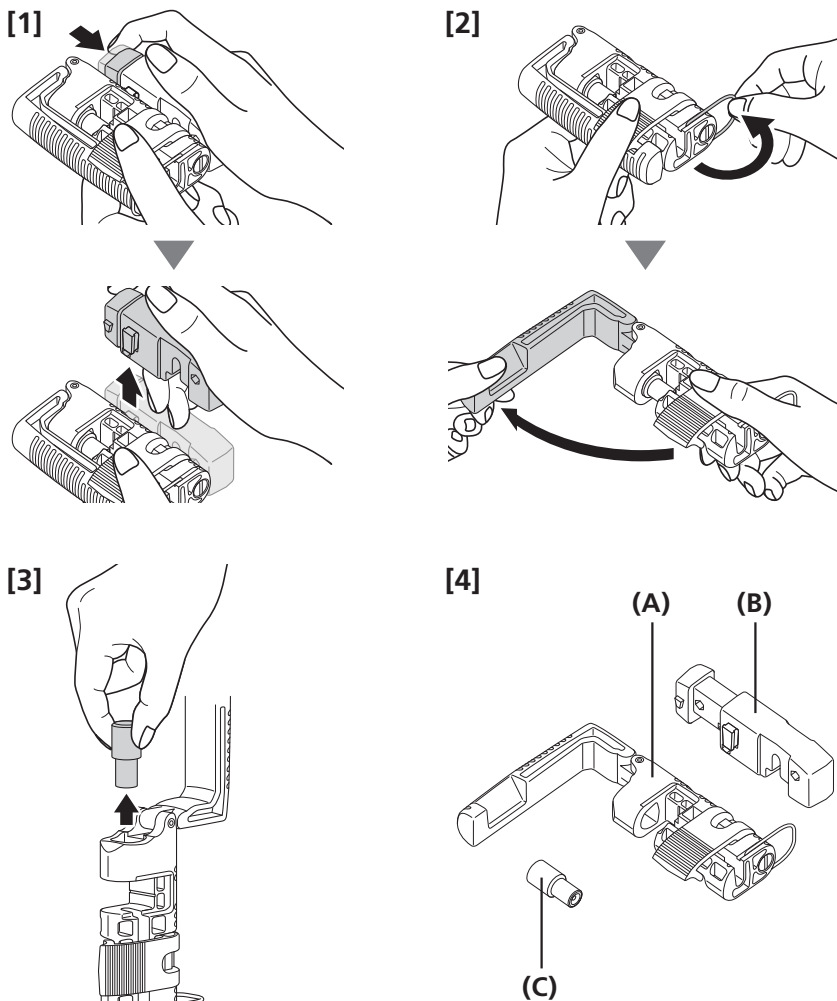

- (A) Body of tool
- (B) Hose cutter
- (C) Press block

NOTICE

- Do not move the lever indicated in the figure before disassembling TL-BH62.

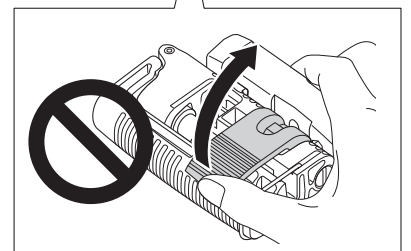
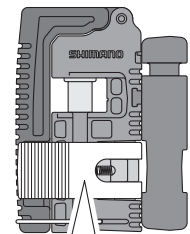

- Make sure to also refer to the manual for TL-BH62.

▶ Installation of the brake hose (easy hose joint system)

Insert the brake hose into the tool as shown in the illustration.

Next, check that the cut mark is level with the groove on the tool, and then secure the brake hose in place.

[1]

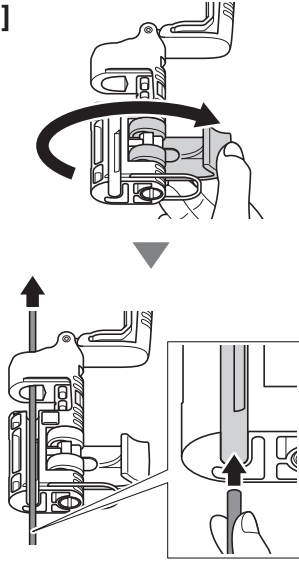

[2]

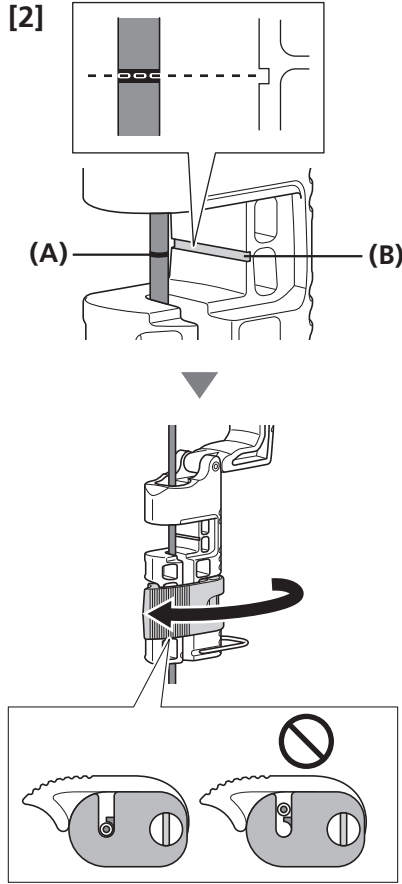

(A) Cut mark

(B) Groove

NOTICE

When inserting the brake hose into the tool, align the mark for cutting with the groove in the tool.

7

Check that the hose is secure and then attach the hose cutter.

Press the hose cutter as shown in illustration [2] to cut the brake hose.

[1]

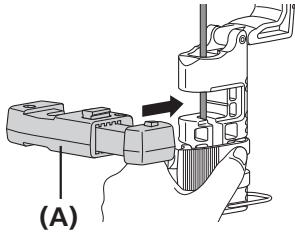

[2]

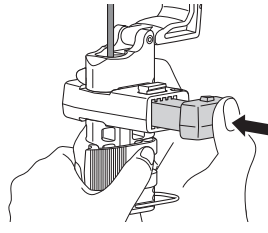

(A) Hose cutter

8

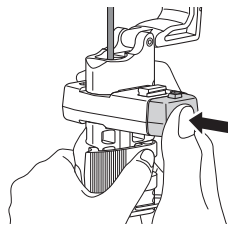
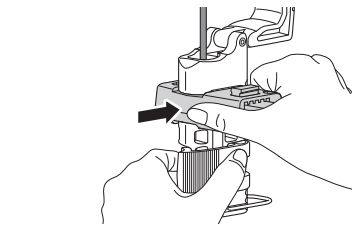

9

Detach the hose cutter and check that the cut end is horizontal.

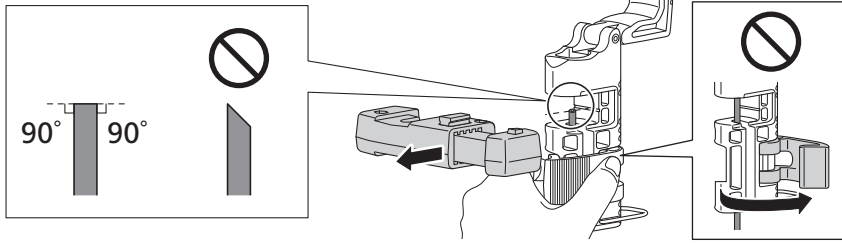

Prepare the connector insert for insertion into the brake hose as follows.

Attach the connector insert to the press block and then set the press block in the tool.

Make sure that the tip of the connector insert is correctly positioned inside the opening of the brake hose.

- (A) Press block
- (B) Connector insert

10

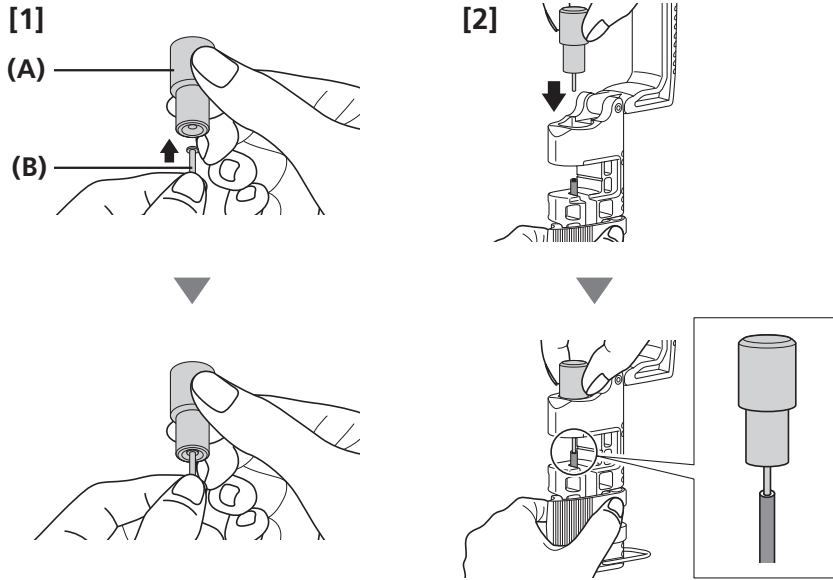

▶ Installation of the brake hose (easy hose joint system)

11

Grip the lever on the tool to insert the connector insert into the brake hose, as shown in the illustrations.

Check that the connector insert has been inserted correctly, and then remove the brake hose from the tool.

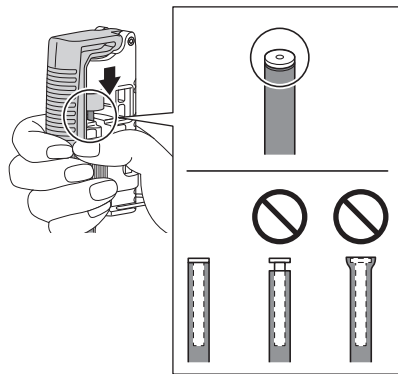
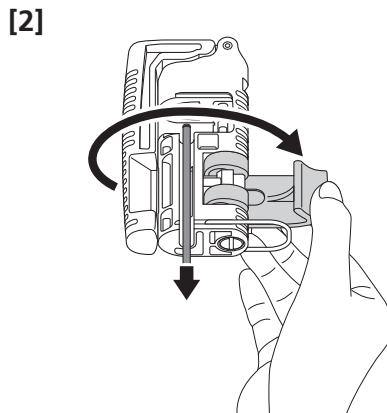
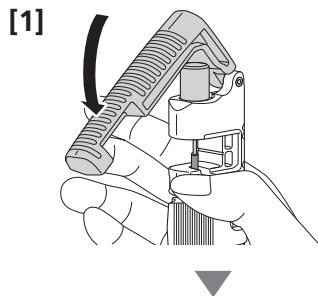

12

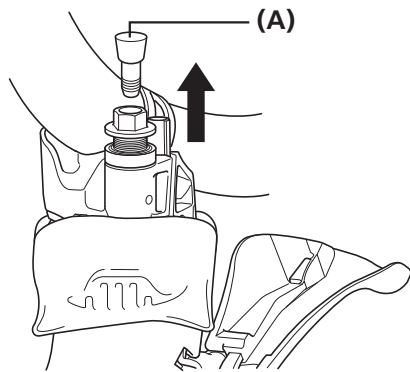

Remove the seal plug.

(A) Seal plug



TECH TIPS

Cover the seal plug with a clean rag as the oil applied to the seal plug may leak.

13

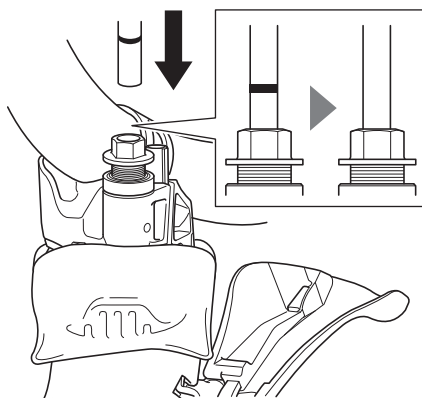

Insert the brake hose into the joint component until the mark on the hose is hidden.



TECH TIPS

- It comes with a built-in olive. Insert it while making sure that it will not get snagged on the olive.
- Check that the brake hose is inserted until the line printed on it or the mark made previously are hidden.
- Use a clean rag when inserting the brake hose as some oil inside may leak.

▶ Installation of the brake hose (easy hose joint system)

14

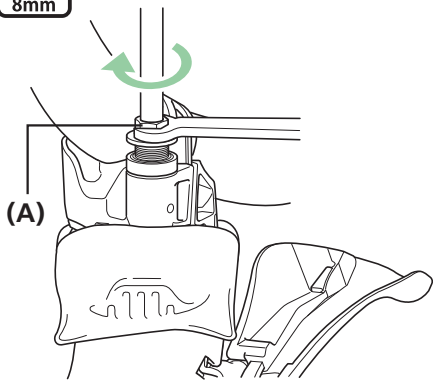

Tighten the flare nut with flange with an 8 mm spanner while pushing in the brake hose.

Then, wipe off any oil residue.

(A) Flare nut with flange

Tightening torque



5 - 6 N·m

NOTICE

Make sure that the brake hose is inserted properly and the flare nut is tightened correctly. Oil leakage or inadequate braking power may result.

15

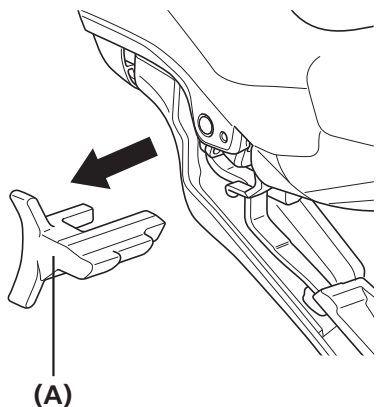

Remove the brake lever stopper.

(A) Lever stopper

NOTICE

After removing the lever stopper, check that the pad spacer is installed on the caliper side or that the caliper is installed to the bicycle and the disc brake rotor is between the two sides of the caliper, before depressing the lever. After installation to the bicycle, make sure to check that the lever stopper is removed.



TECH TIPS

Move and pull on the lever stopper to remove it while being careful not to depress the lever.

16

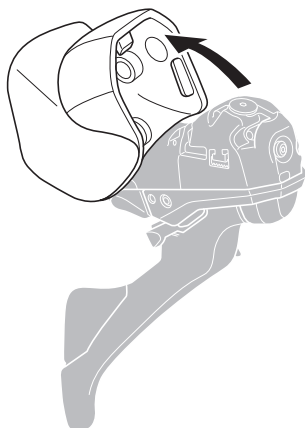

Pull back the bracket cover from the front.

▶ Installation of the brake hose (easy hose joint system)

17

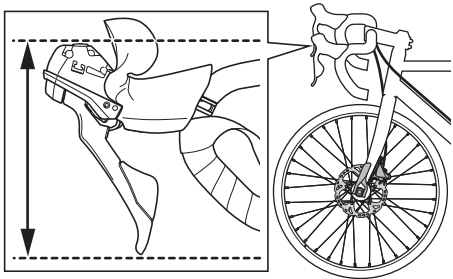

Adjust the position of the bleed screw so that its surface is parallel to the ground.

NOTICE

When tilting, be careful not to forcibly pull on the brake hose or shifting cable.

18

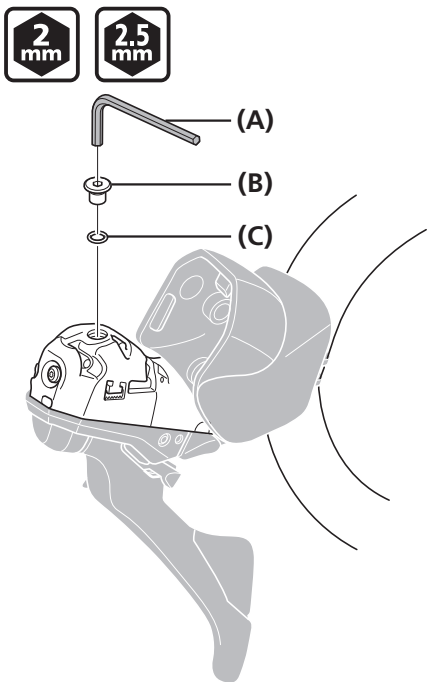

Remove the bleed screw and O-ring.

(A) ST-R9120 / ST-R8020 / ST-R8025:
2 mm hexagon wrench
ST-R7020 / ST-R7025 / ST-4720 /
ST-4725:
2.5 mm hexagon wrench

(B) Bleed screw

(C) O-ring



TECH TIPS

Be careful not to drop the bleed screw or O-ring.

19

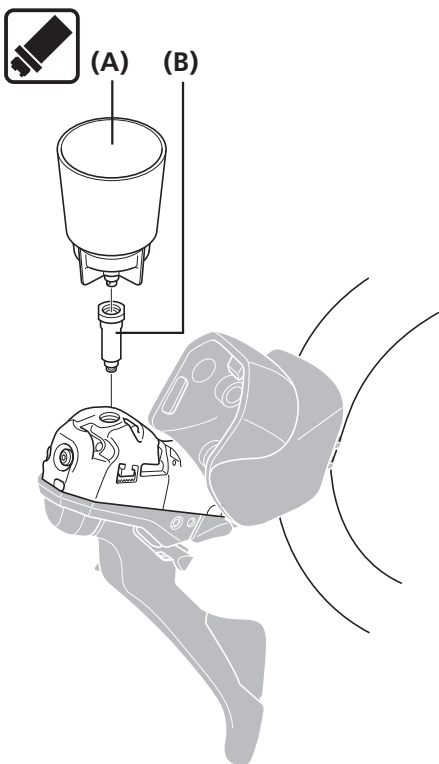

Attach the funnel adapter to the oil funnel.

(A) Oil funnel

(B) Funnel adapter

INSTALLATION

Installation of the brake hose (easy hose joint system)

20

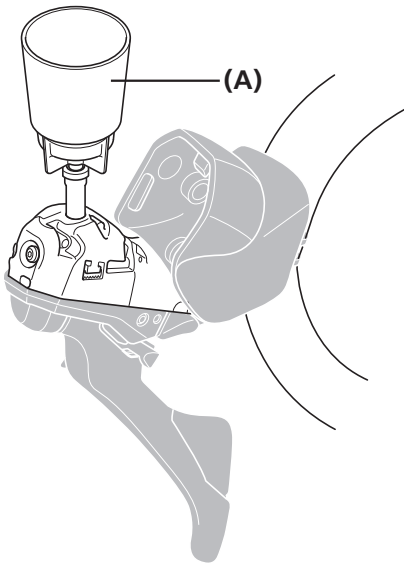

Mount the oil funnel.

(A) Oil funnel

21

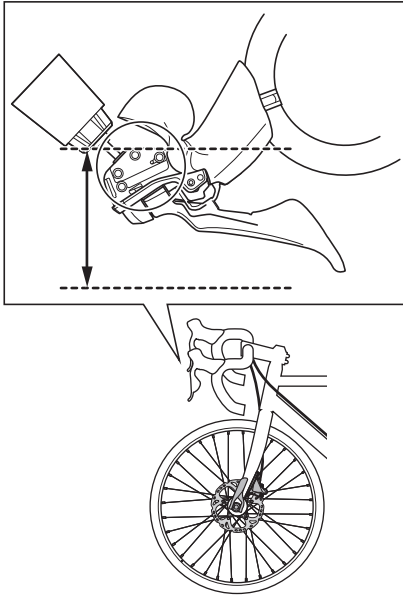

Make adjustments, such as changing the angle of the handlebar, so that the side of the bracket indicated in the illustration is parallel to the ground.

NOTICE

When tilting, be careful not to forcibly pull on the brake hose or shifting cable.

22

Secure the brake caliper with a clip while bleeding.

23

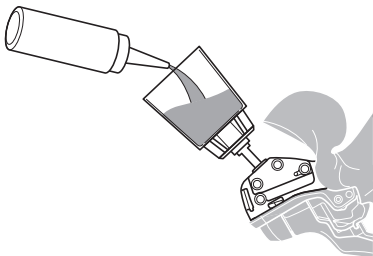

Fill the oil funnel with oil.

Installation of the brake hose (easy hose joint system)

24

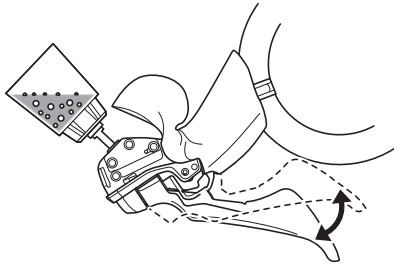

Slowly apply and release the lever until no more air bubbles are emitted.

25

Make adjustments, such as changing the angle of the handlebar, so that the side of the bracket indicated in the illustration is 45° to the ground, and slowly apply and release the lever until no more air bubbles are emitted.

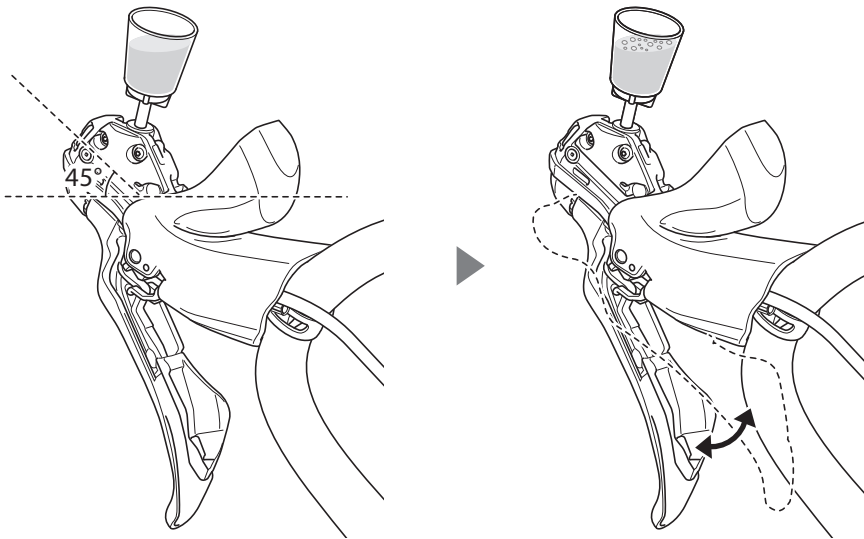

▶ Installation of the brake hose (easy hose joint system)

If the brake lever is then operated, air bubbles in the system will rise up through the port into the oil funnel.

Once the bubbles stop appearing, depress the brake lever as far as it will go.

Under the normal condition, the lever action should feel stiff at this point.

- (x)** Loose
- (y)** Slightly stiff
- (z)** Stiff

26

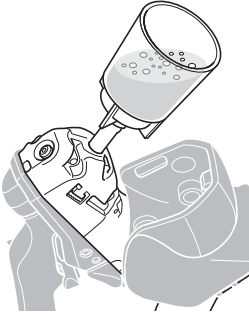

Lever operation

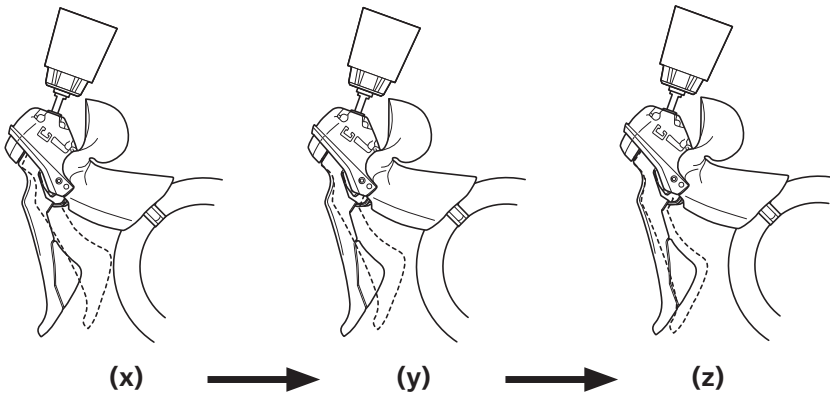

27

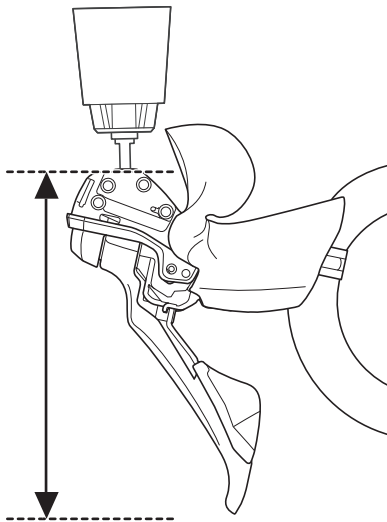

Make adjustments, such as changing the angle of the handlebar, so that the head of the bleed screw is parallel to the ground.

▶ Installation of the brake hose (easy hose joint system)

28

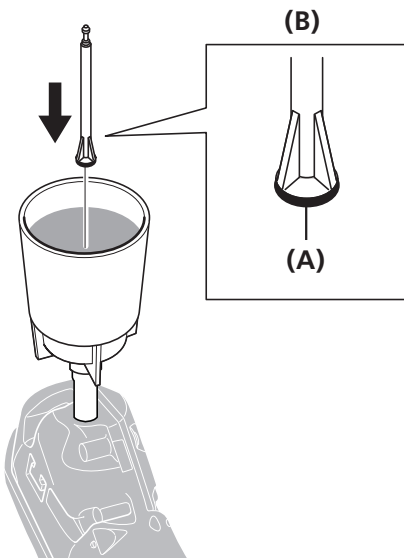

Plug the oil funnel with the oil stopper so that the O-ring mounted side is facing downward.

- (A) O-ring
- (B) Oil stopper

29

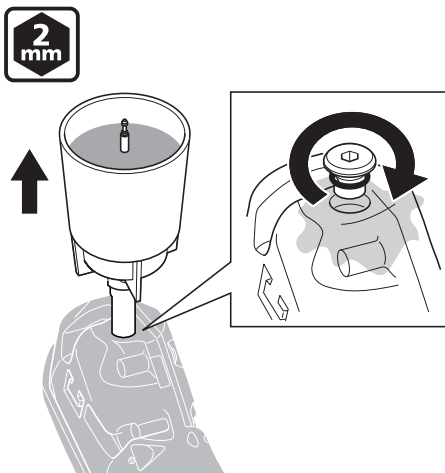

Remove the oil funnel and funnel adapter while still plugged with the oil stopper.

Attach the O-ring to the bleed screw and tighten it while letting oil flow out so as to make sure that no air bubbles remain inside the reservoir tank.

Tightening torque



0.5 - 0.7 N·m

NOTICE

Do not operate the brake lever. Otherwise, air bubbles may enter the cylinder.



Use a clean rag to prevent the oil from flowing to surrounding areas.

30

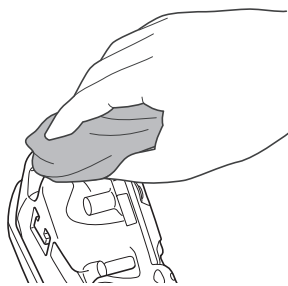

Wipe away any oil which has flowed out.

NOTICE

After completing all procedures, make sure to check that the brakes work correctly.

■ Installation to the handlebar

1

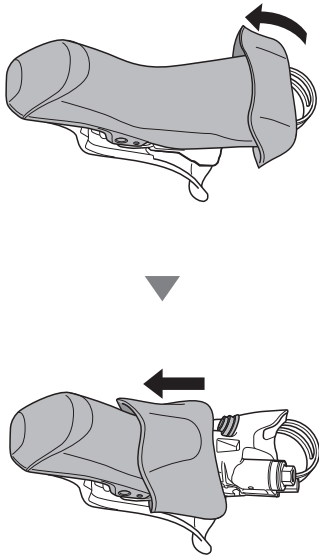

Turn over the bracket cover from the back side.

Gently turn over the ends of the bracket cover with both hands and slowly push them down.

NOTICE

Forcibly pulling it may cause damage to the bracket cover because of its material properties.

2

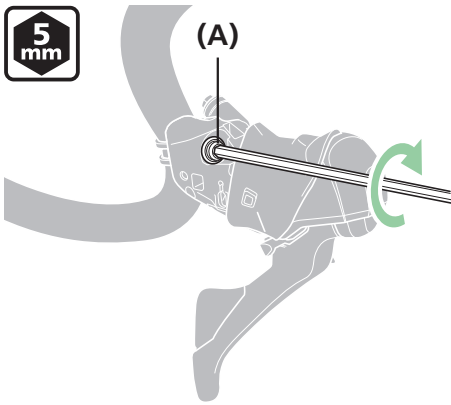

Use a 5 mm hexagon wrench to loosen the clamp bolt at the upper section of the bracket then tighten it after setting it on the handlebar.

(A) Clamp bolt

Tightening torque	
	6 - 8 N·m

NOTICE

- When mounting the shift lever to a drop handlebar, loosen the clamp bolt sufficiently. Otherwise, the handlebar may be damaged.
- The clamp band, clamp bolt, and clamp nut are not compatible with other products. Do not use with components that are used in other products.

INSTALLATION

▶ Adding SHIMANO genuine mineral oil and bleeding air

■ Adding SHIMANO genuine mineral oil and bleeding air

With the bleed spacer (yellow) attached to the brake caliper, place the bicycle in the work stand as shown in the illustration.

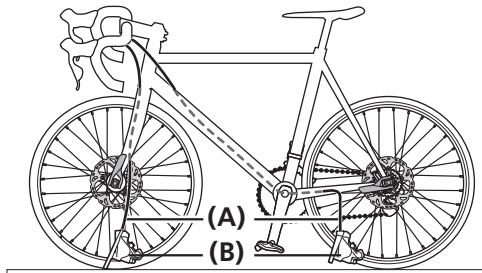

- (A) Brake hose
- (B) Brake caliper

NOTICE

When bleeding the brake caliper, SM-DISC (oil funnel and oil stopper) and the funnel adapter are required.

1

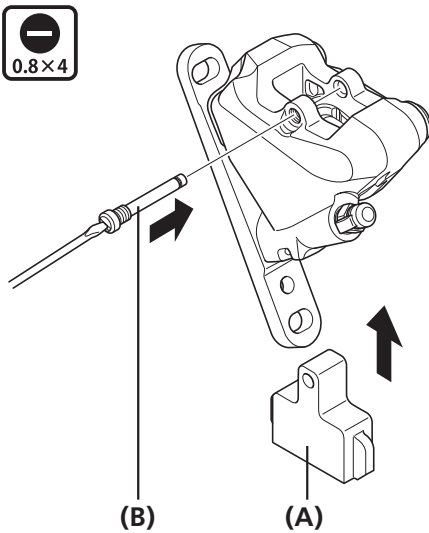

Mount the bleed spacer (yellow).

- (A) Bleed spacer
- (B) Pad axle

Tightening torque



0.2 - 0.4 N·m

2

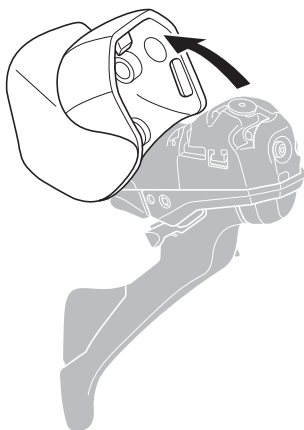

Pull back the bracket cover from the front.

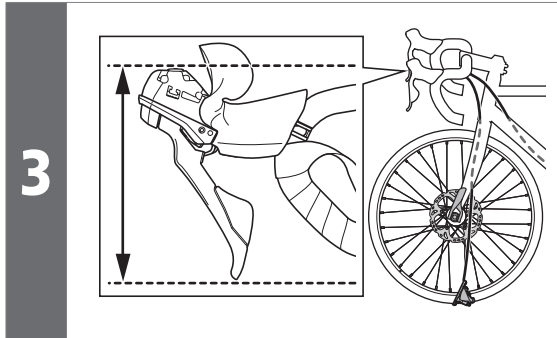

Adjust the position of the bleed screw so that its surface is parallel to the ground.

NOTICE

When tilting, be careful not to forcibly pull on the brake hose or shifting cable.

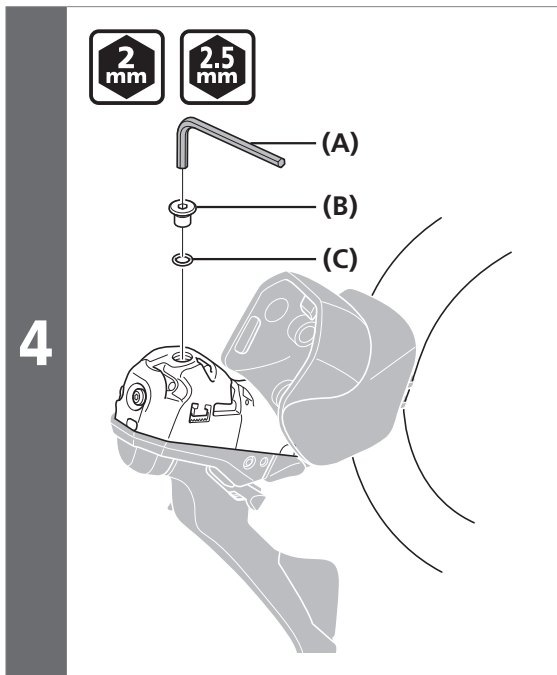

Remove the bleed screw and O-ring.

- (A)** ST-R9120 / ST-R8020 / ST-R8025:
2 mm hexagon wrench
ST-R7020 / ST-R7025 / ST-4720 /
ST-4725:
2.5 mm hexagon wrench
- (B)** Bleed screw
- (C)** O-ring

 **TECH TIPS**

Be careful not to drop the bleed screw or O-ring.

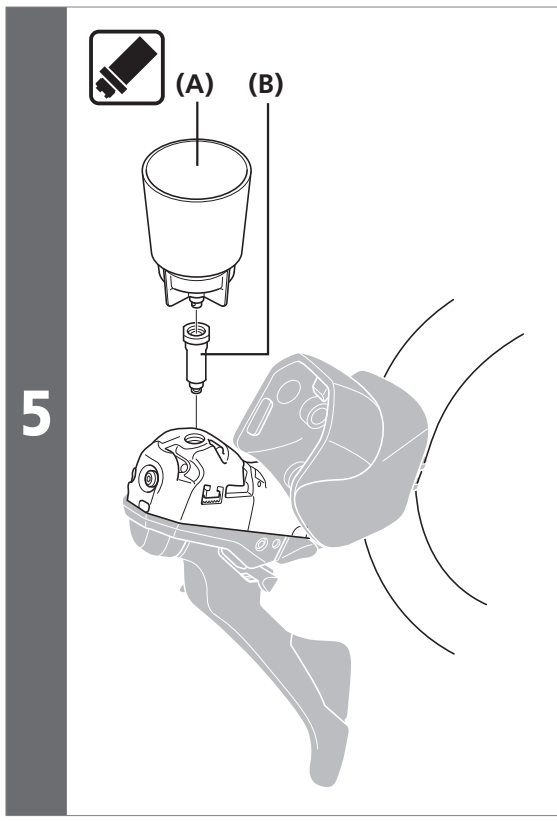

Attach the funnel adapter to the oil funnel.

- (A)** Oil funnel
- (B)** Funnel adapter

6

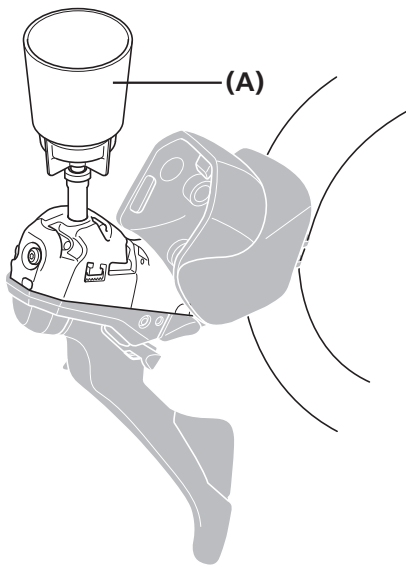

Mount the oil funnel.

(A) Oil funnel

7

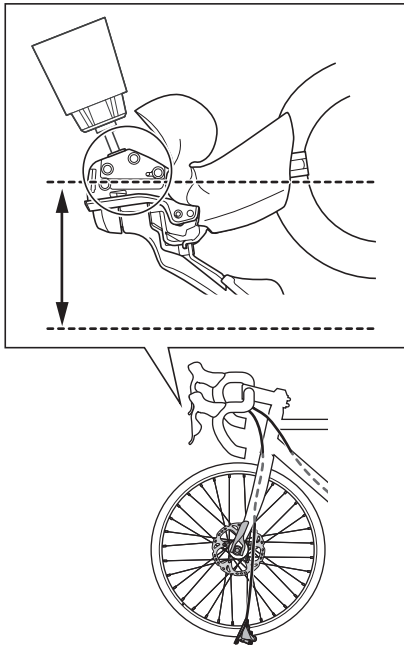

Make adjustments, such as changing the angle of the handlebar, so that the side of the bracket indicated in the illustration is parallel to the ground.

NOTICE

When tilting, be careful not to forcibly pull on the brake hose or shifting cable.

8

Secure the brake caliper with a clip while bleeding.

9

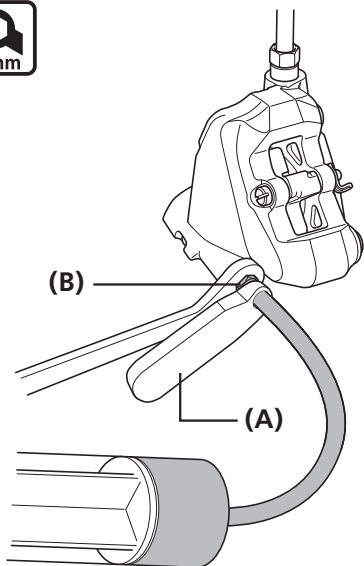

Set a 7 mm box wrench in place.

Fill the syringe with sufficient oil, connect the syringe tube to the bleed nipple, and fasten it with the tube holder so that the tube will not be disconnected.

Loosen the bleed nipple by a 1/8 of a turn to open it.

- (A) Tube holder
- (B) Bleed nipple

NOTICE

If possible, secure the caliper body to prevent the tube from being accidentally disconnected.

Do not depress and release the lever repeatedly.

Oil without air bubbles may come out as a result of such operation, but air bubbles may remain in the oil inside the brake caliper, and it will take longer to bleed the air. (If you have depressed and released the lever repeatedly, drain out all of the oil and then add oil again.)

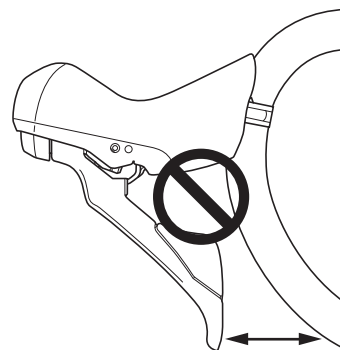

10

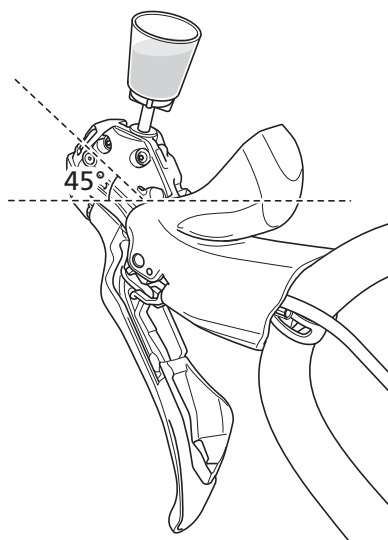

Once there are no more air bubbles in the oil in the funnel, change the angle of the handles so that bracket is 45° as shown in the illustration.

In this state, insert oil into the funnel until there are no more air bubbles in the oil in the funnel, and then temporarily close the bleed nipple.

Remove the syringe while covering the end of the syringe tube with a clean rag to prevent oil from spattering.

11

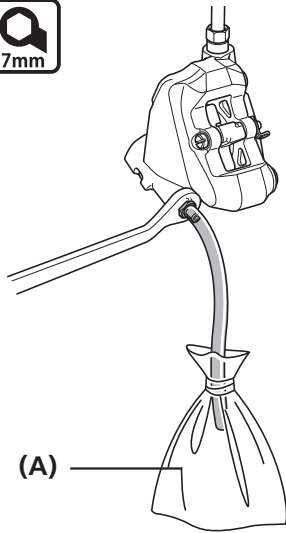

Tie the supplied tube and bag with rubber bands.

Set a 7 mm box wrench as shown in the illustration, and connect the tube to the bleed nipple.

(A) Bag

12

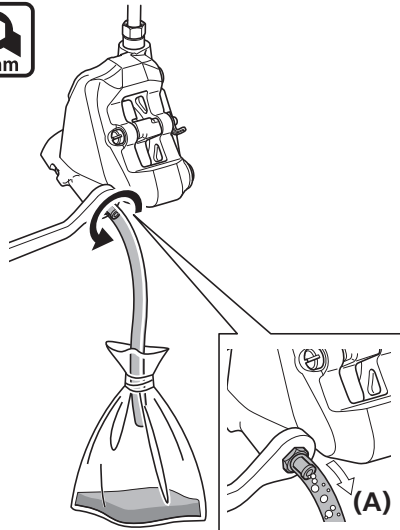

Loosen the bleed nipple.

At this point, make sure that the tube is secured to the bleed nipple.

After a little while, the oil and air bubbles will flow naturally from the bleed nipple into the tube.

In this way it will be possible to easily extract the greater part of the air bubbles remaining inside the brake system.

(A) Air bubbles

TECH TIPS

It may be effective to shake the brake hose gently, to tap the lever bracket or brake calipers gently with a screwdriver, or to move the position of the calipers at this time.

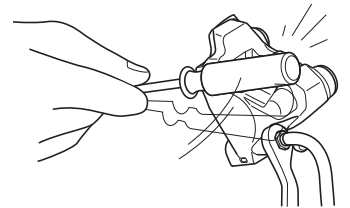

13

The level of liquid inside the oil funnel drops at this time, so keep filling the funnel with oil to maintain the level of liquid so that air is not drawn in.



14



7mm

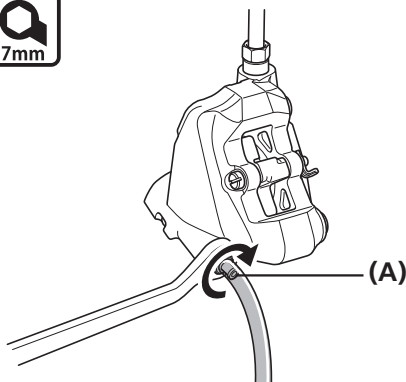

(A)

Once no more air bubbles come from the bleed nipple, temporarily close the bleed nipple.

(A) Bleed nipple

15

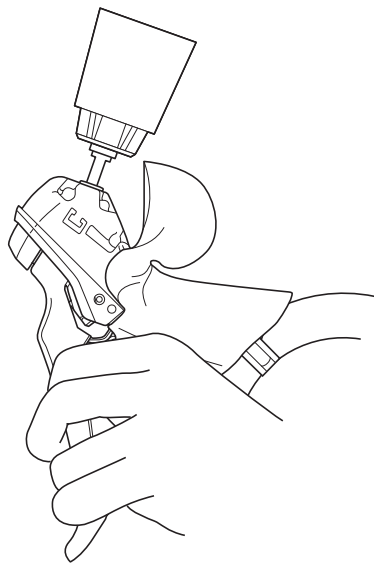

With the brake lever depressed, open and close the bleed nipple in rapid succession (for approximately 0.5 seconds each time) to release any air bubbles which may be in the brake calipers.

Repeat this procedure about 2 to 3 times.

16



7mm

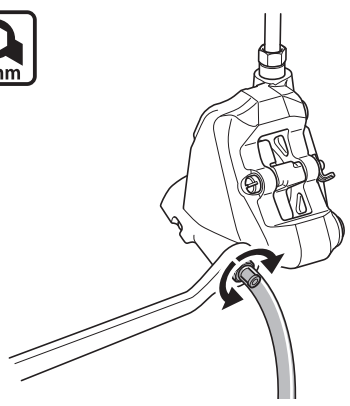

Tighten the bleed nipple.

Tightening torque	
 <p>7mm</p>	4 - 7 N·m

▶ Adding SHIMANO genuine mineral oil and bleeding air

Make adjustments, such as changing the angle of the handlebar, so that the side of the bracket indicated in the illustration is parallel to the ground, and slowly apply and release the lever until no more air bubbles are emitted.

17

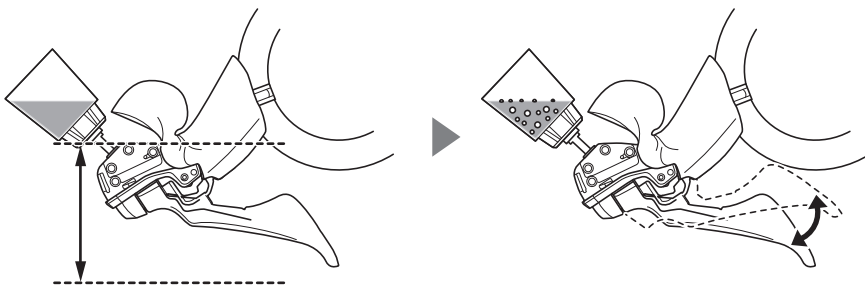

Make adjustments, such as changing the angle of the handlebar, so that the side of the bracket indicated in the illustration is 45° to the ground, and slowly apply and release the lever until no more air bubbles are emitted.

18

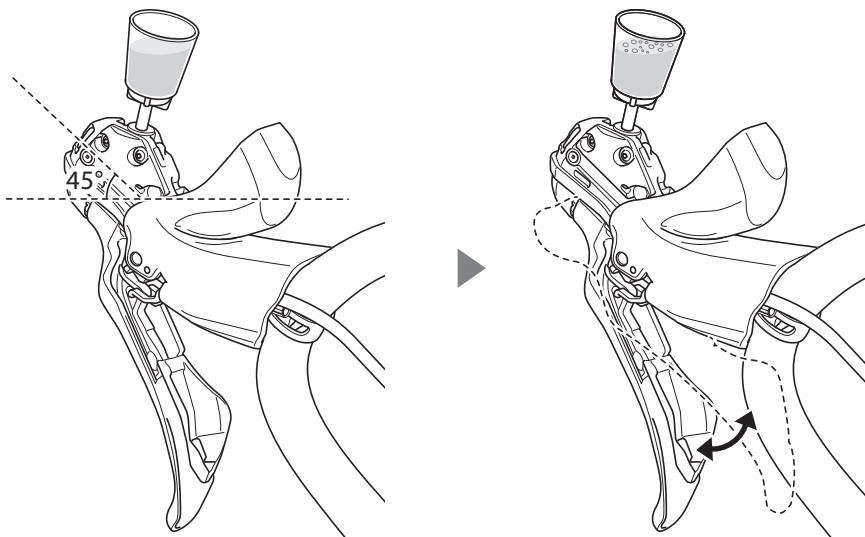

⚠ WARNING

Make sure to set the lever to the specified position before bleeding air. If you bleed air without setting the lever to the specified position, air bubbles may remain in the brake system. Air bubbles remaining in the brake system may prevent the brakes from operating and result in serious injury due to a fall or collision.

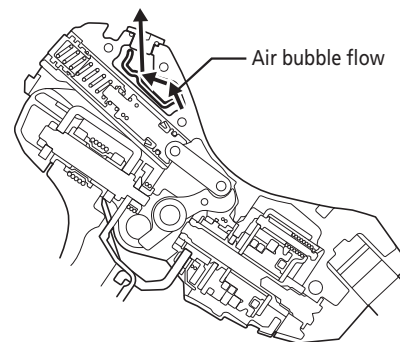

If the brake lever is then operated, air bubbles in the system will rise up through the port into the oil funnel.

Once the bubbles stop appearing, depress the brake lever as far as it will go.

Under the normal condition, the lever action should feel stiff at this point.

- (x)** Loose
- (y)** Slightly stiff
- (z)** Stiff

19

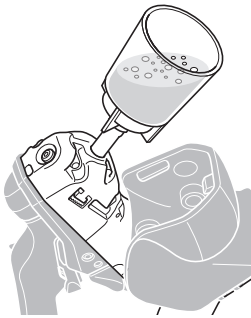

Lever operation

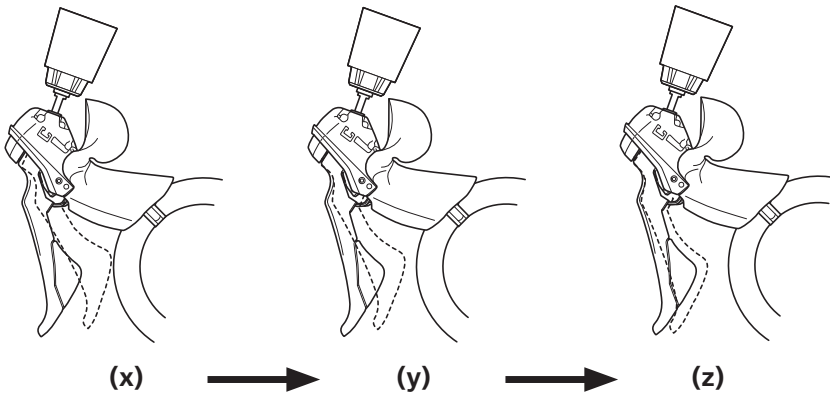

20

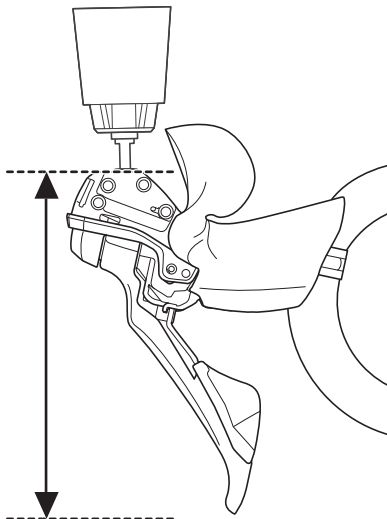

Make adjustments, such as changing the angle of the handlebar, so that the head of the bleed screw is parallel to the ground.

▶ Adding SHIMANO genuine mineral oil and bleeding air

21

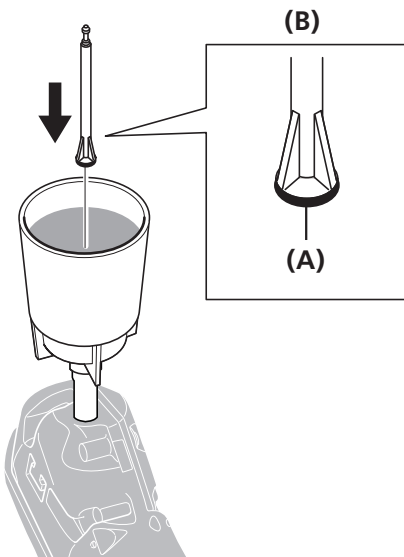

Plug the oil funnel with the oil stopper so that the O-ring mounted side is facing downward.

- (A) O-ring
- (B) Oil stopper

22

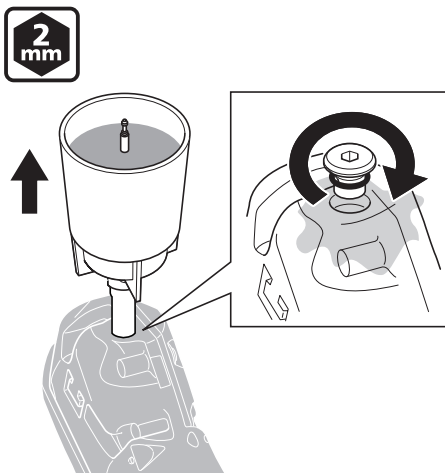

Remove the oil funnel and funnel adapter while still plugged with the oil stopper.

Attach the O-ring to the bleed screw and tighten it while letting oil flow out so as to make sure that no air bubbles remain inside the reservoir tank.

Tightening torque



0.5 - 0.7 N·m

NOTICE

Do not operate the brake lever. Otherwise, air bubbles may enter the cylinder.



TECH TIPS

Use a clean rag to prevent the oil from flowing to surrounding areas.

23

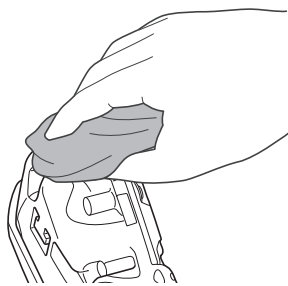

Wipe away any oil which has flowed out.

■ Installing the brake caliper

NOTICE

Use brake caliper fixing screws in the following combinations.

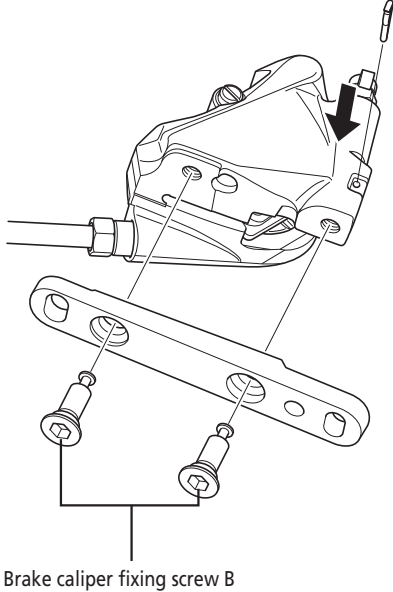
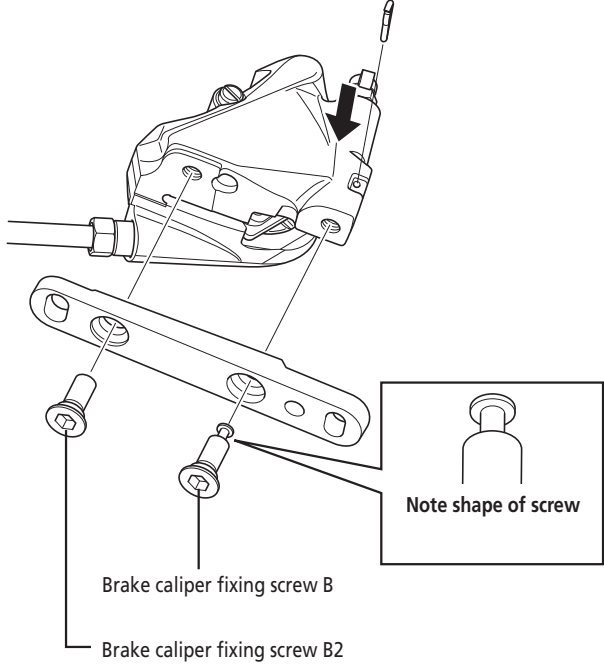
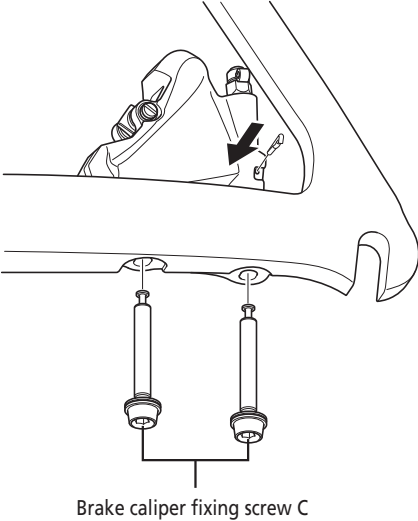
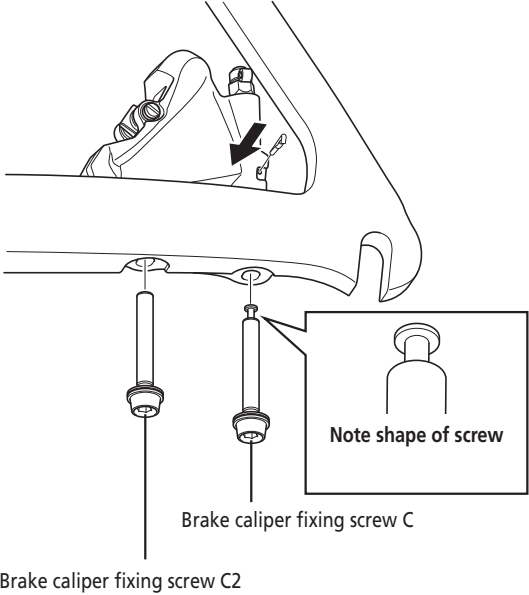
Front	
B + B	B + B2
 <p style="text-align: center;">Brake caliper fixing screw B</p>	 <p style="text-align: center;">Brake caliper fixing screw B</p> <p style="text-align: center;">Brake caliper fixing screw B2</p>
Rear	
C + C	C + C2
 <p style="text-align: center;">Brake caliper fixing screw C</p>	 <p style="text-align: center;">Brake caliper fixing screw C</p> <p style="text-align: center;">Brake caliper fixing screw C2</p>

INSTALLATION

▶ Installing the brake caliper

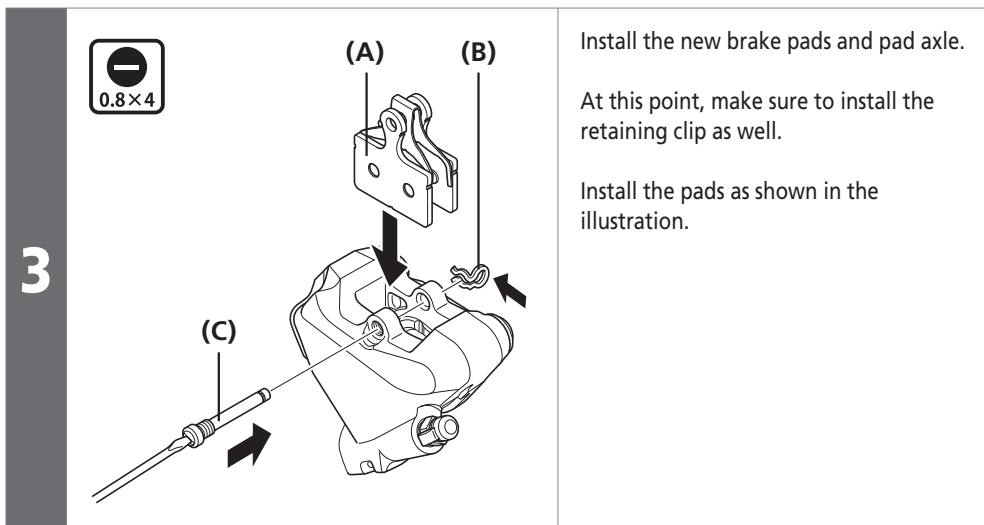
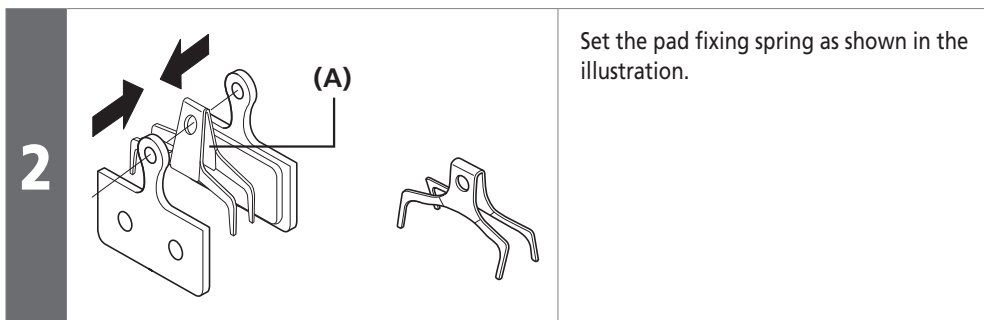
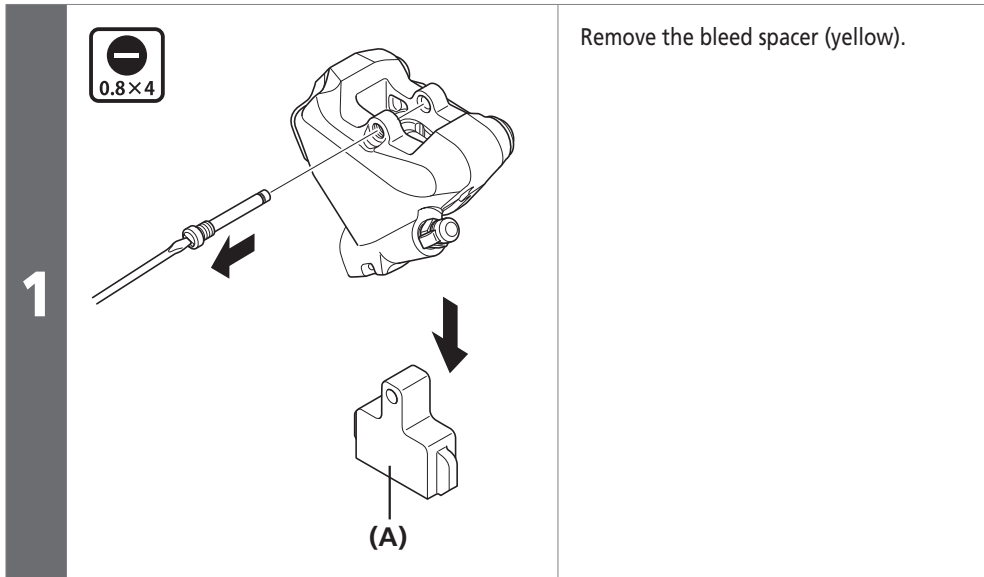

Check the length of brake caliper fixing screw C/C2

NOTICE

- A special mount bracket may be required depending on the frame and disc brake rotor combination.

Fork and frame mount type		Disc brake rotor size		
		140 mm (SS)	160 mm (S)	180 mm (M)
Flat mount Ø140/160	Rear	Mount bracket not required	SM-MA-R160 D/D	-
Flat mount Ø160/180	Rear	-	Mount bracket not required	SM-MA-R160 D/D

* BR-R9170 is not compatible with rear 180 mm (M) rotor.

**Same for 140 mm/160 mm/180 mm disc brake rotors
When using brake caliper fixing screws C+C**

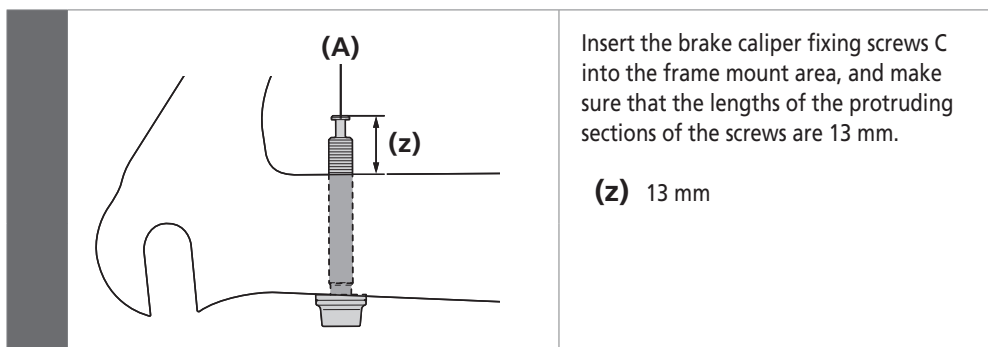

(A) Brake caliper fixing screw C

NOTICE

- When using a screw length selector (yellow), make sure the tip of the brake caliper fixing screw C is within the range A.

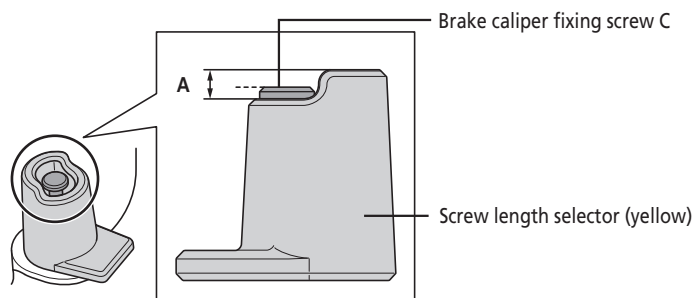

- Do not use a washer when checking the length of brake caliper fixing screw C.
- The length of the brake caliper fixing screw C used varies depending on thickness of the frame. Use brake caliper fixing screw C that is suitable for the thickness of the frame.

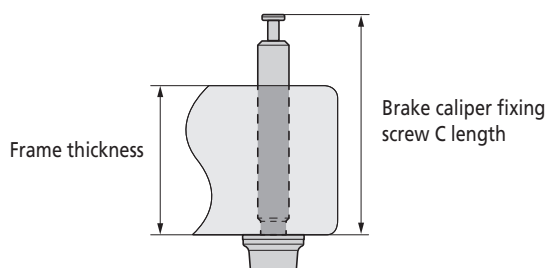

Frame thickness	Brake caliper fixing screw C length	Y-part
10 mm	23 mm	Y8N208000
15 mm	28 mm	Y8N208050
20 mm	33 mm	Y8PU08010
25 mm	38 mm	Y8PU08020
30 mm	43 mm	Y8PU08030
35 mm	48 mm	Y8N208040

When using brake caliper fixing screws C+C2

Insert the brake caliper fixing screws C/C2 into the frame mount area, and check that the length of the protruding section of the brake caliper fixing screws C/C2 is the specified length.

(y) 12 - 14 mm

(z) 8 - 9 mm

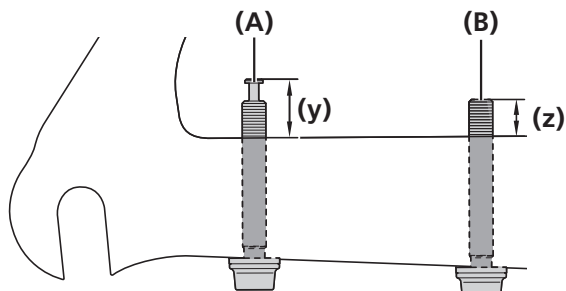

- (A)** Brake caliper fixing screw C
- (B)** Brake caliper fixing screw C2

NOTICE

- When using a screw length selector (white):
 - Ensure the tip of brake caliper fixing screw C is within the range of dimension A.
 - Ensure the tip of brake caliper fixing screw C2 is within the range of dimension B.

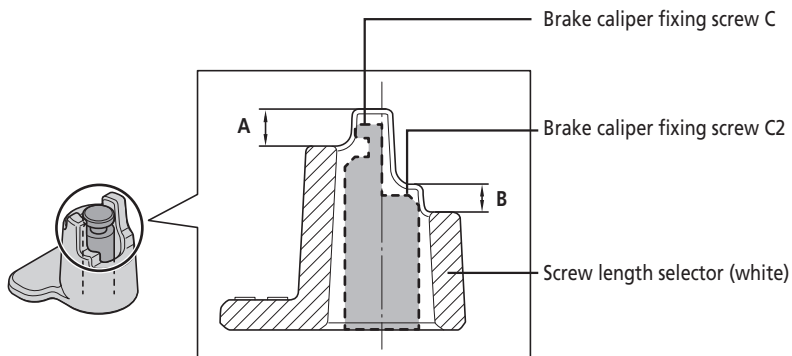

- Do not add any additional spacers to brake caliper fixing screws C/C2 when checking the length.
- The length of brake caliper fixing screws C/C2 to be used varies depending on the thickness of the frame. Use the brake caliper fixing screws C/C2 that are appropriate for the thickness of the frame.

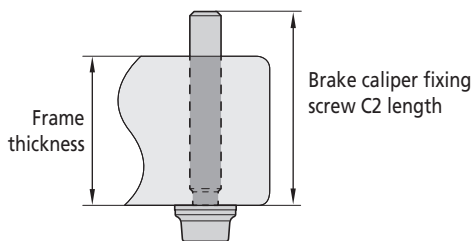
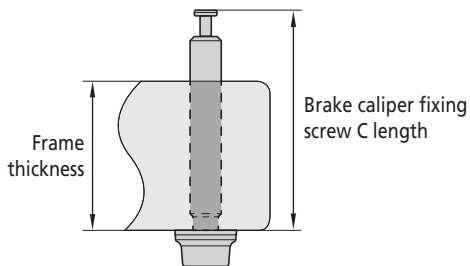

Frame thickness	Brake caliper fixing screw C length	Brake caliper fixing screw C2 length
10 mm	23 mm (Y8N208000)	19 mm (Y2J708000)
15 mm	28 mm (Y8N208050)	24 mm (Y2J708050)
20 mm	33 mm (Y8PU08010)	29 mm (Y2HW08010)
25 mm	38 mm (Y8PU08020)	34 mm (Y2HW08020)
30 mm	43 mm (Y8PU08030)	39 mm (Y2HW08030)
35 mm	48 mm (Y8N208040)	44 mm (Y2J708040)

When using a mount bracket
 (140 mm disc brake rotor)
 (160 mm disc brake rotors with Ø160/180 mount)

When using brake caliper fixing screws B+B

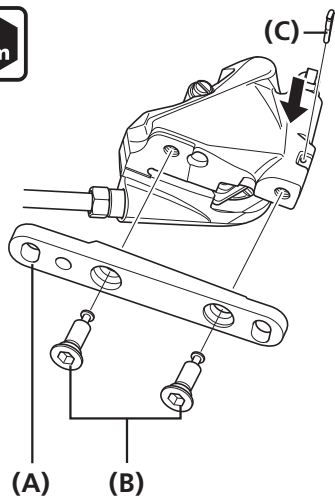

Attach the mount bracket to the brake caliper.

Install the screw fixing pin.
 Check that the screw fixing pin is fully inserted all the way to the back.

- (A) Mount bracket
- (B) Brake caliper fixing screw B
- (C) Screw fixing pin
- (D) Brake caliper fixing screw B2

Tightening torque



6 - 8 N·m

CAUTION

Correctly install brake caliper fixing screw B. There are two types of brake caliper fixing screws, and only brake caliper fixing screw B can be retained using a screw fixing pin. Failing to install correctly may cause the brake caliper fixing screws to fall out or lead to insufficient force for holding the brake caliper.

NOTICE

Observe the direction indicated on the mount bracket when installing it.

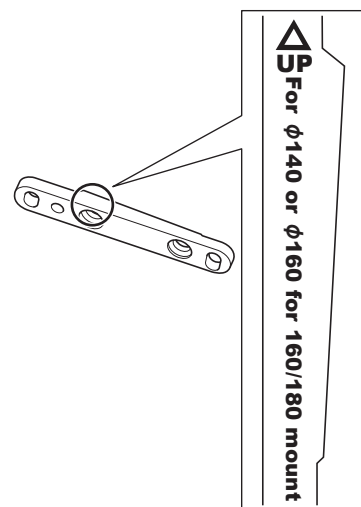

When using brake caliper fixing screws B+B2

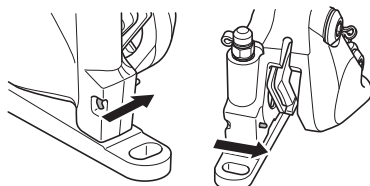
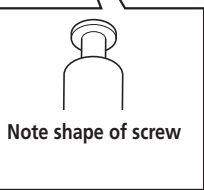
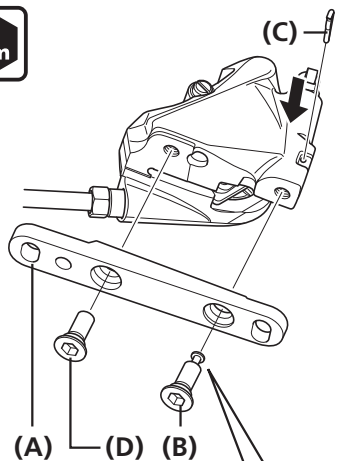

1

INSTALLATION

▶▶ Installing the brake caliper

Temporarily attach the mount bracket to the frame.

Depress the brake lever, and tighten the brake caliper fixing screws A while pressing the brake pads against the disc brake rotor.



2

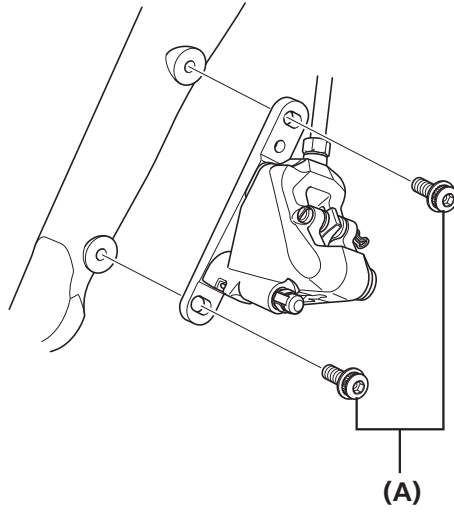

(A) Brake caliper fixing screw A

Tightening torque



6 - 8 N·m

3

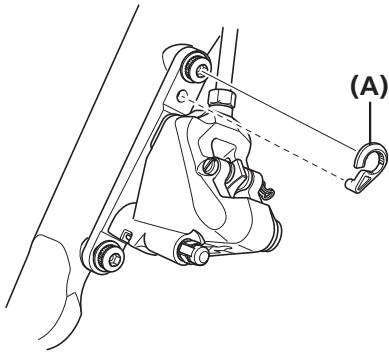

Install the snap ring.

Install the snap ring by inserting the protruding section of the snap ring into the mount bracket hole.

(A) Snap ring

When using a mount bracket
 (160 mm disc brake rotor)
 (180 mm disc brake rotors with Ø160/180 mount)

When using brake caliper fixing screws B+B

B+B

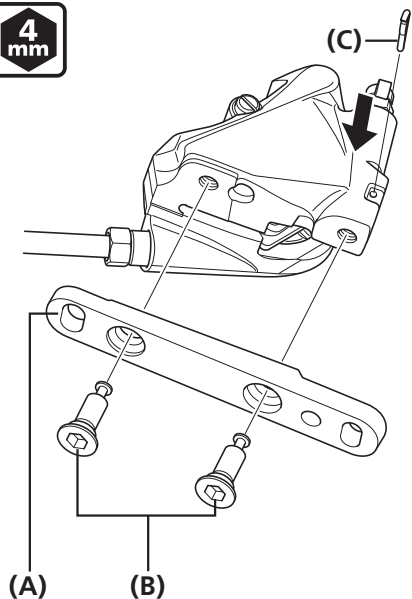

Attach the mount bracket to the brake caliper.

Install the screw fixing pin.
 Check that the screw fixing pin is fully inserted all the way to the back.

- (A) Mount bracket
- (B) Brake caliper fixing screw B
- (C) Screw fixing pin
- (D) Brake caliper fixing screw B2

Tightening torque



6 - 8 N·m

CAUTION

Correctly install brake caliper fixing screw B. There are two types of brake caliper fixing screws, and only brake caliper fixing screw B can be retained using a screw fixing pin. Failing to install correctly may cause the brake caliper fixing screws to fall out or lead to insufficient force for holding the brake caliper.

NOTICE

Observe the direction indicated on the mount bracket when installing it.

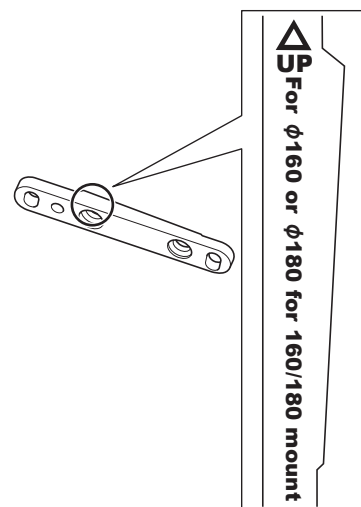

When using brake caliper fixing screws B+B2

B+B2

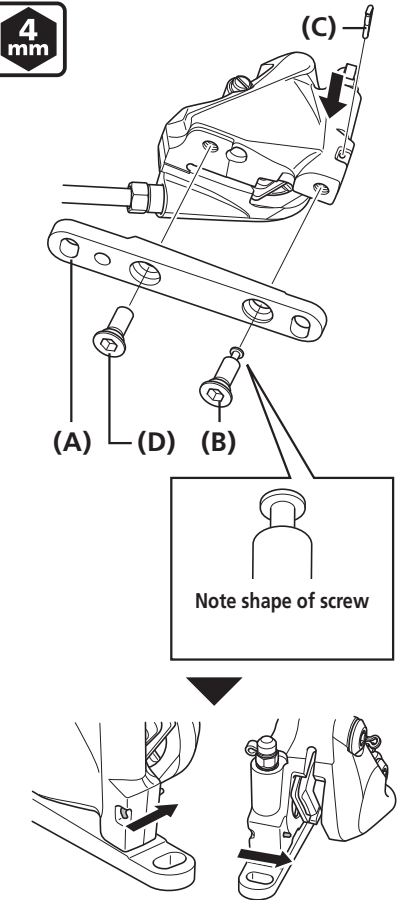

1

INSTALLATION

▶▶ Installing the brake caliper

Insert the brake caliper fixing screws A into the holes in the mount bracket first and then temporarily attach the mount bracket to the frame, as in the illustration.

Depress the brake lever, and tighten the brake caliper fixing screws A while pressing the brake pads against the disc brake rotor.

2

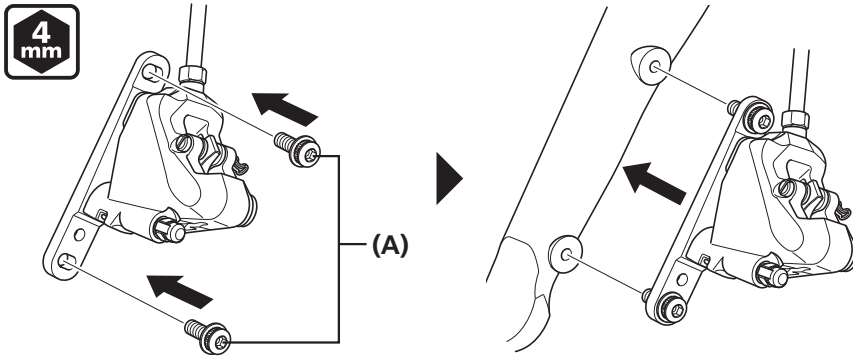

(A) Brake caliper fixing screw A

Tightening torque



6 - 8 N·m

NOTICE

Do not insert the brake caliper fixing screws A after placing the mount bracket on to the surface of the frame.

The brake caliper may be scratched by the fixing screws.

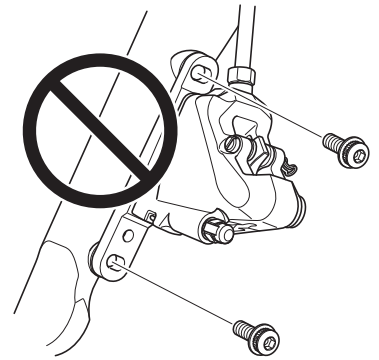

3

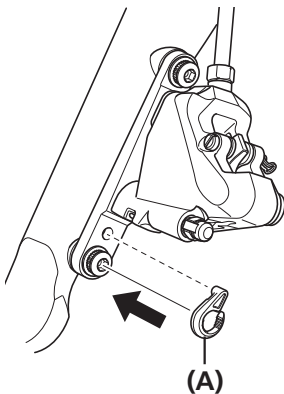

Install the snap ring.

Install the snap ring by inserting the protruding section of the snap ring into the mount bracket hole.

(A) Snap ring

▶▶ Installing the brake caliper

When using a brake caliper fixing screw C/C2
 (140 mm disc brake rotor)
 (160 mm disc brake rotors with Ø160/180 mount)

When using brake caliper fixing screws C+C

C+C

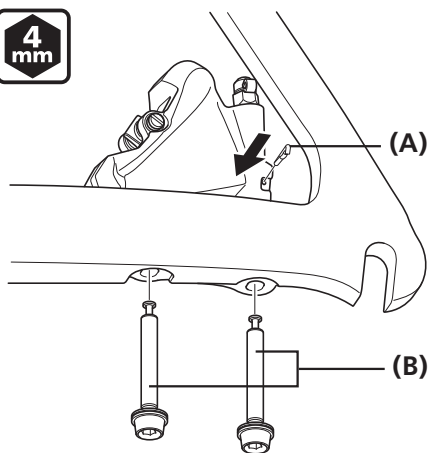

When using brake caliper fixing screws C+C2

C+C2

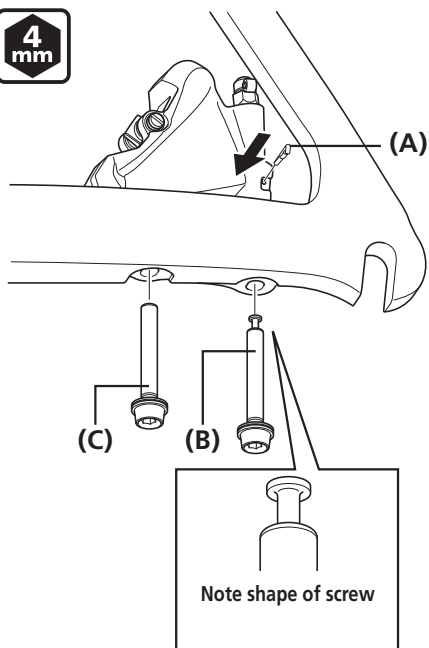

Attach the brake caliper to the frame.

Install the screw fixing pin.

- (A) Screw fixing pin
- (B) Brake caliper fixing screw C
- (C) Brake caliper fixing screw C2

Tightening torque	
	6 - 8 N·m

CAUTION

Correctly install brake caliper fixing screw C. There are two types of brake caliper fixing screws, and only brake caliper fixing screw C can be retained using a screw fixing pin. Failing to install correctly may cause the brake caliper fixing screws to fall out or lead to insufficient force for holding the brake caliper.

When using a brake caliper fixing screw C/C2
 (160 mm disc brake rotor)
 (180 mm disc brake rotors with Ø160/180 mount)

When using brake caliper fixing screws
 B+B

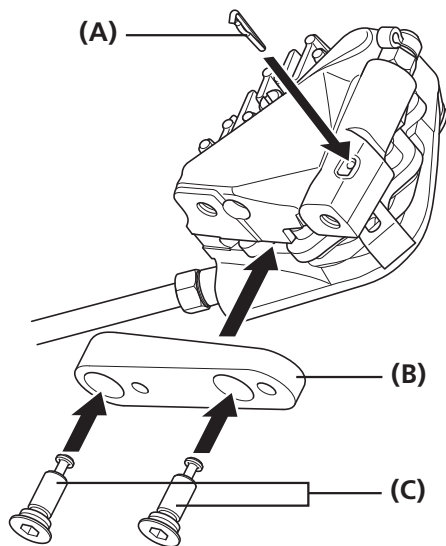

When using brake caliper fixing screws
 B+B2

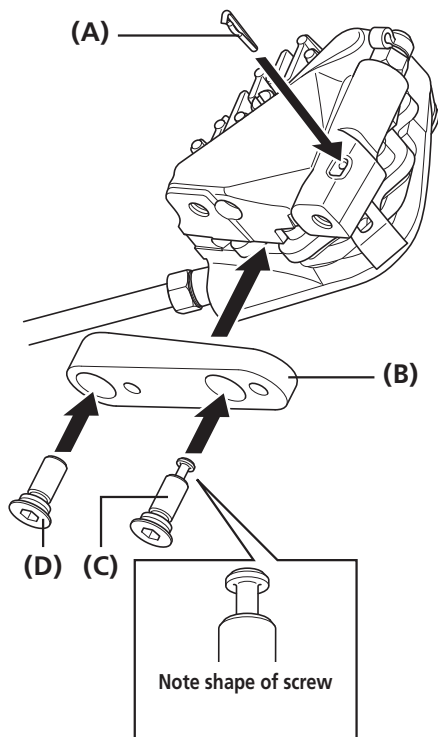

Attach the mount bracket to the brake caliper.

Install the screw fixing pin.

- (A) Screw fixing pin
- (B) Mount bracket
- (C) Brake caliper fixing screw B
- (D) Brake caliper fixing screw B2

Tightening torque



6 - 8 N·m

CAUTION

Correctly install brake caliper fixing screw B. There are two types of brake caliper fixing screws, and only brake caliper fixing screw B can be retained using a screw fixing pin. Failing to install correctly may cause the brake caliper fixing screws to fall out or lead to insufficient force for holding the brake caliper.

NOTICE

Observe the direction indicated on the mount bracket when installing it.

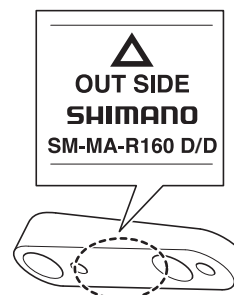

1

When using brake caliper fixing screws C+C

C+C

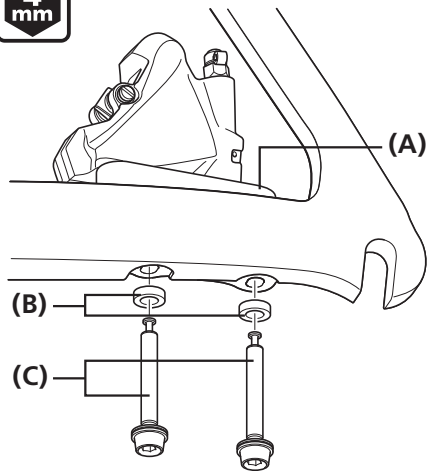

Use brake caliper fixing screws C/C2 and spacers to secure the mount bracket to the frame.

- (A) Mount bracket
- (B) Spacer
- (C) Brake caliper fixing screw C
- (D) Brake caliper fixing screw C2

Tightening torque



6 - 8 N·m

CAUTION

Correctly install brake caliper fixing screw C. There are two types of brake caliper fixing screws, and only brake caliper fixing screw C can be retained using a screw fixing pin. Failing to install correctly may cause the brake caliper fixing screws to fall out or lead to insufficient force for holding the brake caliper.

2

When using brake caliper fixing screws C+C2

C+C2

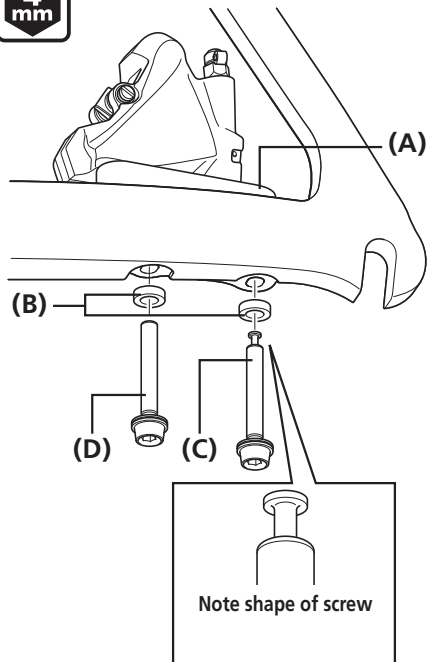

Install the retaining clip.

- (A) Retaining clip

3

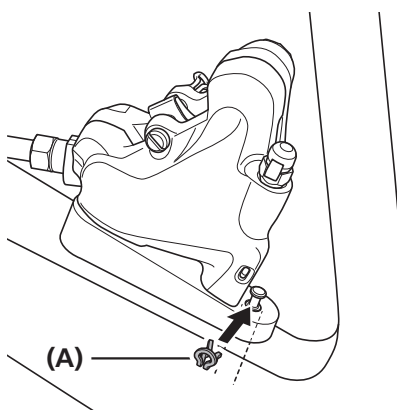

■ Temporary tightening of the frame fixing screws

Fixing pin insertion method

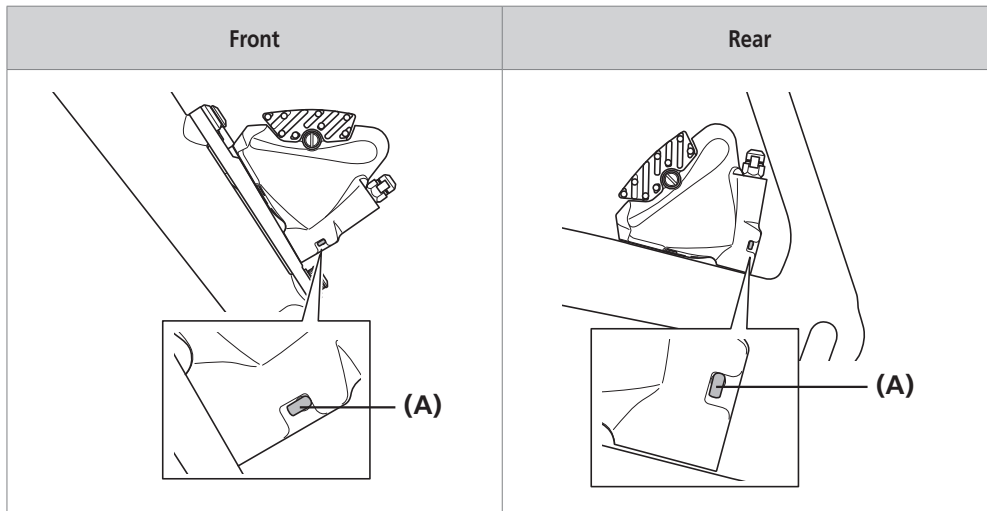

(A) Screw fixing pin

INSTALLATION

Installation of the shifting cable

Installation of the shifting cable

Cable to be used

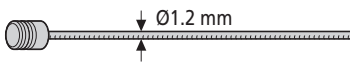
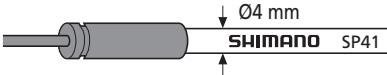
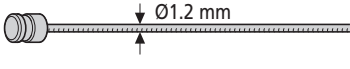
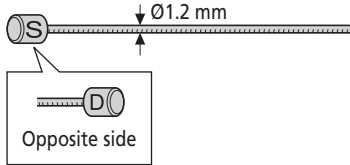
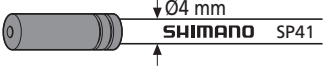
	Polymer coating inner cable	Recommended outer casing
R9100 series		Outer cap with tongue / SP41 outer casing 
R8000 series		
R7000 series / ST-4720 / ST-4725		Normal outer cap / SP41 outer casing 

NOTICE

Do not let dust adhere on the inner cable. If the grease on the inner cable is wiped off, the application of SIS SP41 grease (Y04180000) is recommended.

Outer cap with tongue installation position

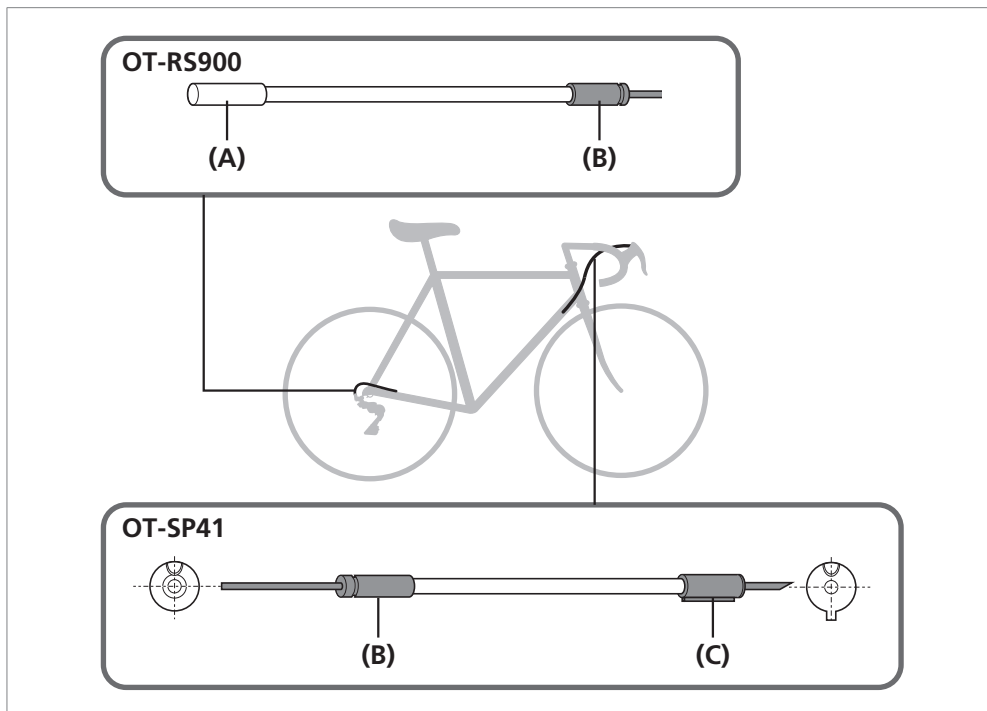

- (A) Sealed outer cap (aluminum type) (derailleur side)
- (B) Cap with long tongue
- (C) Cap with short tongue (shift lever side)

TECH TIPS

Be sure to insert the convex shape on the cap with short tongue into the groove in the bracket.

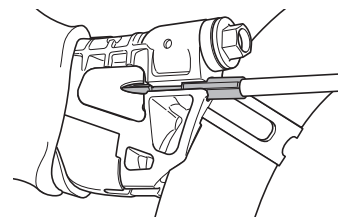

Cutting the outer casing

1

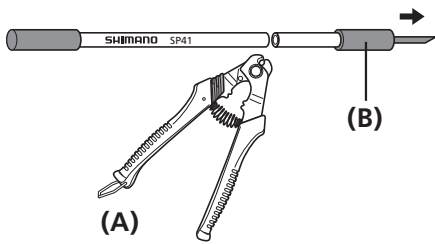

Use the cable cutter (TL-CT12) or an equivalent tool to cut the side opposite of the inscription.

- (A) TL-CT12
- (B) Outer cap with tongue

NOTICE

- Use a cable which still has some length to spare even when the handlebars are turned all the way to both sides.
- Be careful not to get your hand injured by the TL-CT12 needle section.

2

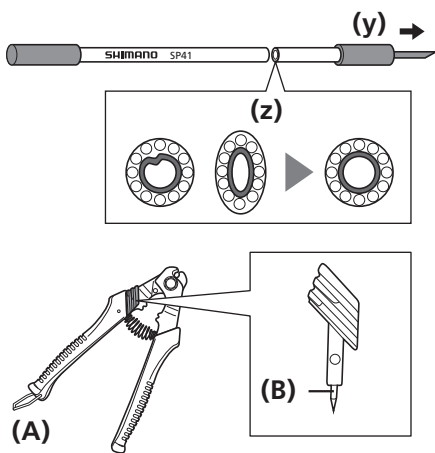

After cutting, expand the tip of the liner ($\varnothing 2.2$ or more) with TL-CT12 or other narrow tool.

- (y) Removing the outer cap with tongue
- (z) Arrange the cut end into a perfect circle

- (A) TL-CT12
- (B) TL-CT12 needle

3

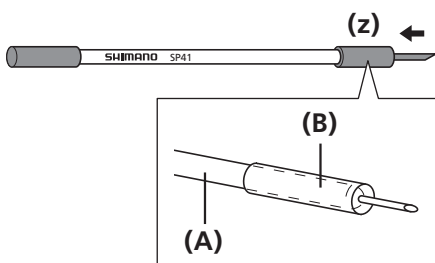

Insert the outer casing until it closely contacts with the end of the outer cap with tongue.

- (z) Install the outer cap with tongue

- (A) Outer casing
- (B) Outer cap with tongue

NOTICE

- Be careful not to crush the tip of the convex part of the outer cap with tongue when inserting the outer casing.

Passing through the shifting inner cable

The illustration shows the right hand lever.

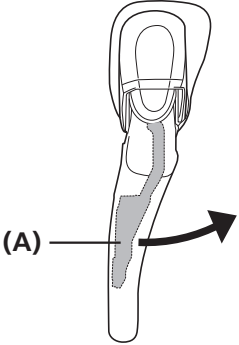
1		<p>Operate the release lever 10 or more times and set the lever to the top position.</p>
----------	---	--

(A) Release lever

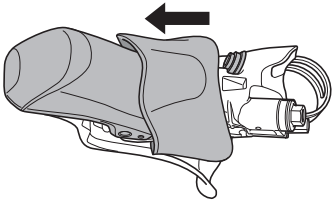
2		<p>Turn over the bracket cover from the back side.</p>
----------	---	--

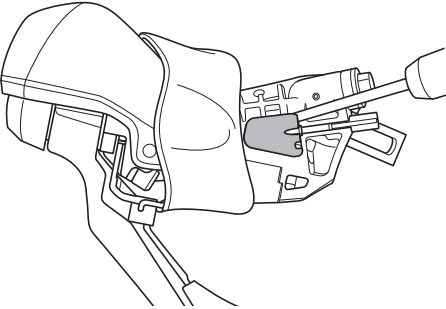
3		<p>Remove the cable cover from the bracket using a screwdriver.</p>
----------	---	---

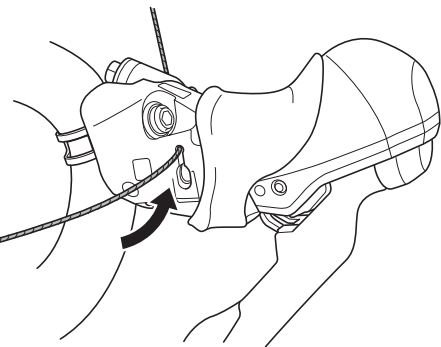
4		<p>Put the inner cable through as shown in the illustration.</p>
----------	---	--

NOTICE

Insert the cable while being careful not to allow coating on the inner cable to be damaged.

INSTALLATION

Installation of the shifting cable

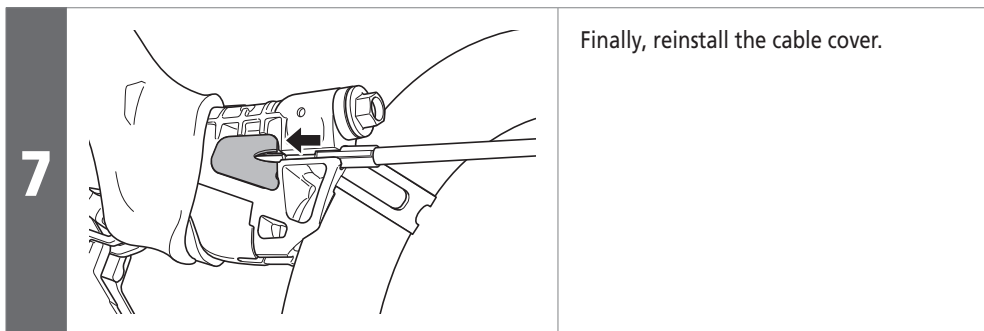
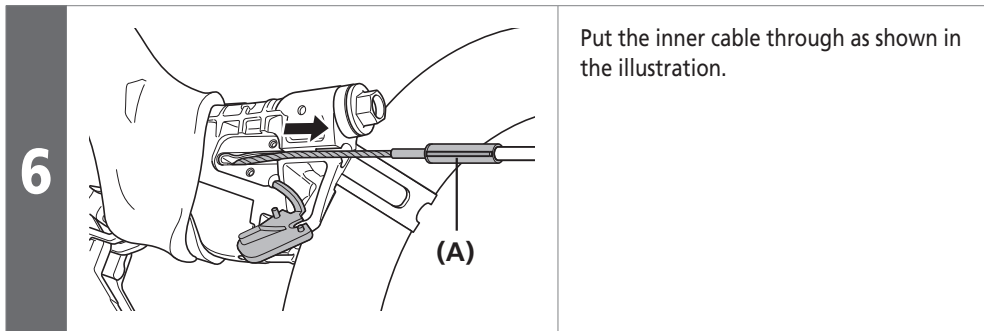
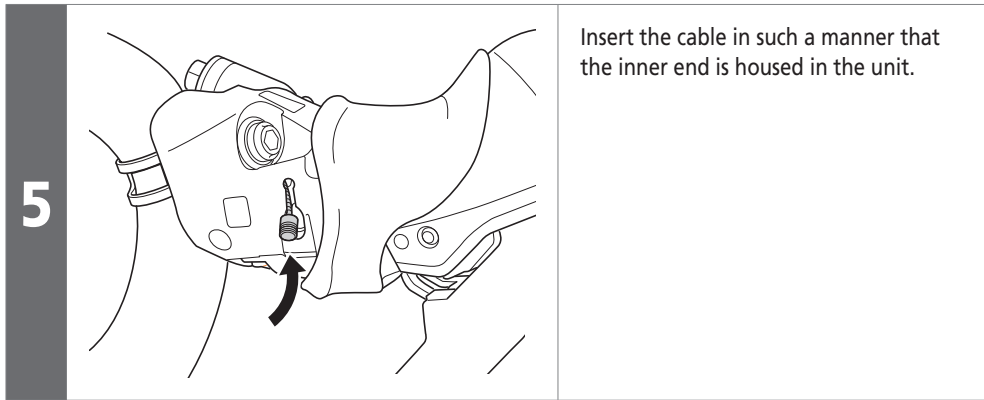

TECH TIPS

When the inner cable is installed, coating may be damaged and become fluffy; however, it will not affect the function.

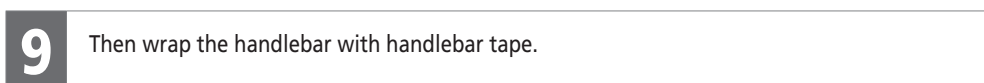
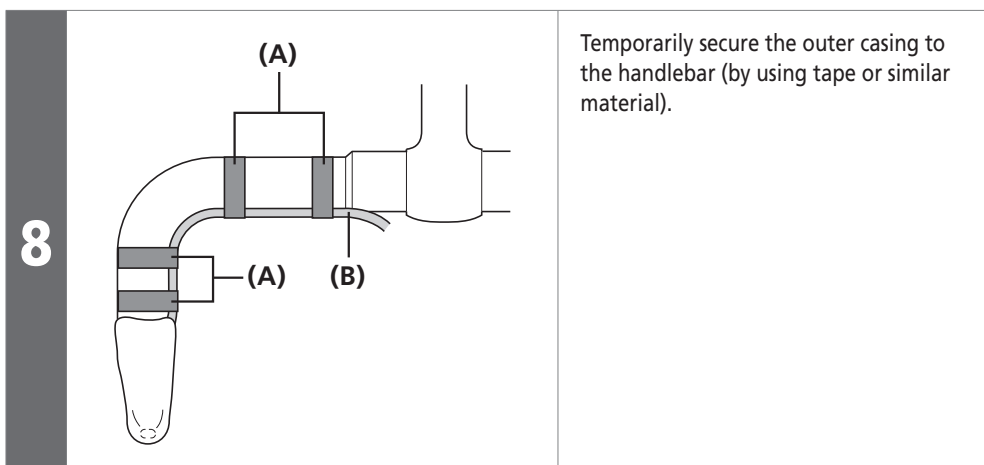

ADJUSTMENT

ADJUSTMENT

■ Free stroke and reach adjustment

1

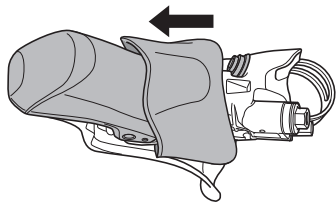

Turn over the bracket cover from the back side.



TECH TIPS

- Free stroke adjustment cannot be performed for ST-R7020 / ST-R7025 / ST-4720 / ST-4725
- When adjusting only the reach, perform step 3.

2

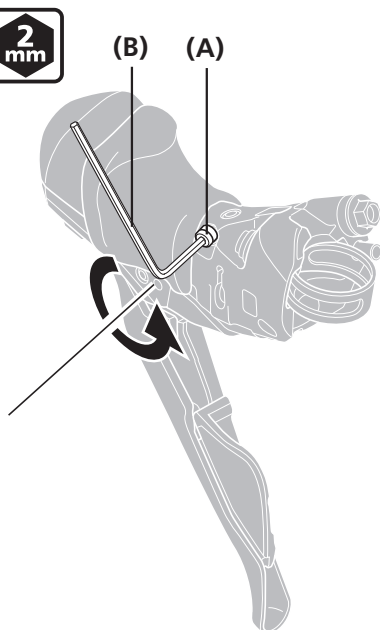

Turn the free stroke adjustment screw to adjust the stroke.

Turning in the direction shown in the illustration increases the free stroke.

- (A) Free stroke adjustment screw
- (B) 2 mm hexagon wrench

NOTICE

- Stop loosening the free stroke adjustment screw when the free stroke stops increasing. Loosening the free stroke adjustment screw excessively may cause the screw to be removed from the bracket unit. Do not forcibly tighten the free stroke adjustment screw. Otherwise, the adjustment screw may be damaged.
- Do not remove the washer from the free stroke adjustment screw.
- Position the free stroke adjustment screw so that it does not interfere with the bracket cover.

ADJUSTMENT

Free stroke and reach adjustment

ST-R9120 / ST-R8020 / ST-R8025

2 mm

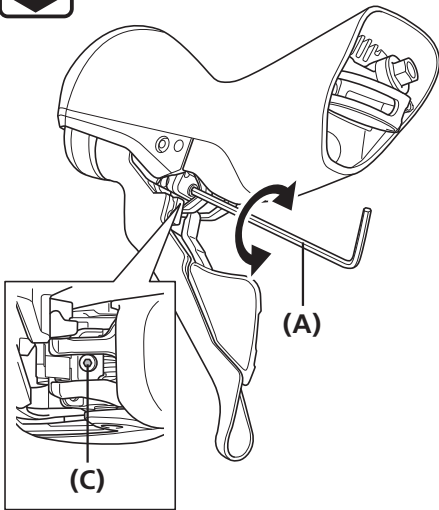

Turn the reach adjustment screw to position the lever unit.

- (A) 2 mm hexagon wrench
- (B) 2.5 mm hexagon wrench
- (C) Reach adjustment screw

NOTICE

Make sure that the braking operates after the adjustment.



TECH TIPS

ST-R9120 / ST-R8020 / ST-R8025

Clockwise: The grip width becomes wider
Counterclockwise: The grip width becomes narrower

ST-R7020 / ST-R7025 / ST-4720 / ST-4725

Clockwise: The grip width becomes narrower
Counterclockwise: The grip width becomes wider

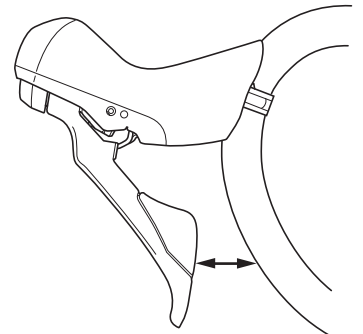

3

ST-R7020 / ST-R7025 / ST-4720 / ST-4725

2.5 mm

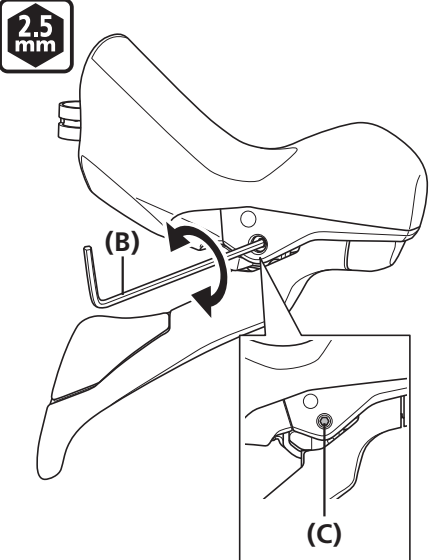

MAINTENANCE

MAINTENANCE

■ Replacing the brake pads

1

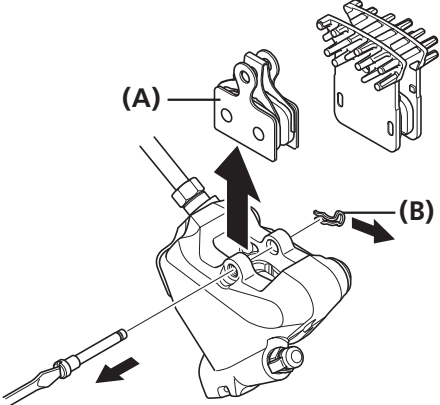

Remove the wheel from the frame, and remove the brake pads as shown in the illustration.

- (A) Brake pads
- (B) Retaining clip

NOTICE

- This brake system is designed to automatically adjust the clearance between the disc brake rotor and the brake pads by the piston gradually protruding according to the wear of the brake pads. When you replace the brake pads, you need to push back the piston.
- If oil adheres to the brake pads after oil is added, or if the brake pads are worn down to a thickness of 0.5 mm, or if the brake pad presser springs are interfering with the disc brake rotor, replace the brake pads.
- When using a pad with fins, take note of the left (L) and right (R) markings to set it.

2

Clean the pistons and surrounding area.

3

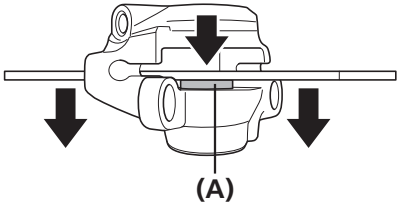

Use a flat-shaped tool to push the pistons straight back in as far as they will go, while being careful not to twist the pistons.

Do not push the pistons with a sharp tool.

The pistons may be damaged.

- (A) Piston

NOTICE

When pushing the pistons back, do so with the oil funnel attached to the dual control lever. Otherwise, the diaphragm of the dual control lever may be damaged by the oil pressure.

▶ Replacing the brake pads

4

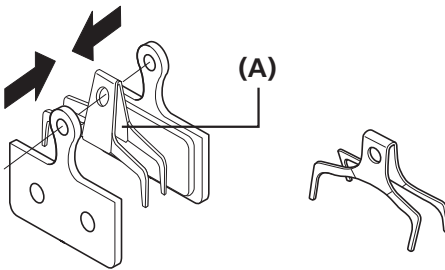

Install the pad fixing spring as shown in the illustration.

(A) Pad fixing spring

5

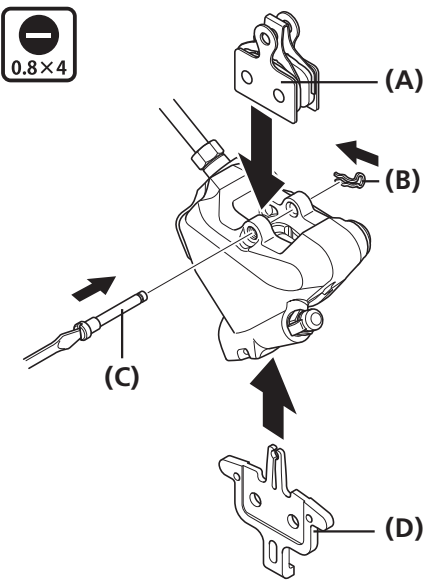

Install the new brake pads, the pad axle, and the pad spacer (red).
At this point, make sure to install the retaining clip as well.

(A) Brake pads
(B) Retaining clip
(C) Pad axle
(D) Pad spacer (red)

Tightening torque	
	0.2 - 0.4 N·m

6 Depress the brake lever several times to check that the operation becomes stiff.

7 Remove the pad spacer, install the wheel, and then check that there is no interference between the disc brake rotor and caliper.
If they are touching, adjust in accordance with section "Installing the brake caliper".

■ Replacement of the nameplate

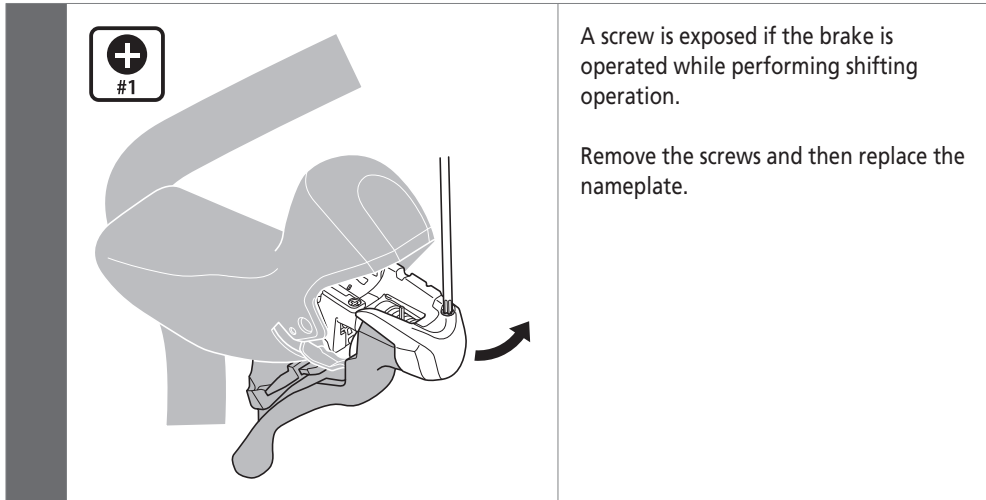

A screw is exposed if the brake is operated while performing shifting operation.

Remove the screws and then replace the nameplate.

Tightening torque	
	0.15 - 0.2 N·m

 **TECH TIPS**

As the screws are small, be careful not to drop them.

■ SHIMANO genuine mineral oil replacement

It is recommended to change your oil when the oil in the reservoir tank becomes noticeably discolored.

After attaching the bag and tube to the bleed nipple, open the bleed nipple and drain the oil. At this time, operate the dual control lever to make draining the oil easier. After draining the oil, refer to "Adding SHIMANO genuine mineral oil and bleeding air", then lubricate with oil from a newly opened container. Use only SHIMANO genuine mineral oil.

CAUTION

Note the following cautions when handling SHIMANO genuine mineral oil:

- Do not drink. May cause vomiting or diarrhea.
- Keep out of reach of children.
- Do not cut, let near heat, weld or pressurize the SHIMANO genuine mineral oil container. Doing so may cause an explosion or fire.
- Disposal of used oil: Follow local county and/or state codes for disposal. Use caution when preparing the oil for disposal.
- Directions: Keep the container sealed to prevent foreign objects and moisture from getting inside, and store it in a cool, dark area away from direct sunlight or heat. Keep from heat or flame
- For cleaning brake hoses exposed to mineral oil, or cleaning and maintaining tools, use isopropyl alcohol or a dry cloth. Do not use commercially available brake cleaners. Doing so may cause damage to plastic parts.

■ Replacing the bracket cover

Fit the tabs on the bracket cover into the slots on the bracket unit.

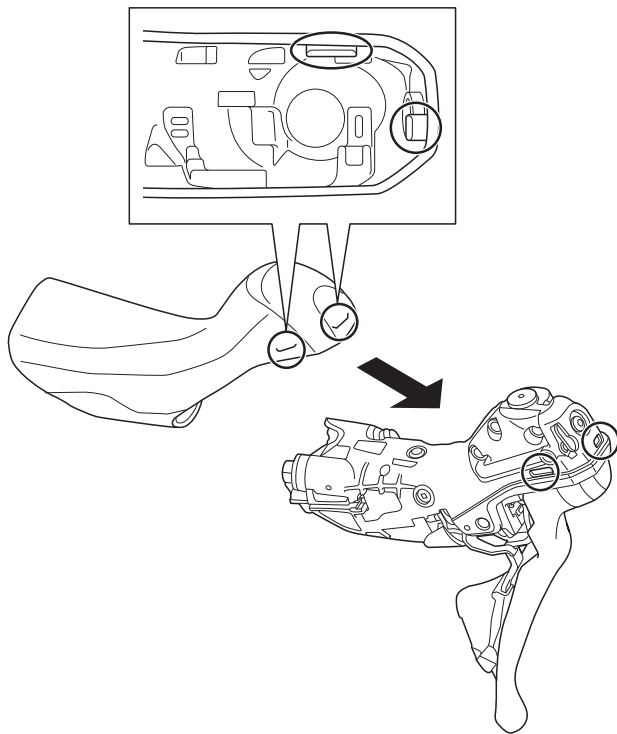

NOTICE

Note the markings

R: for right
L: for left

- The markings can be found on the inner surface of the bracket cover.
- Replace the bracket cover with the dual control lever and brake hose removed from the bicycle as shown in the illustration. Alternatively, remove the brake caliper from the frame and pass the bracket cover from the caliper side.
- Perform bleeding after removing the brake hose.



TECH TIPS

- Wipe a little rubbing alcohol inside the bracket cover to make fitting it easier.
- The tabs on the bracket cover each fit to a matching slot on the bracket.

■ Replacing the main lever support

1

Operate the release lever 2 or more times, and then shift the main lever by 2 gears.

(A) Release lever
(B) Main lever

2

Hold the base of the main lever with the hands and then return only the main lever to the original position.

(z) Hold with fingers.

(A) Main lever
(B) Main lever support

▶▶ Replacing the main lever support

3

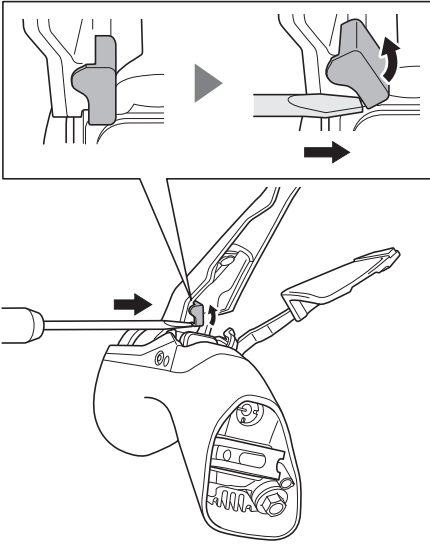

Rotate the main lever support in the direction of the arrow with a slotted screwdriver or an equivalent tool, and then remove the stopper.

4

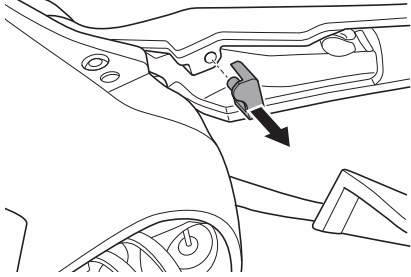

Pull out the main lever support.

5

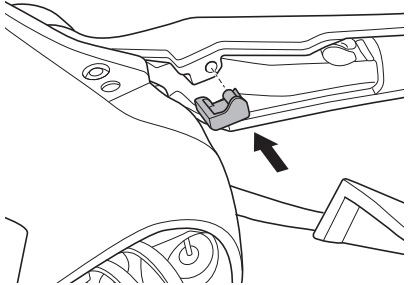

Insert a new main lever support.

■ Replacing the cable cover

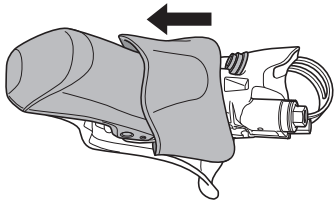
1		Turn over the bracket cover from the back side.
----------	---	---

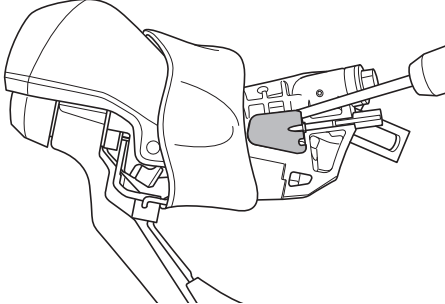
2		Remove the cable cover from the bracket using a screwdriver.
----------	---	--

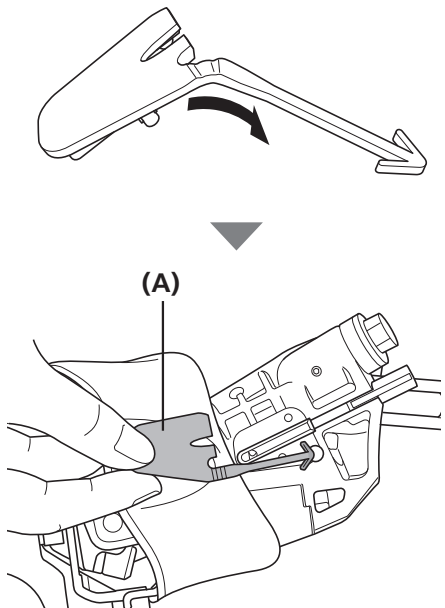
3		Before installing a new cable cover, make a slight crease on it and insert it into the hole in the bracket.
----------	--	---

(A) Cable cover

■ How to pull out a disconnected inner end (shifting cable)

If it is hard to pull out the inner end, follow the procedure below to pull out the inner end.

1 Remove the lever from the handle, and then remove the bracket cover.

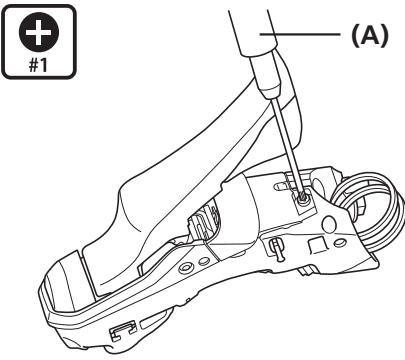
2  Remove the screw located at the bottom of the bracket, and then remove the unit cover.

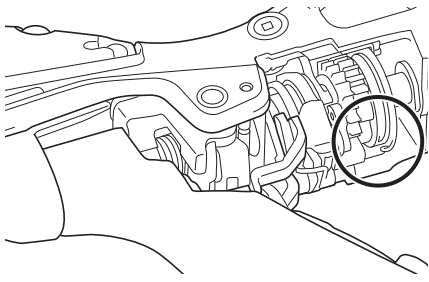
3  Pull out the inner end stayed on the cable hook of the winding body.

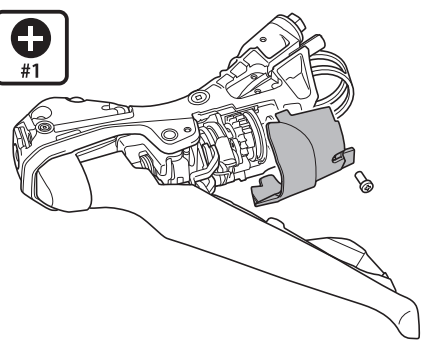
4  Reattach the unit cover and then tighten the screw.

 **TECH TIPS**

In order to maintain smooth shifting, it is recommended to also replace the cable guide when replacing a disconnected inner cable.

(A) Screwdriver [#1]

NOTICE

At this point, be careful not to touch the spring accidentally. Doing so could cause a functional trouble.

Tightening torque



0.2 - 0.25 N·m

■ Replacement of the SL cable guide

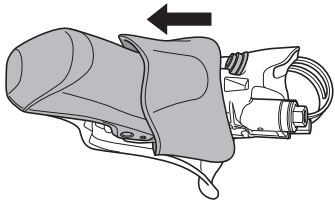
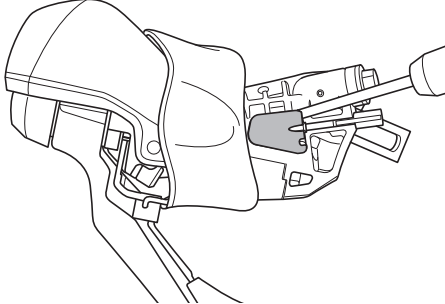
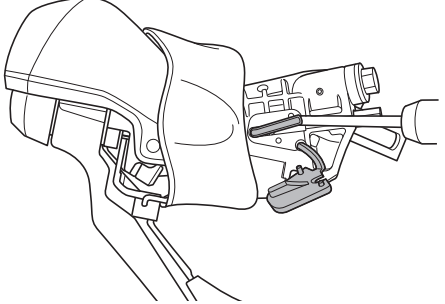
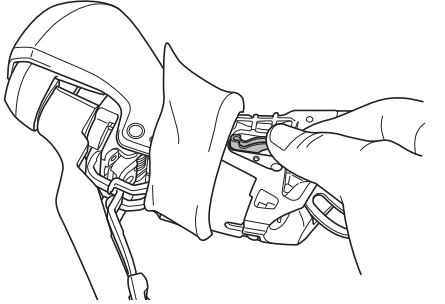
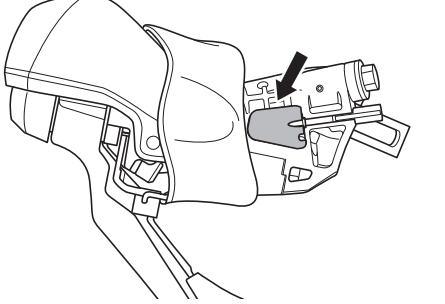
1		Turn over the bracket cover from the back side.
2		Remove the cable cover from the bracket using a screwdriver.
3		Use a pointed tool to pry out the SL cable guide.
4		Push in the new cable guide with hands.
5		Install the cable cover.

■ Replacing the diaphragm

1

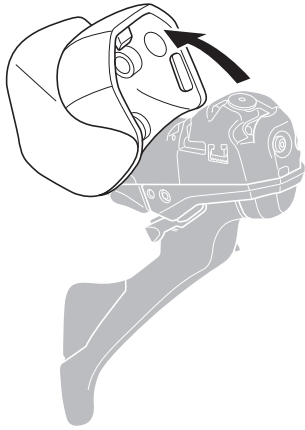

Turn over the cover from the front side.

2

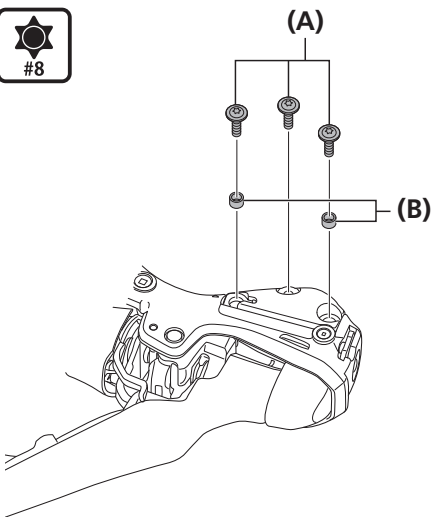

Remove the lid fixing screws and lid spacers.

(A) Lid fixing screw

(B) Lid spacer

NOTICE

- If the bracket has bosses, the lid spacers are not installed.

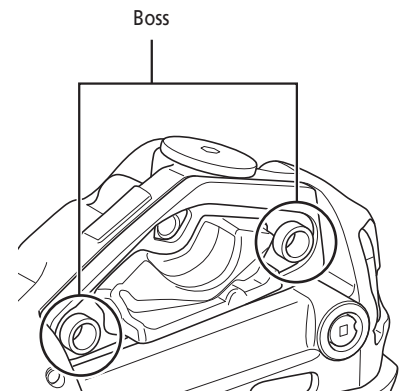

- Perform the replacement procedure with the lever facing the direction in which the lid fixing screws and lid, etc. can be removed straight up. Another direction will cause the oil to spill.

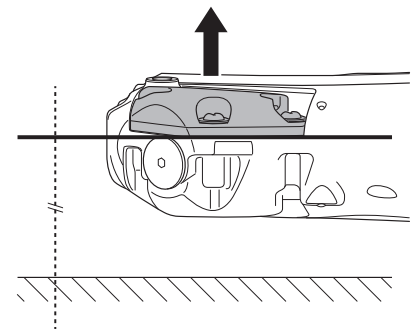

▶ Replacing the diaphragm

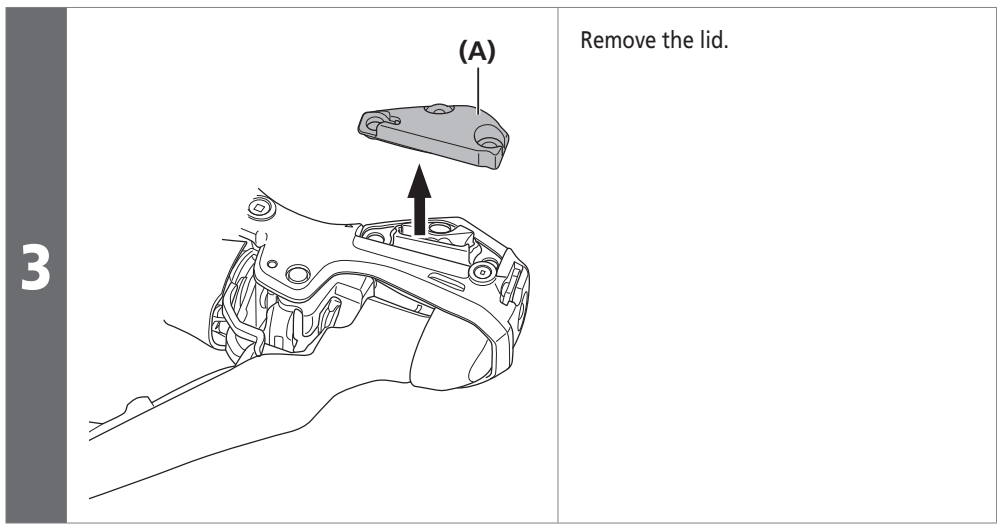

(A) Lid

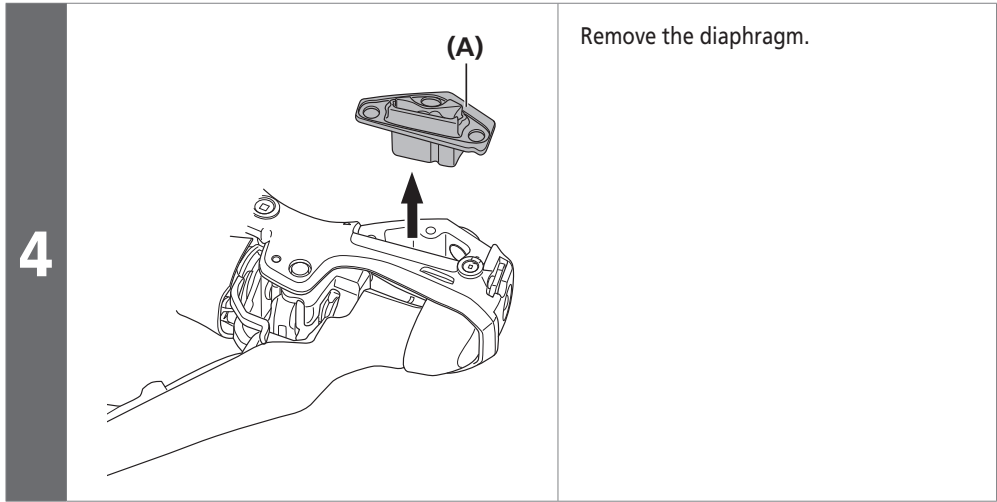

(A) Diaphragm

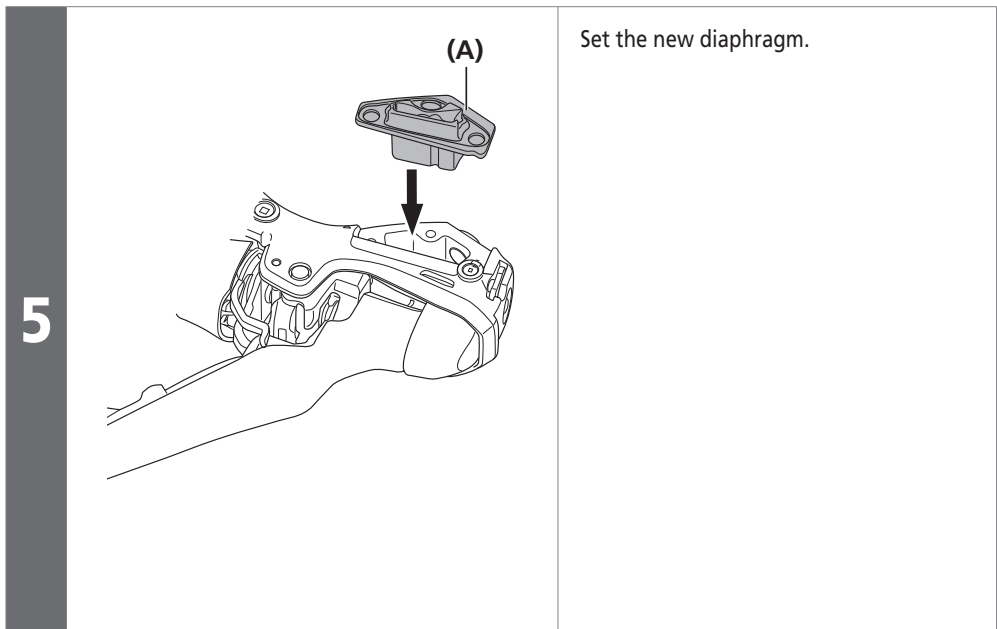

(A) Diaphragm

NOTICE

Note that the left and right diaphragms are different.



Left diaphragm



Right diaphragm

6

Bracket without bosses

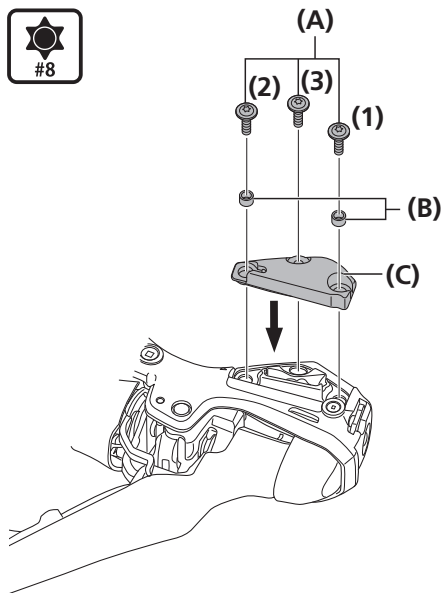

Bracket with bosses

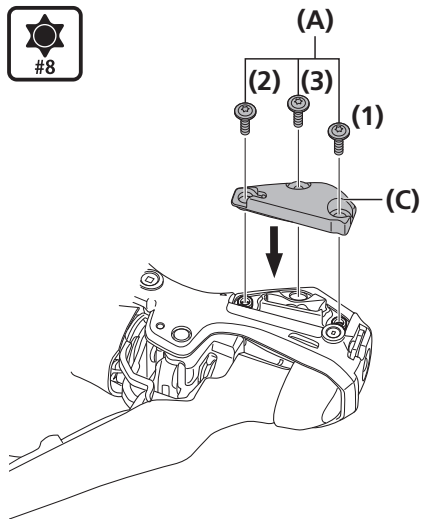

Install the lid.

Tighten the lid fixing screws in the order (1) to (3).

- (A) Lid fixing screw
- (B) Lid spacer
- (C) Lid

Tightening torque



0.8 N·m

NOTICE

- If the bracket has bosses, the lid spacers are not necessary.

Boss

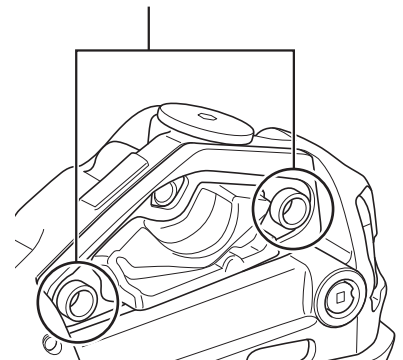

- If the bracket does not have bosses, ensure that the diaphragm is not caught between the lid spacer and bracket when tightening the lid fixing screws. The diaphragm may be torn.
- A lid spacer is not required for the lid fixing screw indicated by (3).
- After replacing the diaphragm, refer to "SHIMANO genuine mineral oil replacement" to inject the mineral oil and bleed the air from the system.

SHIMANO

SHIMANO NORTH AMERICA BICYCLE, INC.

One Holland, Irvine, California 92618, U.S.A. Phone: +1-949-951-5003

SHIMANO EUROPE B.V.

High Tech Campus 92, 5656 AG Eindhoven, The Netherlands Phone: +31-402-612222
Only EU General Contact : contactshimano@shimano-eu.com

SHIMANO INC.

3-77 Oimatsu-cho, Sakai-ku, Sakai City, Osaka 590-8577, Japan

Please note: specifications are subject to change for improvement without notice. (English)

© Apr. 2025 by SHIMANO INC. ITP