

Dealer's Manual

ROAD	MTB	Trekking
City Touring/ Comfort Bike	URBAN SPORT	E-BIKE

Dual Pivot Caliper Brake/Dual Control Lever (Di2)

DURA-ACE Non-Series

ST-R9250

BR-R9200

BR-R9210

BR-RS811-R

SW-RS801-E

SW-RS801-S

SW-RS801-T

ULTEGRA

ST-R8150

BR-R8100

BR-R8110

Contents

IMPORTANT NOTICE.....	3
TO ENSURE SAFETY.....	4
List of tools to be used	10
Installation/removal	11
Installing the dual control levers	11
Installing the brake cable	15
Installing the SM-CB90.....	20
Installing satellite shifters.....	22
Installing the brake calipers	33
Brake shoe setting position	39
Securing the BC-9000 cable	40
Adjustment.....	44
Arch spring tension adjustment.....	44
Readjustment of shoe clearance (when brake shoes are worn)	47
Adjusting the reach	48
Maintenance.....	50
Replacing the cartridge shoe	50
Brake shoe characteristics.....	52
Replacing the bracket cover.....	54



IMPORTANT NOTICE

- This dealer's manual is intended primarily for use by professional bicycle mechanics.
Users who are not professionally trained for bicycle assembly should not attempt to install the components themselves using the dealer's manuals.
If any part of the information on the manual is unclear to you, do not proceed with the installation. Instead, contact your place of purchase or a distributor for assistance.
- Make sure to read all manuals included with each product.
- Do not disassemble or modify the product other than as stated in the information contained in this dealer's manual.
- All manuals and technical documents are accessible online at <https://si.shimano.com> .
- For consumers who do not have easy access to the internet, please contact a SHIMANO distributor or any of the SHIMANO offices to obtain a hardcopy of the user's manual.
- Please observe the appropriate rules and regulations of the country, state or region in which you conduct your business as a dealer.

For safety, be sure to read this dealer's manual thoroughly before use, and follow it for correct use.

The following instructions must be observed at all times in order to prevent personal injury and physical damage to equipment and surroundings.

The instructions are classified according to the degree of danger or damage which may occur if the product is used incorrectly.

 DANGER	Failure to follow the instructions will result in death or serious injury.
 WARNING	Failure to follow the instructions could result in death or serious injury.
 CAUTION	Failure to follow the instructions could cause personal injury or physical damage to equipment and surroundings.

TO ENSURE SAFETY

WARNING

- Be sure to follow the instructions provided in the manuals when installing the product.
Only use SHIMANO genuine parts. If a component or replacement part is incorrectly assembled or adjusted, it can lead to component failure and cause the rider to lose control and crash.
-  Wear approved eye protection while performing maintenance tasks such as replacing components.

Be sure to also inform users of the following:

- Because each bicycle may handle slightly differently depending on the model, be sure to learn the proper braking technique (including brake lever pressure and bicycle control characteristics) and operation of your bicycle. Improper use of your bicycle's brake system may result in a loss of control, which could lead to serious injury due to a fall or collision.
- Do not apply the front brake too strongly. If you do so, the front wheel may lock and the bicycle may fall forward, and serious injury may result.
- Because the required braking distance will be longer during wet weather, reduce your speed and apply the brakes early and gently. You may fall or collide and be seriously injured.
- A wet road surface may cause tires to lose traction; therefore, to avoid this, reduce your speed and apply the brakes early and gently. If the tires lose traction, it may result in serious injury due to a fall or collision.
- Do not allow any oil or grease to get onto the brake shoes. Riding the bicycle with oil or grease on the brake shoes may prevent the brakes from operating and result in serious injury due to a fall or collision.
- Do not use the brake cable if it has any rust, fraying, or cracks. Otherwise, the brakes may not work correctly.

■ Dual control lever

- Do not throw or subject this product to strong shocks. If this is not observed, bursting, overheating or problems with operation may occur.
- When operating the shift switch, be careful not to allow your fingers to be caught in the derailleur. The motor in the derailleur is powerful enough to be operated without stopping until the shifting position is reached, and may cause serious injury if your fingers interfere with the shifting motion.

For installation to the bicycle and maintenance

- Use the brake and dual control levers or brake lever in the combinations specified in the following table. Do not use the combinations with the "NO" indication in the table. This will excessively increase the braking force, which could cause you to lose control of the bicycle, fall, and be seriously injured. (Refer to the dealer's manual for each model for details on the dual control levers and brake levers indicated in the table.)

TO ENSURE SAFETY

Caliper brake	Combinations	Dual control lever	Brake lever
BR-R9200 BR-R9210 BR-R8100 BR-R8110 BR-RS811-R	OK	ST-R9250 ST-R9100 ST-R9150 ST-R9160 ST-R8150 ST-R8050 ST-R8000 ST-R7000 ST-9070 ST-9071 ST-9001 ST-9000 ST-6870 ST-6871 ST-6800 ST-6770 ST-6700 ST-5800 ST-5700 ST-4700 ST-4600 ST-R3000 ST-3500 ST-2400 ST-R460 ST-R353 ST-R350	BL-4700 BL-4600 BL-R3000 BL-3500 BL-R2000 BL-R780 BL-2400 BL-TT79
	NO	Dual control levers not included above	Brake levers not included above

- The cable adjustment nut and quick release lever are not provided with the BR-RS811-R; be sure to use the SM-CB90 (cable adjuster). When the brake shoes are worn down, it becomes impossible to adjust the shoe clearance by hand. Also confirm that the SM-CB90 is in the "Close" position before riding the bicycle.
- Securely tighten the caliper brake fixing nuts to the specified tightening torque. If the nuts become loose and the brakes fall off, they may get caught up in the bicycle and the bicycle may fall over. In particular, if this happens with the front wheel, you may be thrown forward and seriously injured.
- Use lock nuts with nylon inserts (self-locking nuts) for nut-type brakes.
- For sunken nut-type brakes, use sunken nuts of the appropriate length which can be threaded onto the fixing screw for at least five full turns. When re-assembling, apply a threadlocker to the nut threads.
- Brakes designed for use as rear brakes should not be used as front brakes. Also, brakes designed for use as front brakes should not be used as rear brakes.
- Make sure to use the dedicated brake shoe for the shoe holder of the BR-R9210-F / R8110-F / RS811-R. The conventional brake shoes have different fixing positions preventing the fixing screw from being tightened,

TO ENSURE SAFETY

which will cause the brake shoe to come off and disable braking.

Dedicated brake shoes:

R55C4 / R55C4 (for carbon rim) / R55C4-A (for carbon rim) / R55CT4

- Do not install the shoe and shoe holder on the wrong side. There are two different types of shoe and shoe holder for the left and right respectively. Take note of the correct directions and screw hole positions for inserting the shoes.

■ BR-R9210-RS / BR-R8110-RS

- BR-R9210-RS / BR-R8110-RS is designed for use as a rear brake and should not be used as a front brake. BR-R9210-F / BR-R8110-F (front brake) and BR-R9210-RS / BR-R8110-RS use different shoe holders and internal parts.

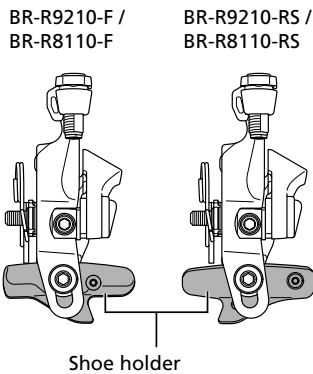

■ BC-9000

BC-9000 (polymer coating brake cable) has low frictional resistance; therefore, be sure to observe the following instructions. If not observed, the holding force of the brake cable will not be sufficient causing the brake cable to slacken, a loss of brake control and possibly severe injury.

- Make sure to use it in combination with a brake in the BR-R9210 / BR-R8110 / BR-RS811-R series.
- Use the designated Cable Grease (Y04180000) for BC-9000.
- When the inner cable is passed through the outer casing, be sure to wipe the inner cable fixing section with a cloth before fixing the inner cable. Grease may adhere to the inner cable fixing section and prevent sufficient holding force.

NOTICE

Be sure to also inform users of the following:

- In the case of carbon levers, wash them with a soft cloth using a neutral detergent. Otherwise, the material may be damaged and lose strength.
- Avoid leaving the carbon levers in areas of high temperature. Also keep them well away from fire.
- When combined with a ceramic rim, SHIMANO road brake shoes wear down more quickly.
- If the brake shoes have worn down until the grooves are no longer visible, consult your place of purchase or a distributor.
- Different brake shoes have their own characteristics. Ask the place of purchase or a distributor for details when purchasing the brake shoes.
- Be sure to keep rotating the crank arm during gear shifting operations.
- Be careful not to get water into the E-TUBE ports and the satellite shifter connection port.
- The components are designed to be fully waterproofed to withstand wet weather riding conditions; however, do not deliberately place them into water.
- Do not clean the bicycle in a high-pressure wash. If water gets into any of the components, operating problems or rusting may result.
- Contact the place of purchase for updates of the component software. The most up-to-date information is available on the SHIMANO website.
- Be sure to attach dummy plugs to any unused E-TUBE ports and the satellite shifter connection port. If water gets into any of the components, operating problems or rusting may result.
- The electric wire has small waterproof connectors, so do not repeatedly connect and disconnect it too often. Doing so may impair the waterproofing.
- Products are not guaranteed against natural wear and deterioration from normal use and aging.
- For maximum performance we highly recommend SHIMANO lubricants and maintenance products.

For installation to the bicycle and maintenance

- Use an outer casing/electric wire which still has some length to spare even when the handlebars are turned all the way to either side. Furthermore, check that the dual control levers do not touch the bicycle frame when the handlebars are turned all the way.
- Use the parts indicated in the exploded view of the dual control levers when you replace the clamp band, clamp screw, or clamp nut.
- Even with the recommended tightening torque, there is a possibility that the carbon handlebars may become damaged and insufficiently tightened. Confirm the appropriate torque value with the bicycle manufacturer or the handlebar manufacturer.

TO ENSURE SAFETY

■ Dual control lever

- Dummy plugs are installed at the time of shipment from the factory. Do not remove them except when necessary.
- When routing the electric wires, take care to ensure that they do not interfere with the brake levers.





■ Satellite shifter

- When connecting electric wires, make sure that foreign matter does not get inside the plug or satellite shifter connection port. A connection with foreign matter present may result in a malfunction.
- If the plug is exposed during storage, transportation, or maintenance work, and there is a possibility of foreign matter getting inside, protect the plug with masking tape or a similar material.
- If you do not feel a click when connecting an electric wire, check that there is no foreign matter inside the plug or satellite shifter connection port. If foreign matter is present, use a blower to remove it. If the problem persists, replace the satellite shifter with a new one.

The actual product may differ from the illustration because this manual is intended mainly to explain the procedures for using the product.

List of tools to be used

The following tools are needed for installation, adjustment, and maintenance purposes.

Tool	
	2 mm hexagon wrench
	4 mm hexagon wrench
	5 mm hexagon wrench
	Slotted screwdriver Blade width at tip: 4.0 - 5.0 mm Blade thickness at tip: 0.5 - 0.6 mm
	TL-CT12
	TL-EW300
	Utility knife
	Cutters

Installation/removal

Installing the dual control levers

1. Turn over the bracket cover from the front side.

Gently turn over the ends of the bracket cover with both hands and slowly push them down.

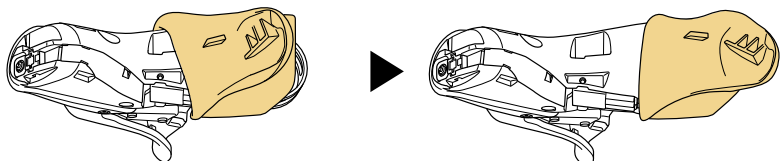

NOTICE

- Forcibly pulling the bracket cover may damage it because of its material properties.

2. Loosen the clamp screw and pass the clamp band over the handlebar.

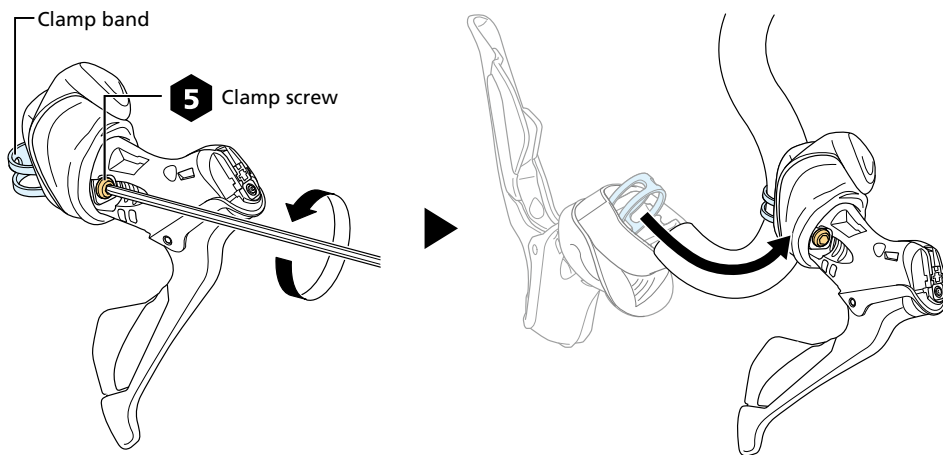

3. Temporarily install the lever to the handlebar.

Temporarily install the lever so that it cannot move.

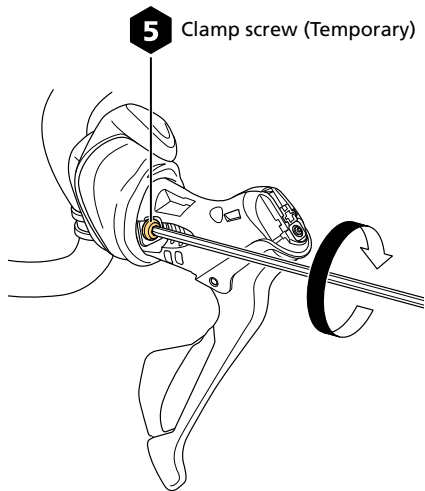

NOTICE

- Use the parts indicated in the exploded view of the dual control levers when you replace the clamp band, clamp screw, or clamp nut.

4. Return the turned bracket cover to its original position and turn it over from the back side.

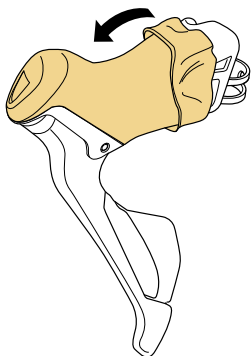

5. Lift up the port junction.

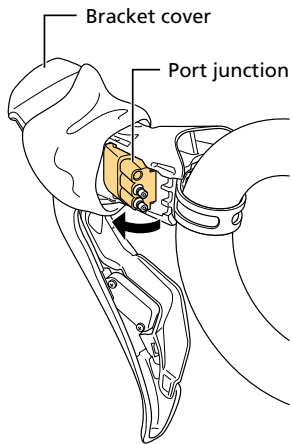

NOTICE

- When removing/inserting dummy plugs or electric wires, be sure the port junction is firmly supported by hand or by the bracket body. Otherwise you may cause damage to the inner connecting wires of the dual control levers.

6. Connect the electric wire. If required, first remove the dummy plug of the E-TUBE port.

Be sure to push it in firmly with the TL-EW300 until you feel a click.

For instructions on using the TL-EW300, refer to the ROAD Di2 Series General Guide .

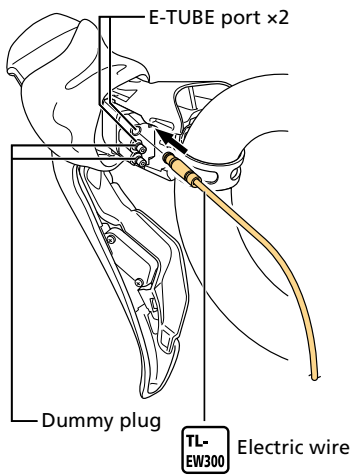

NOTICE

- It is possible for the electric wires to become disconnected accidentally while riding or winding the handlebar tape. By allowing sufficient wire length, accidental disconnection can be prevented after winding the handlebar tape.
- Ensure that the electric wire to connect to the dual control levers has extra length to make it easier to remove and insert when performing maintenance.

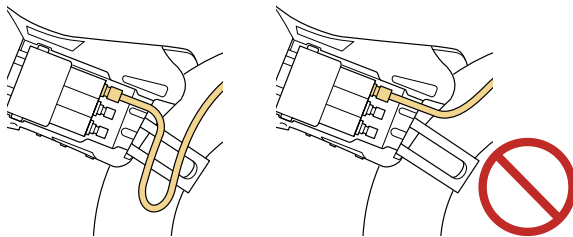

TECH TIPS

- PC linkage devices can be connected to the E-TUBE port when performing maintenance. However, leave the dummy plug attached to the unused E-TUBE port when a PC linkage device is not in use.

7. After installing and connecting brake hose and electric wire, check the connections.

8. Secure the dual control levers to the handlebar.

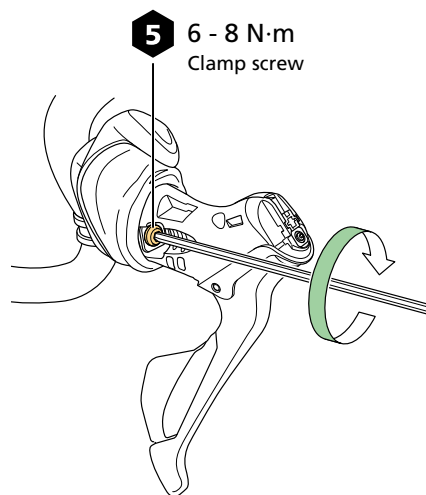

Installing the brake cable

Outer casing comes internally pre-lubricated with an appropriate grease.

⚠ WARNING

- When an inner cable is passed through the outer casing, be sure to wipe the fixing section of the inner cable which will be secured by the clamp screw before securing the cable. Residual grease in the area of the clamp screw may prevent sufficient holding force.

NOTICE

- When feeding the BC-9000 inner cable through the shift lever or caliper brake, try to minimize the contact between the cable and the components. If the coating of the cable gets abraded during installation, it may develop a fuzzy appearance, although this will not affect performance.

Cable to be used

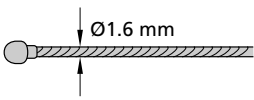
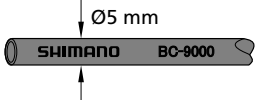
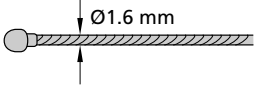
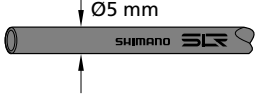
BC-9000 inner cable	BC-9000 outer casing
	
BC-1051 inner cable	SLR outer casing
	

Cutting the outer casing

1. Cut the outer casing using a cable cutter (TL-CT12).

Cut the outer casing so that the coil does not tip over inward.

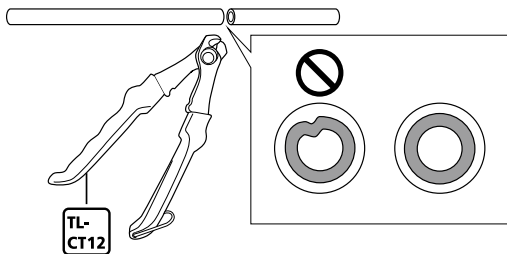

NOTICE

- Cut the outer casing so it still has some length to spare even when the handlebars are turned all the way to either side.

2. Spread out the tip of the liner using a thin tool such as a TL-CT12 needle.

Arrange the cut end into a perfect circle.

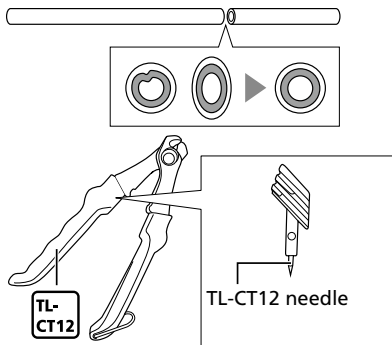

⚠ CAUTION

- Be careful not to hurt your hands with the TL-CT12 needle.

Installation/removal

Installing the brake cable

3. Install the outer cap with tongue.

Insert the outer casing until it closely contacts with the seating surface of the outer cap with tongue.

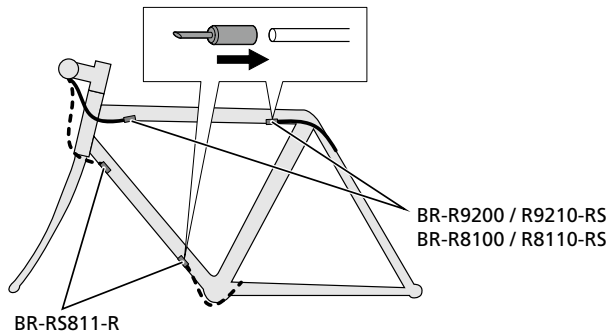

NOTICE

- When inserting the outer casing, take care to ensure that the tip of the outer cap with tongue is not damaged.
- When using the BC-1051 inner cable, use a regular outer cap rather than an outer cap with tongue.

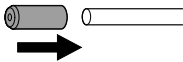

Installing the brake cable

1. Depress the brake lever and insert the brake cable.

Pass the brake cable through the outer casing and install it to the lever as shown in the figure.

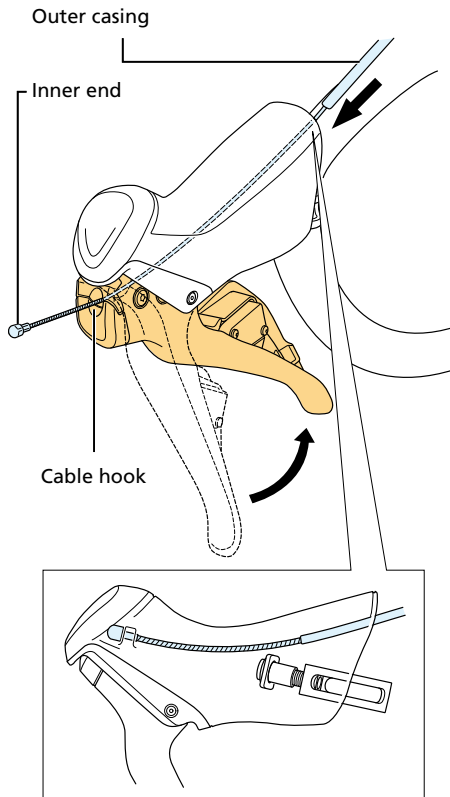

NOTICE

- Make sure that the inner end is firmly fit into the cable hook.

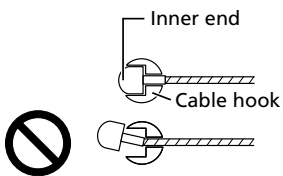

2. Temporarily secure the outer casing to the handlebar (by using tape or a similar material).

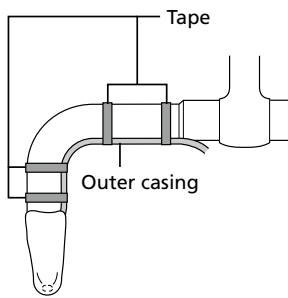

Installing the SM-CB90

⚠ WARNING

- The cable adjustment nut and quick release lever are not provided with the BR-RS811-R; be sure to use the SM-CB90 (cable adjuster). When the brake shoes are worn down, it becomes impossible to adjust the shoe clearance by hand. Also confirm that the SM-CB90 is in the "Close" position before riding the bicycle.

NOTICE

- Be sure to install the SM-CB90 so that it does not contact the frame when the handlebars are turned.

Installation

1. Install the SM-CB90.

- (1) Pass the inner cable through the SM-CB90 and install it to the outer casing on the brake lever side.
- (2) Move the quick release lever to the "Open" position.
- (3) Install the outer casing on the brake caliper side to the SM-CB90.
- (4) Move the quick release lever to the "Close" position.

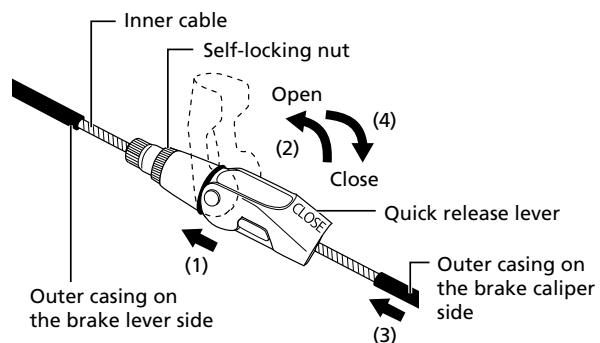

NOTICE

- Ensure the orientation of the SM-CB90 is the same as is illustrated in the figure.

Installing satellite shifters

This section describes how to add a satellite shifter.

SW-RS801-T

Routing map

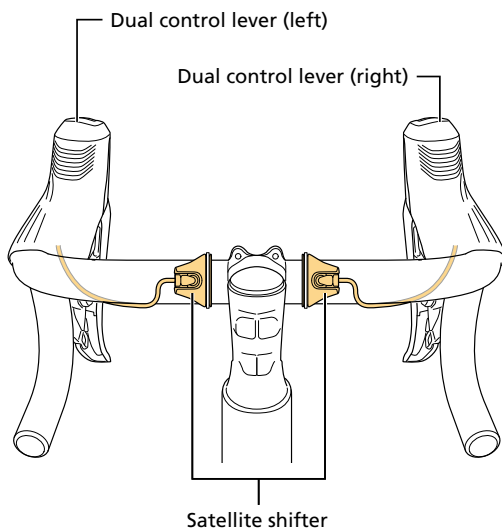

Connection method

1. Set the band on the shift unit.

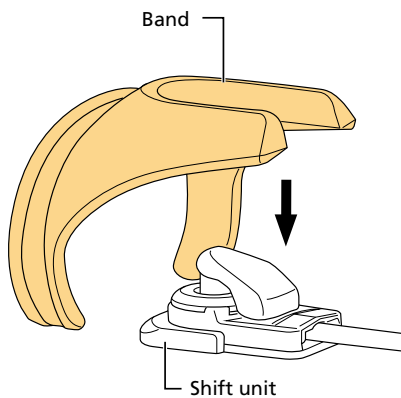

Installation/removal

Installing satellite shifters

2. Place the rubber sheet on the installation position and set the satellite shifter on top of it.

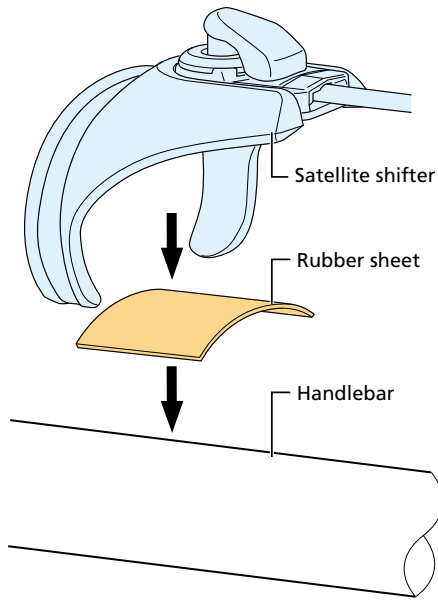

3. Secure the satellite shifter to the handlebar with a zip tie.
Wind the zip tie aligned with the groove on the band.

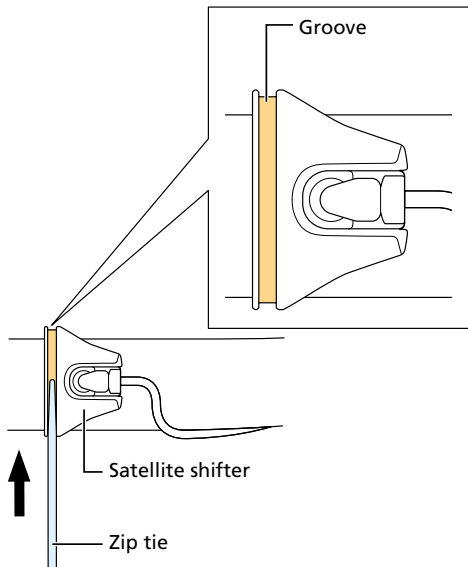

4. Cut the remaining part of the zip tie using cutters, etc.

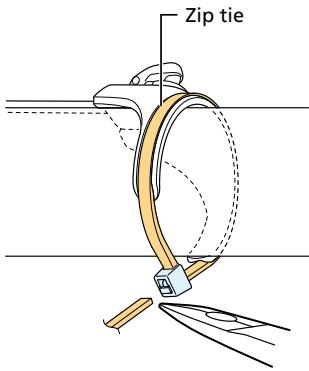

5. Connect the electric wire of the satellite shifter to the satellite shifter connection port of the dual control levers.

There is an alignment tab on the plug of the electric wire, which should be aligned with the shape of the satellite shifter connection port.

Be sure to push it in firmly with the TL-EW300 until you feel a click.

For instructions on using the TL-EW300, refer to the ROAD Di2 Series General Guide .

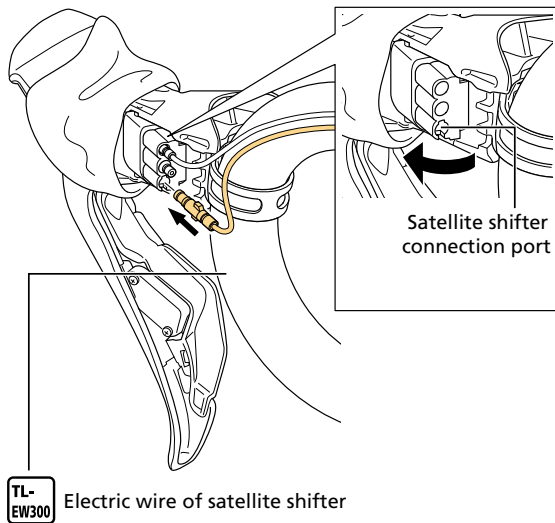

NOTICE

- When passing an electric wire through the frame, handlebar, or other parts, protect the plug with masking tape or a similar material to prevent foreign matter from getting inside.

TECH TIPS

- If there is length to spare in the electric wire of the satellite shifter, retaining it on the dual control lever side will make it easier to remove and insert wiring when performing maintenance.

SW-RS801-E / SW-RS801-S

Routing map

SW-RS801-E

Installation/removal

Installing satellite shifters

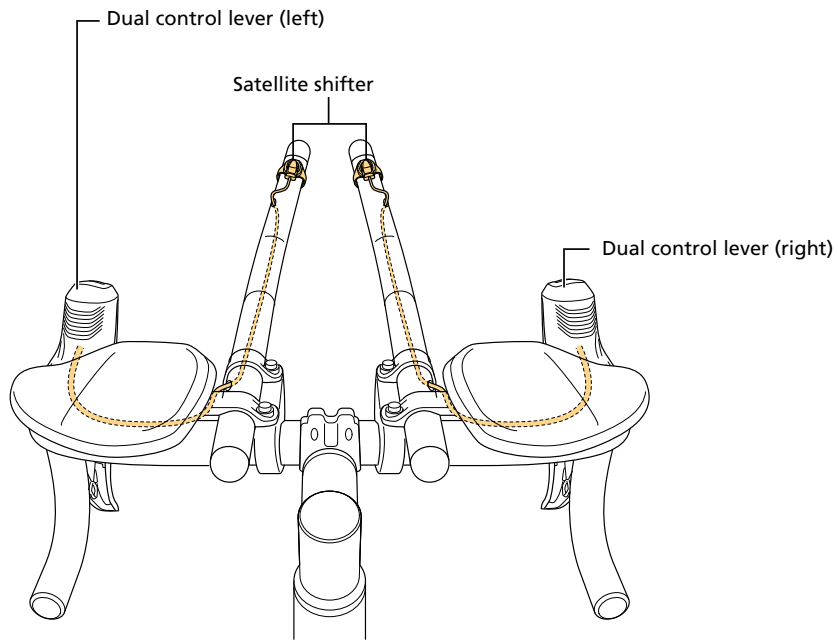

SW-RS801-S

Installation/removal

Installing satellite shifters

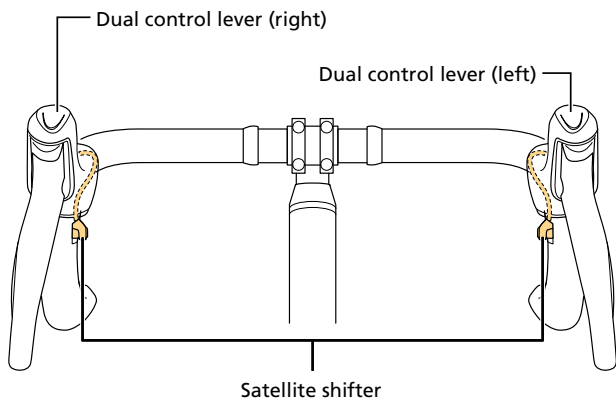

Connection method

1. Use a utility knife or a similar tool to cut the handlebar tape to the length of 80 mm.

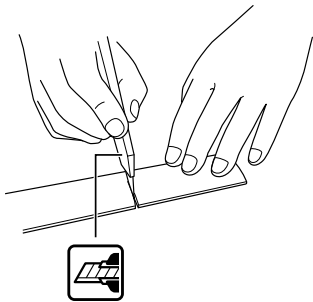

NOTICE

- Make sure that you handle the utility knife safely and correctly in accordance with the instructions which are provided with the utility knife.

Installation/removal

Installing satellite shifters

2. Make a hole in the cut handlebar tape for the button of the satellite shifter to pass through (13 mm x 9 mm).

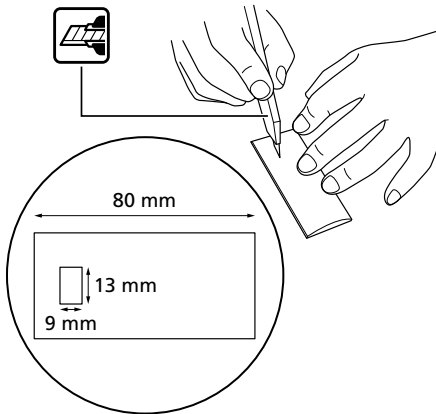

3. Set the band on the shift unit.

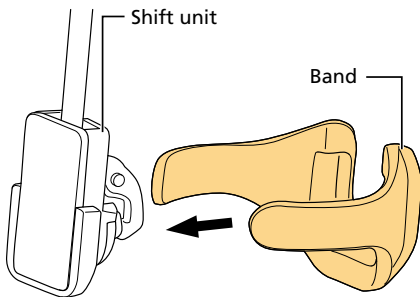

4. Affix double-sided tape to the satellite shifter.

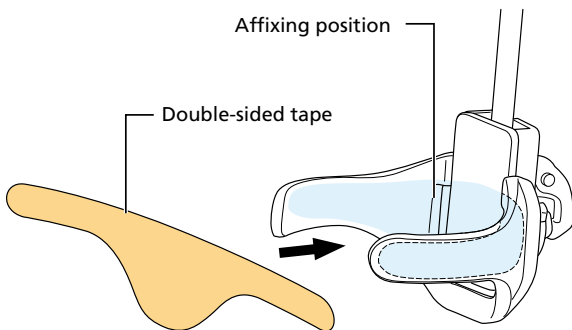

5. Connect the electric wire of the satellite shifter to the satellite shifter connection port of the dual control levers.

There is an alignment tab on the plug of the electric wire, which should be aligned with the shape of the satellite shifter connection port.

Be sure to push it in firmly with the TL-EW300 until you feel a click.

For instructions on using the TL-EW300, refer to the ROAD Di2 Series General Guide .

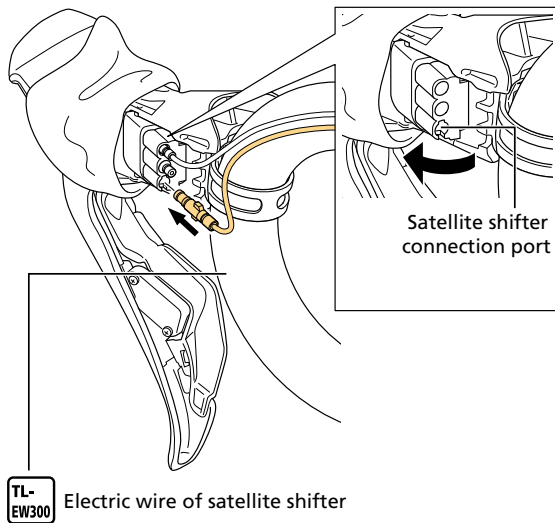

NOTICE

- When passing an electric wire through the frame, handlebar, or other parts, protect the plug with masking tape or a similar material to prevent foreign matter from getting inside.

Installation/removal

Installing satellite shifters

6. Mark the installation position, and affix the satellite shifter to the handlebar using double-sided tape.

SW-RS801-E

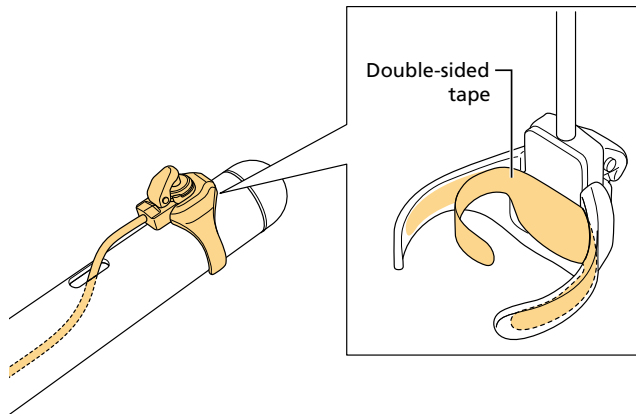

SW-RS801-S

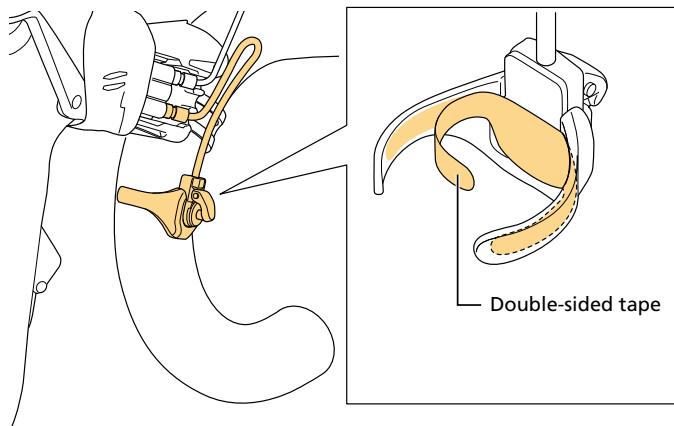

NOTICE

- The adhesive force weakens if there is any dirt, water or oil on the surface where the double-sided tape is applied.

7. Align the cut hole in the handlebar tape with the button.

SW-RS801-E

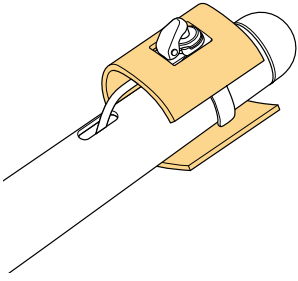

SW-RS801-S

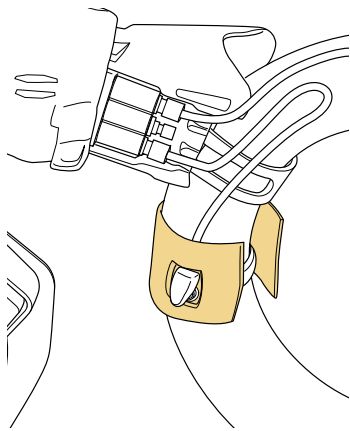

8. Wind on the handlebar tape.

Wind the handlebar tape on securely so that the satellite shifter does not move.

SW-RS801-E

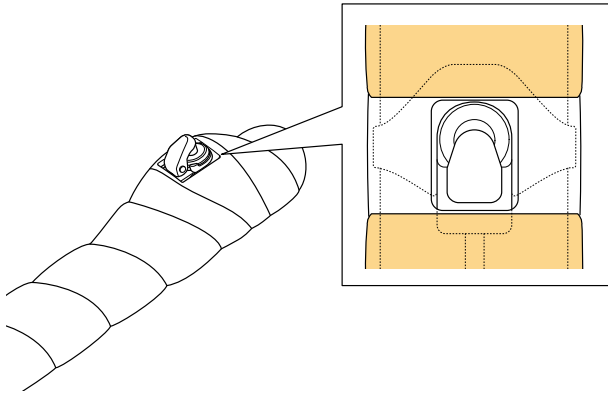

SW-RS801-S

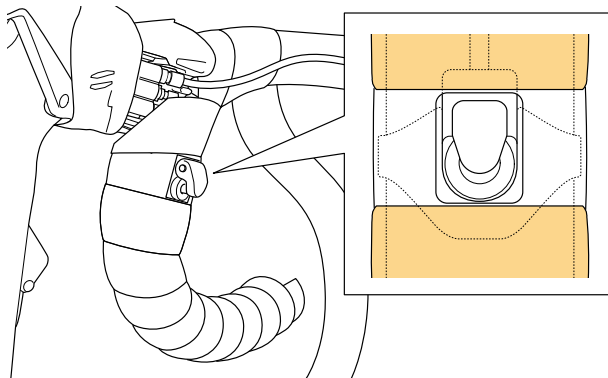

NOTICE

- In order to protect the electric wire, use handlebar tape to secure the wire. Do not secure the wire with the zip tie or the bracket for the cycle computer.

TECH TIPS

- The illustration shows an example of how to wind the handlebar tape.

Troubleshooting

Check the following information if you have a problem.

Installation/removal

Installing the brake calipers

If the problem is not covered below or cannot be solved with the indicated method, contact a distributor.

Symptoms	Causes / possibilities	Remedies
Click cannot be felt when connecting an electric wire. Cannot fully connect a wire.	Is there foreign matter inside the plug or satellite shifter connection port?	Check that there is no foreign matter inside the plug or satellite shifter connection port. If foreign matter is present, use a blower to remove it. If the problem persists, replace the satellite shifter with a new one.

Installing the brake calipers

Recommended tire size/rim outer width/brake shoe

Recommended tire size

The recommended tire sizes for installation are as follows.

Caliper brake	Tire width	Outer diameter of tire
BR-R9200 BR-R9210 BR-R8100 BR-R8110 BR-RS811-R	28 mm or less	Ø684 mm or less

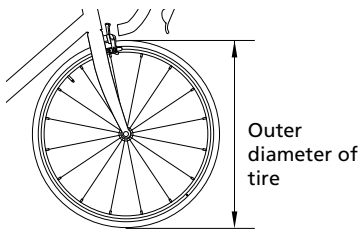

Recommended rim outer width/brake shoes

The recommended rim outer width and brake shoes for installation are as follows.

Installation/removal

Installing the brake calipers

Caliper brake	Rim	Rim outer width		Brake shoe
BR-R9200 BR-R9210 BR-R8100 BR-R8110 BR-RS811-R	Aluminum rim	20.8 - 24 mm	WH-R9100-C60-CL	R55C4 R55CT4
			WH-R9100-C40-CL	
			WH-R9100-C24-CL	
			WH-9000-C50-CL	
			WH-9000-C35-CL	
			WH-9000-C24-CL	
			WH-9000-C24-TL	
	Carbon rim	20.8 - 24 mm	WH-9000-C75-TU	R55C4 (for carbon rim)
			WH-9000-C50-TU	
			WH-9000-C35-TU	
			WH-9000-C24-TU	
		28 mm	WH-R9100-C60-TU	R55C4-A (for carbon rim)
			WH-R9100-C40-TU	
			WH-R9200-C36-TU	
WH-R9200-C50-TU				
WH-R9200-C60-HR-TU				

WARNING

- Brakes designed for use as rear brakes should not be used as front brakes. Also, brakes designed for use as front brakes should not be used as rear brakes.

NOTICE

- Use brake shoes that are appropriate for the rim type and rim outer width.
- BR-R9210 / BR-R8110 / BR-RS811-R

Do not remove the assembly tool until installation is finished. Otherwise the brake caliper may be scratched.

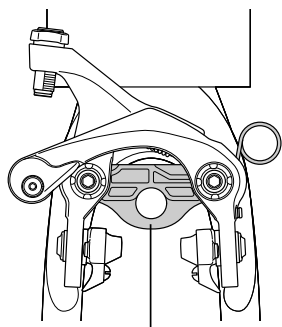

Assembly tool

Installing the brake caliper (BR-R9200 / BR-R8100)

1. Install the brake caliper to the frame.

Depress the arch of the brake caliper and push the brake shoes firmly against the rim.

5 8 - 10 N·m

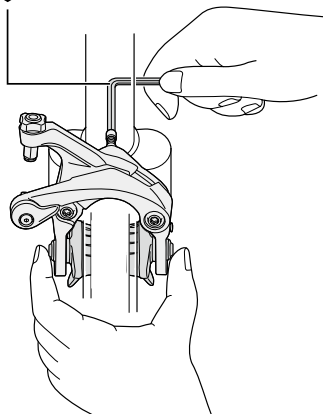

Installation/removal

Installing the brake calipers

2. Check that the centering adjustment screw is in the standard position.

With the standard position, the centering adjustment screw protrudes as shown in the figure. If the centering adjustment screw is not in the standard position, turn it for adjustment.

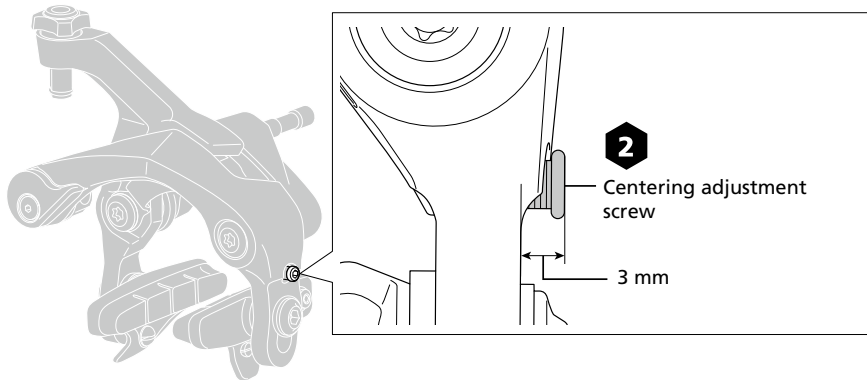

Installing the brake caliper (BR-R9210 / BR-R8110)

Installing the front brake caliper

1. Temporarily install the brake caliper to the frame base.

Install it together with the assembly tool.

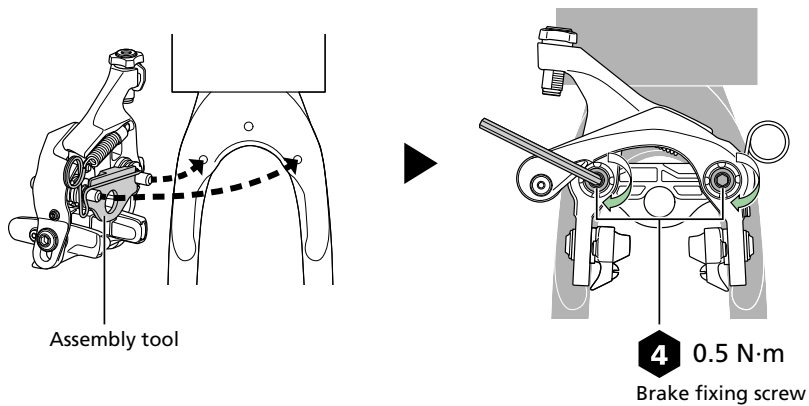

Installation/removal

Installing the brake calipers

2. Remove the wire portion of the assembly tool pulling in the direction of (1), then remove the plastic spacer portion of the assembly tool in the direction of (2).

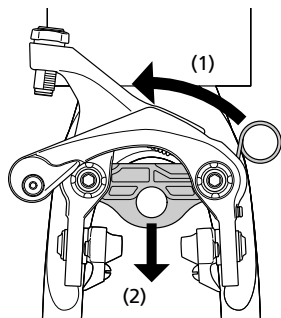

3. Secure the brake caliper to the frame base.

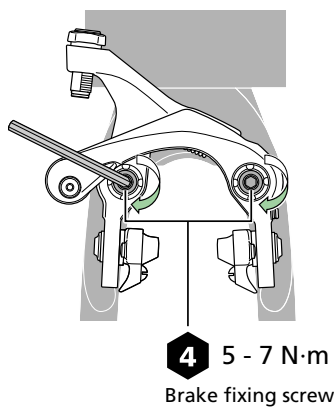

4. Remove the protection sheet.

Installing the rear brake caliper (BR-R9210-RS / BR-R8110-RS)

1. Temporarily install the brake caliper to the frame base.

Install it together with the assembly tool.

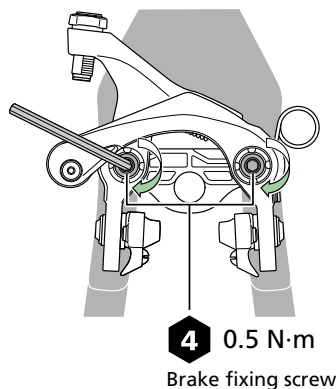
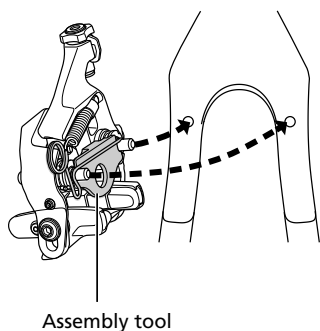

Installation/removal

Installing the brake calipers

2. Remove the wire portion of the assembly tool pulling in the direction of (1), then remove the plastic spacer portion of the assembly tool in the direction of (2).

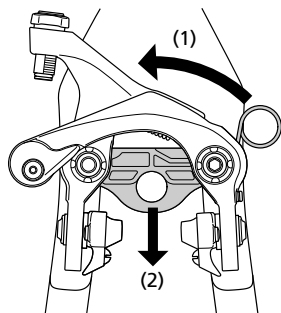

3. Secure the brake caliper to the frame base.

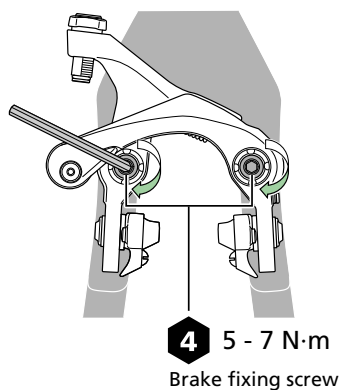

4. Remove the protection sheet.

Installing the brake caliper (BR-RS811-R)

1. Temporarily install the brake caliper to the frame base.

Install it together with the assembly tool.

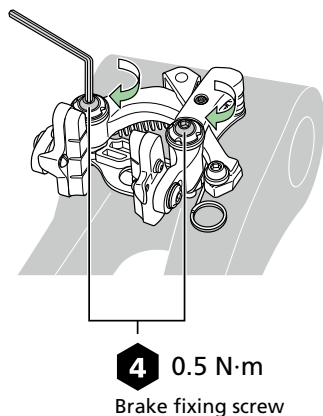

2. Pull out the assembly tool in the direction of the arrow.

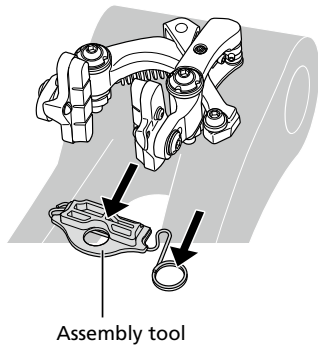

3. Secure the brake caliper to the frame base.

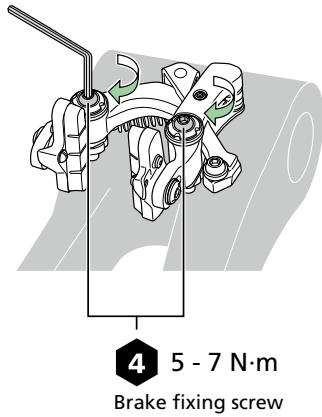

4. Remove the protection sheet.

Brake shoe setting position

The contact angle (toe-in) of the brake shoe against the rim can be adjusted. Setting toe-in enables smooth braking operation.

1. Install the brake shoe to the rim surface as shown in the figure.

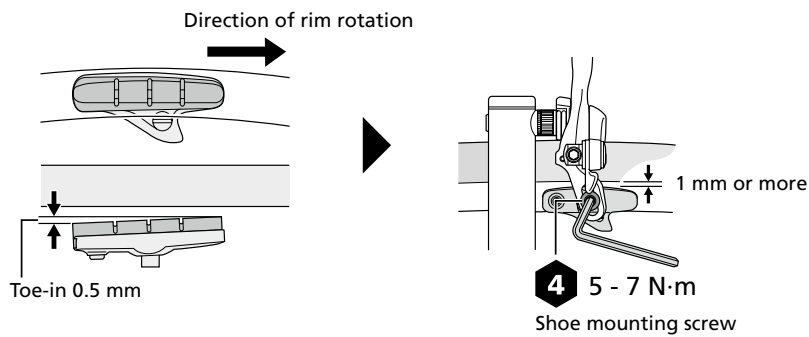

NOTICE

- Use brake shoes that are appropriate for the rim type and rim outer width. For details, refer to the " Recommended tire size/rim outer width/brake shoe " section.

Securing the BC-9000 cable

⚠ WARNING

- When an inner cable is passed through the outer casing, be sure to wipe the fixing section of the inner cable before securing the cable. Residual grease in the area of the clamp screw may prevent sufficient holding force.

NOTICE

- When feeding the BC-9000 inner cable through the shift lever or caliper brake, try to minimize the contact between the cable and the components. If the coating of the cable gets abraded during installation, it may develop a fuzzy appearance, although this will not affect performance.

Installation/removal

Securing the BC-9000 cable

1. Move the quick release lever to the "Close" position.

BR-R9200 / BR-R9210-F / BR-R9210-RS /
BR-R8100 / BR-R8110-F / BR-R8110-RS

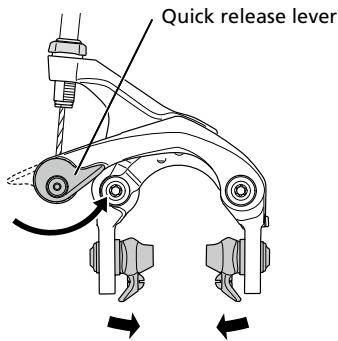

BR-RS811-R

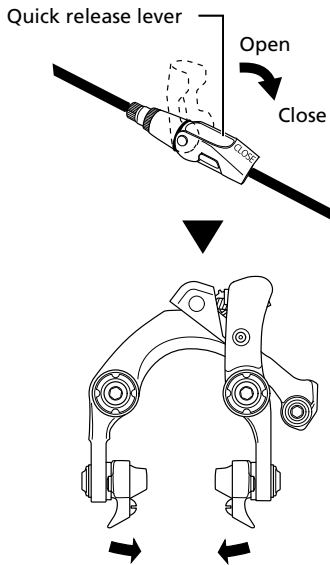

2. Wipe off any grease or other lubricants on the inner cable fixing section.

3. Secure the inner cable.

Turn the centering adjustment screw to adjust the shoe clearance to be the same on the left and right (1.5 - 2 mm).

BR-R9200 / BR-R9210-F / BR-R9210-RS /
BR-R8100 / BR-R8110-F / BR-R8110-RS

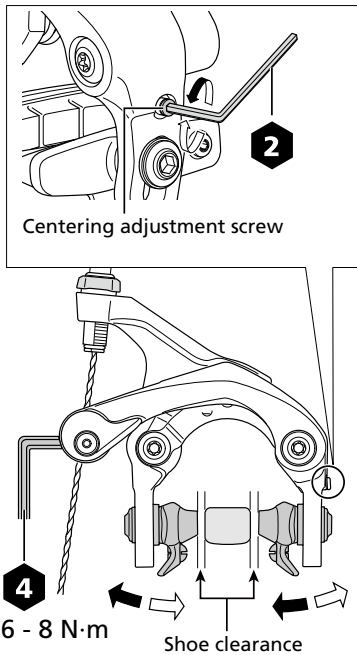

BR-RS811-R

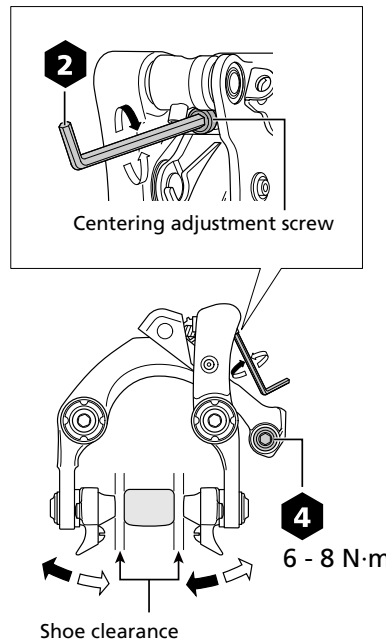

4. Cut off any excess inner cable.

Install the inner end cap.

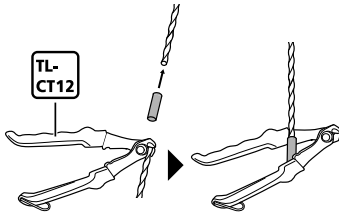

5. After depressing the brake lever several times, there may be a change in the shoe clearance. If necessary, adjust the shoe clearance again to be the same on the left and right (1.5 - 2 mm).

Adjust the shoe clearance to be the same on the left and right (1.5 - 2 mm).

BR-R9200 / BR-R9210-F / BR-R9210-RS /
BR-R8100 / BR-R8110-F / BR-R8110-RS

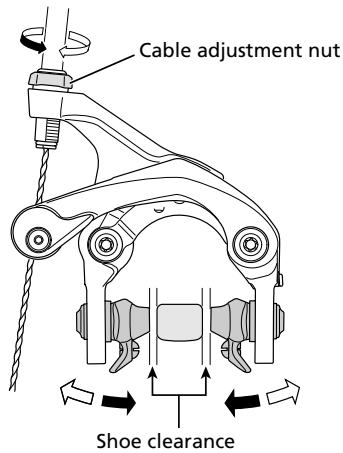

BR-RS811-R

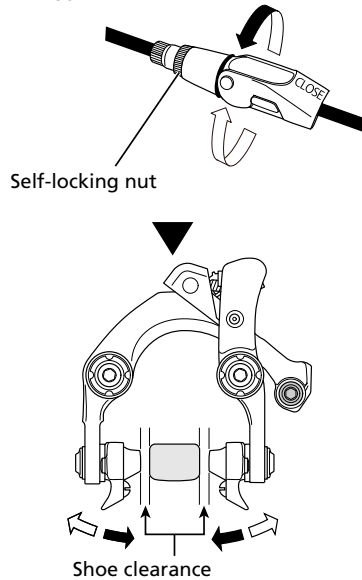

6. Depress the brake lever until it touches the grip about ten times to re-check shoe clearance and each component for any abnormalities.

Cable outer stopper position and appropriate outer casing length (BR-RS811-R)

When caliper brake is open

When the caliper brake is in its resting position, ensure the edge of the outer casing is at least 15 mm from the smallest chainring. ($A \geq 15 \text{ mm}$)

Installation/removal

Securing the BC-9000 cable

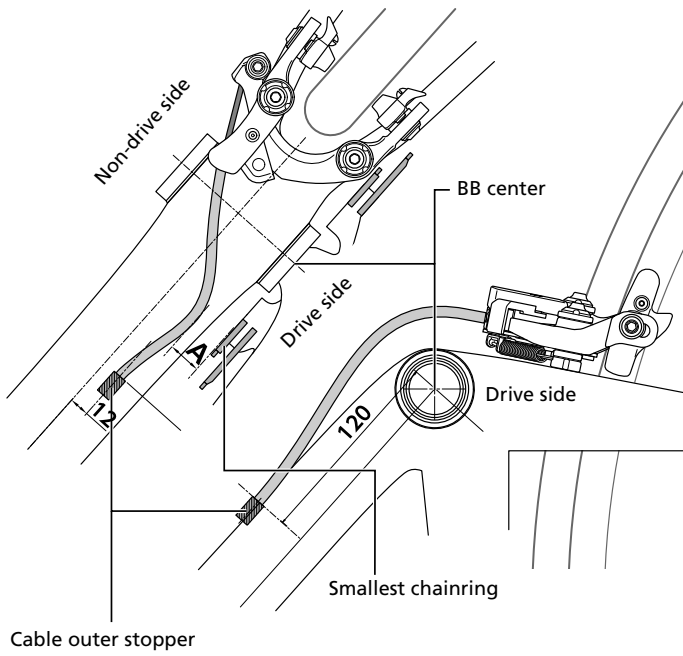

When caliper brake is fully closed

When the caliper is fully closed without a rear wheel, the brake outer casing should be long enough to reach from the cable outer stopper to the caliper.

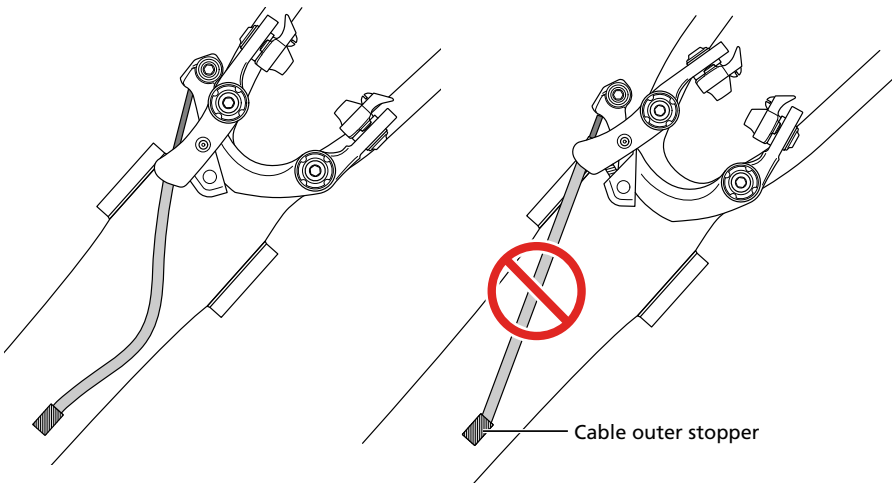

Adjustment

Arch spring tension adjustment

BR-RS811-R

If the brake lever is not returning smoothly, you may need to adjust the fixing position of the spring. Perform this task with the brake caliper removed from the frame.

When using assembly tool

The Assembly Tool (Y8L398040) can aid in reinstallation of the brake caliper after repositioning the spring.

1. **Remove the brake caliper from the frame.**
2. **Reposition the spring.**

Securely attach the spring to the spring attachment pin.

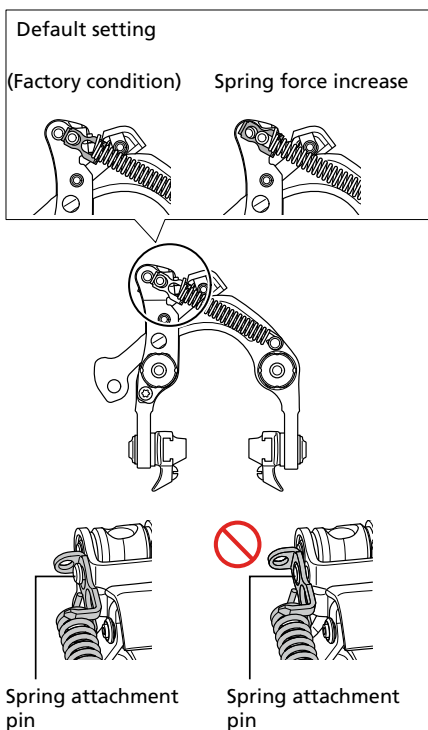

Adjustment

Arch spring tension adjustment

3. Install the assembly tool to the brake caliper.

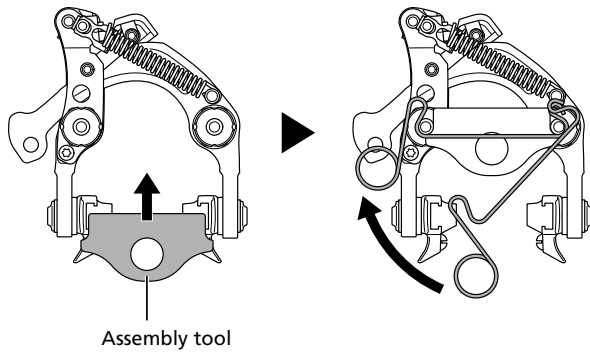

4. Temporarily install the brake caliper to the frame base.

Install it together with the assembly tool.

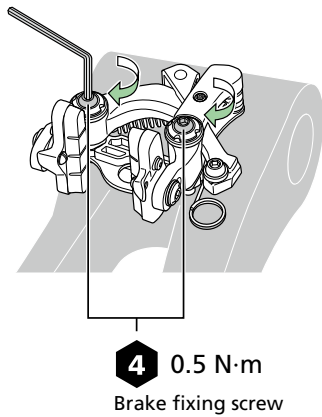

5. Pull out the assembly tool in the direction of the arrow.

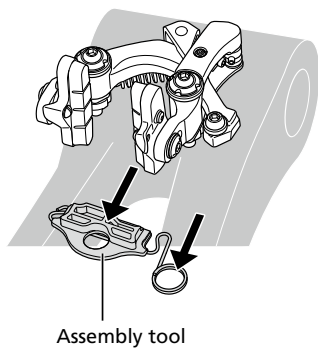

Adjustment

Arch spring tension adjustment

6. Secure the brake caliper.

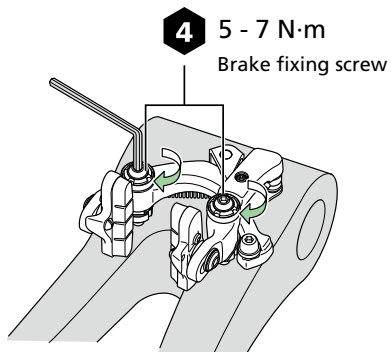

When not using assembly tool

1. Remove the brake caliper from the frame.

2. Reposition the spring.

Securely attach the spring to the spring attachment pin.

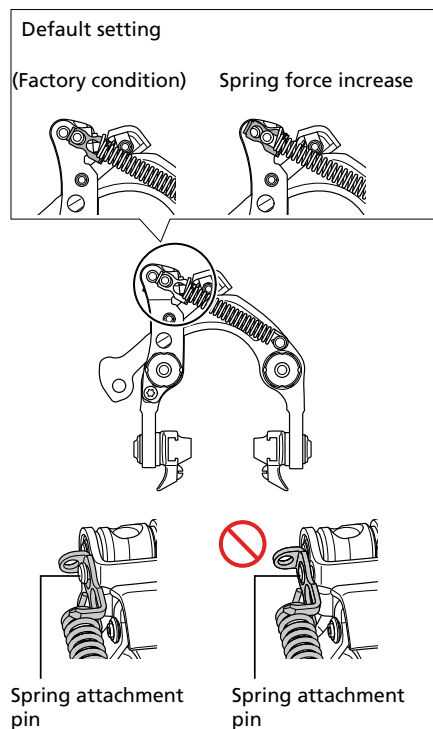

Adjustment

Readjustment of shoe clearance (when brake shoes are worn)

3. Temporarily install the brake caliper to the frame base.

- (1) Half-tighten the Y-arm onto the frame.
- (2) Tighten the C-arm onto the frame.

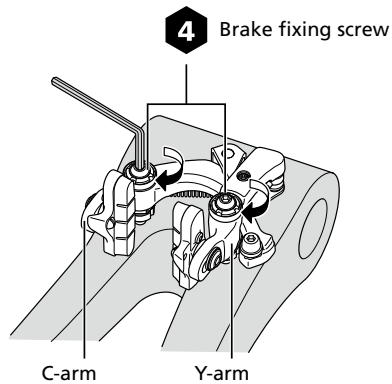

4. Secure the brake caliper.

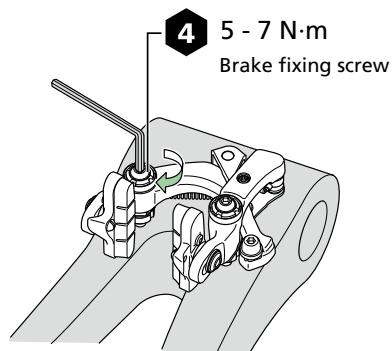

Readjustment of shoe clearance (when brake shoes are worn)

If the clearance with the rim widens due to wear in the brake shoe, readjust the shoe clearance.

Adjustment

Adjusting the reach

1. Turn the cable adjustment nut/self-locking nut to readjust the shoe clearance.

Adjust the shoe clearance to be the same on the left and right (1.5 - 2 mm).

BR-R9200 / BR-R9210-F / BR-R9210-RS /
BR-R8100 / BR-R8110-F / BR-R8110-RS

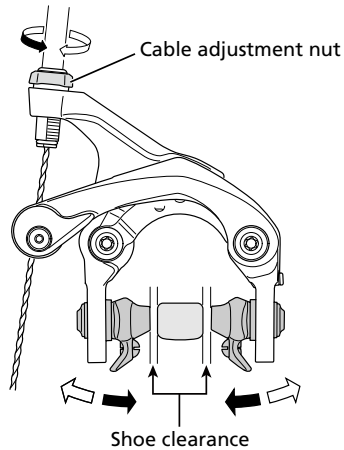

BR-RS811-R

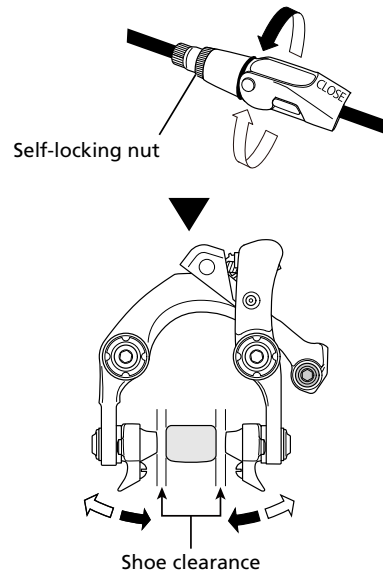

TECH TIPS

- When the grooves of brake shoe are worn away, replace the brake shoe.

Adjusting the reach

1. Turn over the bracket cover from the front side.

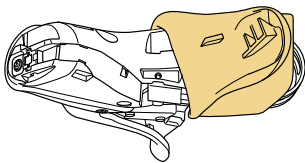

Adjustment

Adjusting the reach

2. Turn the reach adjustment screw to adjust the reach.

Tightening the reach adjustment screw (clockwise) narrows the distance between the initial position of the brake lever and the handlebar, while loosening the screw (counterclockwise) widens it.

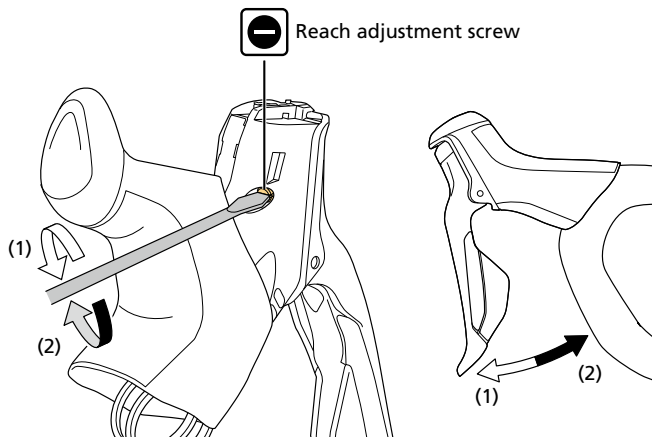

NOTICE

- Use a slotted screwdriver with a blade width of 4.0 - 5.0 mm and blade thickness of 0.5 - 0.6 mm at the tip.
- Make sure that braking operates properly after the adjustment.

Maintenance

Replacing the cartridge shoe

BR-R9200 / BR-R9210-RS / BR-R8100 / BR-R8110-RS

1. Remove the fixing screw.

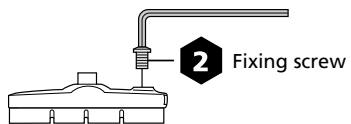

2. Remove the shoe by sliding it along the groove of the shoe holder.

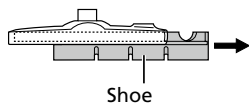

Maintenance

Replacing the cartridge shoe

3. Slide the new shoes into the grooves on the shoe holders to secure them.

There are two different types of shoe and shoe holder for the left and right respectively. Take note of the correct directions and screw hole positions for inserting the shoes.

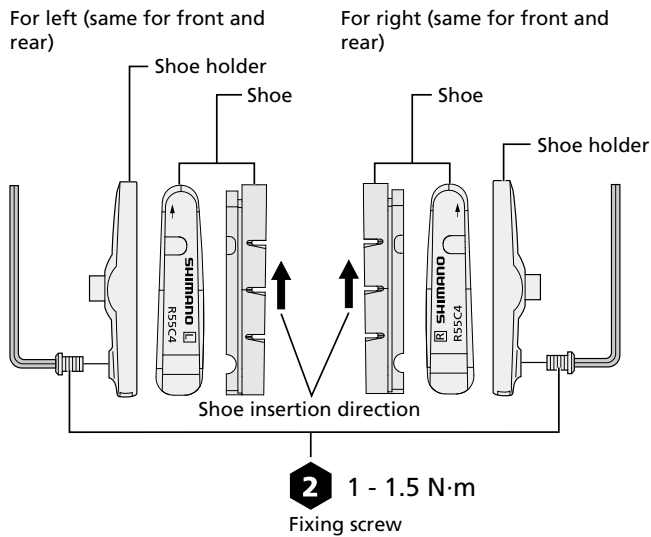

BR-R9210-F / BR-R8110-F / BR-RS811-R

1. Remove the fixing screw.

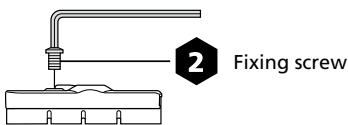

2. Remove the shoe by sliding it along the groove of the shoe holder.

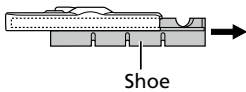

3. Slide the new shoes into the grooves on the shoe holders to secure them.

There are two different types of shoe and shoe holder for the left and right respectively. Take note of the correct directions and screw hole positions for inserting the shoes.

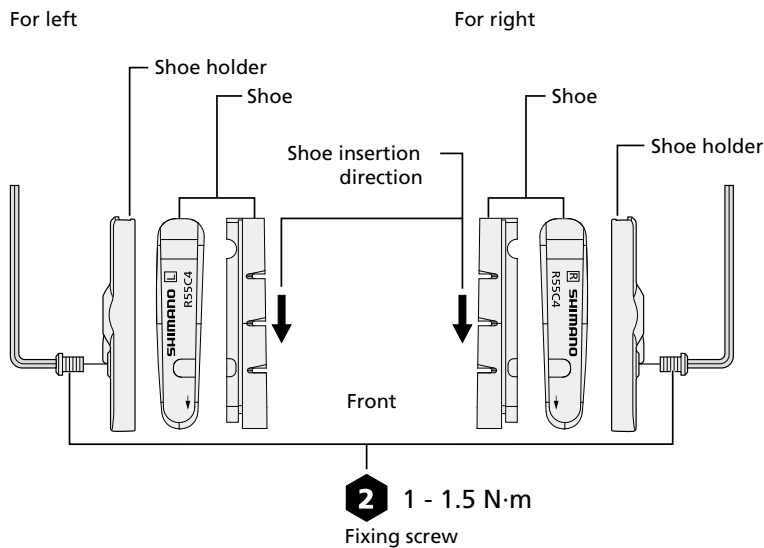

⚠ WARNING

- Make sure to use the dedicated brake shoe for the shoe holder of the BR-R9210-F / BR-R8110-F / BR-RS811-R. Other models of brake shoes have different fixing positions preventing the fixing screw from being tightened, which will cause the brake shoe to come off and disable braking.

Dedicated brake shoes:

R55C4 / R55C4 (for carbon rim) / R55C4-A (for carbon rim) / R55CT4

Brake shoe characteristics

The specifications of the brake shoes are subject to change for product improvement.

Maintenance

Brake shoe characteristics

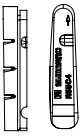
Model No.		R55C4	R55C4 for carbon rim	R55C4-A for carbon rim
Brake shoe shape				
Cartridge type		X	X	X
Recommended rim		Aluminum	Carbon	Carbon
Characteristics	DRY Power	★★★★★	★★★★☆	★★★★☆
	WET Power	★★★☆☆	★★★☆☆	★★★☆☆
	Silence	★★★★☆	★★★☆☆	★★★☆☆
	Anti-fading	★★★★★	★★★★★	★★★★★
	Durability (on-road)	★★★★★	★★★★★	★★★★☆
	Durability (muddy conditions)	★★★★★	★★★★★	★★★★☆
	Anti-rim attack	★★★★☆	★★★★☆	★★★★☆

Maintenance

Replacing the bracket cover

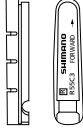
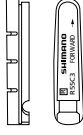
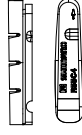
Model No.		R55C3	R55C+1	R55CT4
Brake shoe shape				
Cartridge type		X	X	X
Recommended rim		Aluminum	Aluminum	Aluminum
Characteristics	DRY Power	★★★★★	★★★★☆	★★★★☆
	WET Power	★★☆☆☆	★★☆☆☆	★★☆☆☆
	Silence	★★★★☆	★★★★☆	★★★★☆
	Anti-fading	★★★★★	★★★★★	★★★☆☆
	Durability (on-road)	★★★★★	★★★★☆	★★★★☆
	Durability (muddy conditions)	★★★★★	★★★☆☆	★★★☆☆
	Anti-rim attack	★★★★☆	★★★★★	★★★☆☆

Replacing the bracket cover

1. Remove the brake cables and electric wires from the dual control levers.
2. Remove the dual control levers from the handlebar.

3. Remove the bracket cover.

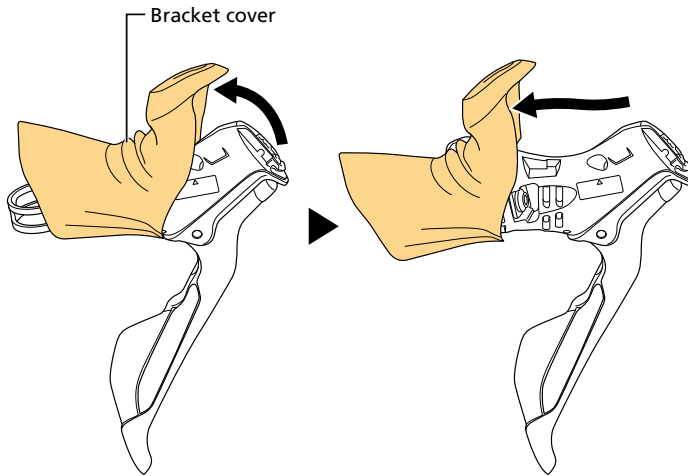

4. Install a new bracket cover.

Insert the protrusions on the bracket cover into the recesses in the bracket body when fitting on the bracket cover.

The inside of the bracket cover has a marking indicating the left side or right side.

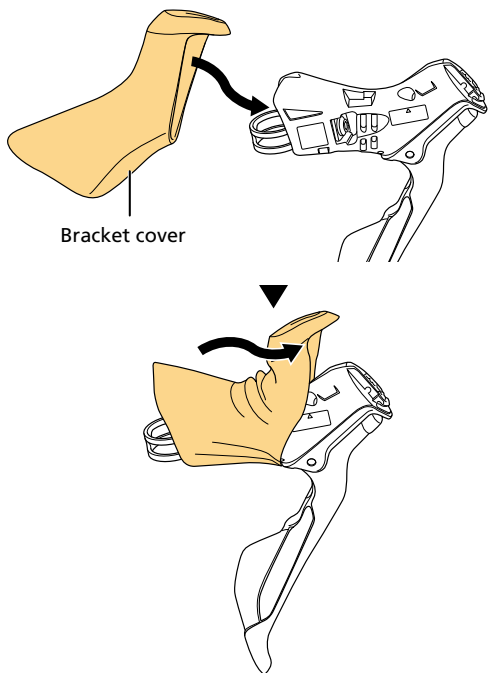

TECH TIPS

- It is easier to perform installation if isopropyl alcohol is applied to the inside of the bracket cover.

5. Reinstall the dual control levers.

- (1) Install the dual control levers to the handlebar.
- (2) Install the electric wires and brake cables to the dual control levers.

SHIMANO

SHIMANO NORTH AMERICA BICYCLE, INC.
One Holland, Irvine, California 92618, U.S.A. Phone: +1-949-951-5003

SHIMANO EUROPE B.V.
High Tech Campus 92, 5656 AG Eindhoven, The Netherlands Phone: +31-402-612222

SHIMANO INC.
3-77 Oimatsu-cho, Sakai-ku, Sakai City, Osaka 590-8577, Japan

Please note: specifications are subject to change for improvement without notice. (English)
© Oct. 2022 by SHIMANO INC. ITP