

Dealer's Manual

ROAD	MTB	Trekking
City Touring/ Comfort Bike	URBAN SPORT	E-BIKE

HUB SET (DISC BRAKE)

Non-Series

HB-MT410

FH-MT410

FH-MT401

CONTENTS



CONTENTS	2
IMPORTANT NOTICE	3
TO ENSURE SAFETY	4
LIST OF TOOLS TO BE USED	7
INSTALLATION/REMOVAL	8
Spoke lacing	8
Installing the disc brake rotor	8
• Quick release type	8
• E-THRU axle type	9
MAINTENANCE	10
Front hub	10
• Disassembly	10
• Assembly	12
Freehub	17
• Disassembly	17
• Assembly	22
• Replacing the freehub body unit	28

IMPORTANT NOTICE

- **This dealer's manual is intended primarily for use by professional bicycle mechanics.**
Users who are not professionally trained for bicycle assembly should not attempt to install the components themselves using the dealer's manuals.
If any part of the information on the manual is unclear to you, do not proceed with the installation. Contact your place of purchase or a distributor for assistance.
- Make sure to read all manuals included with the product.
- Do not disassemble or modify the product other than as stated in the information contained in this dealer's manual.
- All manuals and technical documents are accessible online at <https://si.shimano.com>.
- For consumers who do not have easy access to the internet, please contact a SHIMANO distributor or any of the SHIMANO offices to obtain a hardcopy of the User's Manual.
- Please observe the appropriate rules and regulations of the country, state or region in which you conduct your business as a dealer.

For safety, be sure to read this dealer's manual thoroughly before use, and follow it for correct use.

The following instructions must be observed at all times in order to prevent personal injury and physical damage to equipment and surroundings.
The instructions are classified according to the degree of danger or damage which may occur if the product is used incorrectly.

 DANGER	Failure to follow the instructions will result in death or serious injury.
 WARNING	Failure to follow the instructions could result in death or serious injury.
 CAUTION	Failure to follow the instructions could cause personal injury or physical damage to equipment and surroundings.

TO ENSURE SAFETY

⚠ WARNING

- **Be sure to follow the instructions provided in the manuals when installing the product.**
It is recommended that you use SHIMANO genuine parts. If parts such as bolts and nuts become loose or damaged, the bicycle may suddenly fall over, which may cause serious injury.
-  Wear approved eye protection while performing maintenance tasks such as replacing components.

Be sure to also inform users of the following:

- Check that the wheels are fastened securely before riding the bicycle. Otherwise, you may fall and be seriously injured.
- Before riding the bicycle, you should carefully check your hubs to make sure that there are no cracks in the axles, and if you find any unusual conditions, DO NOT use the bicycle. These hubs are not designed for downhill bicycle riding or freeriding. Depending on the riding conditions, the hub axle could develop cracks. This could result in the failure of the wheel axle, which can lead to an accident resulting in serious injury or even death.
- HB-MT410 can only be used in combination with the special front fork and through axle. If it is used in combination with any other front fork or through axle, it may cause the wheel to become detached from the bicycle during riding and result in serious bodily injury.
- The FH-MT410/FH-MT401 must only be used in combination with special frames and through axles.
If used with any other type of frame, the wheel may come off while the bicycle is being ridden, and serious injury may occur as a result.
- If the axle release lever / quick release lever is on the same side as the disc brake rotor, there is the danger that it may interfere with the disc brake rotor. Make sure that, even if the axle release lever / quick release lever is tightened as much as possible by hand, the axle release lever / quick release lever does not interfere with the disc brake rotor. If the axle release lever/quick release lever interferes with the disc brake rotor, immediately stop use and contact the place of purchase or a distributor.

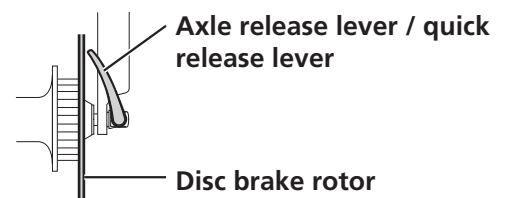

- If it is difficult to install the wheel, install the quick release lever on the disc brake rotor side.

If doing this, make sure that the quick release lever does not interfere with the disc brake rotor and that burns do not occur.

- Make sure to properly install the quick release hub onto the bicycle. Otherwise the wheel may detach from the bicycle while riding, resulting in serious injury.
- Read the quick release lever manual carefully, and keep it in a safe place for later reference.

For installation to the bicycle, and maintenance:

- When installing the front wheel to the front suspension fork, always be sure to follow the directions given in the manual for the front suspension fork. When the front wheel is secured using the tightening torque, the front wheel's rotation may become stiff; however, the instructions must always be followed. The securing method and tightening torque for the front wheel both vary depending on the type of front suspension fork being used. If the instructions are not followed, the front wheel may fall out of the front suspension fork and serious injury may occur.
- When installing the rear wheel to the frame, always be sure to follow the directions given in the manual for the frame. When the rear wheel is secured using the tightening torque, the rear wheel's rotation may become stiff; however, the instructions must always be followed. The securing method and tightening torque for the rear wheel both vary depending on the type of frame being used. Improper handling may cause the rear wheel to fall off and lead to serious injury.
- Read the disc brake manual carefully, and keep it in a safe place for later reference.

Quick release type

- Use a front fork which is equipped with a wheel retention mechanism.

CAUTION

For installation to the bicycle, and maintenance:

- When using the SHIMANO original tool (TL-FC36) to remove and install the disc brake rotor mounting ring, wear gloves and be careful not to touch the outer edges of the disc brake rotor with your hands. Failure to do so may result in cuts to your hands.

NOTICE**Be sure to also inform users of the following:**

- This product is not warranted against damage resulting from improper use, such as jumping while riding or if the bicycle falls over, except if such malfunctions are caused by manufacturing methods.
- Products are not guaranteed against natural wear and deterioration from normal use and aging.
- For maximum performance we highly recommend SHIMANO lubricants and maintenance products.







For installation to the bicycle, and maintenance:

- If the wheel becomes stiff and difficult to turn, apply grease.
- Do not lubricate the internal parts of the hub. Otherwise, grease will flow out.
- When replacing the E-THRU Axle, make sure that the replacement E-THRU Axle is of the same model as the current E-THRU Axle attached to the frame.
A different model may not be mounted properly onto the frame due to differences in axle length, screw size, housing diameter, etc.
- Use the TL-HB16 when attaching the front hub to the wheel truing tool.

The actual product may differ from the illustration because this manual is intended mainly to explain the procedures for using the product.

LIST OF TOOLS TO BE USED

The following tools are needed for installation/removal, adjustment, and maintenance purposes.

Tool	
	2.5 mm hexagon wrench
	5 mm hexagon wrench
	17 mm hub spanner
	TL-FC32
	TL-LR15
	Adjustable wrench
	Bearing press tool

INSTALLATION/REMOVAL

Spoke lacing

1. Lace the spokes as shown in the figure.

Radial lacing is not supported.

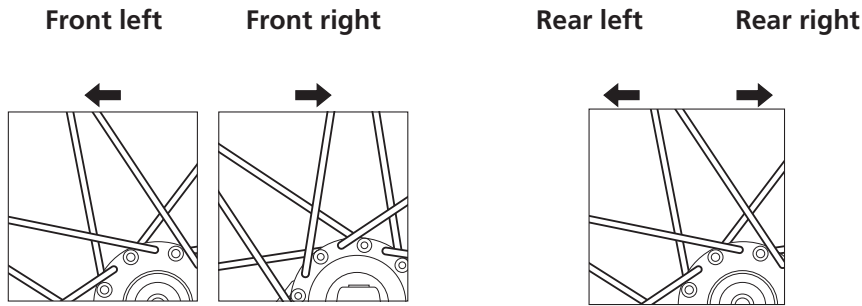

Installing the disc brake rotor

Quick release type

1. Set the disc brake rotor on the hub, and then secure it with the disc brake rotor lock ring.

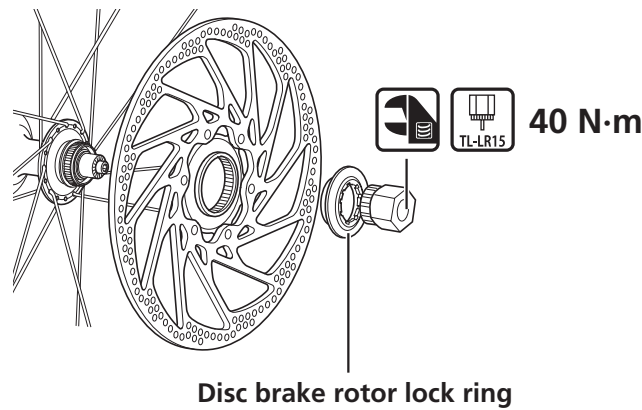

E-THRU axle type

1. Set the disc brake rotor on the hub, and then secure it with the disc brake rotor lock ring.

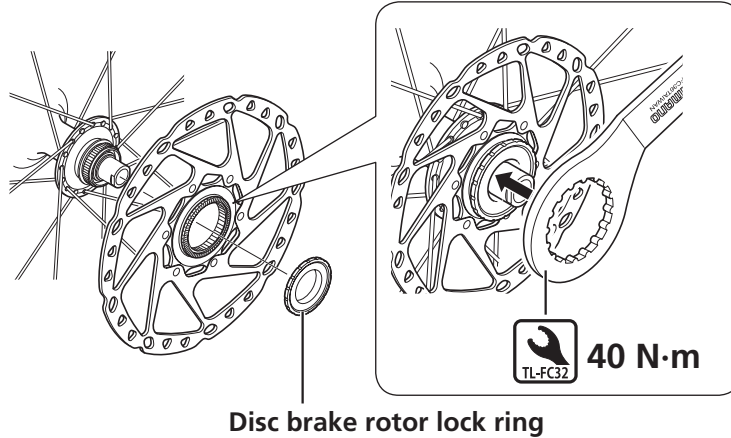

MAINTENANCE

Front hub

Disassembly

1. Remove the left and right axle caps by pulling them outwards off the end of the hub.

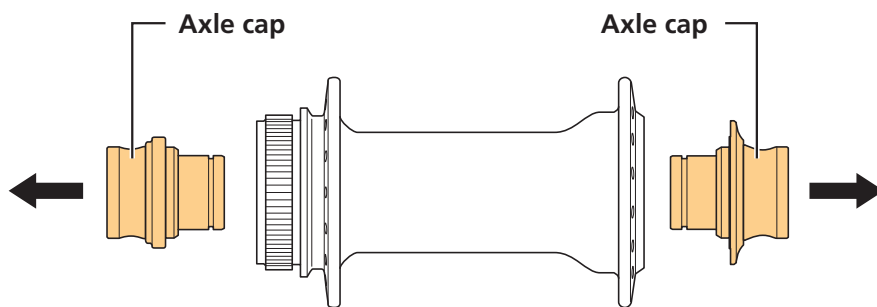

2. Remove the left and right seal rings using a tool such as a slotted screwdriver.

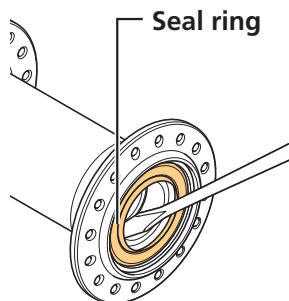

3. Remove the bearing.

- (1) Use a bar (recommended: diameter 10 - 15 mm, length 120 - 150 mm) to push the left side of the bush to tilt it as shown in the figure.

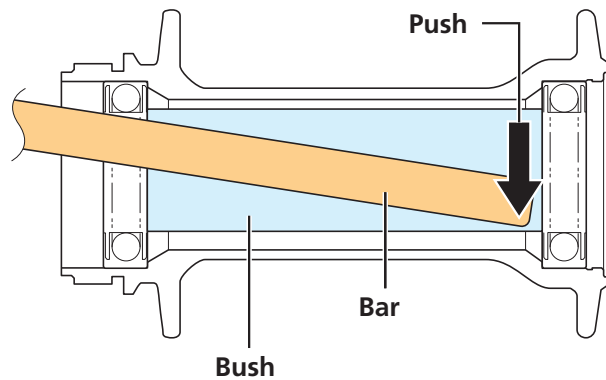

- (2) Touch the left bearing part with the bush shifted and exposed with the bar, and tap it with the hammer to push out the left bearing.
 - The bush can be removed at the same time too.
 - Also push out the right bearing from the other side in the same manner.

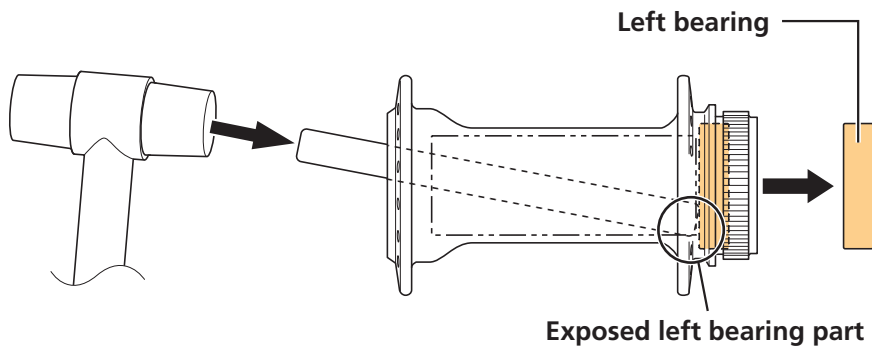

4. The unit can be disassembled as shown in the figure. Apply grease to the indicated parts.

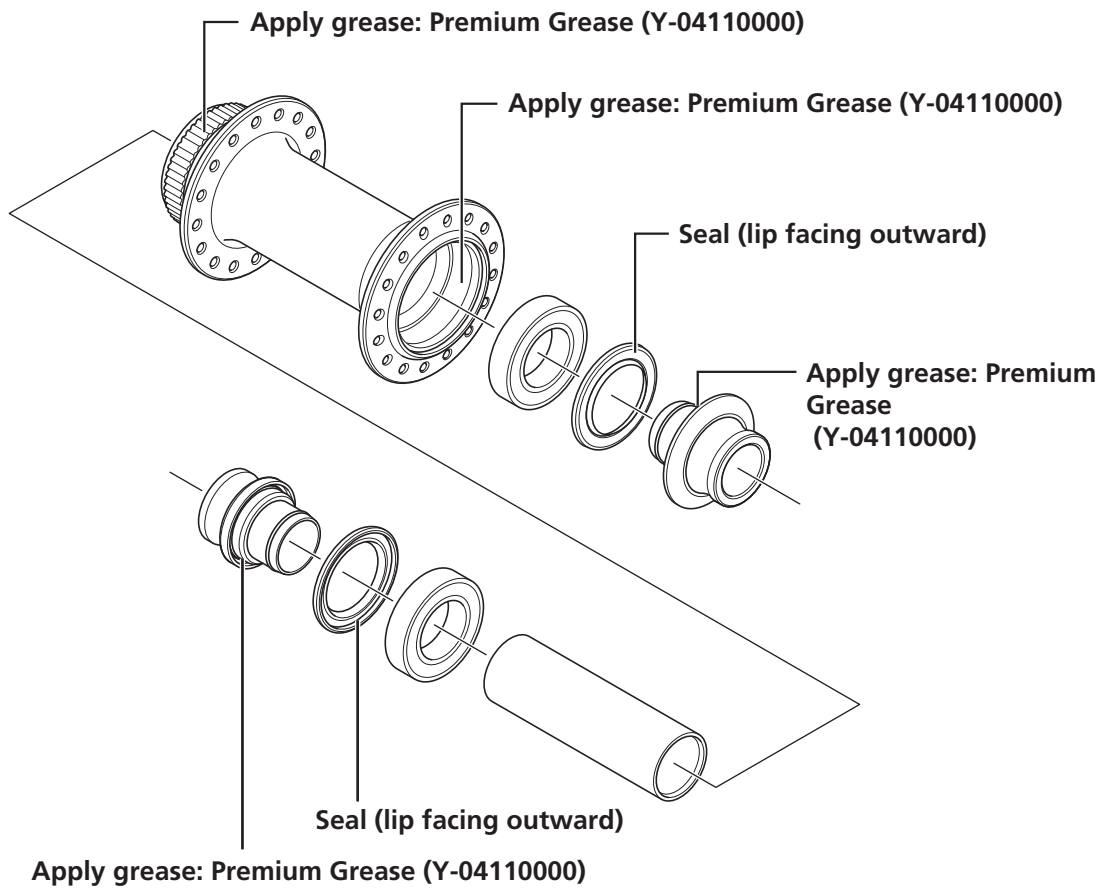

Assembly

1. Apply Premium Grease (Y-04110000) to the hub shell.

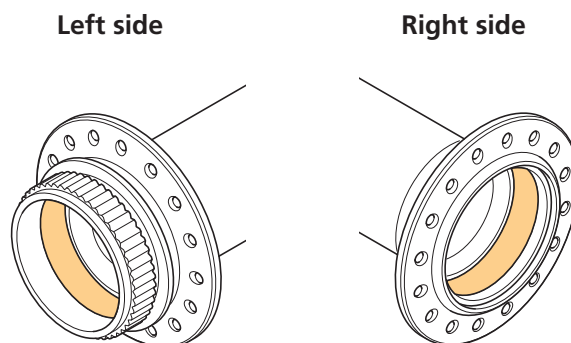

2. Install the right bearing.

- (1) Install the right bearing and bearing press parts to the hub, and set the bearing press tool.

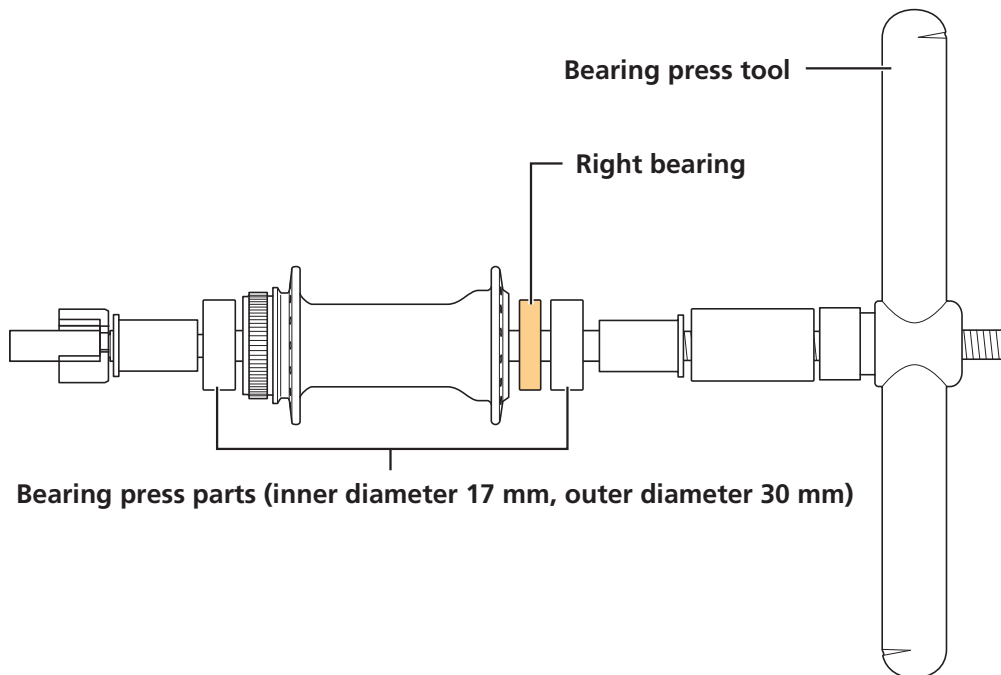

- (2) Turn the handle of the bearing press tool, and insert the right bearing as far as it will go.

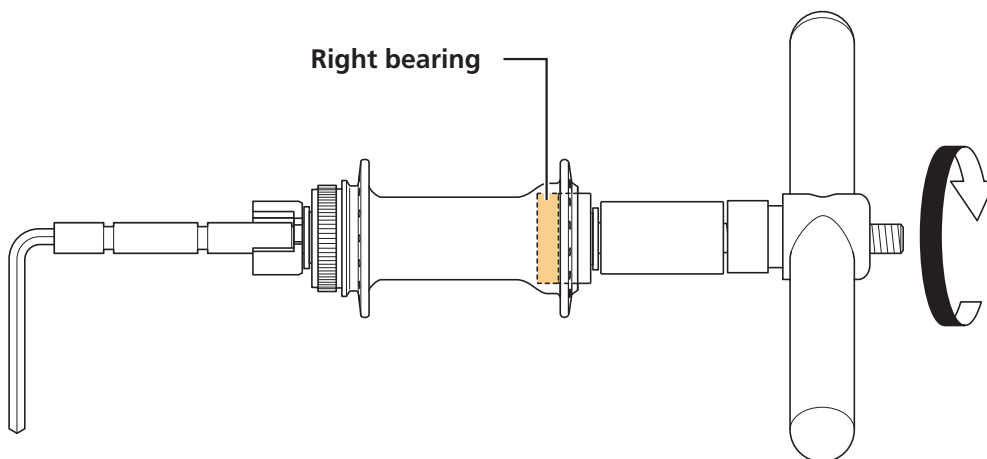

NOTICE

- Be sure to install the bearing from the right side.
- The bearing press part should touch both the outer ring and inner ring of the bearing.

3. Install the left bearing.

- (1) Remove the bearing press tool and bearing press parts, and insert the bush from the left side of the hub.
 - Make sure that the bush is in the center of the hub.

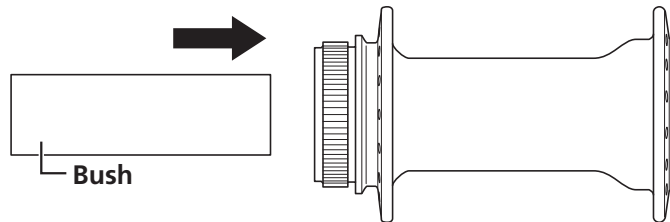

- (2) Install the left bearing and bearing press parts to the hub, and set the bearing press tool.

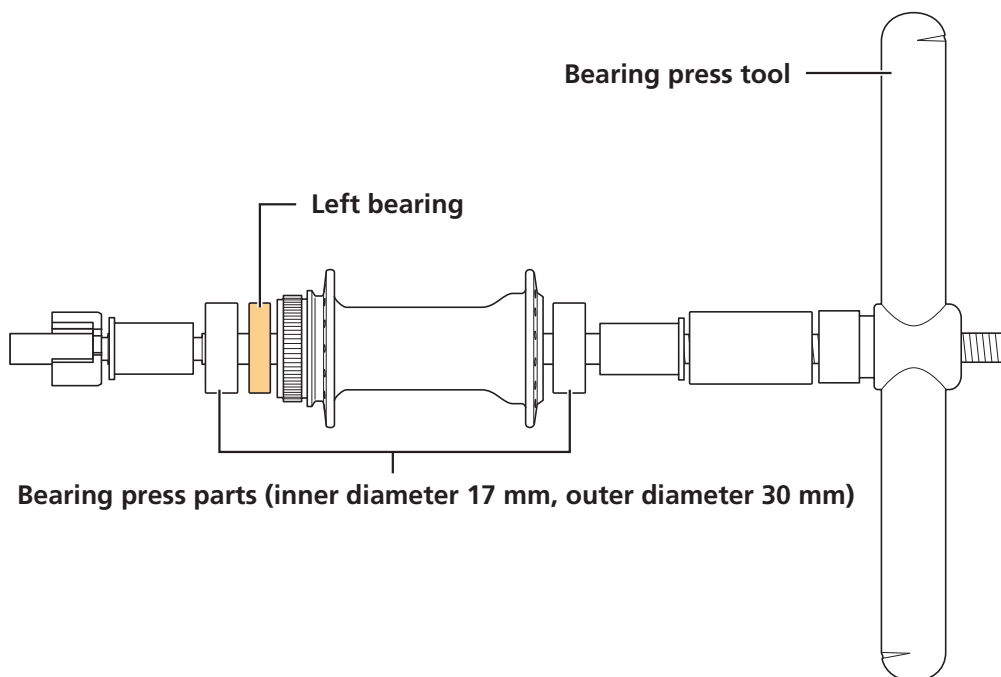

- (3) Turn the handle of the bearing press tool, and insert the left bearing as far as it will go.

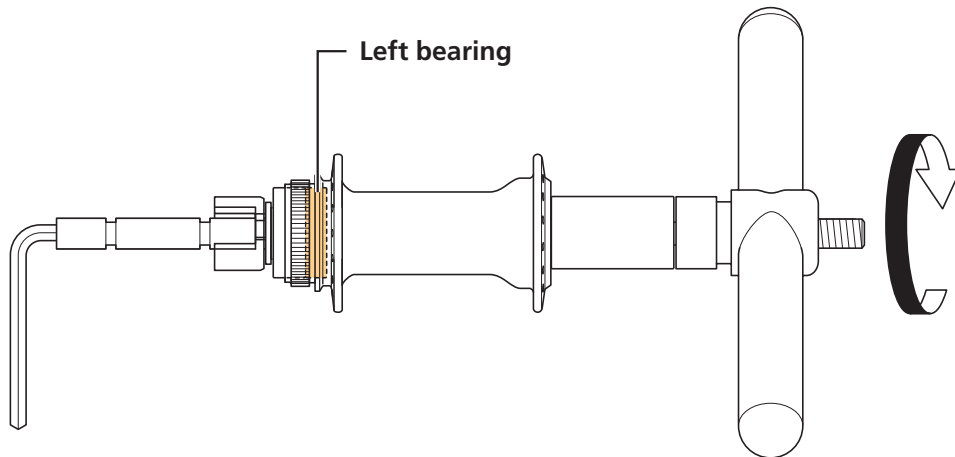

4. Install the left and right seal rings.

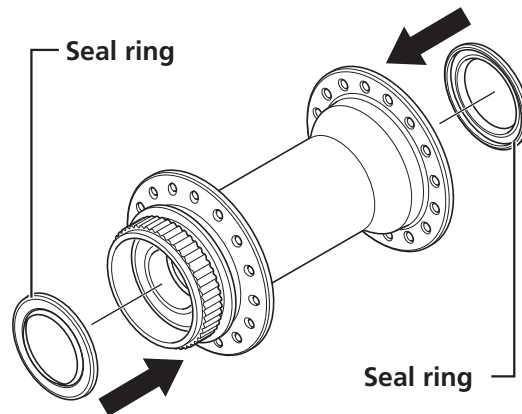

5. Install the left and right axle caps.

Be sure to push the axle caps until they click.

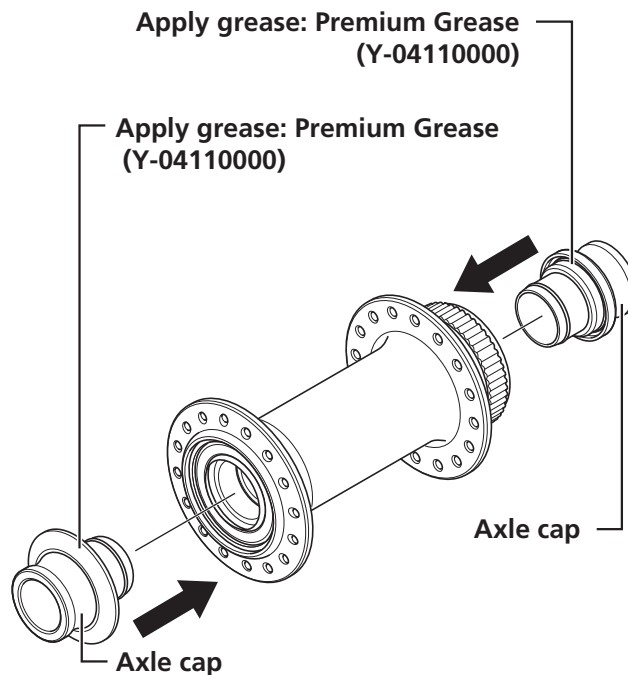

6. Check that the bearing is completely installed using the following procedures.

- (1) Hold the left and right axle caps and move the hub main body in the axle direction to confirm that there is no gap. If there is a gap, perform step 3 to press-fit again. If there is still a gap, perform step 2 again.
- (2) Hold the left and right axle caps and rotate the hub main body to confirm that it rotates smoothly. If it is not smooth, gently tap it with a bar from inside to loosen it as when performing disassembly. When loosening, loosen the right bearing first.

Freehub

NOTICE

- When removing and installing the seal, do so very carefully so that the seal does not become deformed. When reinstalling the seal, check that it is facing the right way and insert it as far as it will go.
- Do not disassemble the dust cover which is crimped onto the right nut.
- Do not attempt to disassemble the freewheel body, because it may result in a malfunction.
- Perform the assembly according to the assembly procedures when the freewheel body has been removed.
- Do not mix the special grease applied to the freewheel body with other grease. Doing so may cause the clutch of the freewheel to malfunction.

Disassembly

1. Remove the freehub body unit by pulling it outwards off the end of the hub.

The right cap will also be removed. Remove the outer seal cap at the same time.

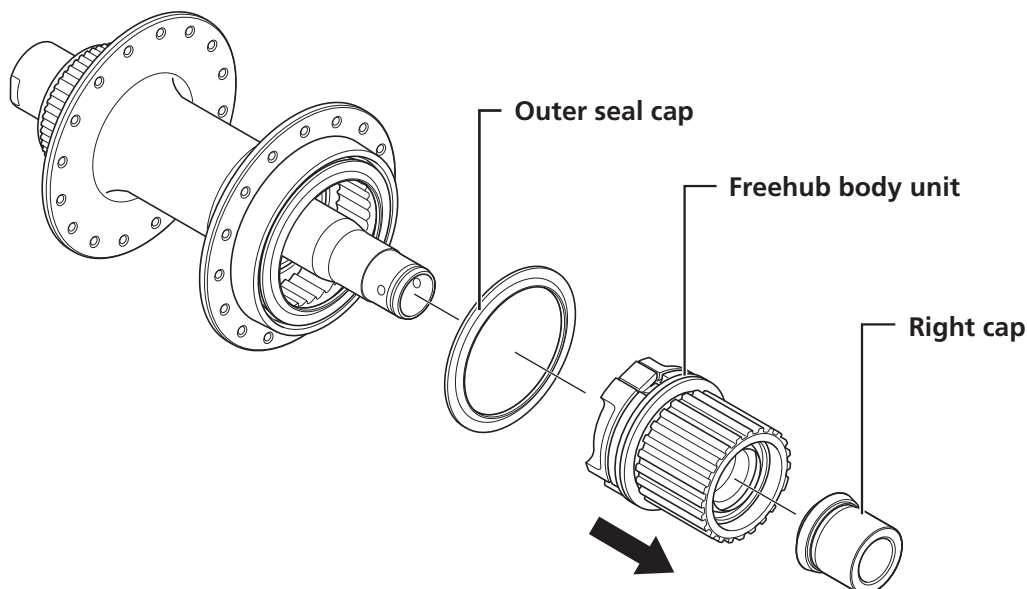

2. Remove the bush.

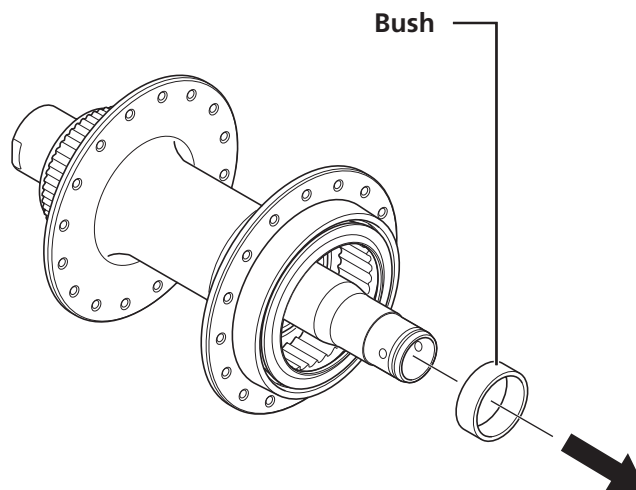

3. Secure the hub axle with a hexagon wrench, and remove the left hand lock nut.

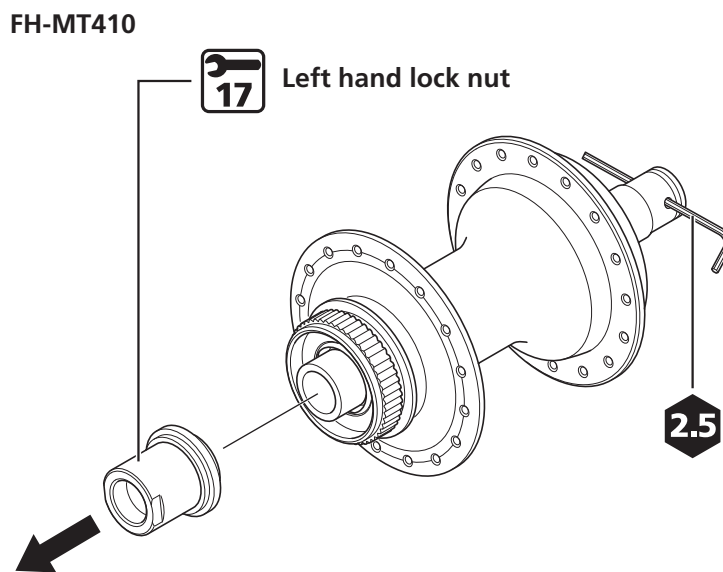

FH-MT401

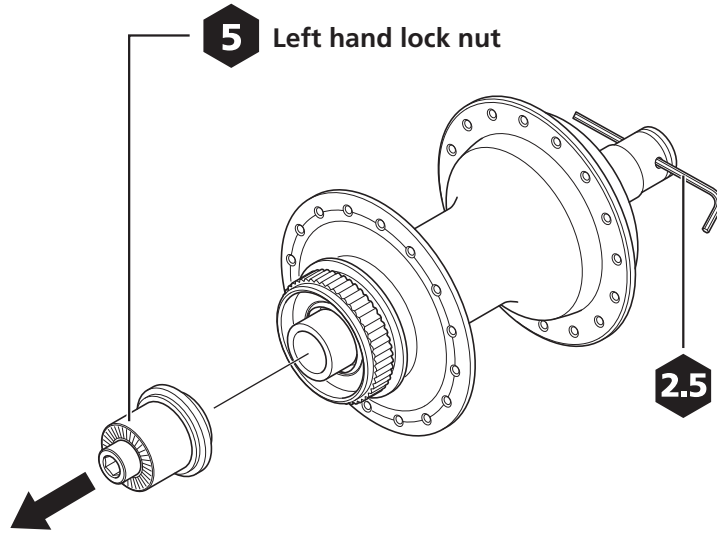

4. Remove the seal ring.

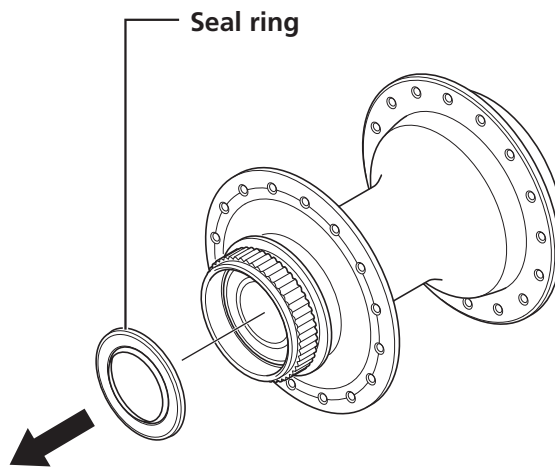

5. Place the right cap over the right side of the hub axle, and tap the right cap from the right side with a hammer to remove the left bearing.

Insert the hub axle covered by the right cap into the left side of the hub shell, and tap the right cap from the left side to remove the right bearing.

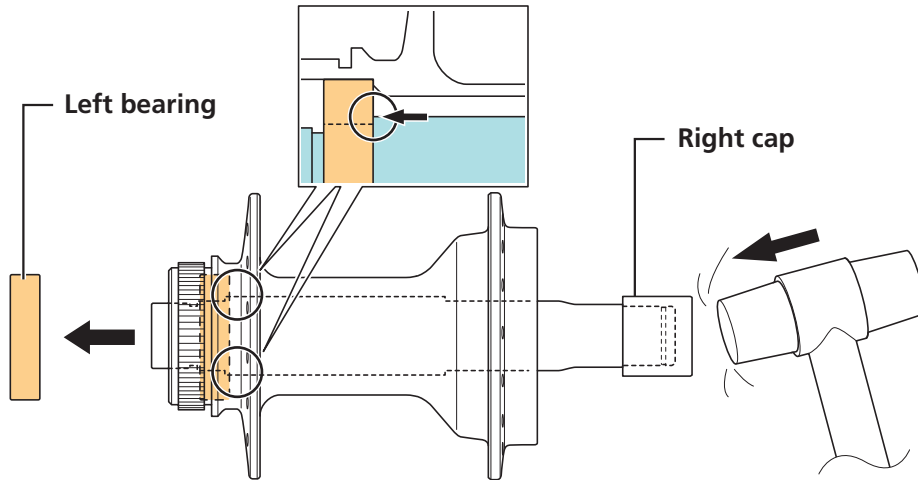

6. The unit can be disassembled as shown in the figure. Apply grease to the indicated parts.

FH-MT410

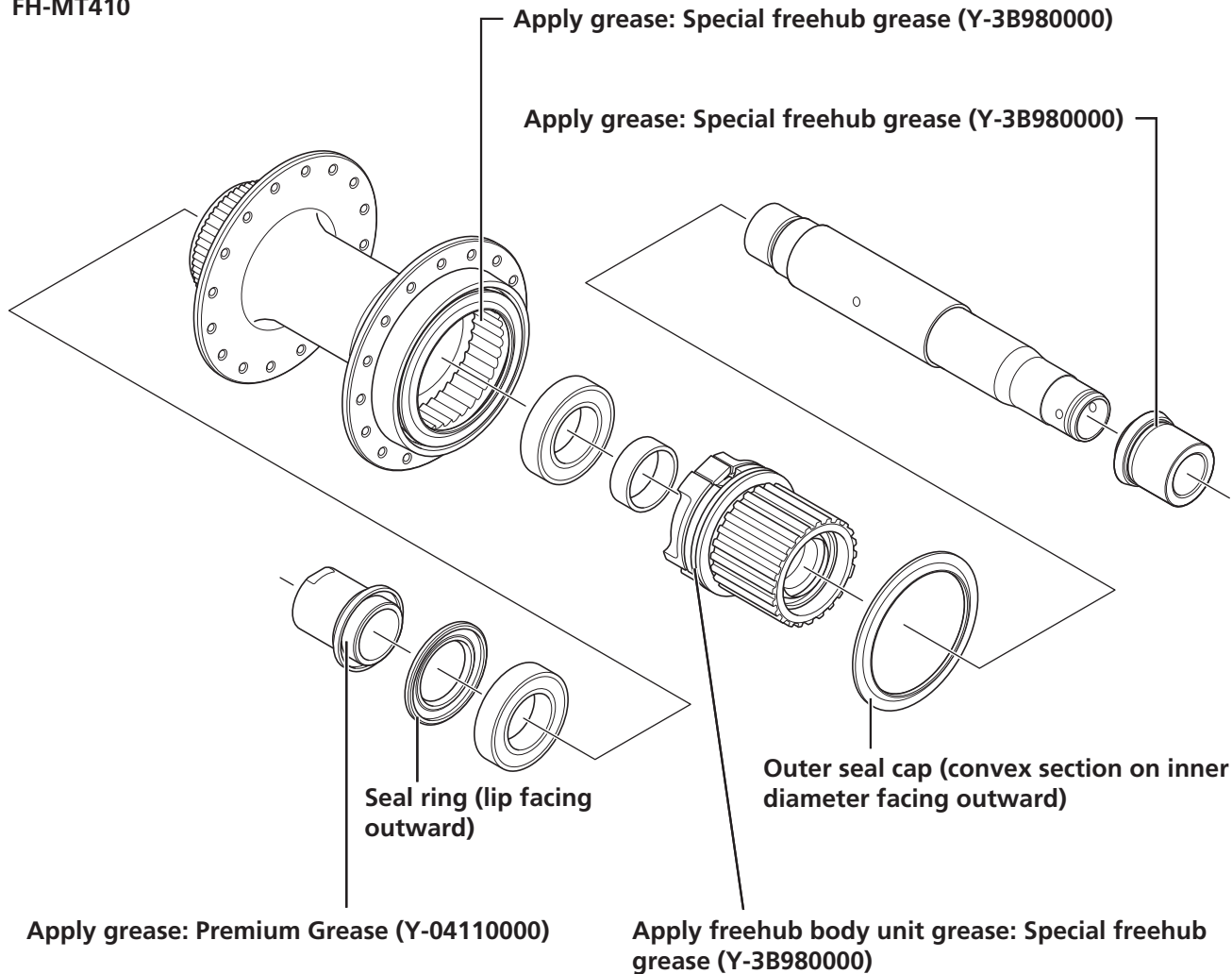

FH-MT401

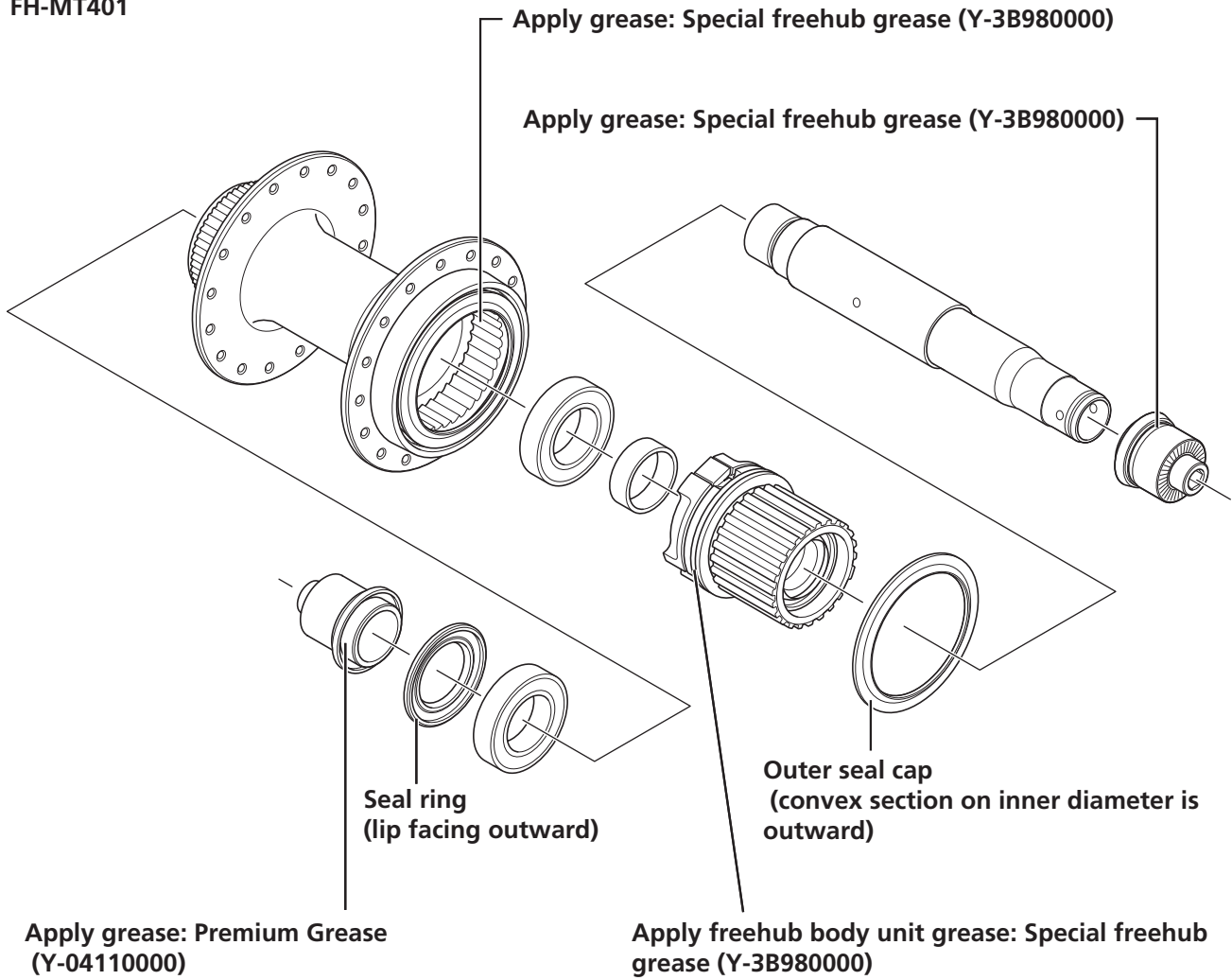

Assembly

1. Apply Premium Grease (Y-04110000) to the hub shell.

Left side

Right side

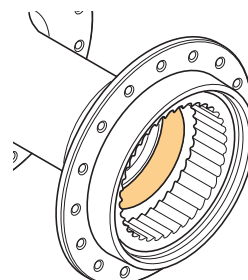
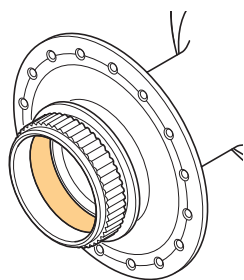

2. Install the left bearing.

- (1) Install the left bearing and bearing press parts to the hub, and set the bearing press tool.

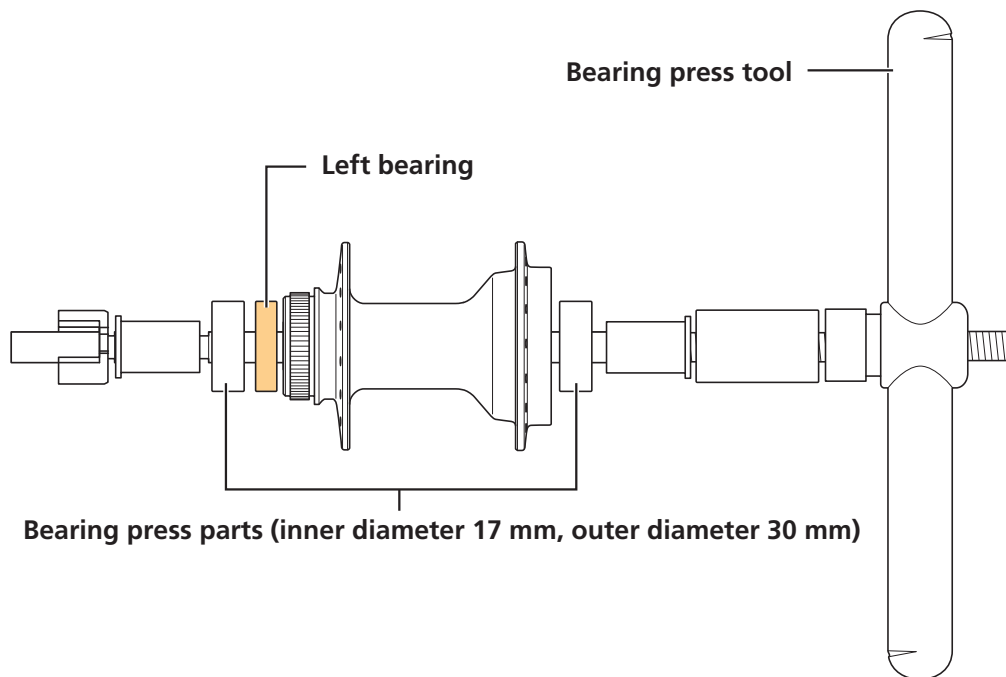

- (2) Turn the handle of the bearing press tool, and insert the left bearing as far as it will go.

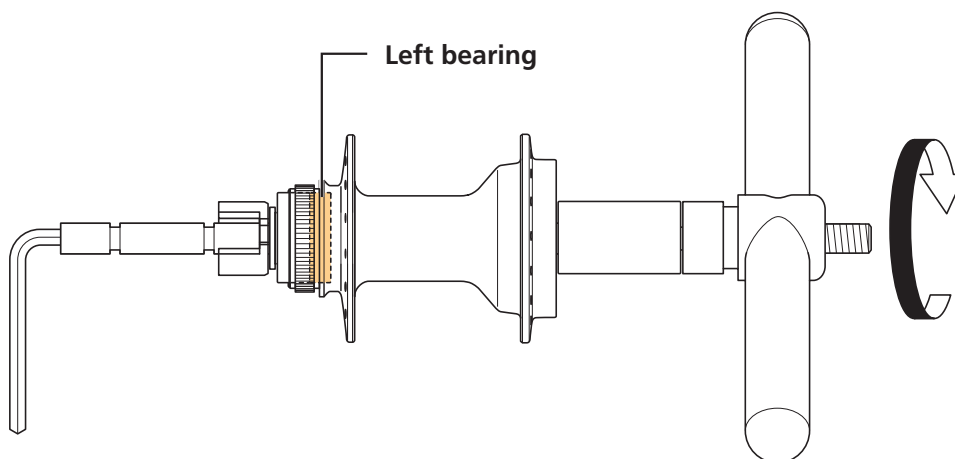

NOTICE

- Be sure to install the bearing from the left side.
- The bearing press part should touch both the outer ring and inner ring of the bearing.

3. Install the right bearing and hub axle to the hub.

- (1) Remove the bearing press tool, and insert the hub axle from the right side of the hub.

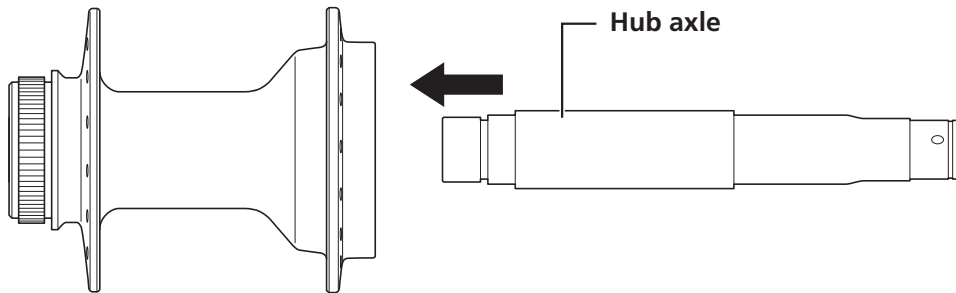

- (2) Install the right bearing and bearing press parts to the hub, and set the bearing press tool.

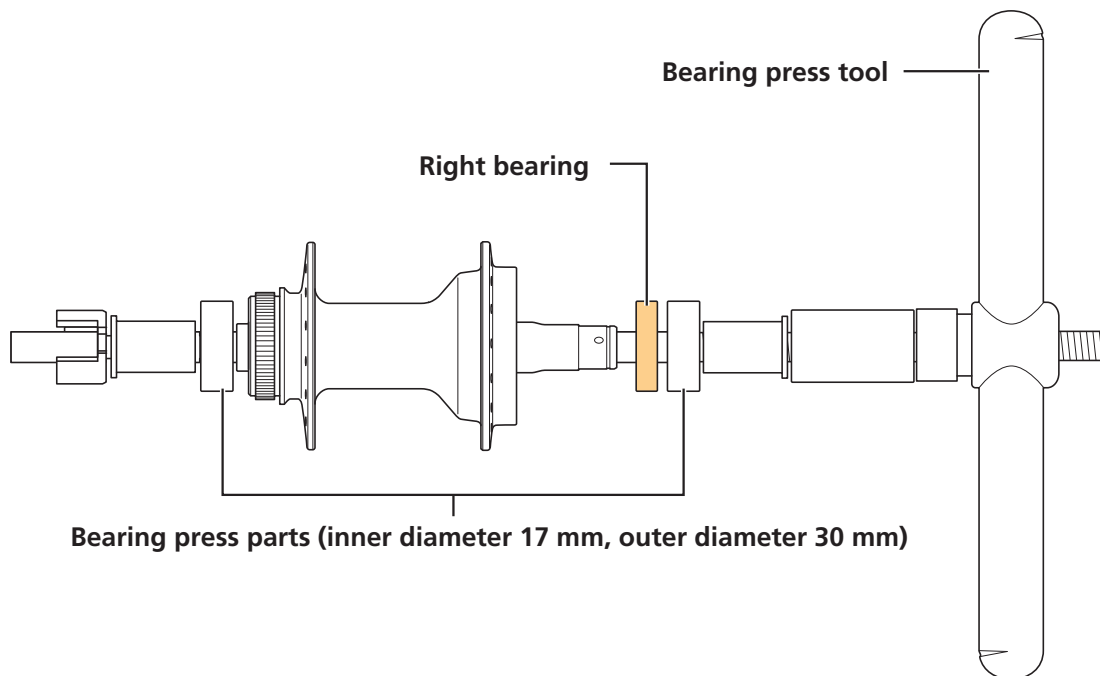

- (3) Turn the handle of the bearing press tool, and insert the right bearing as far as it will go.

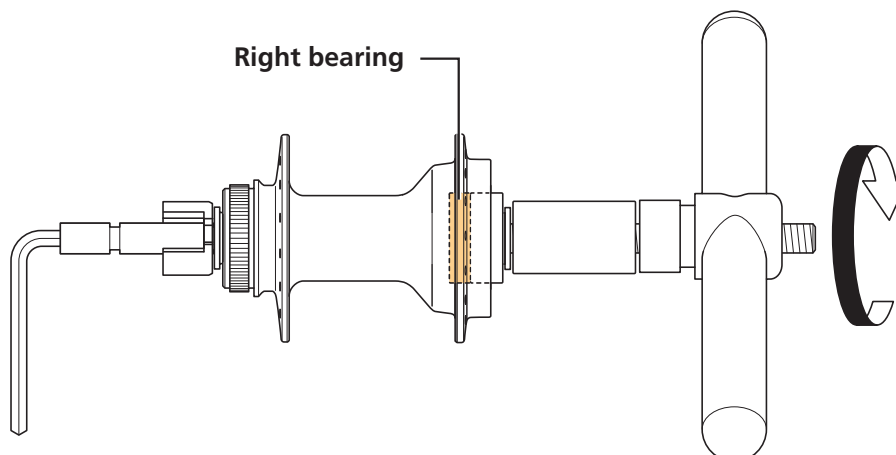

NOTICE

- The bearing press part should touch both the outer ring and inner ring of the bearing.

4. Install the seal ring and left hand lock nut.

When installing the left hand lock nut, secure the hub axle with a hexagon wrench.

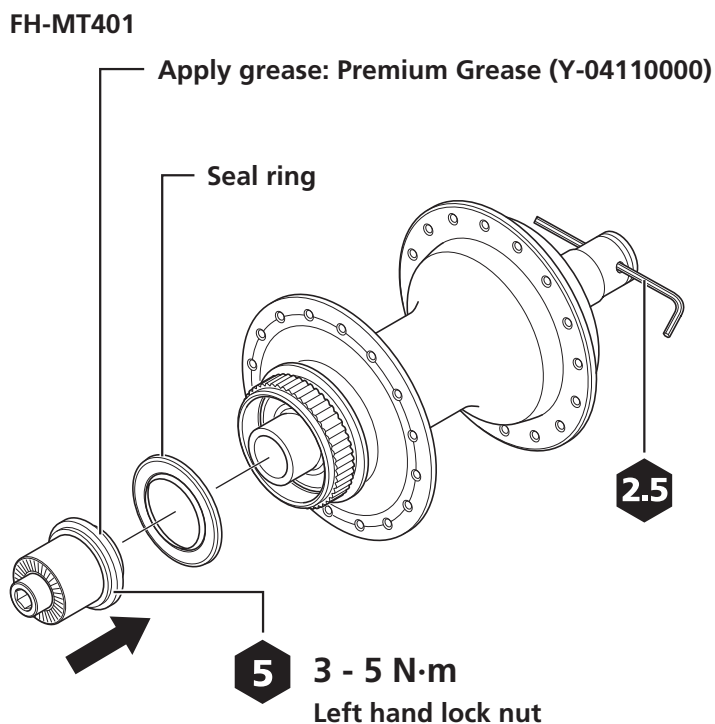
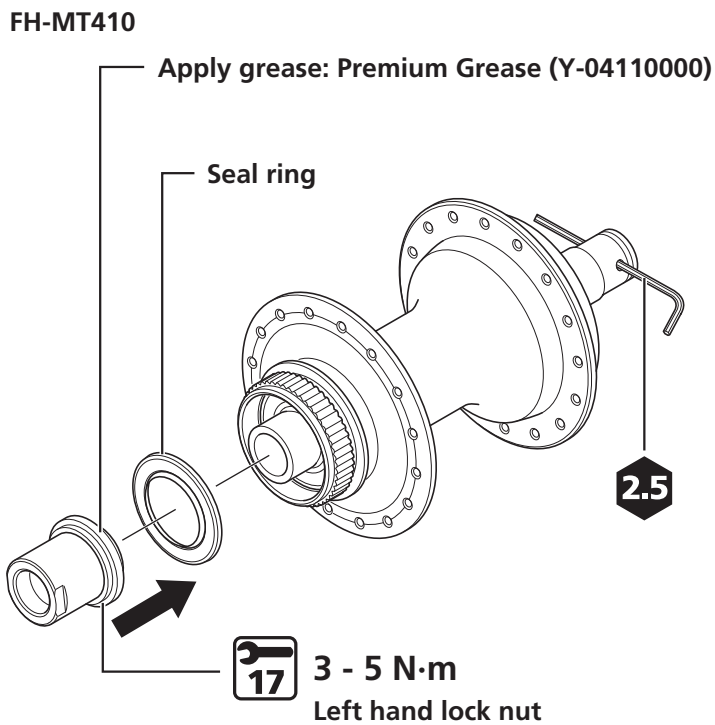

5. Apply grease to the ratchet part, freehub body unit, and right cap.

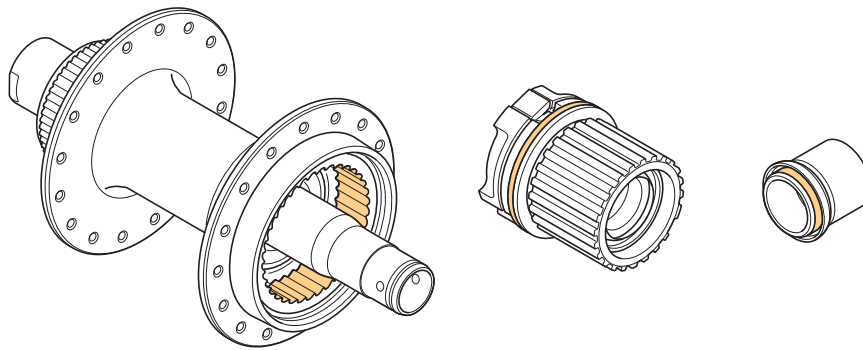

6. Install the bush, freehub body unit, and right cap to the hub.

Be sure to push the right cap until it clicks.

After installing the freehub body unit, check that the lip of the seal ring is not facing the wrong way.

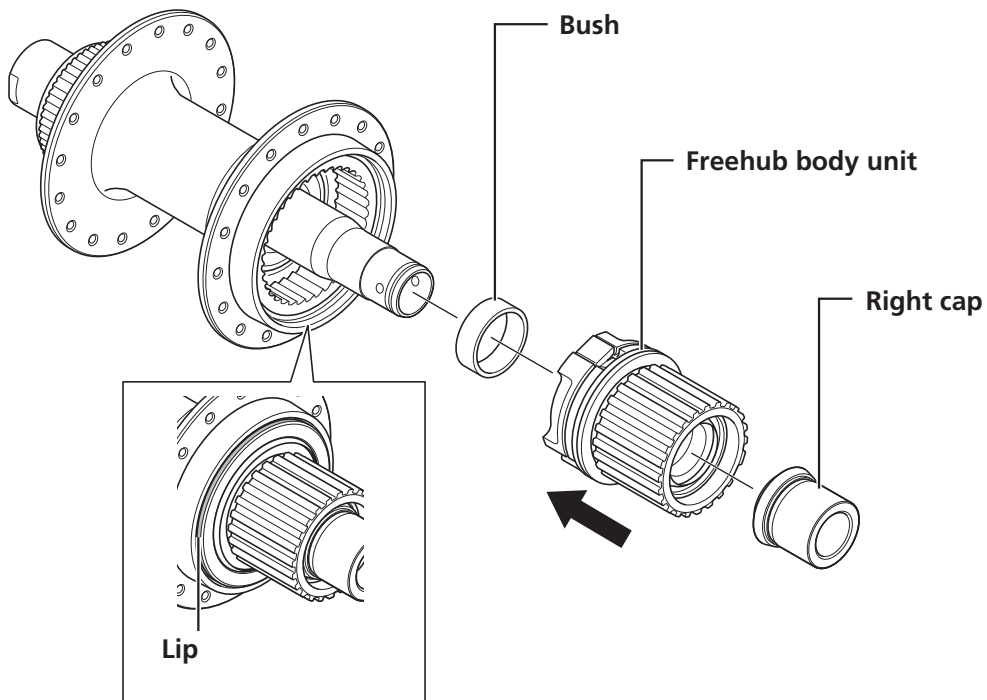

NOTICE

- The correct position for the dust cover is where it is hidden in the freewheel body, as shown in illustration [1]. If the dust cover is in the position shown in illustration [2], repeat the assembly process from the beginning.

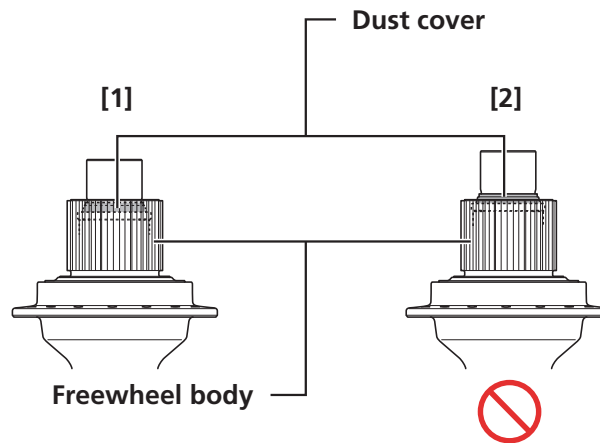

7. Install the outer seal cap.

Make sure that the outer seal cap is installed in the correct direction.

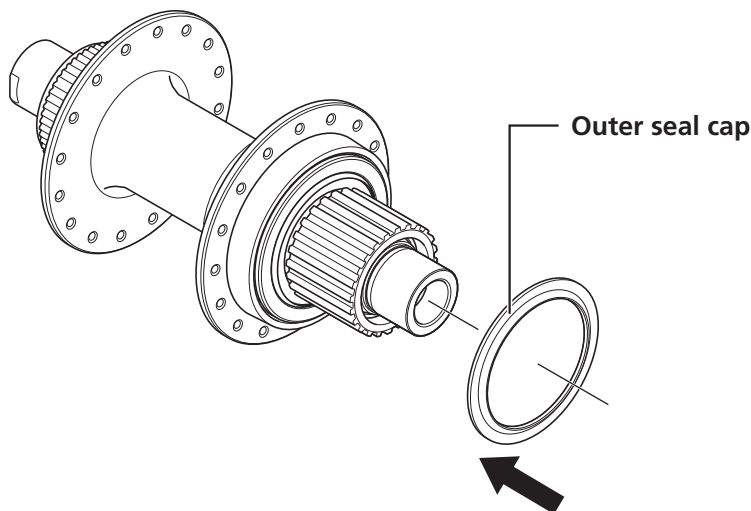

8. Check that the bearing is completely installed using the following procedures.

- (1) Hold both sides of the hub axle and move the hub main body in the axle direction to confirm that there is no gap. If there is a gap, perform step 2 to press-fit again. If there is still a gap, perform step 3 again.
- (2) Hold both sides of the hub axle and rotate the hub main body to confirm that it rotates smoothly. If it is not smooth, gently tap it with a hammer to loosen it as when performing disassembly. When loosening, loosen the right bearing first.

Replacing the freehub body unit

Refer to “Disassembly” and “Assembly” when replacing the freehub body unit.

The procedure from step 1 in “Disassembly” is unnecessary, since the hub axle does not need to be removed.

SHIMANO

SHIMANO NORTH AMERICA BICYCLE, INC.

One Holland, Irvine, California 92618, U.S.A. Phone: +1-949-951-5003

SHIMANO EUROPE B.V.

High Tech Campus 92, 5656 AG Eindhoven, The Netherlands Phone: +31-402-612222

SHIMANO INC.

3-77 Oimatsu-cho, Sakai-ku, Sakai City, Osaka 590-8577, Japan

Please note: specifications are subject to change for improvement without notice. (English)

© Jan. 2020 by SHIMANO INC. ITP