

Dealer's Manual

ROAD	MTB	Trekking
City Touring/ Comfort Bike	URBAN SPORT	E-BIKE

Shifting Lever

XTR

SL-M9100

DEORE XT

SL-M8100

SL-M8130

SLX

SL-M7100

Seat Post Lever

SL-MT800

Contents

IMPORTANT NOTICE	3
TO ENSURE SAFETY	4
List of tools to be used	7
Installation/removal	8
Installing the shifting lever.....	8
Installing the seat post lever	11
Adjustment	17
Adjusting the stopped lever position (MONO lever)	17
Maintenance	20
Replacing the inner cable	20
Replacing the shifting lever unit.....	24
Replacing the lever pad (shifting lever).....	28



IMPORTANT NOTICE

- This dealer's manual is intended primarily for use by professional bicycle mechanics.
Users who are not professionally trained for bicycle assembly should not attempt to install the components themselves using the dealer's manuals.
If any part of the information on the manual is unclear to you, do not proceed with the installation. Instead, contact your place of purchase or a distributor for assistance.
- Make sure to read all manuals included with the product.
- Do not disassemble or modify the product other than as stated in the information contained in this dealer's manual.
- All manuals and technical documents are accessible online at <https://si.shimano.com> .
- For consumers who do not have easy access to the internet, please contact a SHIMANO distributor or any of the SHIMANO offices to obtain a hardcopy of the User's Manual.
- Please observe the appropriate rules and regulations of the country, state or region in which you conduct your business as a dealer.

For safety, be sure to read this dealer's manual thoroughly before use, and follow it for correct use.

The following instructions must be observed at all times in order to prevent personal injury and physical damage to equipment and surroundings.

The instructions are classified according to the degree of danger or damage which may occur if the product is used incorrectly.

 DANGER	Failure to follow the instructions will result in death or serious injury.
 WARNING	Failure to follow the instructions could result in death or serious injury.
 CAUTION	Failure to follow the instructions could cause personal injury or physical damage to equipment and surroundings.

TO ENSURE SAFETY

WARNING

- Be sure to follow the instructions provided in the manuals when installing the product.
It is recommended that you use SHIMANO genuine parts. If bolts and nuts become loose or damaged, the bicycle may suddenly fall over, result in a serious injury.
-  Wear approved eye protection while performing maintenance tasks such as replacing components.

NOTICE

Be sure to also inform users of the following:

- Be sure to keep turning the crank arm during the shifting lever operation.
- If gear shifting operation does not feel smooth, consult the place of purchase for assistance.
- Products are not guaranteed against natural wear and deterioration from normal use and aging.
- For maximum performance we highly recommend SHIMANO lubricants and maintenance products.

For installation to the bicycle, and maintenance:

- Grease with SIS SP41 grease (Y04180000) the inner cable and the sliding portions of the outer casing before use to ensure that they slide properly.
- Use an OT-SP41 cable and a cable guide (SM-SP17 / SP18) for smooth operation.
- A special grease is used for the gear shifting cable. Do not use Premium Grease or other types of grease, otherwise, they may cause deterioration in gear shifting performance.
- Use an outer casing which still has some length to spare even when the handlebars are turned all the way to either side. Furthermore, check that the shifting lever does not touch the bicycle frame when the handlebars are turned all the way.
- If gear shifting adjustments cannot be carried out, check the alignment of the dropout and check if the cable is lubricated or if the outer casing is too long or too short.
- List of cables used

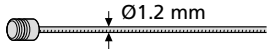
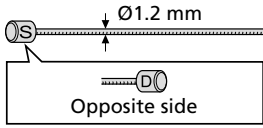
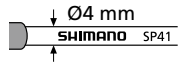
	Designated inner cable	Recommended outer casing
SL-M9100		SP41 outer casing
SL-M8100 SL-M8130 SL-M7100 SL-MT800		

* Refer to the list of recommended outer caps.

* Do not let dust adhere on the inner cable. If the grease on the inner cable is wiped off, the application of SIS SP41 grease (Y04180000) is recommended.

- List of recommended outer caps (SL-M9100 / SL-M8100 / SL-M8130 / SL-M7100)

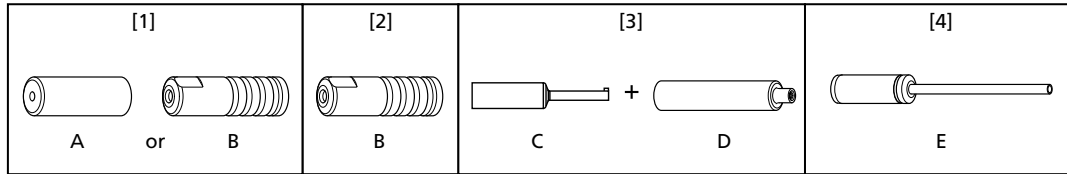
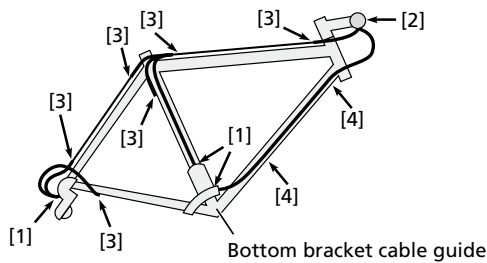

Type of outer cap		Remarks
A	Sealed outer cap (aluminum type)	FD / RD side Recommended when the outer casing moves to a large degree, such as in bicycles with suspension frames
B	Sealed outer cap (resin type)	Shifting lever / FD / RD side
C	Sealed outer cap with tongue	Outer casing holder on frame side
D	Rubber shield	
E	Outer cap with long tongue	Recommended for bikes with internal cable routing where there is not a straight angle and/or the inner cable contacts the frame material where it enters the frame

- The recommended outer cap of SL-MT800 is a sealed outer cap (resin type) on both the lever side and seat post side.
- Before using SL-M8130 and other LINKGLIDE products, check the combinations listed in the compatibility information (<https://productinfo.shimano.com/#/com>). Other products cannot be used because the specifications do not match.









11-speed specifications: <https://productinfo.shimano.com/#/com?cid=C-432&acid=C-435>

10-speed specifications: <https://productinfo.shimano.com/#/com?cid=C-432&acid=C-436>

The actual product may differ from the illustration because this manual is intended mainly to explain the procedures for using the product.

List of tools to be used

The following tools are needed for installation/removal, adjustment, and maintenance purposes.

Tool	
	2 mm hexagon wrench
	2.5 mm hexagon wrench
	3 mm hexagon wrench
	4 mm hexagon wrench
	Cross head screwdriver [#0]
	Cross head screwdriver [#1]
	Cross head screwdriver [#2]
	Slotted screwdriver (width 4.5 - 5.5 mm)
	TL-CT12

Installation/removal

Installing the shifting lever

When installing parts onto a carbon frame / handlebar, confirm the recommended tightening torque with the carbon frame or handlebar manufacturer. This will prevent damage to the frame/handlebar due to over-torquing or inadequate securing of the components.

Standard type

1. Tighten the mounting screws.

Use a handlebar grip with a maximum outer diameter of $\varnothing 32$ mm or less ($\varnothing 36$ mm or less for SL-M7100).

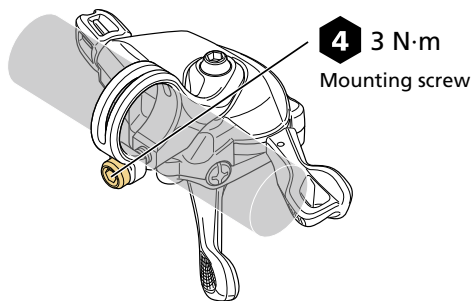

NOTICE

- Check that the brake and gear shifting operations are not obstructed.

I-SPEC EV

For information on brake levers that can be installed, check the compatibility information (<https://productinfo.shimano.com>).

Installation/removal

Installing the shifting lever

1. Open the clamp band of the brake lever.

- (1) Loosen the mounting screw.
- (2) Press the recessed area of the clamp band with a tool such as a 2 mm hexagon wrench to disengage the safety latch.

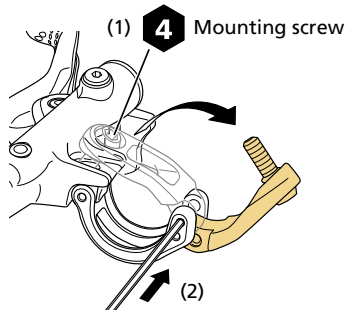

2. Temporarily attach the shifting lever to the clamp band.

Temporarily install with the unit position adjustment bolt as shown in the figure. Make sure to firmly install the unit position adjustment nut to the clamp band.

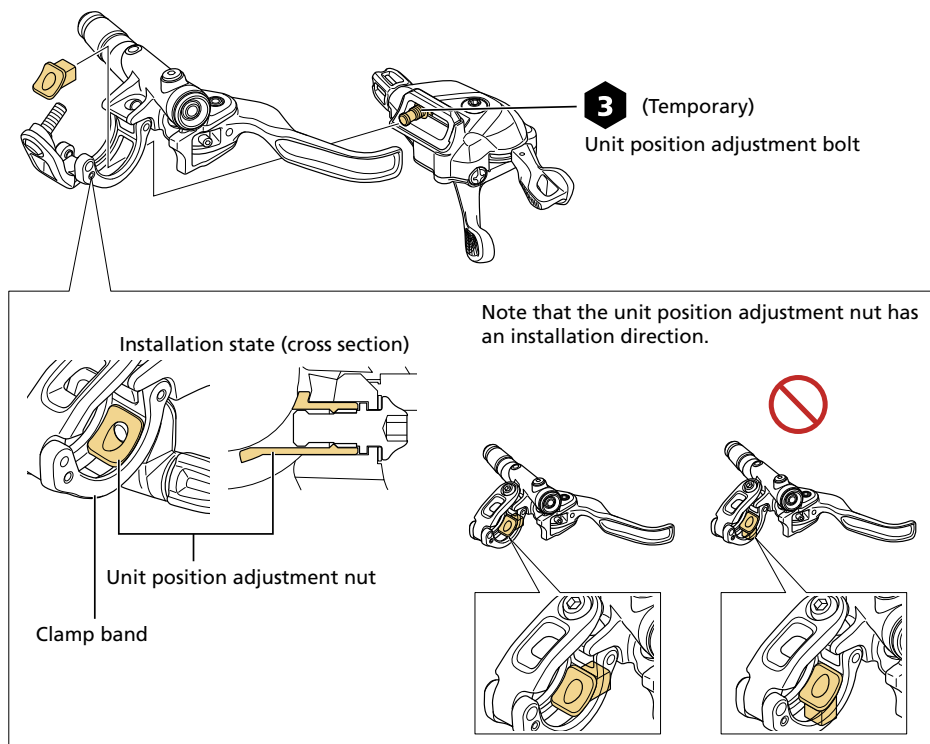

Installation/removal

Installing the shifting lever

- 3. Pull an O-ring to the clamp band side as shown in the figure.**

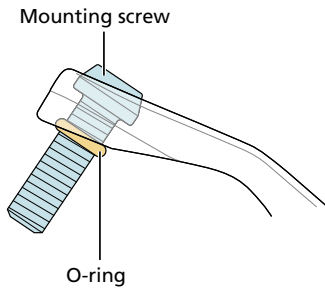

- 4. Attach the brake lever to the handlebar.**

Secure the lever using the mounting screw.

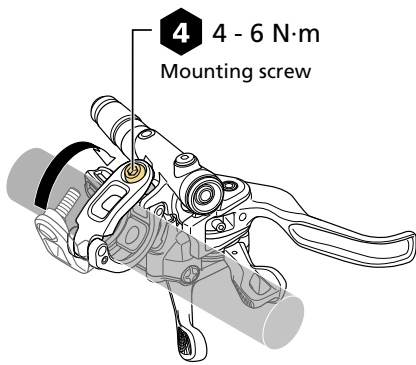

5. Adjust the position of the shifting lever.

Adjust the shifting lever by sliding it vertically or horizontally.

If it is difficult to slide the shifting lever, loosen the unit position adjustment bolt.

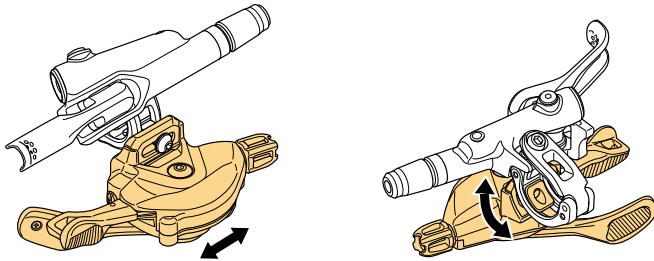

TECH TIPS

- To remove it, loosen the unit position adjustment bolt while pulling the main body of the shifting lever away from the brake lever. Since the thread of the unit position adjustment bolt is cut off midway to prevent detachment, it is necessary to pull the main body of the shifting lever away from the brake lever.

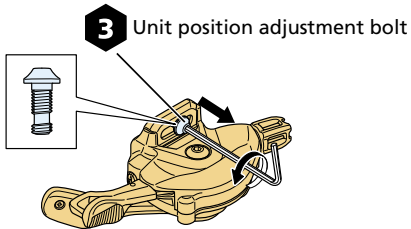

6. Tighten the unit position adjustment bolt.

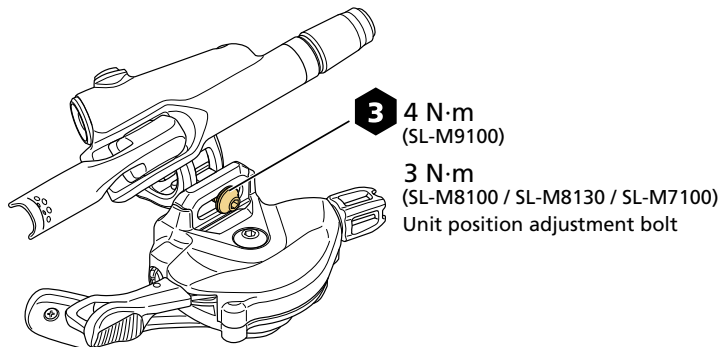

Installing the seat post lever

For information on brake levers that can be installed, check the compatibility information (

<https://productinfo.shimano.com>).

1. Open the clamp band of the brake lever.

- (1) Loosen the mounting screw.
- (2) Press the recessed area of the clamp band with a tool such as a 2 mm hexagon wrench to disengage the safety latch.

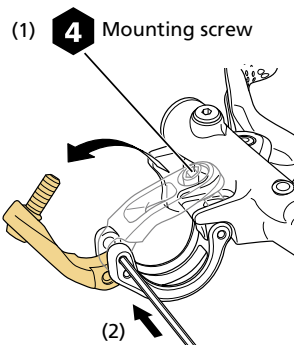

2. Temporarily attach the seat post lever to the clamp band.

Temporarily install with the unit position adjustment bolt as shown in the figure. Make sure to firmly install the unit position adjustment nut to the clamp band.

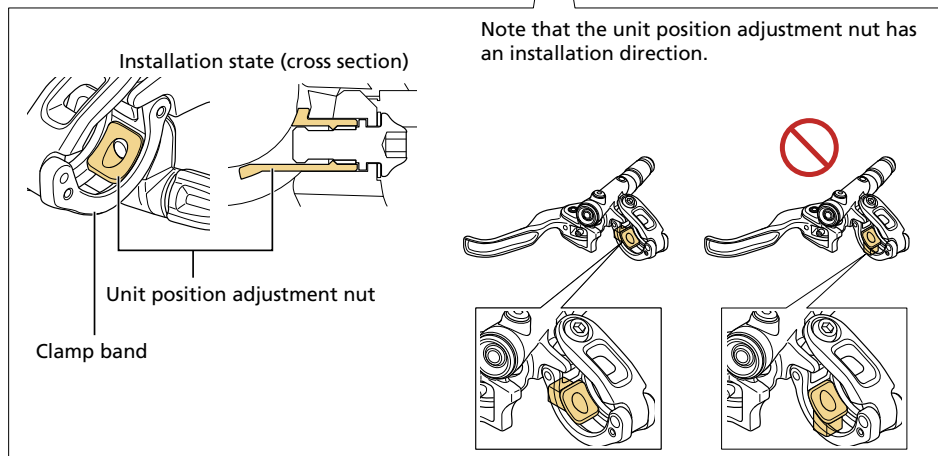
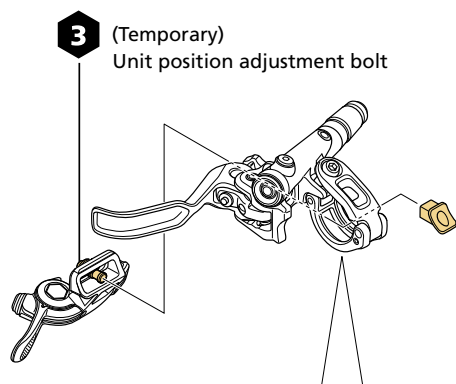

Installation/removal

Installing the seat post lever

3. Pull an O-ring to the clamp band side as shown in the figure.

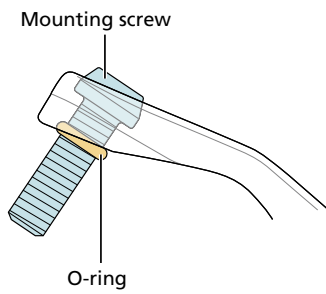

4. Attach the brake lever to the handlebar.

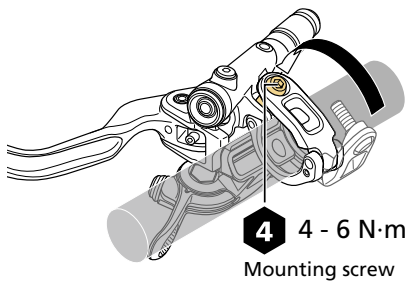

5. Adjust the position of the seat post lever.

Adjust the seat post lever by sliding it vertically or horizontally.

If it is difficult to slide the shifting lever, loosen the unit position adjustment bolt.

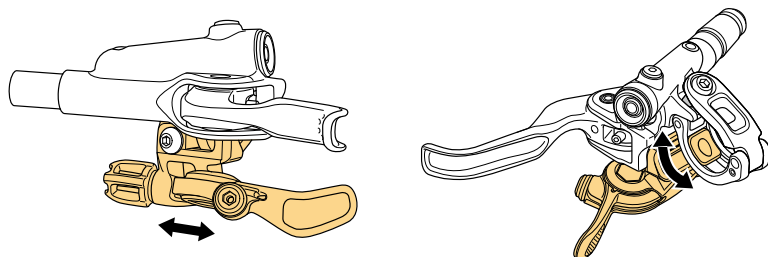

TECH TIPS

- To remove it, loosen the unit position adjustment bolt while pulling the main body of the seat post lever away from the brake lever. Since the thread of the unit position adjustment bolt is cut off midway to prevent detachment, it is necessary to pull the main body of the seat post lever away from the brake lever.

3 Unit position adjustment bolt

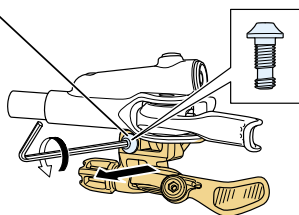

6. Tighten the unit position adjustment bolt.

3 4 N·m

Unit position adjustment bolt

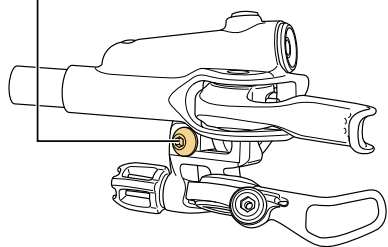

Installation/removal

Installing the seat post lever

7. Set the inner cable.

Pass the cable through the cable fixing groove located above the cable fixing screw.

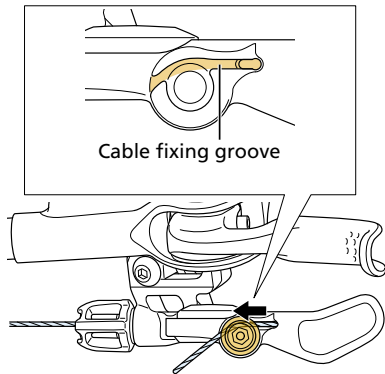

8. Tighten the cable fixing screw.

While pulling the inner cable, tighten the cable fixing screw.

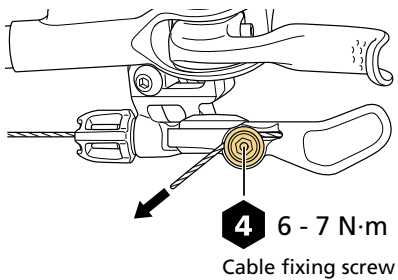

9. Cut the inner cable so that the protruding length is 12 - 15 mm.

Use TL-CT12 to cut the cable.

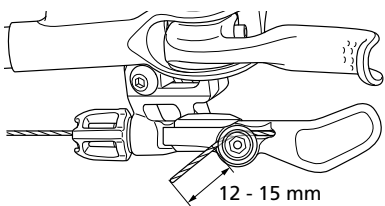

10. Install the inner end cap.

Use TL-CT12 to crimp the inner end cap.

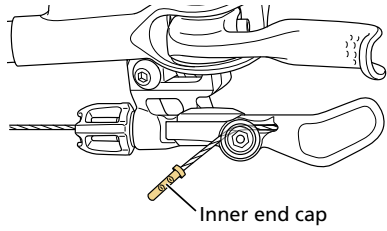

Adjustment

Adjusting the stopped lever position (MONO lever)

The stopped lever position can be adjusted. The lever will remain in the adjusted position after a lever operation. An additional lever operation will return the lever to its initial position.

Adjustment

Adjusting the stopped lever position (MONO lever)

⚠ CAUTION

- Adjusting the stopped lever position must only be done after returning the lever to its initial position. If the adjuster is moved during lever operation, the lever may be damaged.

SL-M9100

1. Turn while pressing the adjuster.

Turn with a slotted screwdriver (4.5 - 5.5 mm in width).

Make sure that the pressed adjuster returns to its original height after the adjustment is finished.

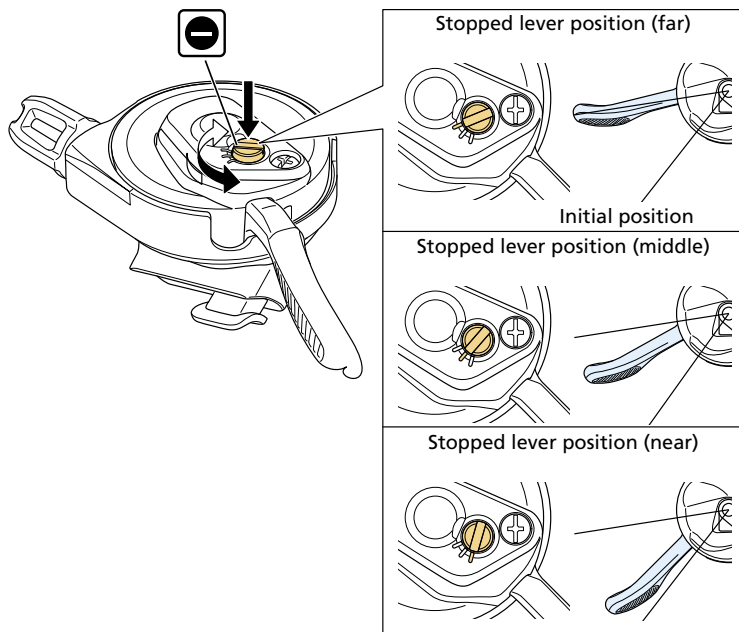

Adjustment

Adjusting the stopped lever position (MONO lever)

SL-M8100 / SL-M7100

1. Turn the adjuster while pushing it towards the lever body.

The stopped lever position changes based on the position of the recessed area of the adjuster.

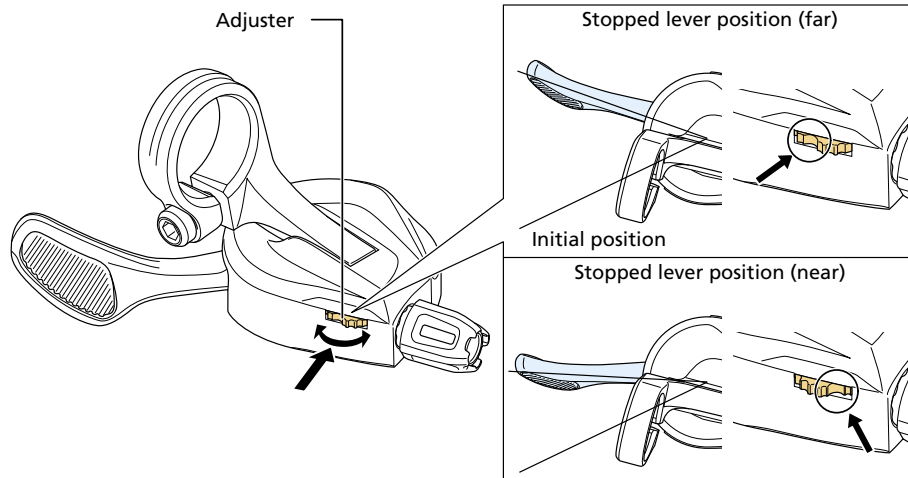

Maintenance

Replacing the inner cable

Before beginning the replacement tasks, loosen the cable fixing screws (nuts) of the front derailleur, rear derailleur, and seat post.



Shifting lever

1. Set the shifting lever in its initial position.

Operate the release lever 11 or more times for a 12-speed and 10 or more times for an 11-speed.

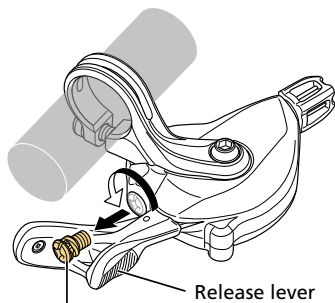
2. Remove the inner hole cap.



 /  (SL-M9100 / SL-M8100 / SL-M8130)

 (SL-M7100)

Inner hole cap

Maintenance

Replacing the inner cable

3. Replace the inner cable and install an inner hole cap.

Turn and stop the inner hole cap at the position shown in the figure. If you force it to turn, it may damage the screw thread on the cap.

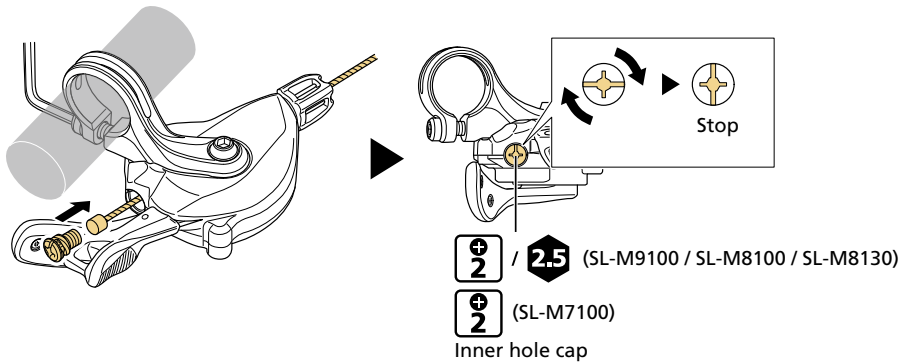

Shifting lever (MONO lever)

1. Set the lever in its initial position.

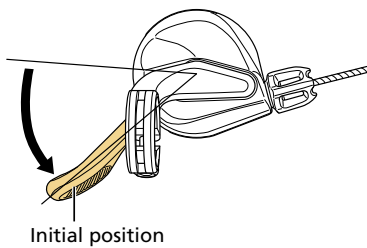

2. Loosen the cover mounting screw.

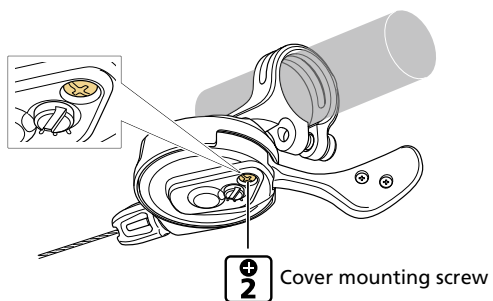

Maintenance

Replacing the inner cable

3. Slide the cover and remove the inner cable.

Do not remove the cover completely. Remove the inner cable from the gap.

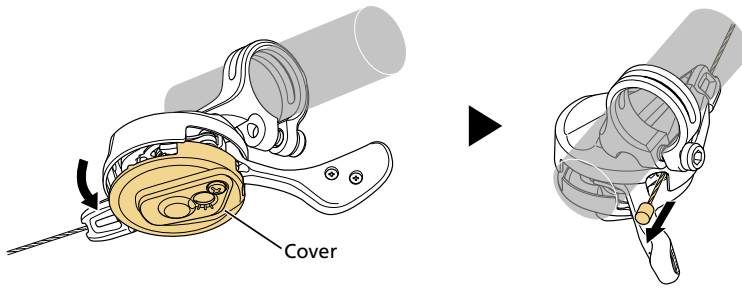

NOTICE

- Pulling on the cover forcibly may cause damage to the drop prevention tab.

4. Install the inner cable.

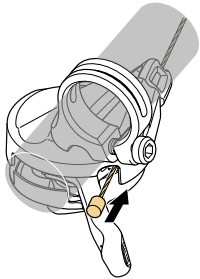

5. Install the cover in the reverse order of disassembly.

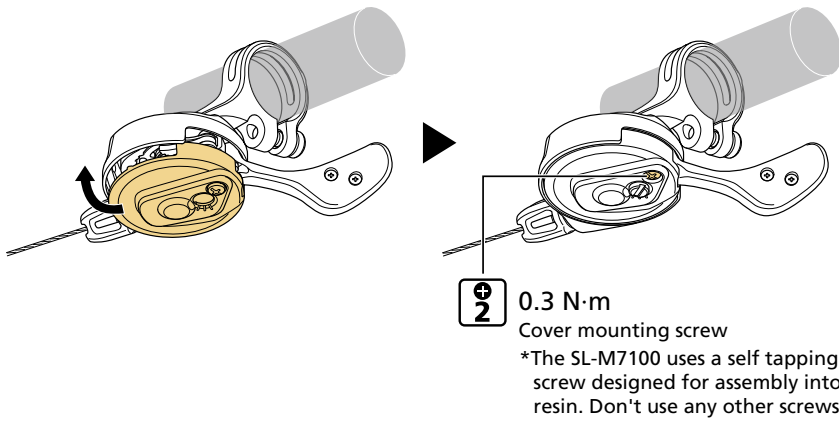

Seat post lever

1. Separate the inner end cap.

Cut the inner cable with TL-CT12.

2. Loosen the cable fixing screw and remove the inner cable.

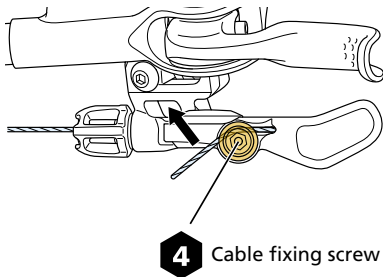

3. Set the inner cable.

Pass the cable through the cable fixing groove located above the cable fixing screw.

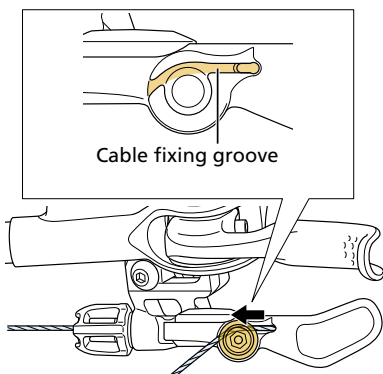

Maintenance

Replacing the shifting lever unit

4. Tighten the cable fixing screw.

While pulling the inner cable, tighten the cable fixing screw.

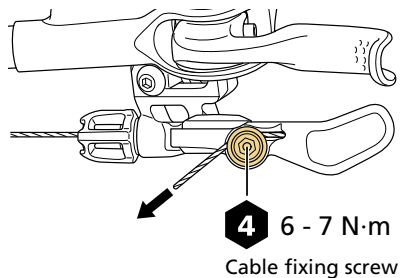

5. Cut the inner cable so that the protruding length is 12 - 15 mm.

Use TL-CT12 to cut the cable.

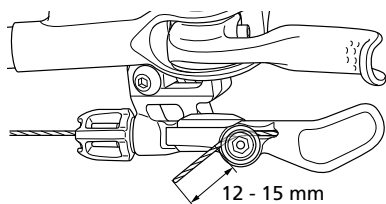

6. Install the inner end cap.

Use TL-CT12 to crimp the inner end cap.

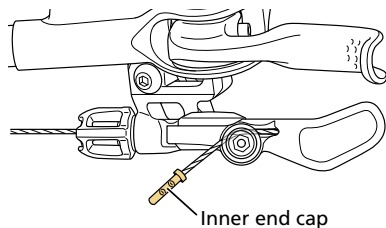

Replacing the shifting lever unit

Disassembly and assembly should only be conducted when replacing the shifting lever unit.

* The MONO lever unit cannot be replaced.



Maintenance

Replacing the shifting lever unit

1. Remove the inner cable.

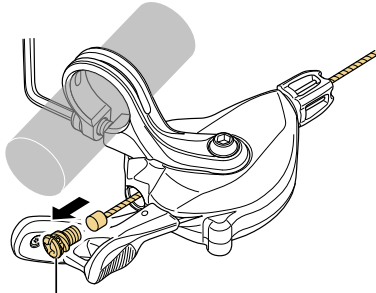
Follow the same instructions used in the replacement procedure.



 /  (SL-M9100 / SL-M8100 / SL-M8130)

 (SL-M7100)

Inner hole cap

2. Remove the cable adjustment barrel.

Loosen by hand and remove the cable adjustment barrel.

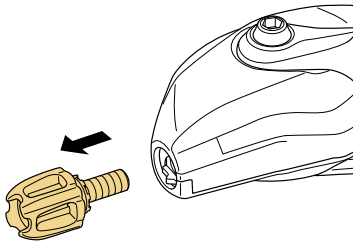

Maintenance

Replacing the shifting lever unit

3. Remove the unit fixing screw.

Standard type

- 4** 2.5 N·m (During tightening)
(SL-M9100)
- 3** 2.5 N·m (During tightening)
(SL-M8100 / SL-M8130 / SL-M7100)
Unit fixing screw

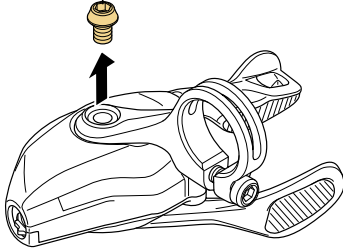

I-SPEC EV

- 3** 2.5 N·m (During tightening)
Unit fixing screw

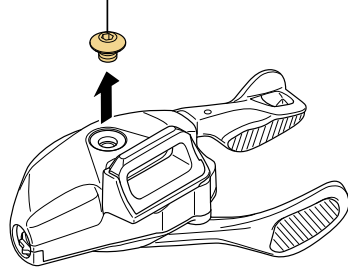

Maintenance

Replacing the shifting lever unit

4. Remove the shifting lever unit.

- (1) Remove the three mounting screws.
- (2) Remove the cover.

* Perform the installation of the shifting lever unit in the reverse order from the removal procedure.

SL-M9100 / SL-M8100 / SL-M8130

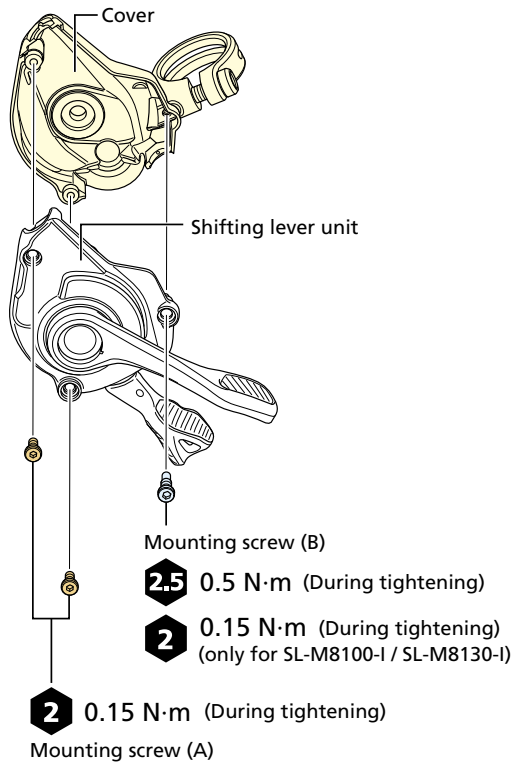

NOTICE

- Only for SL-M8100-I / SL-M8130-I does a mounting screw (B) become a self tapping screw.

SL-M7100

Maintenance

Replacing the lever pad (shifting lever)

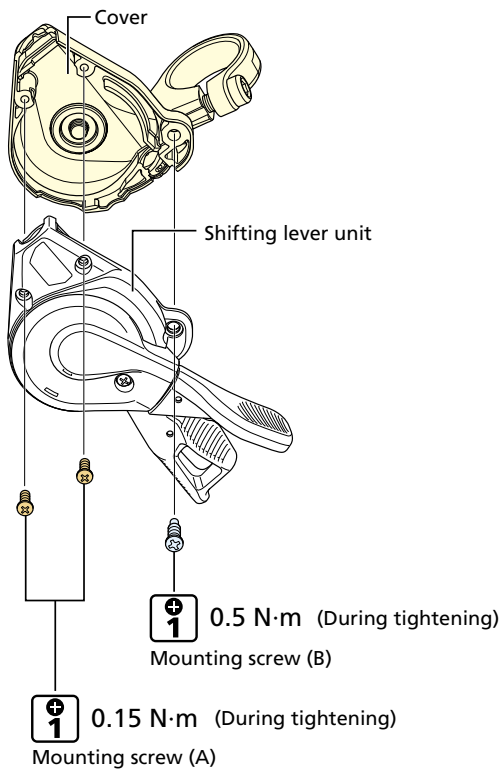

Replacing the lever pad (shifting lever)

There is no lever pad for SL-M7100.

Maintenance

Replacing the lever pad (shifting lever)

NOTICE

- Be sure to use the specified screwdriver size when installing/removing the pad mounting screws. If a screwdriver size other than the one specified is used, the pad mounting screws may be damaged.

SL-M9100

1. Remove the pad mounting screws.

Remove the screws in two locations.

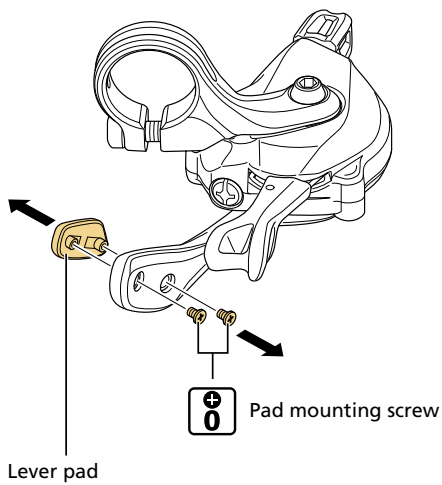

Maintenance

Replacing the lever pad (shifting lever)

2. Replace the lever pad, then tighten the pad mounting screws.

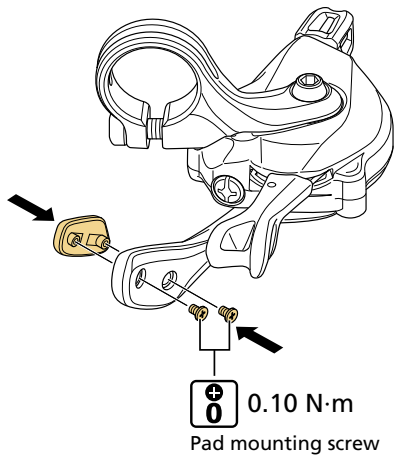

SL-M8100 / SL-M8130

1. Remove lever pad.

Use a 2 mm hexagon wrench on the three holes on the inner side of the lever to push out the lever pad.

2. Install the new lever pad.

Insert the protrusions (three locations) of the lever pad into the holes in the lever.

After it is inserted, check that it is firmly attached.

