

Dealer's Manual

ROAD	GRAVEL	MTB
E-BIKE	LIFESTYLE	GENERAL

SPD Pedals

XTR

PD-M9100

PD-M9120

DEORE XT

PD-M8100

PD-M8120

Non-Series

PD-ME700

Contents

IMPORTANT NOTICE.....	3
TO ENSURE SAFETY.....	4
List of tools to be used	7
Installation/removal	8
Installing cleats.....	8
Installing to the crank.....	11
Maintenance.....	13
Adjusting the cleat holding force of the pedals	13
Adjusting axle bearings	13
Replacing body covers	18
Installing/removing the reflectors.....	18



IMPORTANT NOTICE

- This dealer's manual is intended primarily for use by professional bicycle mechanics. Users who are not professionally trained for bicycle assembly should not attempt to install the components themselves using the dealer's manuals. If any part of the information on the manual is unclear to you, do not proceed with the installation. Instead, contact your place of purchase or a distributor for assistance.
- Make sure to read all manuals included with each product.
- Do not disassemble or modify the product other than as stated in the information contained in this dealer's manual.
- All manuals and technical documents are accessible online at <https://si.shimano.com> .
- For consumers who do not have easy access to the internet, please contact a SHIMANO distributor or any of the SHIMANO offices to obtain a hardcopy of the user's manual.
- Please observe the appropriate rules and regulations of the country, state or region in which you conduct your business as a dealer.

For safety, be sure to read this dealer's manual thoroughly before use, and follow it for correct use.

The following instructions must be observed at all times in order to prevent personal injury and physical damage to equipment and surroundings.

The instructions are classified according to the degree of danger or damage which may occur if the product is used incorrectly.

 DANGER	Failure to follow the instructions will result in death or serious injury.
 WARNING	Failure to follow the instructions could result in death or serious injury.
 CAUTION	Failure to follow the instructions could cause personal injury or physical damage to equipment and surroundings.

TO ENSURE SAFETY

WARNING

- Be sure to follow the instructions provided in the manuals when installing the product.
Only use SHIMANO genuine parts. If a component or replacement part is incorrectly assembled or adjusted, it can lead to component failure and cause the rider to lose control and crash.
-  Wear approved eye protection while performing maintenance tasks such as replacing components.

Be sure to also inform users of the following:

- In order to ensure child safety for children using this product, children should be given instruction on the correct use after both guardians and children have fully understood the following information. Failure to follow the provided instructions may lead to serious injury.
- Before attempting to ride with these pedals and cleats (shoes), make sure you understand the operation of the engagement and release mechanism. SPD pedals are designed to be released only when intended. They are not designed to be released automatically when you have fallen off the bicycle.
- Before attempting to ride with these pedals and cleats, apply the brakes, then place one foot on the ground and practice engaging and releasing each cleat from its pedal until you can do so naturally and with minimal effort.
- Ride on level ground first until you become accustomed to engaging and releasing your cleats from the pedals.
- Before riding, adjust the cleat holding force of the pedals to your liking. If the cleat holding force of the pedals is low, the cleats may become accidentally released and you may lose balance and fall off the bicycle. If the cleat holding force of the pedals is high, the cleats cannot be easily released.
- When riding at low speed or when there is a possibility that you might need to stop riding (for example, when doing a U-turn, nearing an intersection, riding uphill, or turning a blind curve), release your cleats from the pedals beforehand so that you can quickly put your feet onto the ground at any time.
- Use a lighter cleat holding force for attaching the pedal cleats when riding in adverse conditions.
- Keep cleats and bindings out of dirt and debris to ensure proper engagement and release.
- Remember to check the cleats periodically for wear. When the cleats are worn, replace them, and adjust the cleat holding force before riding and after replacing the pedal cleats.
- Use only SPD shoes with this product. Other types of shoes may not release from the pedals, or may release unexpectedly.
- Use only SHIMANO cleats (SM-SH51 / SM-SH56) and make sure that the mounting screws are tightened securely to the shoes. Failure to securely tighten the screws may result in a fall in which the cleats do not release.

If the warnings above are not followed, your shoes may not come out of the

pedals when you intend or they may come out unexpectedly or accidentally, and severe injury may result.

- Be sure to attach reflectors to the bicycle when traveling on roads. Reflectors are sold separately for models that do not come with reflectors equipped as standard. For information on compatible reflectors, contact the place of purchase or a distributor.
- Do not continue riding the bicycle if the reflectors are dirty or damaged. Otherwise, it becomes more difficult for oncoming vehicles to see you.

NOTICE













Be sure to also inform users of the following:

- Check that there is no excess play or looseness in any fastening sections before riding the bicycle.
- Check that there is no excess play or looseness in the cleats or spacers before riding the bicycle.
- If pedaling performance does not feel normal, contact your place of purchase.
- If you experience any trouble with the rotating parts of the pedal, the pedal may require adjustment. Consult your place of purchase or a distributor.
- Be sure to retighten the crank arms and pedals at periodic intervals at the place of purchase or a distributor.
- Products are not guaranteed against natural wear and deterioration from normal use and aging.
- For maximum performance we highly recommend SHIMANO lubricants and maintenance products.

The actual product may differ from the illustration because this manual is intended mainly to explain the procedures for using the product.

List of tools to be used

The following tools are needed for installation/removal, adjustment, and maintenance purposes.

Tool	
	2.5 mm hexagon wrench
	3 mm hexagon wrench
	4 mm hexagon wrench
	8 mm hexagon wrench
	7 mm spanner
	8 mm spanner
	10 mm spanner
	15 mm spanner
	17 mm spanner
	TL-PD40
	Hexalobular [#10]
	Cross head screwdriver
	Cross head screwdriver [#2]

Installation/removal

Installing cleats

Types of cleats

The release mode varies depending on the type of cleats being used.

Type of cleats being used		Release mode
Single release mode cleats	SM-SH51 (black)	Only release when the heel is moved outward.
Multiple release mode cleats	SM-SH56 (silver, gold)	Can be released by twisting in any direction.

Temporarily installing cleats

1. Remove the rubber cover for the cleat mounting holes.

* This step may not be necessary depending on the type of shoe.

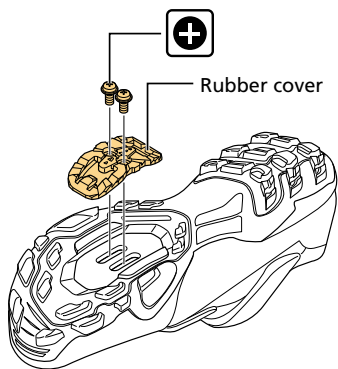

2. Set the cleat nut.

Remove the insole, then set along the elongated holes.

* This step may not be necessary depending on the type of shoe.

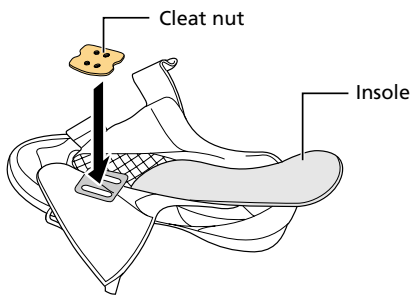

3. Temporarily install the cleats.

Use the cleat mounting screws to temporarily tighten each part in the order shown in the figure. The cleats are not specific to the left or right pedals. They can be used interchangeably.

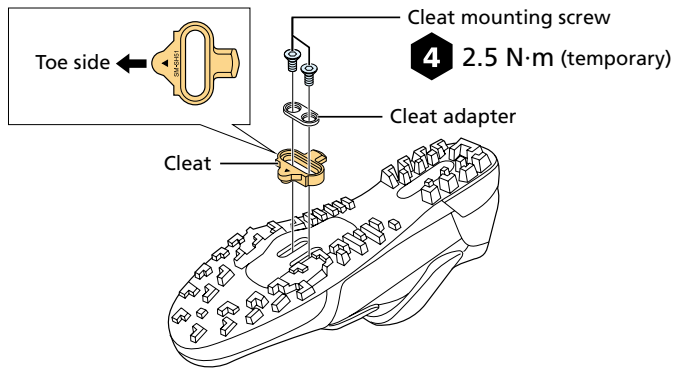

TECH TIPS

- Use cleat spacers in the following cases. When using spacers, use only one per SPD compatible shoe.
 - If you are riding in conditions in which dirt or debris build up inhibits smooth engagement of the shoe and pedal.
 - If the tread on the sole of the shoe causes interference and inhibits smooth engagement of the shoe and pedal.
 - If the cleat spacer is only compatible with SHIMANO cleats (SM-SH51 / SM-SH56).

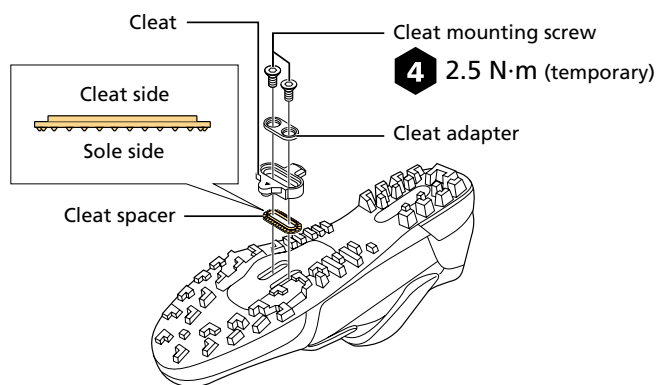

Adjusting and securing cleat positions

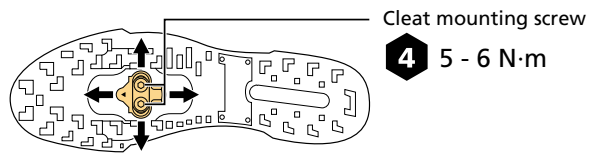

1. Confirm the optimal cleat positions.

Repeatedly adjust and confirm for each foot to determine the optimal cleat positions.

* The cleat has an adjustment range of 20 mm front to back and 5 mm right to left.

2. Securely tighten the cleats.

Tighten the cleat mounting screws using the specified torque.

Installing waterproof seals

1. If your SHIMANO shoes came packaged with waterproof seals, attach the waterproof seals after securely tightening the cleats.

Remove the insole and attach the waterproof seal.

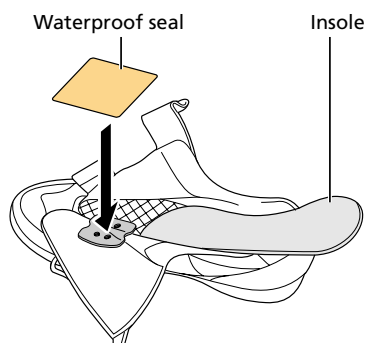

Installing to the crank

1. Apply a small amount of grease to the threads.

2. Install the pedals.

The right pedal has a right-hand thread; the left pedal has a left-hand thread.

PD-M9100 / PD-M9120 /
PD-M8100 / PD-M8120

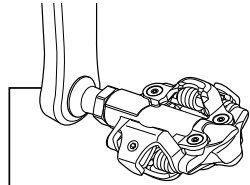

8 35 - 55 N·m

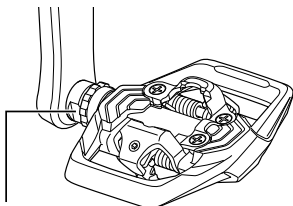

PD-ME700



15 35 - 55 N·m

NOTICE

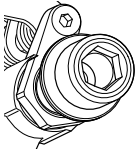
- For the PD-M9100 / PD-M9120 / PD-M8100 / PD-M8120, pay attention to the difference between the left and right pedals.

Right pedal	Left pedal
 No grooves in thread	 Grooves in thread
Right-hand thread	Left-hand thread

- For the PD-ME700, pay attention to the left (L) and right (R) markings.

Maintenance

Adjusting the cleat holding force of the pedals

1. Turn the adjustment screw and adjust to the optimal cleat holding force when releasing the cleats from the bindings.

- Turning the adjustment screw clockwise increases the cleat holding force, and turning it counterclockwise decreases it.
- Clicking the adjustment screw once changes the tension one step. There are four clicks per turn.
- The adjustment screw is located at the rear of each binding, resulting in four positions in total.
- Equalize the cleat holding forces at all positions by checking the adjustment plate position and counting the number of turns of the adjustment screws.

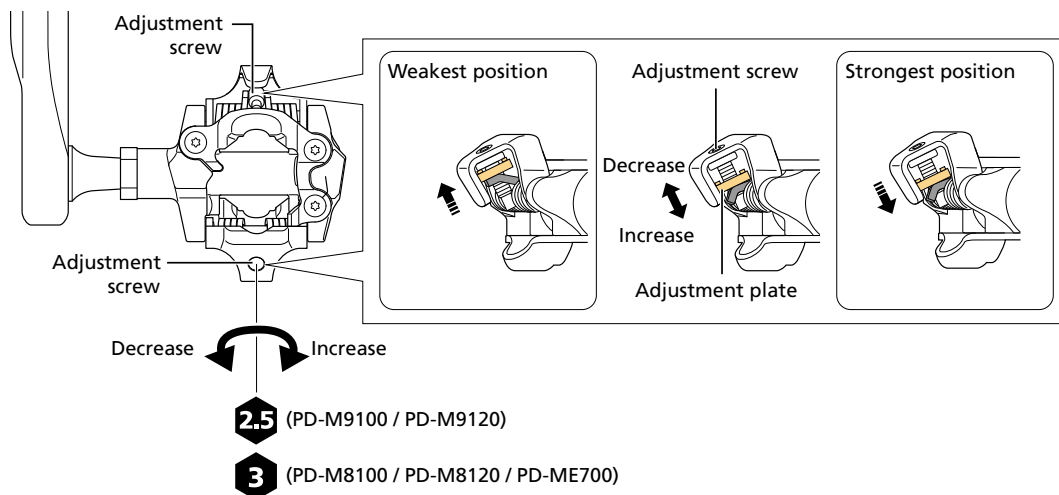

NOTICE

- In order to prevent accidental cleat release and ensure that release is possible when needed, make sure that the cleat holding force is properly adjusted.
- If the cleats are not adjusted equally, it can cause the rider difficulty in engaging or releasing the cleats. The cleat holding force for the right and left pedals should be adjusted so they are equal.

Adjusting axle bearings

Adjustment is required if the rotating parts are not functioning properly. Follow the procedures shown below.

Reference: Parts breakdown

Maintenance

Adjusting axle bearings

PD-M9100 / PD-M9120

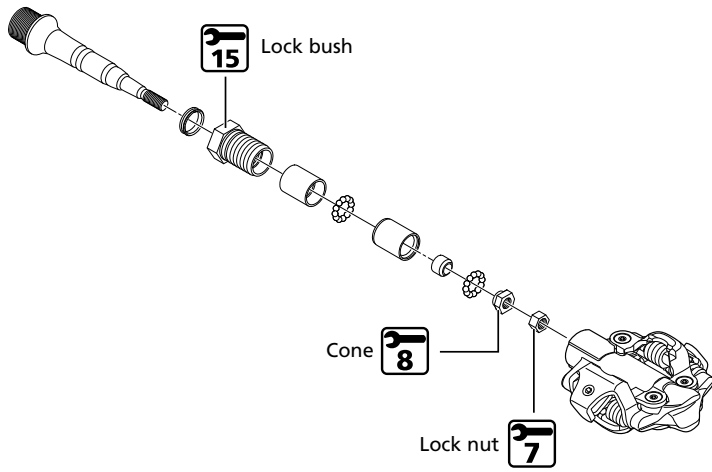

PD-M8100 / PD-M8120

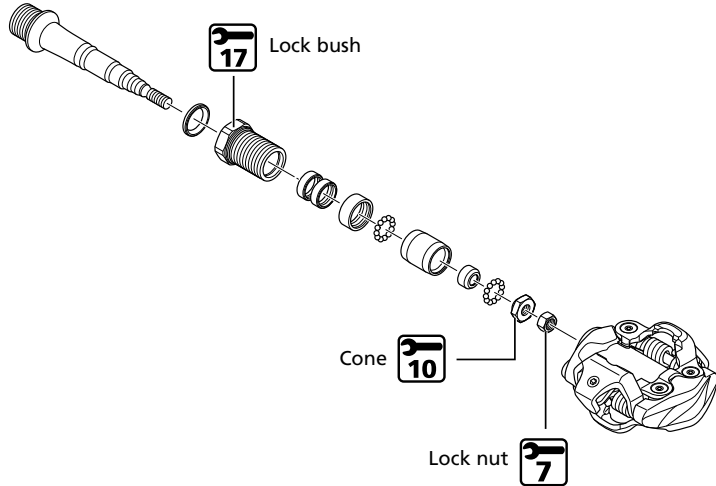

PD-ME700

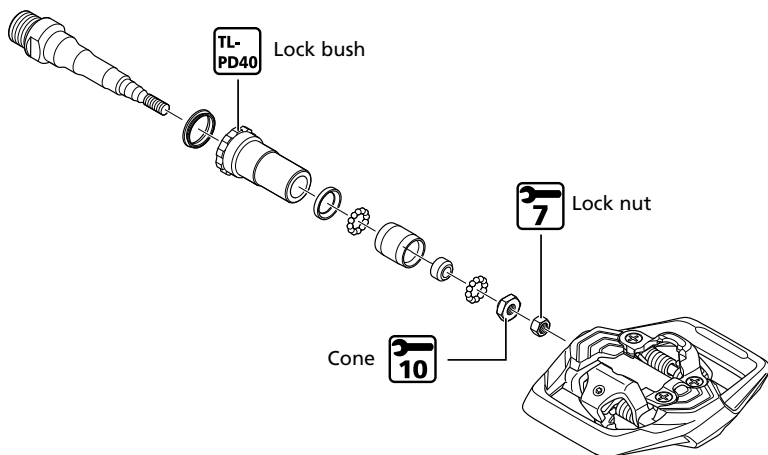

Maintenance

Adjusting axle bearings

1. Loosen the lock bush and remove the axle unit.

The lock bush of the right pedal has a left-hand thread; the lock bush of the left pedal has a right-hand thread.

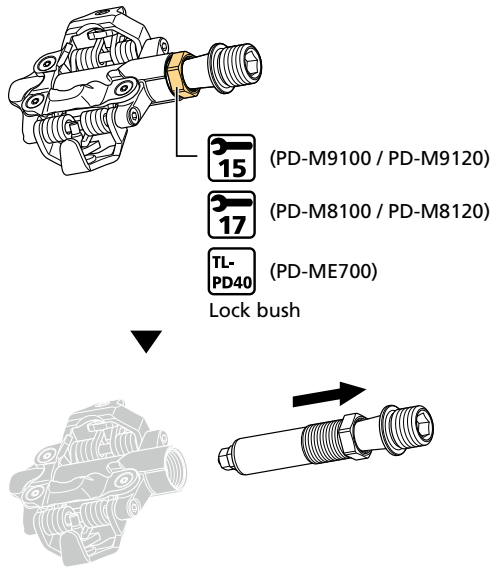

2. Loosen the lock nut.

Use a vise or an axle vise to hold the axle unit in place. Use the tools indicated in the figure to perform the adjustment.

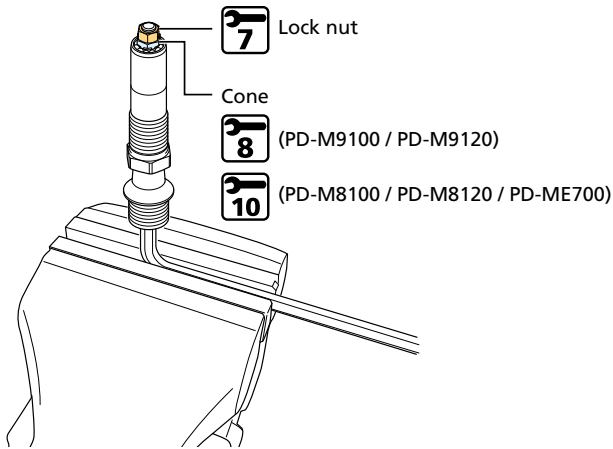

TECH TIPS

PD-M9100 / PD-M9120

- Right-hand thread: Black (without notches)

If the fitted lock nut is black (without notches), the cone and the lock nut have a right-hand thread.



Right-hand thread: Black
(without notches)

- Left-hand thread: Black (with notches)

If the fitted lock nut is black (with notches), the cone and the lock nut have a left-hand thread.



Left-hand thread: Black
(with notches)

- The rotating parts are tightened when the axle unit is set into the pedal. Adjust them slightly loosely before setup.

3. Turn the cone to adjust the bearing preload.

Maintenance

Adjusting axle bearings

4. With the cone held secure, tighten the lock nut in place.

If there is excess play in rotation after setting the axle unit into the pedal, readjust from Step 2 .

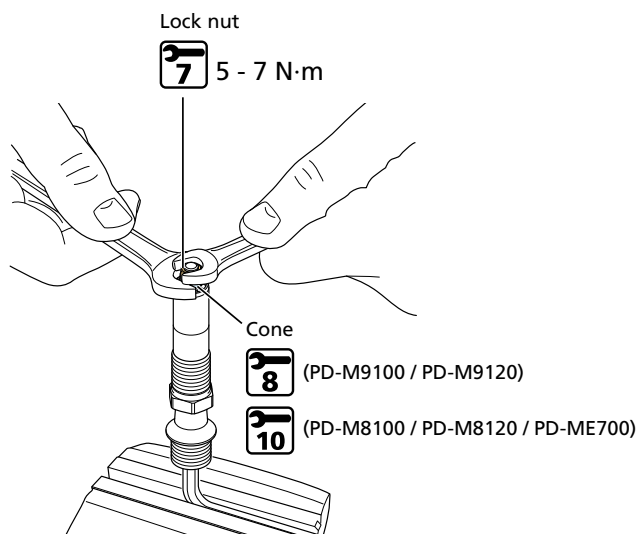

5. Remove old grease and apply an appropriate amount of new grease to the bottom of the pedal body.

TECH TIPS

- Apply grease to the extent that it does not flow out when the axle is set into the pedal (approximately 1.5 g).

6. Insert the axle unit into the pedal body, then tighten the lock bush.

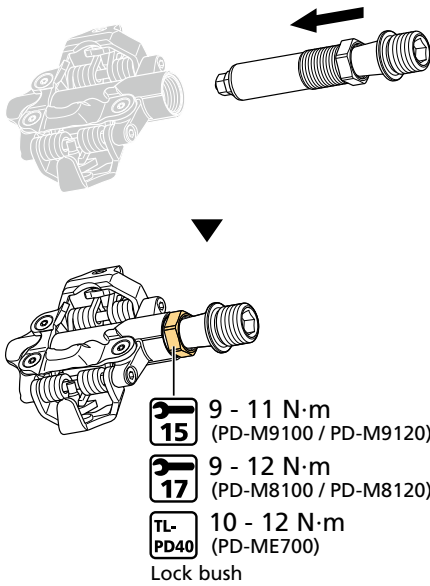

Replacing body covers

Cleats and body covers become worn and need to be replaced periodically.

Cleats and body covers should be replaced when they become difficult to release, or release with much less effort than when they were in new condition.

1. Replace body covers as shown in the figure.

Tighten the three screws uniformly using equal torque.

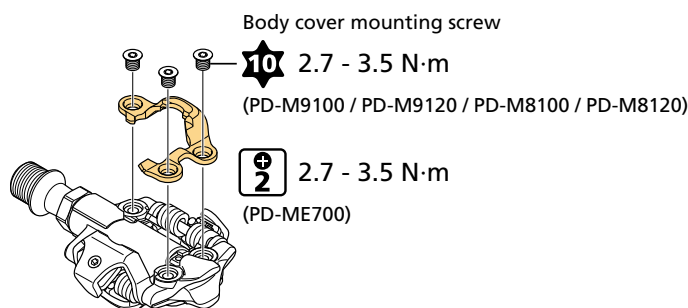

Installing/removing the reflectors

Installing the reflectors

The model of reflector to use varies depending on the type of pedal.

Use SM-PD60 for standard type, or SM-PD22 for short type.

Maintenance

Installing/removing the reflectors

There are left and right types of SM-PD60 reflectors.

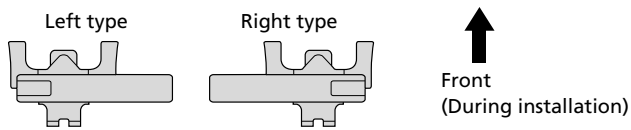

SM-PD60/SM-PD22

1. **Set the spring force to the weakest setting so that the reflector is easier to insert.**

Adjust by turning the adjustment screw on the pedal body.

Adjustment screw

2.5 (PD-M9100 / PD-M9120)

3 (PD-M8100 / PD-M8120 / PD-ME700)

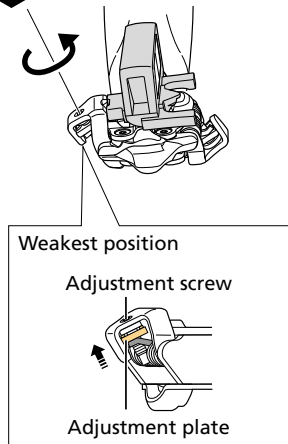

2. Insert the reflector tab into the body cover groove in the pedal body.

SM-PD60

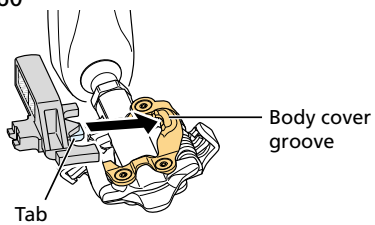

SM-PD22

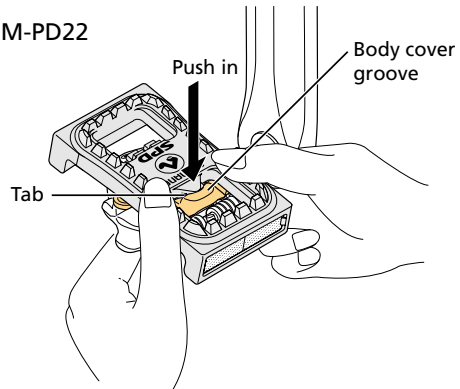

3. Fit the tab on the opposite side into the binding on the pedal body.

As shown in the figure, use a slotted screwdriver or other tool to fit it.



Maintenance

Installing/removing the reflectors

4. Set the spring force to the strongest setting to prevent detachment.

Adjust by turning the adjustment screw on the pedal body.

Adjustment screw

2.5 (PD-M9100 / PD-M9120)

3 (PD-M8100 / PD-M8120 / PD-ME700)

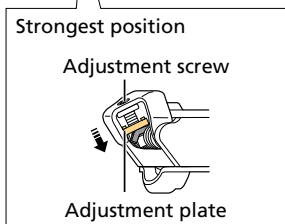

Removing the reflectors

SM-PD60 / SM-PD22

1. Turn the adjustment screw on the pedal body to adjust the spring force to the weakest setting.

Adjustment screw

2.5 (PD-M9100 / PD-M9120)

3 (PD-M8100 / PD-M8120 / PD-ME700)

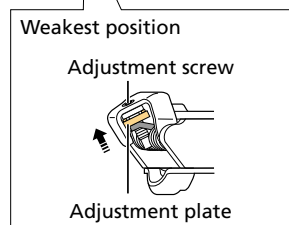

Maintenance

Installing/removing the reflectors

2. Pry the reflector tab out from the binding of the pedal body.

As shown in the figure, use a slotted screwdriver or other tool to pry it out.

* If using the side from which the reflector was removed as the SPD pedal, first readjust the cleat holding force prior to use.

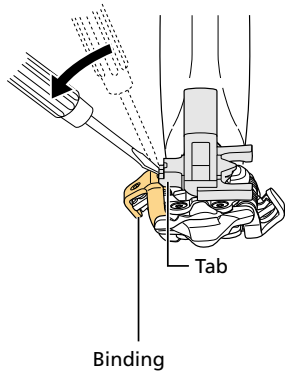

SHIMANO

SHIMANO NORTH AMERICA BICYCLE, INC.
One Holland, Irvine, California 92618, U.S.A. Phone: +1-949-951-5003

SHIMANO EUROPE B.V.
High Tech Campus 92, 5656 AG Eindhoven, The Netherlands Phone: +31-402-612222

SHIMANO INC.
3-77 Oimatsu-cho, Sakai-ku, Sakai City, Osaka 590-8577, Japan

Please note: specifications are subject to change for improvement without notice. (English)
© Feb. 2023 by SHIMANO INC. ITP