

Dealer's Manual

ROAD	MTB	Trekking
City Touring/ Comfort Bike	URBAN SPORT	E-BIKE

Front Hub / Freehub (Disc Brake)

Downhill / Freeride

HB-M820	FH-M820
	FH-M825
	FH-M828
HB-M640	FH-M640
	FH-M645
	FH-M648

Cross-Country

HB-M9010	FH-M9000	SM-AX75
	FH-M9010	SM-AX76
HB-M9010-B	FH-M9010-B	SM-AX76-B
HB-M675	FH-M756	SM-AX78
HB-M678	FH-M675	SM-AX78-B
HB-M615	FH-M678	SM-AX65
HB-M618	FH-M615	SM-AX55
	FH-M618	SM-AX56
	FH-M525	SM-AX56-B
	FH-M475	SM-AX58
		SM-AX58-B

Trekking

HB-T675	FH-T675
---------	---------

MTB

HB-M8000	FH-M8000
HB-M8010	FH-M8010
HB-M8010-B	FH-M8010-B
HB-M756	
HB-M758	AX-MT700
	AX-MT500

CONTENTS

IMPORTANT NOTICE.....	3
TO ENSURE SAFETY.....	4
LIST OF TOOLS TO BE USED.....	8
INSTALLATION	10
Spoke lacing	10
Installation of the disc brake rotor	10
Installing to the frame	13
MAINTENANCE	15
Front hub	15
Freehub.....	21
Replacement of the freewheel body (Quick release type).....	26

IMPORTANT NOTICE

- **This dealer's manual is intended primarily for use by professional bicycle mechanics.**
Users who are not professionally trained for bicycle assembly should not attempt to install the components themselves using the dealer's manuals. If any part of the information on the manual is unclear to you, do not proceed with the installation. Instead, contact your place of purchase or a local bicycle dealer for their assistance.
- Make sure to read all instruction manuals included with the product.
- Do not disassemble or modify the product other than as stated in the information contained in this dealer's manual.
- All manuals and technical documents are accessible online at <https://si.shimano.com>.
- For consumers who do not have easy access to the internet, please contact a SHIMANO distributor or any of the SHIMANO offices to obtain a hardcopy of the User's Manual.
- Please observe the appropriate rules and regulations of the country, state or region in which you conduct your business as a dealer.

For safety, be sure to read this dealer's manual thoroughly before use, and follow it for correct use.

The following instructions must be observed at all times in order to prevent personal injury and physical damage to equipment and surroundings. The instructions are classified according to the degree of danger or damage which may occur if the product is used incorrectly.

 **DANGER**

Failure to follow the instructions will result in death or serious injury.

 **WARNING**

Failure to follow the instructions could result in death or serious injury.

 **CAUTION**

Failure to follow the instructions could cause personal injury or physical damage to equipment and surroundings.

TO ENSURE SAFETY

WARNING

- **Be sure to follow the instructions provided in the manuals when installing the product.**
Only use SHIMANO genuine parts. If a component or replacement part is incorrectly assembled or adjusted, it can lead to component failure and cause the rider to lose control and crash.
-  Wear approved eye protection while performing maintenance tasks such as replacing components.

Be sure to also inform users of the following:

- Check that the wheels are fastened securely before riding the bicycle. You may fall or collide and be seriously injured.

SAINT/ZEE (Downhill/Freeride): HB-M820/FH-M820/FH-M825/FH-M828/HB-M640/FH-M640/FH-M645/FH-M648

- Downhill bicycle riding and freeriding are inherently dangerous activities. There is a risk of being involved in an accident that can result in a serious injury or even death. It is strongly recommended that riders wear protective head and body gear and perform thorough safety checks of their bicycles before riding. Please remember that you are riding at your own risk and that you have to consider your experience and your skills very carefully.
- Before riding the bicycle, you should carefully check your hubs to make sure that there are no cracks in the axles, and if you find any unusual conditions, DO NOT use the bicycle. This front hub is designed for downhill bicycle riding and freeriding. However, depending on the riding conditions, the hub axle could develop cracks that result in the failure of the axle. This can lead to an accident that could result in serious injury or even death.

FH-M820/M825/M640/M645

- If using SM-AX80, confirm that the hub axle has been tightened to a torque of 35 - 45 N·m and the wheel has been secured to the frame. You may fall or collide and be seriously injured if the wheel comes off.

XTR/SLX/DEORE (Cross-Country): HB-M9010/HB-M9010-B/FH-M9010/FH-M9010-B/HB-M678/FH-M678/HB-M618/FH-M618

DEORE XT (MTB): HB-M8010/HB-M8010-B/FH-M8010/FH-M8010-B/HB-M758

- Before riding the bicycle, you should carefully check your hubs to make sure that there are no cracks in the axles, and if you find any unusual conditions, DO NOT use the bicycle. These freehubs are not designed for downhill bicycle riding or freeriding. Depending on the riding conditions, the hub axle could develop cracks. This could result in the failure of the wheel axle, which can lead to an accident resulting in serious injury or even death.
- Make sure that, even if the axle release lever is tightened as much as possible by hand, the axle release lever does not interfere with the disc brake rotor. The axle release lever may interfere with the disc brake rotor if it is on the disc brake rotor side, which is dangerous. If the axle release lever interferes with the disc brake rotor, immediately stop use and contact the place of purchase or a distributor.

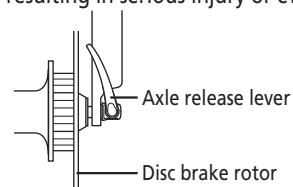

- HB-M678/M618 can be used in combination with a special front fork and the through axle. If used in combination with any other front fork or through axle, it may cause the wheel to become detached from the bicycle while riding and result in serious bodily injury.
- FH-M678/M618 can only be used in combination with a special frame and through axle. If used with any other type of frame, the wheel may come off while the bicycle is being ridden, and serious injury may occur as a result.

XTR/SLX/DEORE (Cross-Country): FH-M9000/FH-M756/HB-M675/FH-M675/HB-M615/FH-M615/FH-M525/FH-M475

DEORE LX (Trekking): HB-T675/FH-T675

DEORE XT (MTB): HB-M8000/FH-M8000

- Make sure that, even if the quick release lever is tightened as much as possible by hand, the quick release lever does not interfere with the disc brake rotor. The quick release lever may interfere with the disc brake rotor if it is on the disc brake rotor side, which is dangerous. If the quick release lever interferes with the disc brake rotor, immediately stop use and contact the place of purchase or a distributor.

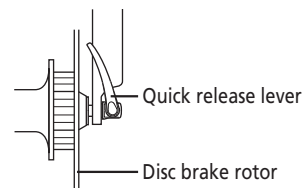

- If it is difficult to install the wheel, install the quick release lever on the disc brake rotor side. If doing this, make sure that the quick release lever does not interfere with the disc brake rotor and that burns do not occur.
- Failure to properly install this quick release hub (wheel) onto the bicycle may cause the wheel to become detached from the bicycle while riding and result in serious bodily injury.
- Read the quick release lever manual carefully, and keep it in a safe place for later reference.

For Installation to the Bicycle, and Maintenance:

- When installing the front wheel to the front fork, always be sure to follow the directions given in the manual for the front fork. The securing method and tightening torque for the front wheel both vary depending on the type of front fork being used. If the instructions are not followed, the front wheel may fall out of the front fork and serious injury may occur. When the front wheel is tightened onto the front fork in accordance with the tightening torque in the manual, the front wheel's rotation may become stiff; however, the instructions must always be followed.
- When installing the rear wheel to the frame, always be sure to follow the directions given in the manual for the frame. When the rear wheel is secured using the tightening torque, the rear wheel's rotation may become stiff; however, the instructions must always be followed. The securing method and tightening torque for the rear wheel both vary depending on the type of frame being used. Improper handling may cause the rear wheel to fall off and lead to serious injury.
- Read the disc brake manual carefully, and keep it in a safe place for later reference.

■ Quick release type

- Use a front fork which is equipped with a wheel retention mechanism.

**For Installation to the Bicycle, and Maintenance:**

- When using the SHIMANO original tool (TL-FC36) to remove and install the disc brake rotor mounting ring, wear gloves and be careful not to touch the outer edges of the disc brake rotor with your hands. Failure to do so may result in cuts to your hands.

NOTICE**Be sure to also inform users of the following:**

- This product is not warranted against damage resulting from improper use, such as jumping while riding or if the bicycle falls over, except if such malfunctions are caused by manufacturing methods.
- Products are not guaranteed against natural wear and deterioration from normal use and aging.
- For maximum performance we highly recommend SHIMANO lubricants and maintenance products.

For Installation to the Bicycle, and Maintenance:

- If the wheel becomes stiff and difficult to turn, perform an inspection.
- Use only the lubricants specified by SHIMANO.
- When replacing the E-THRU Axle, make sure that the replacement E-THRU Axle is of the same model as the current E-THRU Axle attached to the frame.
A different model may not be mounted properly onto the frame due to differences in axle length, screw size, housing diameter, etc.

■ SAINT/ZEE



















- Use the TL-HB16 when attaching the front hub to the wheel truing tool.
- SM-AX75/SM-AX76/SM-AX76-B/SM-AX78/SM-AX78-B/SM-AX65/SM-AX55/SM-AX56/SM-AX56-B/SM-AX58/SM-AX58-B/AX-MT700/AX-MT500 cannot be used because the model is not designed for downhill bicycle riding or freeriding.

The actual product may differ from the illustration because this manual is intended mainly to explain the procedures for using the product.

LIST OF TOOLS TO BE USED

LIST OF TOOLS TO BE USED

The following tools are needed for installation, adjustment, and maintenance purposes.

Tool		Tool		Tool	
	5 mm hexagon wrench		22 mm hub spanner		TL-FH12
	6 mm hexagon wrench		23 mm hub spanner		TL-FH15
	10 mm hexagon wrench		24 mm hub spanner		TL-HB16
	14 mm hexagon wrench		28 mm hub spanner		TL-HS22
	13 mm hub spanner		Hexalobular [#25]		TL-LR15
	17 mm hub spanner		Adjustable wrench		
	20 mm hub spanner		TL-FC36		

INSTALLATION

INSTALLATION

■ Spoke lacing

Check that the spokes have been laced as shown in the illustration.
A radial lacing cannot be used.

Rotating direction of wheel

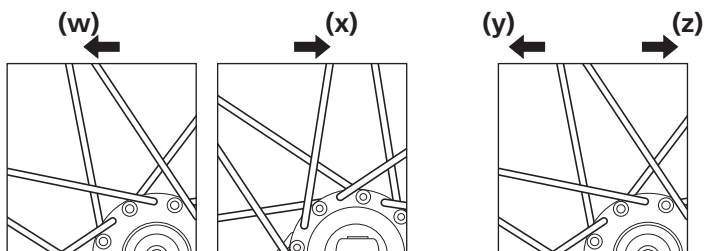

(w) For front: Left (disc brake rotor) side

(x) For front: Right side

(y) For rear: Left (disc brake rotor) side

(z) For rear: Right (sprocket) side

NOTICE

- HB-M820/M678/M640/M618:
Use the SHIMANO original tool TL-HB16 when installing the wheel.
- FH-M828/M678/M648/M618:
Use the SHIMANO original tool TL-FH12 when installing the wheel.

■ Installation of the disc brake rotor

E-THRU Axle/FH-M9000

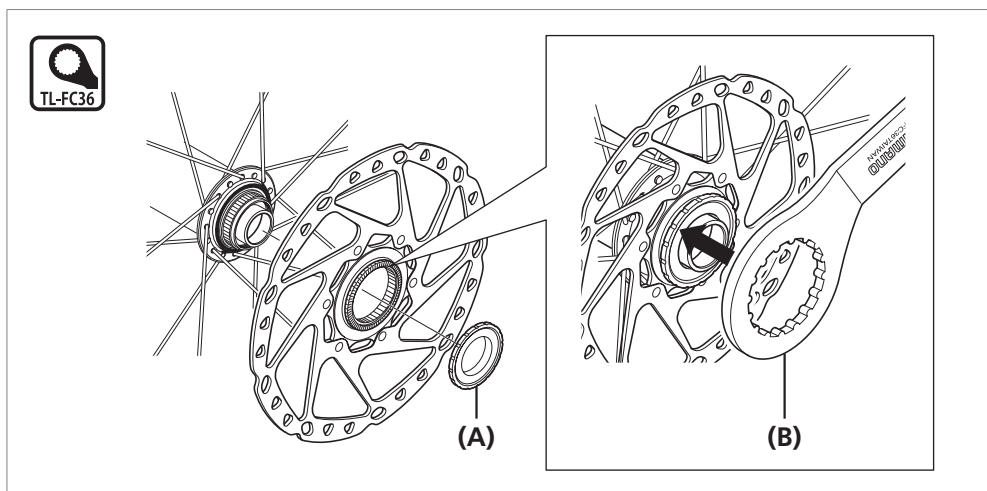

(A) Disc brake rotor fixing lock ring

(B) TL-FC36

Tightening torque



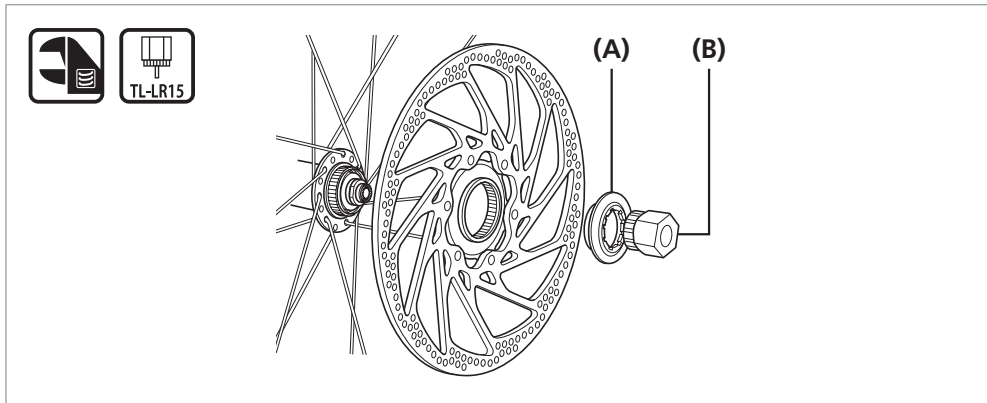

40 N·m

Quick release type



- (A)** Disc brake rotor fixing lock ring
- (B)** TL-LR15

Tightening torque	
 	<p>40 N·m</p>

For 6-screw type

1

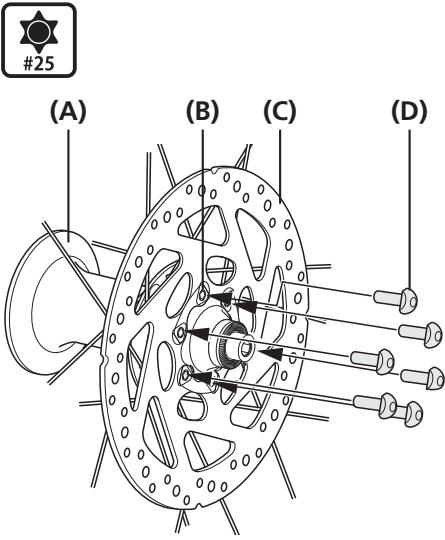

Install the disc brake rotor and the disc brake rotor tightening plate to the hub, and then install and tighten the screws.

- (A)** Hub
- (B)** Tightening plate
- (C)** Disc brake rotor
- (D)** Rotor fixing screw

Tightening torque	
	<p>2 - 4 N·m</p>

2

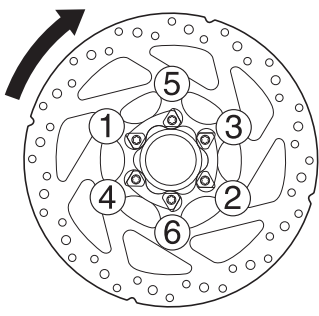

Wear gloves and turn the disc brake rotor clockwise with some force.

While doing this, tighten the rotor fixing screws in the order shown in the illustration.

INSTALLATION

Installation of the disc brake rotor

3

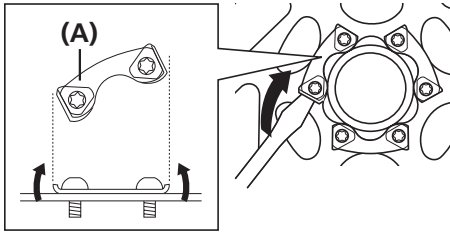

Use a slotted screwdriver or similar tool to bend the edges of the tightening plate over the heads of the screws.

(A) Tightening plate

For 6-screw type (with lock washers)

1

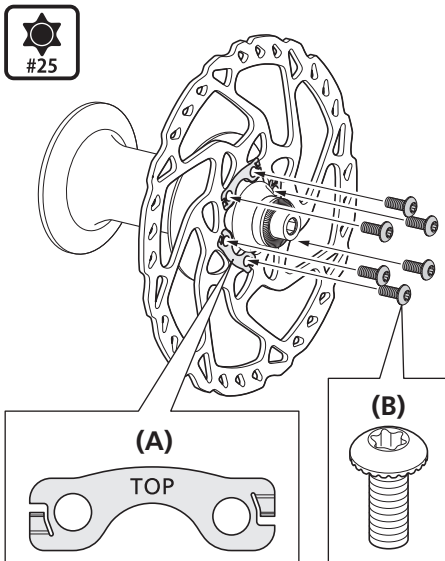

Install the disc brake rotor and rotor lock washers to the hub and tighten the screws.

(A) Lock washer
(B) Rotor fixing screw

Tightening torque



2 - 4 N·m

NOTICE

- Fit the lock washers so that the marking "TOP" is visible.
- The lock washers are not reusable. Always use new lock washers when installing/re-installing the disc brake rotor.
- Use the dedicated rotor fixing screws.

2

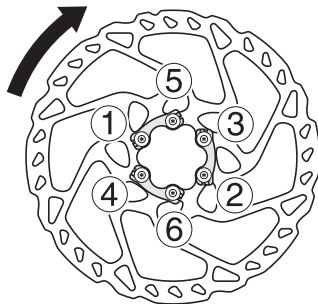

Wear gloves and turn the disc brake rotor clockwise with some force.

While doing this, tighten the rotor fixing screws in the order shown in the illustration.

■ Installing to the frame

FH-M820/M825/M640/M645

When using SM-AX80

1

Install the sprockets to the freehub, place the freehub onto the frame and pass the hub axle through it.

(z) Apply grease

(A) Hub axle
(B) Freehub
(C) Cassette sprocket
(D) Frame

2

Tighten the fixing nut onto the hub axle [1] and then turn the hub axle [2] to secure the freehub to the frame.

* FH-M820/M640 (Ø10/12 mm),
FH-M825/M645 (Ø12 mm)

(y) Apply grease
(z) Right-side protrusion: 20 mm - 30 mm

(A) 6 mm hexagon wrench
(B) Fixing nut

- (A) Hub axle
- (B) Freehub
- (C) Cassette sprocket
- (D) Frame

- (A) 6 mm hexagon wrench
- (B) Fixing nut

Tightening torque	
	35 - 45 N·m

NOTICE

Check that the axle protrudes about 20 mm – 30 mm on the right hand side. If it is not long enough, the wheel may come off because the hub axle does not tighten the hub sufficiently.

MAINTENANCE

MAINTENANCE

The hub can be disassembled as shown in the illustration. Apply grease to the various parts at periodic intervals.

■ Front hub

HB-M640/M820

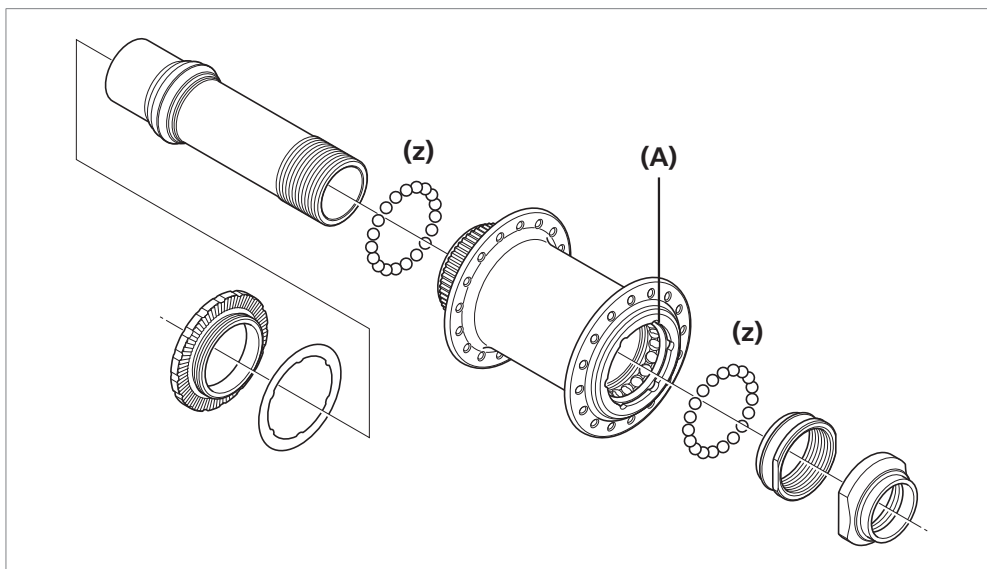

(z) Apply grease:
Premium grease (Y04110000)

(A) Right-side cover of hub

NOTICE

The cover on the right side of the hub unit cannot be disassembled.

Assembly

Install the hub axle, and then use hub spanners as in the illustration to tighten the lock nut so as to double-lock the mechanism.

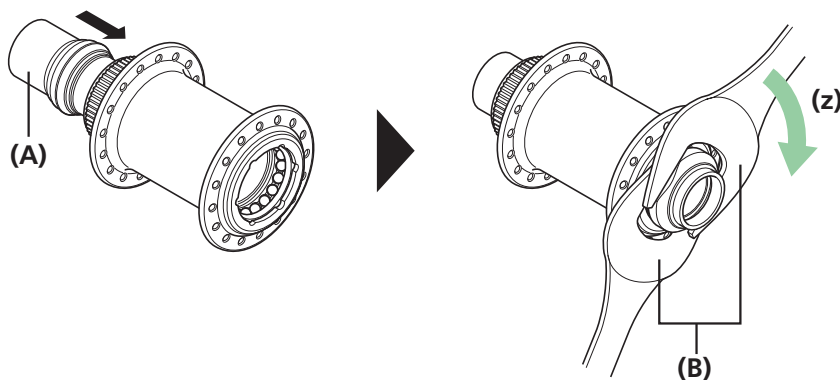

(z) Tighten

(A) Hub axle

(B) 28 mm hub spanner

Tightening torque



30 - 35 N·m

HB-M678

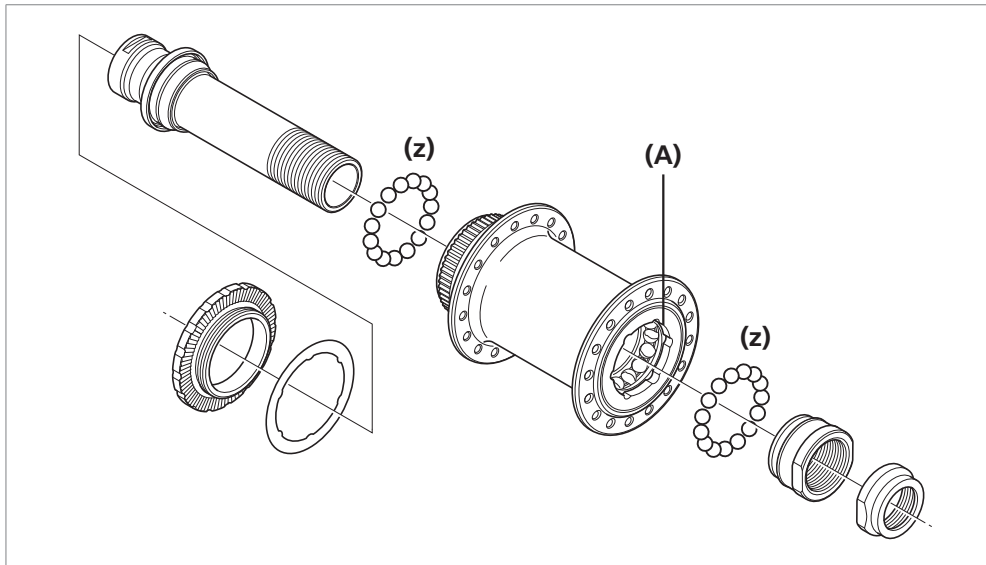

(z) Apply grease:
Premium grease (Y04110000)

(A) Right-side cover of hub

NOTICE

The cover on the right side of the hub unit cannot be disassembled.

Assembly

Install the hub axle, and then use hub spanners as in the illustration to tighten the lock nut so as to double-lock the mechanism.

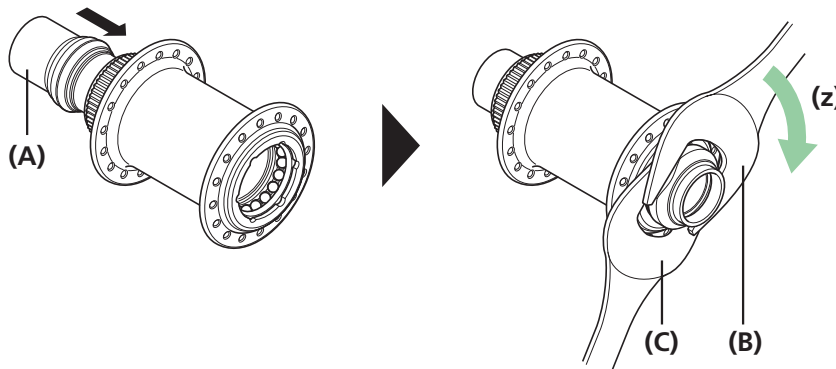

(z) Tighten

(A) Hub axle

(B) 22 mm hub spanner

(C) 23 mm hub spanner

Tightening torque



21 - 26 N·m

HB-M9010/M9010-B/M618/M8010/M8010-B

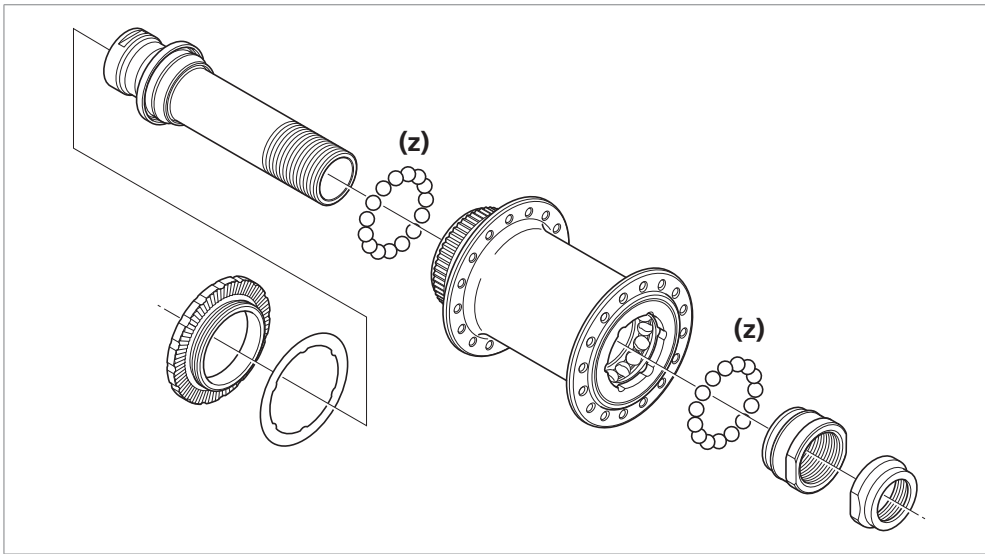

(z) Apply grease:
Premium grease (Y04110000)

Assembly

Install the hub axle, and then use hub spanners as in the illustration to tighten the lock nut so as to double-lock the mechanism.

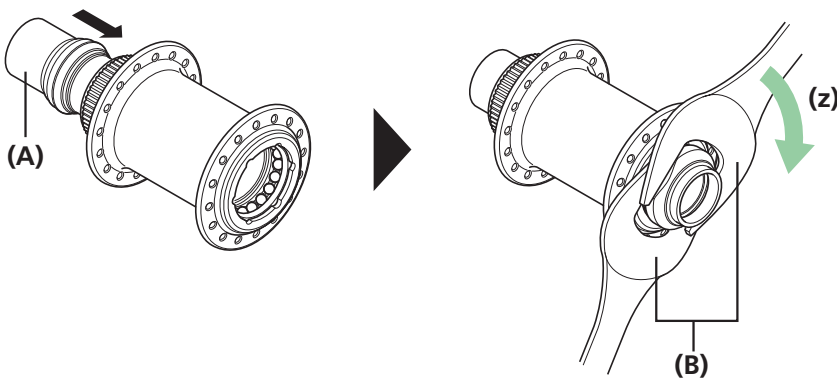

(z) Tighten

(A) Hub axle

(B) 22 mm hub spanner

Tightening torque



21 - 26 N·m

HB-M756

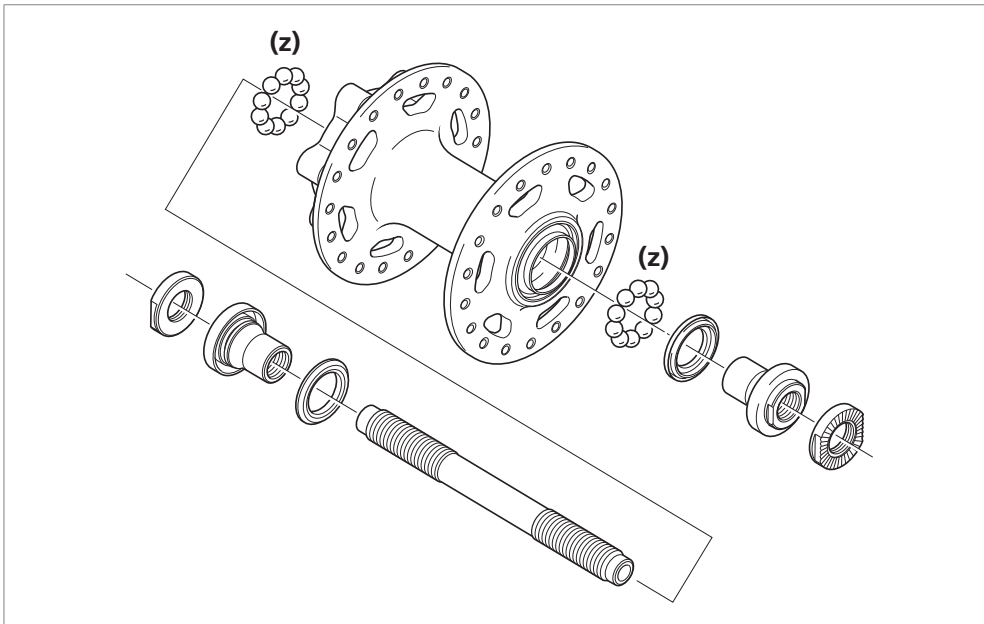

(z) Apply grease:
Premium grease (Y04110000)

Assembly

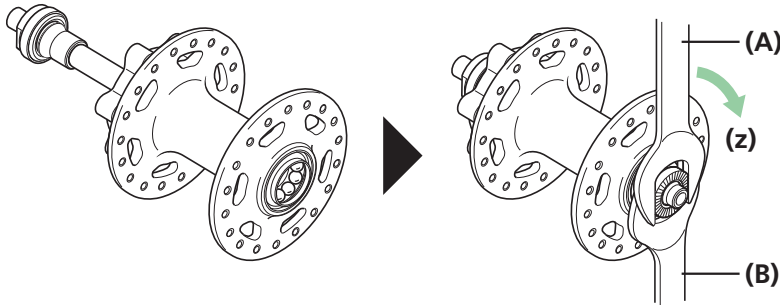

Install the hub axle, and then use hub spanners as in the illustration to tighten the lock nut so as to double-lock the mechanism.



(z) Tighten

(A) 17 mm hub spanner

(B) 13 mm hub spanner

Tightening torque	
 13mm	10 - 15 N·m
 17mm	

HB-M8000

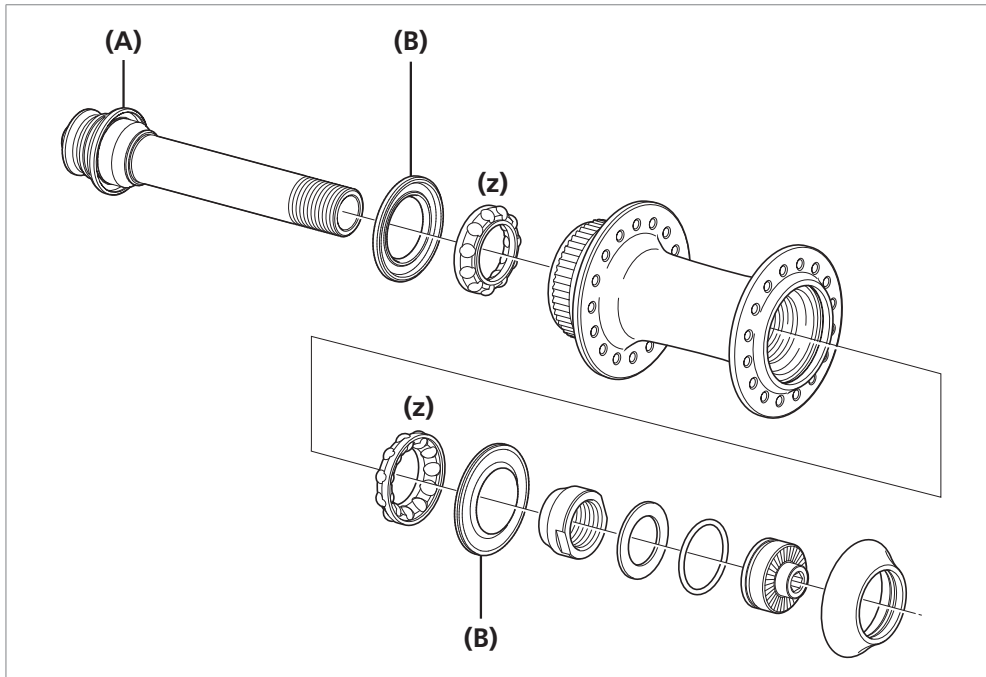

(z) Apply grease:
Premium grease (Y04110000)

(A) Dust cover
(B) Seal

Assembly

Use the SHIMANO original tool (TL-HS22) for installing the hub axle and a 5 mm hexagon wrench to tighten the lock nut so as to double-lock the mechanism as shown in the illustration.

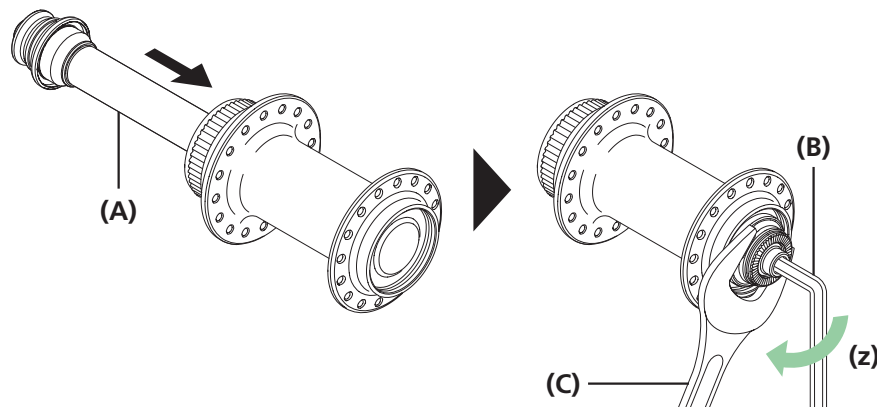

(z) Tighten

(A) Hub axle
(B) 5 mm hexagon wrench
(C) TL-HS22

Tightening torque



15 - 17 N·m

HB-M758

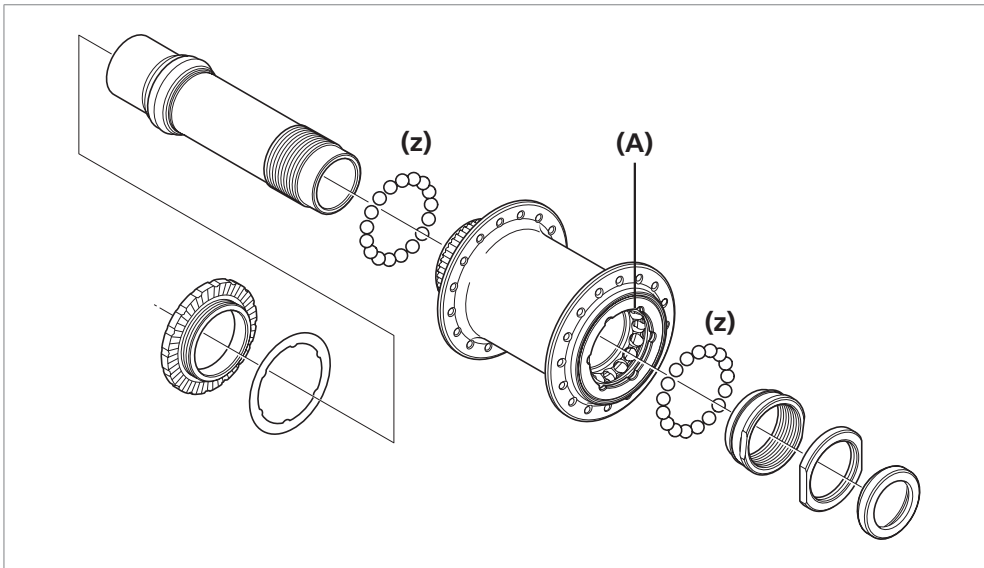

(z) Apply grease:
Premium grease (Y04110000)

(A) Right-side cover of hub

NOTICE

The cover on the right side of the hub unit cannot be disassembled.

Assembly

Install the hub axle, and then use hub spanners as in the illustration to tighten the lock nut so as to double-lock the mechanism.

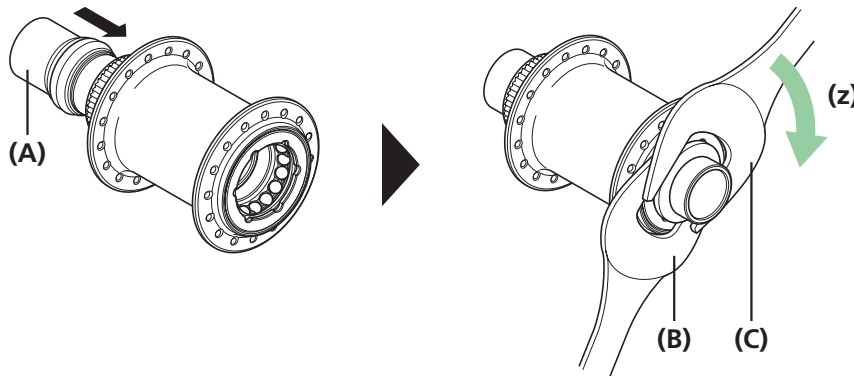

(z) Tighten

(A) Hub axle

(B) 23 mm hub spanner

(C) 24 mm hub spanner

Tightening torque



30 - 35 N·m

Freehub

NOTICE

- When removing and installing the seal, do so very carefully so that the seal does not become bent. When reinstalling the seal, make sure that it is facing the right way, and insert it as far as it will go.
- Do not disassemble the dust covers which are crimped onto the axle, the right nut and the cone.
- Do not attempt to disassemble the freewheel body, because it may result in a malfunction.

FH-M825/M820/M645/M640

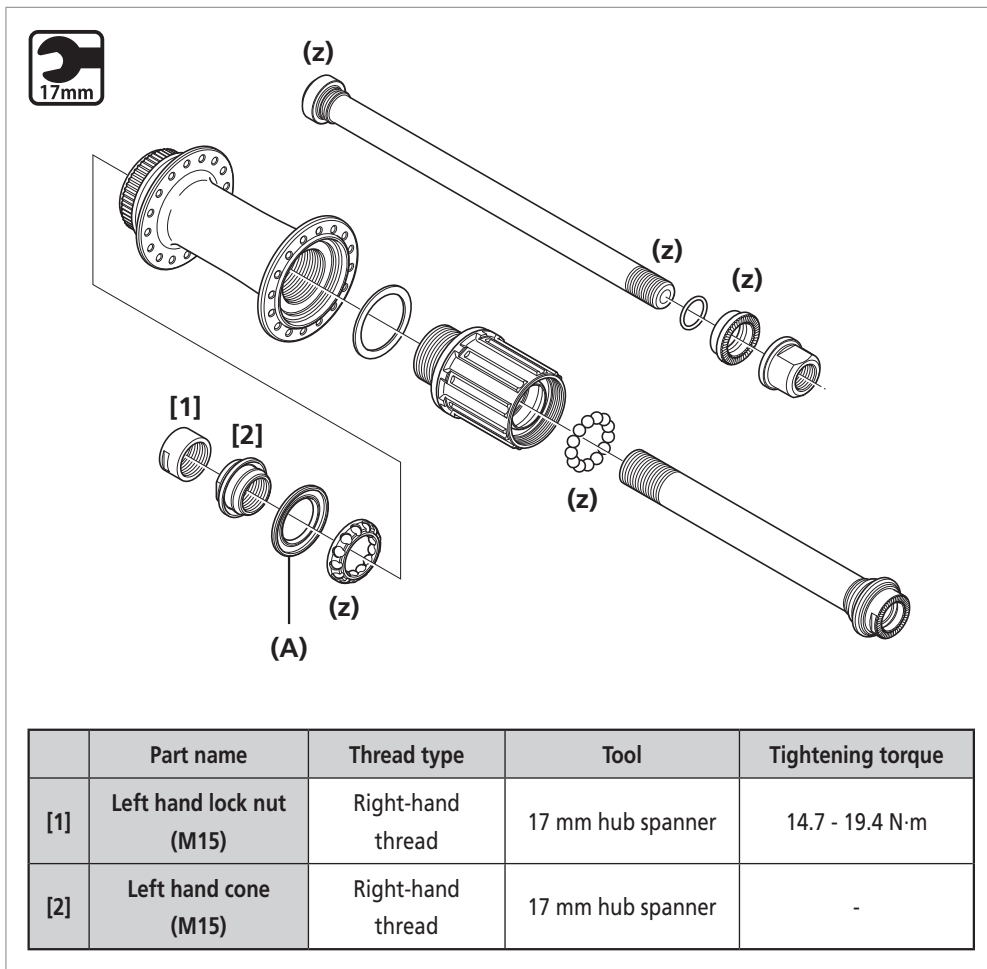

(z) Apply grease:
Premium grease (Y04110000)

(A) Seal (Lip is on the outside)

FH-M9010/M9010-B/M8010/M8010-B/M828/M648/M678/M618

	Part name	Thread type	Tool	Tightening torque
[1]	Left hand lock nut (M15)	Right-hand thread	17 mm hub spanner	15 - 20 N·m
				FH-M9010/FH-M9010-B 16.7 - 22.1 N·m
[2]	Left hand cone (M15)	Right-hand thread	17 mm hub spanner	-
			FH-M9010/FH-M9010-B 20 mm hub spanner	

(z) Apply grease:
Premium grease (Y04110000)

(A) Seal (Lip is on the outside)

NOTICE

The correct position for the dust cover is where it is hidden in the freewheel body, as shown in illustration [1]. If the dust cover is in the position shown in illustration [2], repeat the assembly process from the beginning.

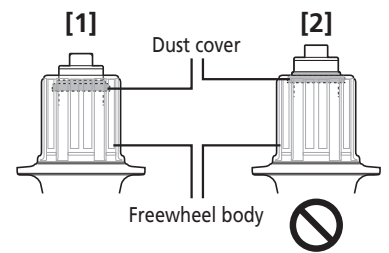

FH-M9000

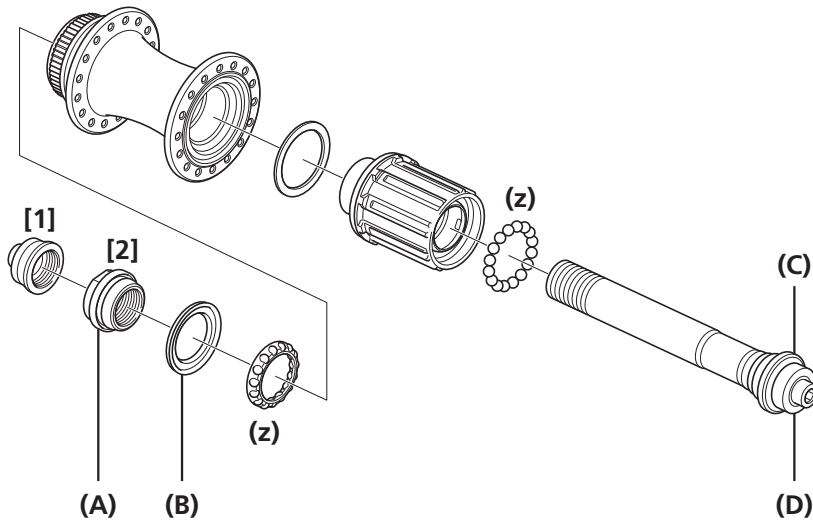

(z) Apply grease:
Premium grease (Y04110000)

- (A) Cone with dust cover
(Cannot be disassembled)
- (B) Seal (Lip is on the outside)
- (C) Dust cover
(Cannot be disassembled)
- (D) Right nut

NOTICE

The correct position for the dust cover is where it is hidden in the freewheel body, as shown in illustration [1]. If the dust cover is in the position shown in illustration [2], repeat the assembly process from the beginning.

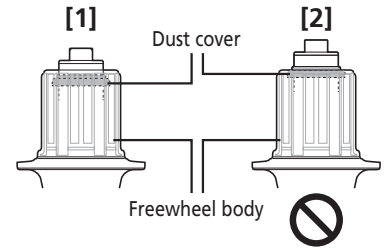

	Part name	Thread type	Tool	Tightening torque
[1]	Left hand lock nut (M15)	Right-hand thread	5 mm hexagon wrench	16.7 - 22.1 N·m
[2]	Left hand cone (M15)	Right-hand thread	20 mm hub spanner	-

FH-M9000/M9010/M9010-B/M8010/M8010-B/M820/M825/M828/M640/M645/M648/M678/M618

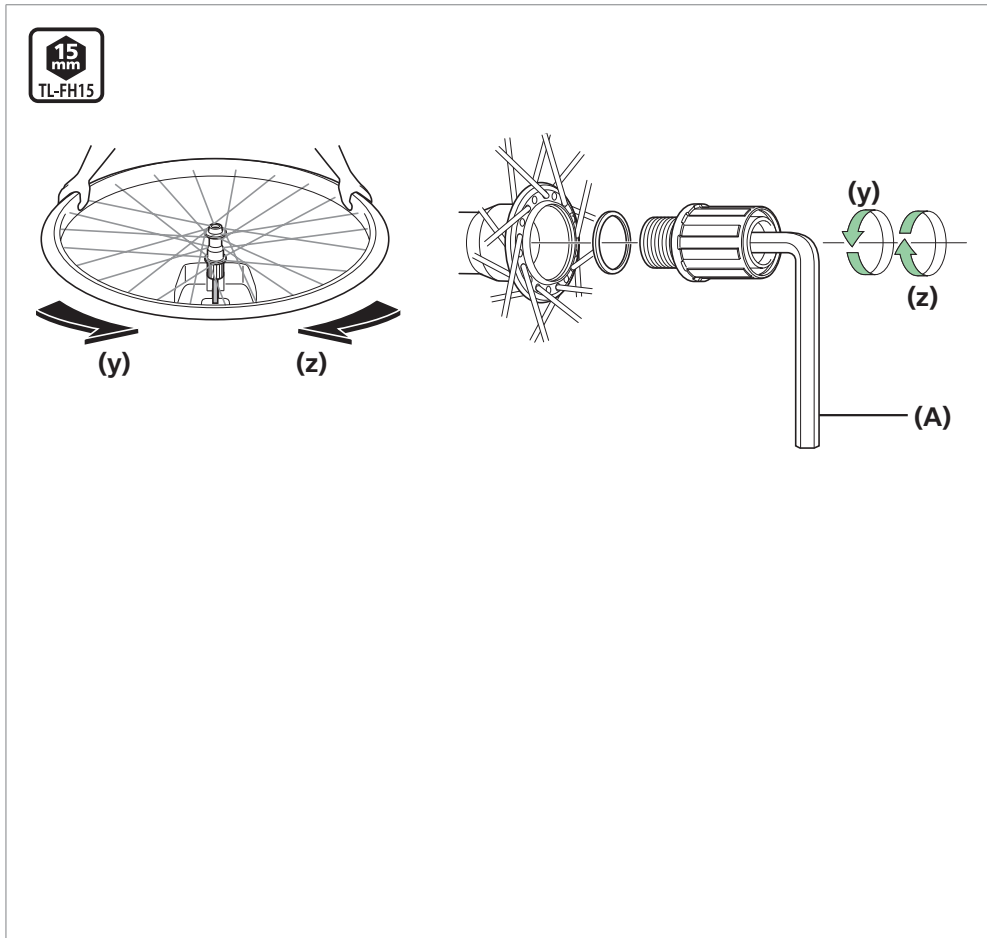

(y) Disassembly

(z) Assembly

(A) TL-FH15

Tightening torque	
	150 N·m

NOTICE

The correct position for the dust cover is where it is hidden in the freehub body, as shown in illustration [1].

If the dust cover is in the position shown in illustration [2], repeat the assembly process from the beginning.

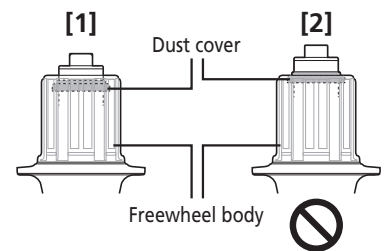

FH-M756/M675/T675/M615/M525/M475

After removing the hub axle, remove the freehub body fixing screw (inside the freehub body), and then replace the freehub body.

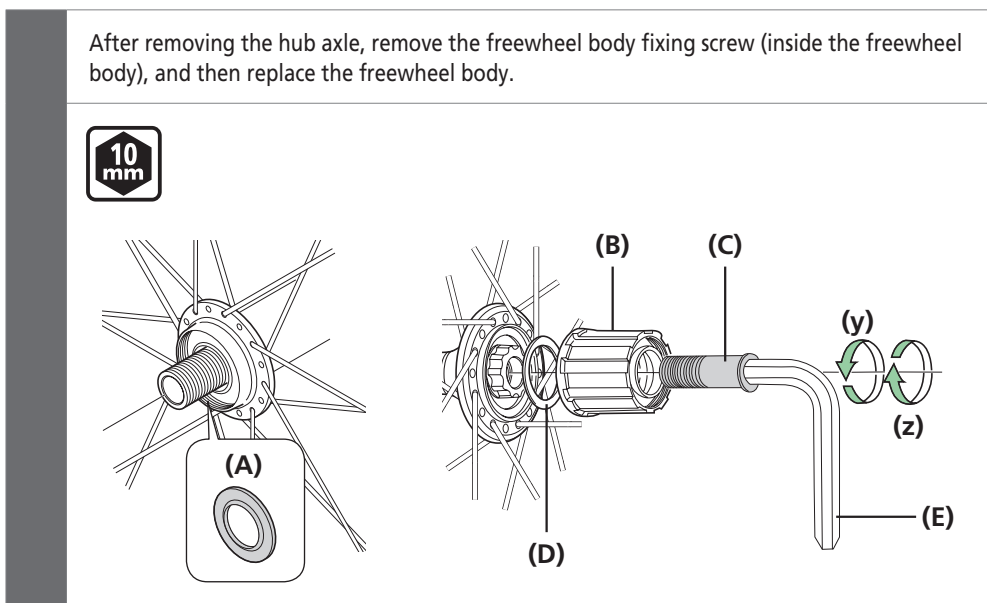

(y) Disassembly

(z) Assembly

(A) Seal (Lip is on the outside)

(B) Freehub body

(C) Freehub body fixing screw

(D) Freehub body washer

(E) 10 mm hexagon wrench (TL-WR37)

Tightening torque	
	35 - 50 N·m

FH-M8000

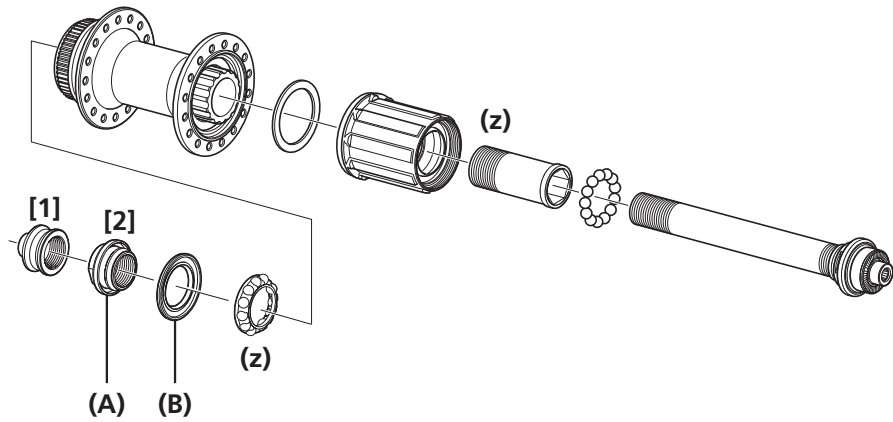

	Part name	Thread type	Tool	Tightening torque
[1]	Left hand lock nut (M15)	Right-hand thread	5 mm hexagon wrench	16.7 - 22.1 N·m
[2]	Left hand cone (M15)	Right-hand thread	17 mm hub spanner	-

(z) Apply grease:
Premium grease (Y04110000)

- (A) Cone with dust cover
(Cannot be disassembled)
- (B) Seal (Lip is on the outside)

NOTICE

The correct position for the dust cover is where it is hidden in the freewheel body, as shown in illustration [1].
If the dust cover is in the position shown in illustration [2], repeat the assembly process from the beginning.

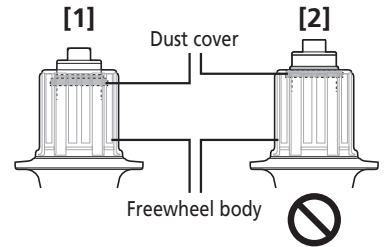

■ Replacement of the freewheel body (Quick release type)

1

[1]

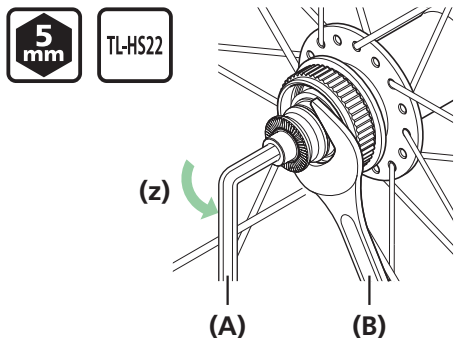

Pull out the hub axle by following procedures [1] to [3].

(z) Disassembly

[2]

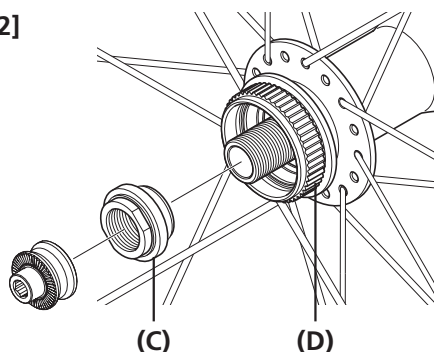

[3]

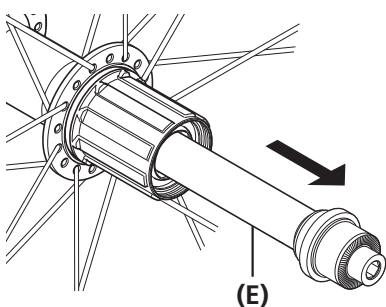

- (A) 5 mm hexagon wrench
- (B) TL-HS22
- (C) Cone with dust cover (Cannot be disassembled)
- (D) Disc brake rotor fixing spline
- (E) Hub axle

Tightening torque



15 - 20 N·m

NOTICE

- Do not disassemble the dust cover which is crimped onto the cone.
- The double-lock section on the freewheel side cannot be disassembled.

2

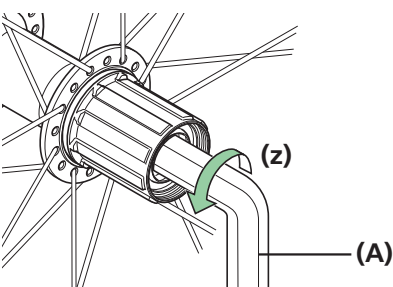

After removing the hub axle, remove the freewheel body fixing screw (inside the freewheel body).

(z) Disassembly

- (A) 14 mm hexagon wrench

Tightening torque (When installing)



45 - 50 N·m

▶▶ Replacement of the freewheel body (Quick release type)

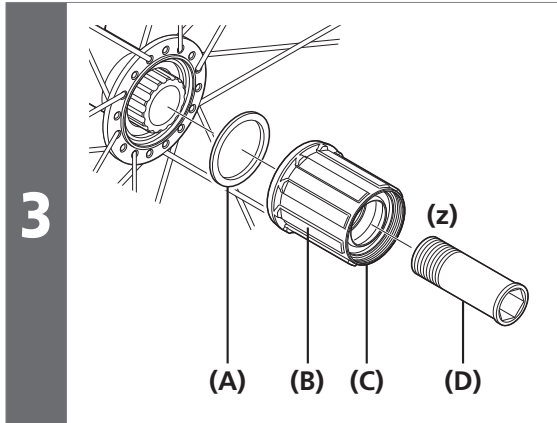

Replace the freewheel body.

When installing, perform the removal procedures in the reverse order.

- (z) Apply grease:
Premium grease (Y04110000)

- (A) Freewheel body washer
- (B) Freewheel body
- (C) Seal (Cannot be removed)
- (D) Freewheel body fixing screw

NOTICE

Be sure to apply grease to the threads of the freewheel body fixing screw, otherwise looseness or sticking may occur.
Do not attempt to disassemble the freewheel body, because it may result in a malfunction.

SHIMANO

SHIMANO NORTH AMERICA BICYCLE, INC.

One Holland, Irvine, California 92618, U.S.A. Phone: +1-949-951-5003

SHIMANO EUROPE B.V.

High Tech Campus 92, 5656 AG Eindhoven, The Netherlands Phone: +31-402-612222

SHIMANO INC.

3-77 Oimatsu-cho, Sakai-ku, Sakai City, Osaka 590-8577, Japan

Please note: specifications are subject to change for improvement without notice. (English)

© Aug. 2021 by SHIMANO INC. ITP