

Dealer's Manual

ROAD	GRAVEL	MTB
E-BIKE	LIFESTYLE	GENERAL

Rear Derailleur (Di2)

GRX
RD-RX825

Contents

IMPORTANT NOTICE	4
TO ENSURE SAFETY	5
List of tools to be used	11
Names of parts	12
How to operate	13
Switching operation modes	13
• LED display	13
• Selecting the shift mode	14
• Bluetooth ® LE connection mode	14
• Adjustment mode	14
• System pairing (wired)	14
• System pairing (wireless)	15
• Charging method	16
• RD protection reset	16
Gear position control	17
• About gear position control	17
Installation/removal	18
Installing the rear derailleur	18
• Standard type	18
• Direct mount type	19
• Connecting the electric wire	20
Adjustment	22
Checking the chain length	22
Installing the chain	24
Adjusting the rear derailleur	25
• Adjusting the B-screw	25
• Gear shifting adjustment	26
• Adjusting the low/high limits	28
Connection and communication with devices	30
E-TUBE PROJECT	30
Items configurable in E-TUBE PROJECT	31
Wireless function	32

• Function	32
Shift mode setting (synchronized shift)	33
• Semi-synchronized shift	33
• Synchronized shift	34
Maintenance	35
Replacing the pulleys	35
Applying grease to the chain stabilizer	36
Adjusting friction	38
Removing the plate, P-tension spring, and switch lever	41
Installing the plate, P-tension spring, and switch lever	44
Replacing the charging port cover	48
Troubleshooting	49
When a problem occurs	49

IMPORTANT NOTICE

- **This dealer's manual is intended primarily for use by professional bicycle mechanics.**

Users who are not professionally trained for bicycle assembly should not attempt to install the components themselves using the dealer's manuals.



If any part of the information on the manual is unclear to you, do not proceed with the installation. Instead, contact your place of purchase or a distributor for assistance.

- Make sure to read all manuals included with each product.
- Do not disassemble or modify the product other than as stated in the information contained in this dealer's manual.
- All manuals and technical documents are accessible online at <https://si.shimano.com>.
- For consumers who do not have easy access to the internet, please contact a SHIMANO distributor or any of the SHIMANO offices to obtain a hardcopy of the user's manual.
- Please observe the appropriate rules and regulations of the country, state or region in which you conduct your business as a dealer.
- The Bluetooth[®] word mark and logos are registered trademarks owned by the Bluetooth SIG, Inc. and any use of such marks by SHIMANO INC. is under license.
Other trademarks and trade names are those of their respective owners.
- ANT[®] and ANT+[®] are trademarks or registered trademarks of ANT Wireless.

For safety, be sure to read this dealer's manual thoroughly before use, and follow it for correct use.

The following instructions must be observed at all times in order to prevent personal injury and physical damage to equipment and surroundings.

The instructions are classified according to the degree of danger or damage which may occur if the product is used incorrectly.

 DANGER	Failure to follow the instructions will result in death or serious injury.
 WARNING	Failure to follow the instructions could result in death or serious injury.
 CAUTION	Failure to follow the instructions could cause personal injury or physical damage to equipment and surroundings.

TO ENSURE SAFETY

DANGER

Be sure to also inform users of the following:

■ Lithium-ion battery

- Use the dedicated charging cable when charging the battery. If any non-specified items are used, fire, overheating or leakage may occur.
- Do not heat the battery or expose it to flames. If this is not observed, combustion or bursting of the battery may occur.
- Do not deform, modify, disassemble, or apply solder directly to the battery. Do not use or leave the battery in places which may exceed 60°C in temperature, such as places which are exposed to direct sunlight, inside vehicles on hot days or near stoves. If this is not observed, leakages, overheating or bursting may cause fire, burns or other injury to occur.
- Do not connect the (+) and (-) terminals with metallic objects. Do not carry or store the battery together with metallic objects such as necklaces or hairpins. If this is not observed, short-circuits or overheating may occur, resulting in burns or other injury.
- If any liquid leaking from the battery gets into your eyes, immediately wash the affected area thoroughly with clean water such as tap water without rubbing your eyes, and seek medical attention immediately. If this is not done, the battery liquid may damage your eyes.
- If the battery does not become fully charged after 4 hours of charging, stop charging. If this is not observed, fire, bursting, ignition, or overheating may occur.

■ Charging cable

- Do not get the charging cable wet and do not touch or hold it while it is wet or with wet hands. If this is not observed, problems with operation or electric shocks may occur.
- Use an AC adapter with a USB port that has a voltage of 5.0 V DC and a current equal to or higher than 1.0 A DC. If the one with a current lower than 1.0 A is used, the AC adapter may heat up, potentially causing a fire, smoke, overheating, destruction, electric shock, or burns.

■ Rear derailleur

- Do not place this product in water, and do not allow the terminals to get wet. If this is not observed, fire, bursting, ignition, or overheating may occur.

WARNING

- **Be sure to follow the instructions provided in the manuals when installing the product.**

Only use SHIMANO genuine parts. If a component or replacement part is incorrectly assembled or adjusted, it can lead to component failure and cause the rider to lose control and crash.

-  Wear approved eye protection while performing maintenance tasks such as replacing components.

Be sure to also inform users of the following:

- Do not disassemble or modify the product. This may cause the product to not operate correctly, and you may suddenly fall and be seriously injured.

■ Lithium-ion battery

- Do not use the battery if leakages, discoloration, deformation or any other abnormalities occur. If this is not observed, bursting, overheating or problems with operation may occur.

■ Charging cable

- When connecting or disconnecting the USB cable or the charging cable, be sure to hold the cable by the plug. Failure to do so may cause a fire or electric shock.
- If the following symptoms are observed, stop using the device and contact your place of purchase. A fire or electric shock may be caused.
 - If heat, acrid smell, or smoke is coming out from the power plug.
 - There may be a bad connection inside the power plug.
- If it thunders while charging with an AC adapter with a USB port, do not touch the device, bicycle, or the AC adapter. If lightning strikes, electric shocks may occur.
- Do not use a USB hub when connecting the cable to a PC USB port. This may cause a charging error or fire due to overheating.
- Be careful not to damage the charging cable. Do not damage, process, forcibly bend, twist or pull it, bring it near hot objects, place heavy objects on it or bundle it tightly together. If it is used while damaged, fire, electric shocks or short circuits may occur.
- Do not let grease adhere to the metal terminals. A conduction failure may result.

■ Rear derailleur

- Do not throw or subject this product to strong shocks. If this is not observed, bursting, overheating or problems with operation may occur.
- Clean the chain and QUICK-LINK with an appropriate chain cleaner regularly. Intervals between maintenance depend on the use and riding circumstances. Never use alkali- or acid-based solvents such as rust cleaners. If those solvents are used the chain or QUICK-LINK might break and cause serious injury.
- Check the chain for any damage (deformation or cracking), skipping, or other abnormalities such as unintended gear shifting. The chain may break, and you may fall.

CAUTION

Be sure to also inform users of the following:

- Keep out of reach of children.
- Do not leave the charging cable connected when performing maintenance.

NOTICE

Be sure to also inform users of the following:

- For SHADOW RD+ models, be sure to check that the plate unit cover is installed before riding the bicycle.
- The gears should be periodically washed with a neutral detergent then lubricated. In addition, cleaning the chain and QUICK-LINK with a neutral detergent and lubricating them can be an effective way of extending the life of the chain and QUICK-LINK.
- Do not use the thinners or harsh solvents to clean the products. Such solvents may damage the surface.
- If gear shifting operation does not feel smooth, consult the place of purchase for assistance.
- If you feel the chain or other drivetrain components skipping, consult the place of purchase for assistance.
- If there is a large amount of excess play in the pulleys and extra noise is generated while riding, replace the pulleys at your place of purchase.
- The electric wire has small waterproof plugs, so do not repeatedly connect and disconnect it too often. Doing so may impair the waterproofing.

- The components are designed to be fully waterproofed to withstand wet weather riding conditions; however, do not deliberately place them into water.
- Do not clean the bicycle with a high-pressure wash. If water gets into any of the components, operating problems or rusting may result.
- Contact the place of purchase for updates of the component firmware. The most up-to-date information is available on the SHIMANO website.
- Do not get the charging cable or charging port wet when connecting them.
- Be careful not to get water into the E-TUBE ports when the ports are empty.
- Handle the components carefully, and avoid subjecting them to strong shock.
- Disconnect the Bluetooth[®] LE connection when not using E-TUBE PROJECT Cyclist. The rear derailleur does not shift gears when connected over Bluetooth[®] LE.
- 2.4 GHz digital wireless

This product adopts digital communication technologies in the 2.4 GHz frequency, which are used for wireless LAN, etc. It may receive interference in the following locations or environments that prevent wireless communication from being performed correctly:

- Near a device such as a television, computer, radio, or motor, or inside an automobile or railway car
 - Near a railway crossing or railway track, television transmitting station, or radar base, etc.
 - When using the device in combination with another cordless device or some lights
- When not using Bluetooth[®] LE or the ANT[®] function, wireless communication function can be disabled. For the setting procedure, refer to the user's manual for E-TUBE PROJECT.

E-TUBE PROJECT Cyclist:



https://si.shimano.com/um/7J4MA/other_settings#task_ynb_fwv_1mb

E-TUBE PROJECT Professional:



https://si.shimano.com/um/7J4WA/other_settings#task_qmg_snh_tlb

- Do not bundle the charging cable.
- Do not connect the rear derailleur to PC when it is on standby. This may cause a PC failure depending on its specifications.
- Do not apply excessive tension to the charging cable.
- Do not extend the charging cable using an extension cable etc. Extending the cable may disrupt charging.
- Do not ride the bicycle while the charging cable is still connected to it.
- Charging stops if E-TUBE PROJECT is connected while charging. Reconnect the charging cable after E-TUBE PROJECT is disconnected.
- Charge the battery indoors to avoid exposure to rain or wind.
- Charging can be carried out at any time regardless of the battery level. Always use the dedicated charging cable and charge the battery until it is fully charged.
- If the ambient temperature is low, the battery's usable time will be shorter.

- Store this product or the bicycle with this product installed in a cool indoor location away from direct sunlight and rain (approx. 10 - 20°C). If the storage temperature is too low or too high, the performance of the battery is reduced, and its usable time will be shorter. When you use the battery after a long storage period, make sure to charge it first.
- When the battery is completely depleted, charge it as soon as possible. If you leave the battery without charging it, it will cause the battery to deteriorate.
- The battery is an exhaustible item. The battery will gradually lose its capacity to charging after repeated use. If the length of time that the battery can be used and its traveling distance become extremely short, contact the place of purchase.
- Connect the battery charger directly to the USB port on a PC, without using an intermediate device such as a USB hub.
- Do not connect two or more of the same units when connecting the electric wire. If this is not done, the units may not operate correctly.
- Do not connect or disconnect units again while unit recognition is in progress or after recognition is complete. If this is not done, the units may not operate correctly.

Check the procedures which are given in the user's manual for the E-TUBE PROJECT when connecting and disconnecting units again.

- Do not connect two or more PC linkage devices at the same time. If two or more PC linkage devices are connected at the same time, they will not operate correctly. In addition, the PC may need to be restarted if operating errors occur.
- Do not use or leave the rear derailleur in places which may exceed 80°C in temperature, such as near fire or stoves.
- When cleaning the product, use a cloth moistened with a diluted neutral detergent.
- Products are not guaranteed against natural wear and deterioration from normal use and aging.
- For maximum performance we highly recommend SHIMANO lubricants and maintenance products.

For installation to the bicycle and maintenance

- Contact SHIMANO INC. for information regarding the shipment of the rear derailleur to South Korea and Malaysia.
- Be sure to adjust the high limit screw and the low limit screw according to the instructions given in the adjustment section. If these instructions are not observed, the chain may become clamped between the spokes and the largest sprocket and the wheel may lock, or the chain may fall off the small sprocket.
- Periodically clean the shifting unit and lubricate all moving parts (mechanisms).
- If gear shifting adjustments cannot be carried out adequately, the rear dropout may not be properly aligned. Use the SHIMANO TL-RD11 to check and align the rear dropout.
- Some pulleys have arrows on them to indicate the direction of rotation. In that case, install the pulley so that the rotation direction of the pulley matches the direction of the arrows when the crank is turned in the forward direction.

■ Connection and communication with PC

- PC linkage devices can be used to connect a PC to the bicycle (system or components), and E-TUBE PROJECT Professional can be used to carry out tasks such as customizing single components or the whole system and updating their firmware.

If your version of E-TUBE PROJECT Professional and the firmware for each component are not up to date, there could be problems operating the bicycle. Check the versions and update them to the latest ones.

	PC linkage device	E-TUBE PROJECT Professional	Firmware
BT-DN300	SM-PCE02	Version 5.0.0 or later	Version 4.0.0 or later

The actual product may differ from the illustration because this manual is intended mainly to explain the procedures for using the product.

For installation to the bicycle

■ Notes on reinstalling and replacing components

- System pairing is required after reinstalling or replacing the dual control levers or rear derailleur. Perform system pairing with a wired or wireless connection.
- If the component configuration changes or malfunction is observed, use E-TUBE PROJECT to update the firmware of each component to the latest version and perform a check again. Also, make sure that E-TUBE PROJECT is the latest version. If the software is not the latest version, the component compatibility or the product functions may not be available.

Be sure to also inform users of the following:

■ Connection and communication with smartphone

- E-TUBE PROJECT Cyclist can be used to carry out tasks such as customizing single components or the whole system and updating their firmware, after connecting the bicycle (system or components) to a smartphone via Bluetooth® LE.
- Disconnect the Bluetooth® LE connection when not using E-TUBE PROJECT Cyclist.

Using the rear derailleur communication function without disconnecting the Bluetooth® LE connection increases battery consumption.

■ Compatibility with E-TUBE PROJECT

- Check the following website for information on compatibility with each unit and functional limitations. (<https://bike.shimano.com/e-tube/project.html>)

■ About the multi-shifting function

- Connecting this system to E-TUBE PROJECT and switching [Multi shift] to [ON] will allow you to continuously shift gears while the shift switch is held down. When modifying this setting, carefully read “ [Items configurable in E-TUBE PROJECT](#) ” in this dealer's manual.

■ Gear-shifting interval

- [Gear-shifting interval] can be set to one of five levels as a multi-shifting function setting in E-TUBE PROJECT: [Very fast], [Fast], [Normal], [Slow], or [Very slow] (Default: [Normal]).

- A faster [Gear-shifting interval] setting will result in faster gear shifting. The rider can quickly adjust the traveling speed and the speed at which the crankset turns (“cadence” below) in response to changes in riding conditions.







However, if a gear shifting operation is performed at an insufficient cadence when the system is set to a fast gear-shifting interval, the chain may be unable to follow the movement of the rear derailleur, resulting in the following problems:

- The chain may slip over the tip of the cassette teeth
 - The cassette may deform
 - The chain may break
- Fully understand the features of the gear-shifting interval, then set the gear-shifting interval according to the riding conditions, such as the terrain and the riding style of the rider.

Gear-shifting interval	Benefits	Drawbacks
Fast setting	<ul style="list-style-type: none"> • Quick multi-shifting is possible • The rider can quickly adjust the cadence or traveling speed in response to changes in the riding conditions 	<ul style="list-style-type: none"> • A high cadence is required when gear shifting • Unintended over-shifting occurs easily
Slow setting	<ul style="list-style-type: none"> • Gear shifting can be performed reliably 	<ul style="list-style-type: none"> • Gear shifting takes some time

List of tools to be used

The following tools are needed for installation/removal, adjustment, and maintenance purposes.

Tool	
	TL-EW300
	2 mm hexagon wrench
	3 mm hexagon wrench
	4 mm hexagon wrench
	5 mm hexagon wrench
	5.5 mm spanner
	Cross head screwdriver [#2]

Names of parts

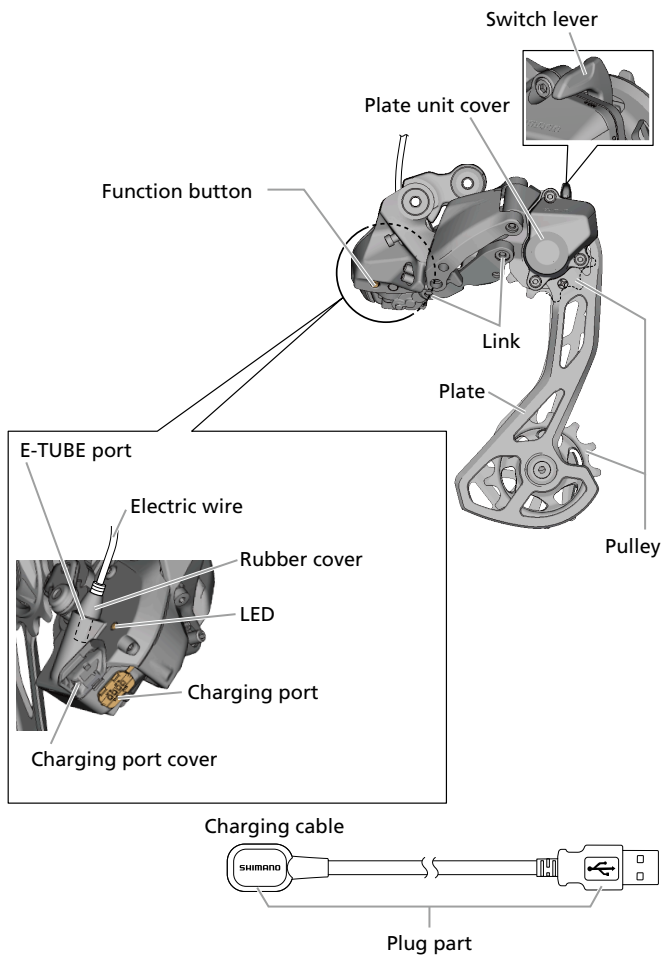

⚠ WARNING

- Use the compatible dedicated battery. Failure to do so may cause bursting or ignition. Refer to “Line-up chart” on our website (<https://productinfo.shimano.com>) for details about compatible batteries.

How to operate

Switching operation modes

Tap, or press and hold the function button to switch the operation mode.







Single click: Check battery level	
Double click: Select shift mode	
0.5 - 2 seconds	Bluetooth® LE connection mode(Flashing blue)
2 - 5 seconds	Adjustment mode(Yellow)
5 - 8 seconds	System pairing(Flashing blue)(when using wired connection)
Press and hold	

NOTICE

- While charging, functions such as gear shifting, adjustment mode, system pairing and changing shift modes will be disabled.
- When connected to E-TUBE PROJECT, charging the battery is disabled.



LED display

	Lighting pattern		State
During battery charging 	●	Blue	Charging
	○	Off	Charging complete
	⦿	Flashing red	Charge error
Checking the battery level (press once) 	●	Green (3 seconds)	51% - 100%
	⦿	Flashing green (8 times)	26% - 50%
	●	Red (3 seconds)	1% - 25%
	○	Off	0%
Selecting the shift mode (by double-clicking) 	●	Blue (2 seconds)	Manual shift
	⦿	Flashing blue (twice)	Shift mode 1
	⦿	Flashing blue (3 times)	Shift mode 2
Bluetooth® LE connection mode (press and hold 0.5 - 2 sec)	⦿	Flashing blue	-

	Lighting pattern		State
Adjustment mode (press and hold 2 - 5 sec)		Yellow	-
System pairing (wired) (press and hold 5 - 8 sec)		Flashing blue	Waiting for wired pairing
		Flashing green (5 times)	Wired pairing (success)
		Flashing red (5 times)	Wired pairing (failure)

Selecting the shift mode

Double-click the function button to switch the shift mode. The LED changes as indicated below each time the shift mode switches.

Lighting pattern		State
	Blue (2 seconds)	Manual shift
	Flashing blue (twice)	Shift mode 1
	Flashing blue (3 times)	Shift mode 2

Bluetooth[®] LE connection mode

E-TUBE PROJECT Cyclist may be used if a Bluetooth[®] LE connection is established with a smartphone.

For details, refer to “ [Items configurable in E-TUBE PROJECT](#) .”

Adjustment mode

You can adjust the gear shifting of the front derailleur and rear derailleur.

Refer to “ [Gear shifting adjustment](#) ” for the rear derailleur adjustment.

Refer to “ [Adjusting the front derailleur](#) ” in the “Front Derailleur (Di2)” dealer's manual for information on front derailleur adjustment.

System pairing (wired)

When using the components that are already connected, the procedures in [1](#), [2](#), and [4](#) are not required.

1. Prepare the charged battery and the three electric wires.

TECH TIPS

- Wired pairing can be performed with a spare battery.

2. Connect the rear derailleur and dual control levers to the prepared battery.

If an electric wire is connected to the rear derailleur, replace it with the prepared electric wire.

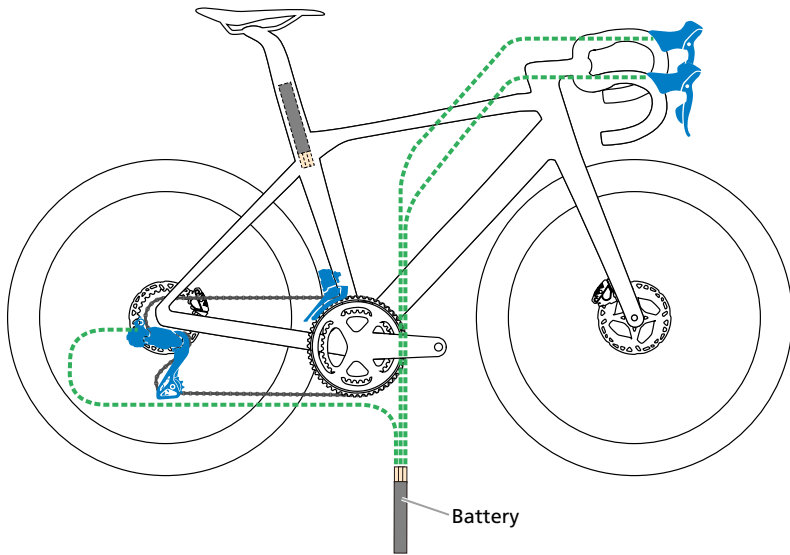

3. **Press and hold the function button until the LED changes from yellow to flashing blue. (5 - 8 seconds)**
System pairing is performed. The LED flashes green if system pairing succeeds, or flashes red if pairing fails.

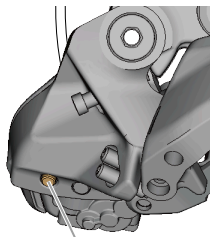

Function button

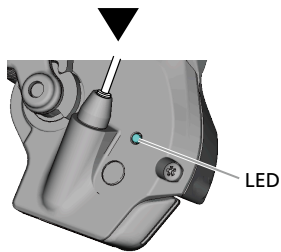

NOTICE

- Individual sides of the dual control levers cannot be paired separately.

4. **Remove the prepared battery and electric wires.**
5. **After connecting each component, check component operation.**

For information on the specific checking methods, refer to "[Checking connections](#)" in the "GRAVEL Di2 Series General Guide."

System pairing (wireless)

E-TUBE PROJECT can be used to perform wireless system pairing of the rear derailleur and dual control levers. For details, refer to the [user's manual for E-TUBE PROJECT](#).

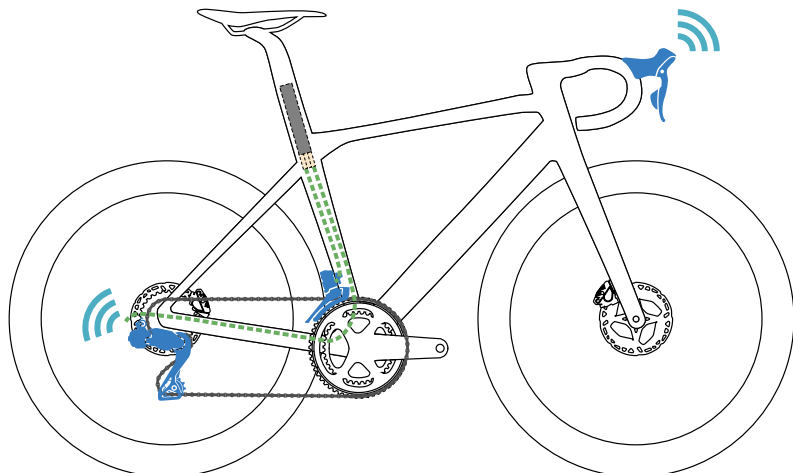

Charging method

For the charging method, refer to “ [Charging method](#) ” in the user's manual for the rear derailleur (Di2).

RD protection reset

In order to protect the system when the bicycle falls and is subjected to a strong impact, the RD protection function will activate and momentarily sever the connection between the motor and link, disabling function of the rear derailleur.

Performing the following operation will recover the rear derailleur from the RD protection function:

1. **While turning the crank arm, operate the shift switch to shift to the largest sprocket.**
2. **While turning the crank arm, operate the shift switch to shift to the smallest sprocket.**

Gear position control

About gear position control

This gear shifting system is programmed to prevent certain gear positions based on combinations of chainring and sprocket, in order to maintain appropriate gear shifting performance. Therefore, gear shifting operations may differ from the basic operations of the shift switch.

When shifting the front derailleur

When the chain is in the position indicated as (1) in the figure, operating the shift switch for front gear shifting does not shift the front derailleur. Instead, the rear derailleur is shifted to the largest sprocket side by two gears.

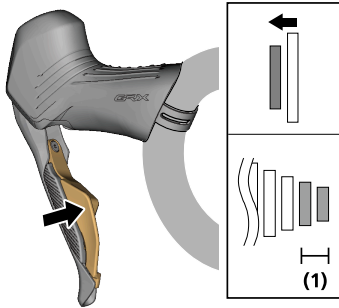

When shifting the rear derailleur

When the chain is at the smallest chainring, the rear derailleur does not shift in the range indicated as (1) in the figure.

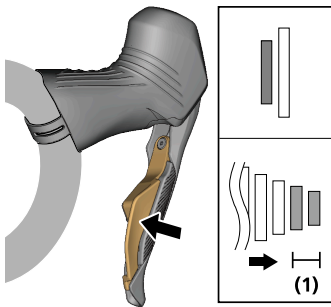

NOTICE

- The gear position control settings differ according to the combination of gears used.
- The gear position control setting may be canceled depending on the combination of rear derailleur and cassette being used. When changing the settings, make sure to select the correct gear combination in the customization menu of E-TUBE PROJECT. (The gear position control setting of 52-36T, 50-34T, or 48-31T cannot be canceled.)
- If the correct gear combination is not selected, the performance of the gear shifting system may not be guaranteed. For the gear position control settings, refer to the [user's manual for E-TUBE PROJECT](#).

Installation/removal

Installing the rear derailleur

TECH TIPS

- The rear derailleur will not gear shift properly if the derailleur hanger is not straight. Use TL-RD11 to check whether the derailleur hanger is straight or not.
- It is recommended to move the switch lever to the ON position while riding to reduce chain slap and to help prevent the chain from falling off the sprockets.

Standard type

1. **Set the switch lever in the OFF position.**

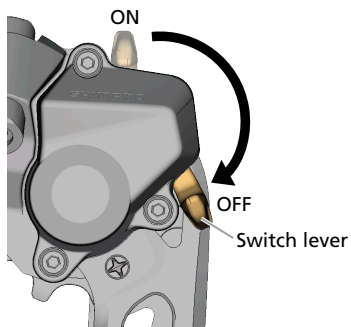

2. **Install the rear derailleur.**

Be careful not to insert the mounting screw in the derailleur hanger at an angle. In addition, be sure to install the rear derailleur so that the stopper plate contacts the B-tension stop with no gap in between.

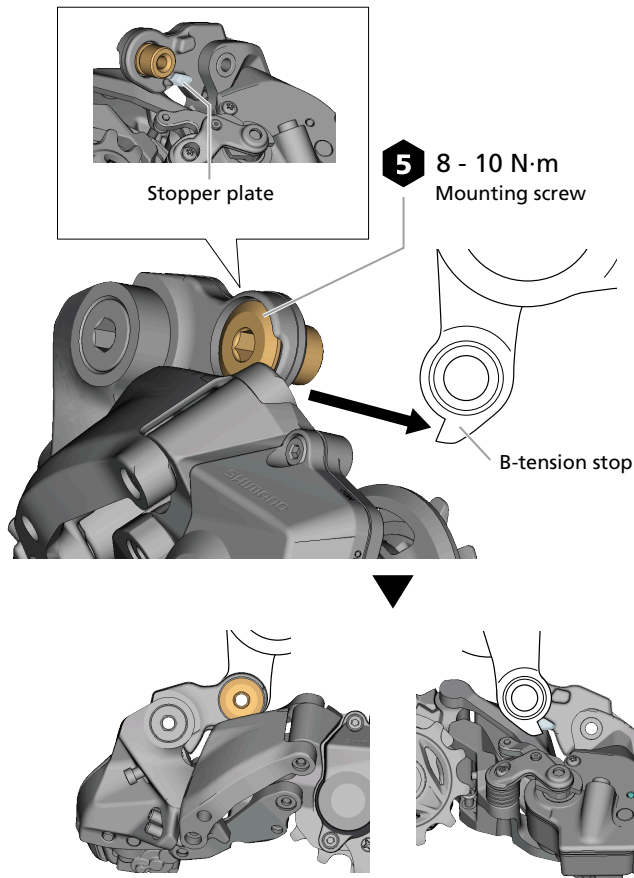

NOTICE

- Periodically check to make sure that there is no gap between the B-tension stop and the stopper plate. If there is a gap between these two parts, problems with gear shifting performance may occur.

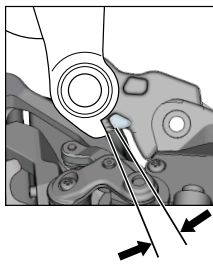

Direct mount type

1. Set the switch lever in the OFF position.

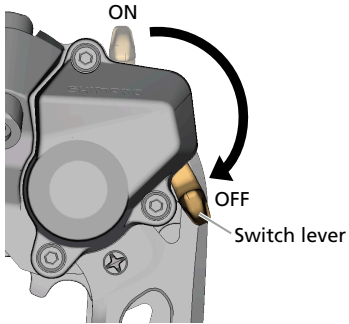

2. Remove the bracket axle plate.

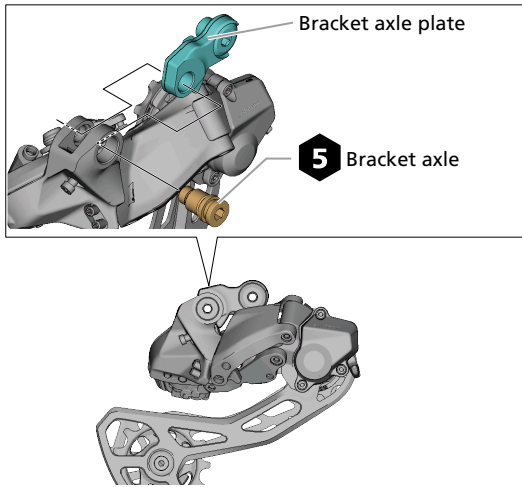

3. Install the rear derailleur.

- (1) Insert the derailleur hanger into the installation part for direct mount of the rear derailleur.
- (2) Install the rear derailleur with the bracket axle.

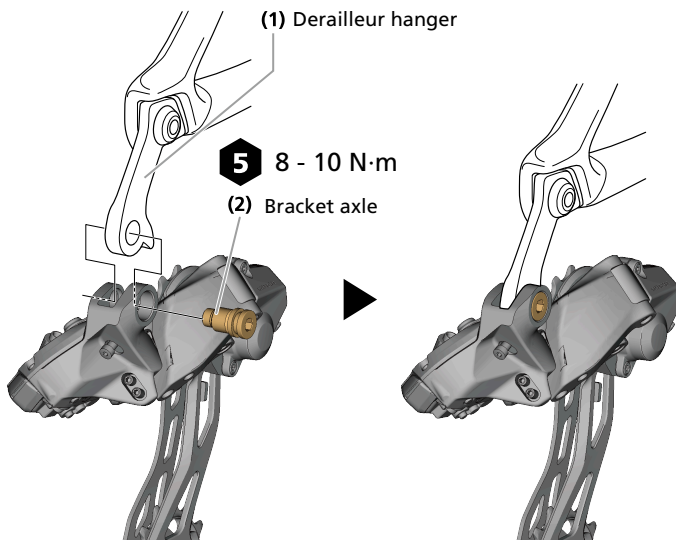

Connecting the electric wire

1. Set the rubber cover over the electric wire.

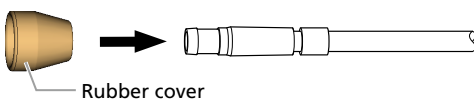

2. Connect the electric wire.

(1) Be sure to push it in firmly with the TL-EW300 until you feel a click.

For instructions on using the TL-EW300, refer to the [“GRAVEL Di2 Series General Guide” dealer's manual](#).

(2) Firmly set the rubber cover against the rear derailleur.

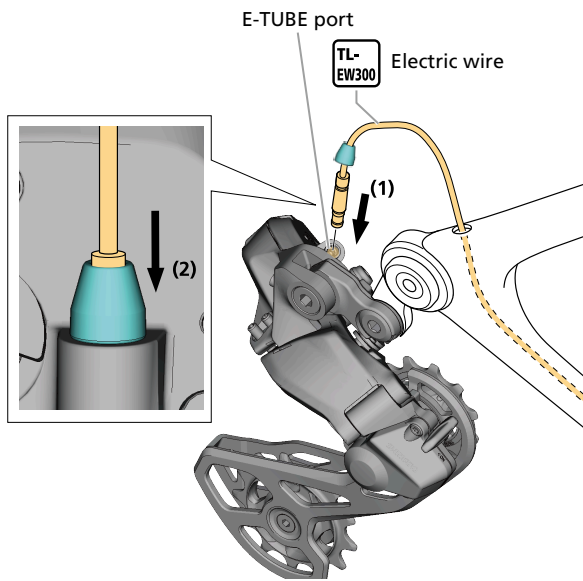

TECH TIPS

- When using the cable guide, pass the electric wire through as shown in the figure.

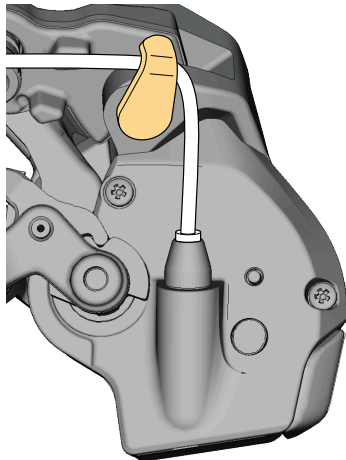

Adjustment

Checking the chain length

1. Mount the chain on the largest sprocket and the largest chainring.

In order to check the length at the rear of the cassette, join the two ends of the chain at the rear of the cassette as shown in the figure.

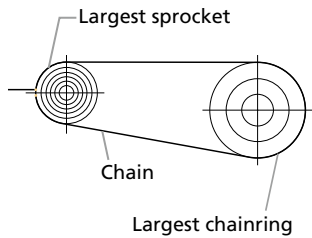

2. Check the length of the chain.

With the zero point of the chain established on the rear of the largest sprocket, add 3 - 4 links to set the length of the chain as shown in the figures.

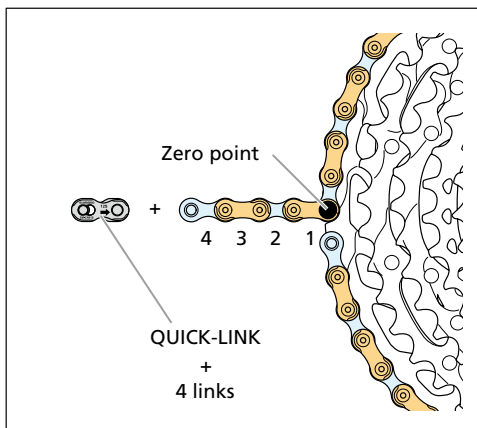
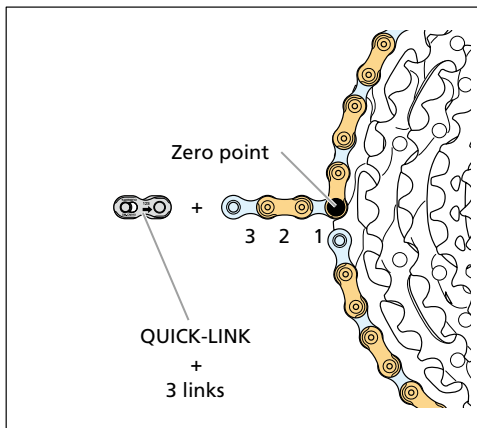

NOTICE

Adjustment

Checking the chain length

- The rear derailleur plate assembly is equipped with a pin or plate that prevents chain derailment. When routing the chain through the rear derailleur plate assembly, route it so that it is on the rear derailleur body side of the chain derailment prevention plate, as shown in the figure. If the chain is not passed through the correct position, damage may be caused to the chain or the rear derailleur.

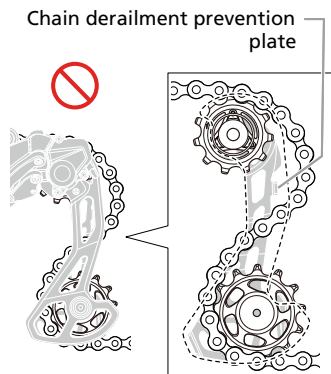
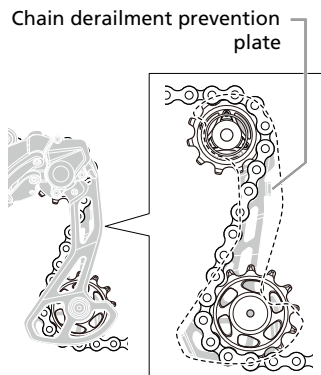

Installing the chain

Refer to the [dealer's manual for the chain](#) to find instructions on installing/removing the chain.

Adjusting the rear derailleur

Adjusting the B-screw



1. Shift the chain to the smallest chainring and the largest sprocket.

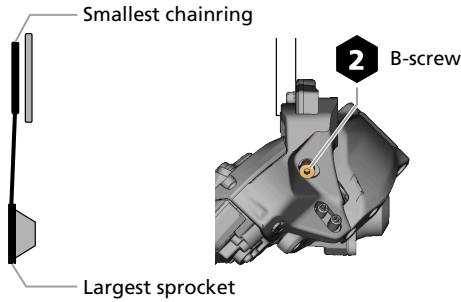

NOTICE

- If there is interference between the sprocket and pulley cage when gear shifting, tighten the B-screw to a position that eliminates the interference.

2. Adjust the B-screw.

Adjust the distance between the tip of the guide pulley and the tip of the highest tooth on the largest sprocket as listed in the table.

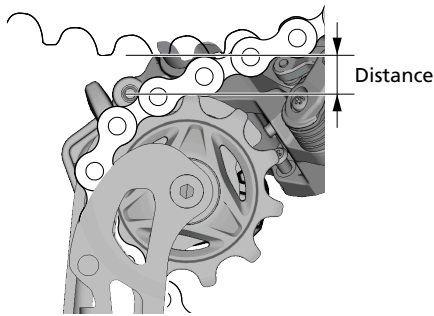

Cassette	Distance between largest sprocket and guide pulley
11-34T	10 mm
11-36T	6 mm

TECH TIPS

Adjustment Adjusting the rear derailleur

- The B-screw can also be adjusted using the included G-pulley setting tool. Set the G-pulley setting tool on the plate as shown in the figure, and align the tip of the largest sprocket with the line of the G-pulley setting tool using the B-screw.

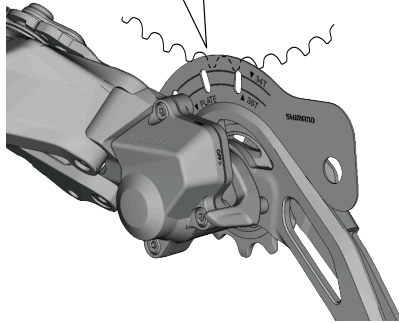
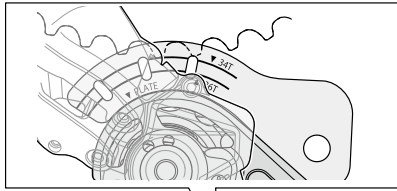

- G-pulley setting tools differ depending on the model. Use the G-pulley setting tool upon confirming the models listed on it.

3. Turn the crank arm to shift gears and ensure that the shift is smooth.

NOTICE

- Perform this adjustment again when using a cassette with a different number of teeth.

Gear shifting adjustment



1. Shift the rear derailleur to the fifth gear position from the largest sprocket.

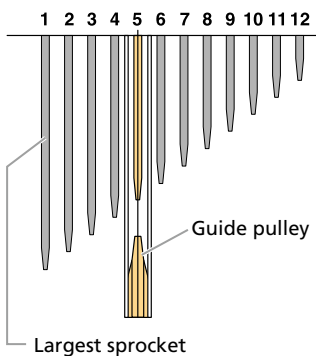

2. Switch the gear shifting system to adjustment mode.

Press and hold the function button for 2 - 5 seconds until the LED switches from blue to yellow. The LED lights yellow when the system switches to adjustment mode.

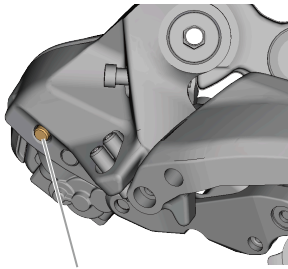

Function button

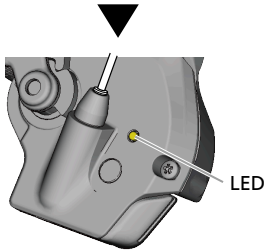

LED

3. Press shift switch [X] while turning the crank arm, and move the guide pulley toward the largest sprocket. Move it to the position where the chain makes contact with the fourth gear and a subtle noise is heard.

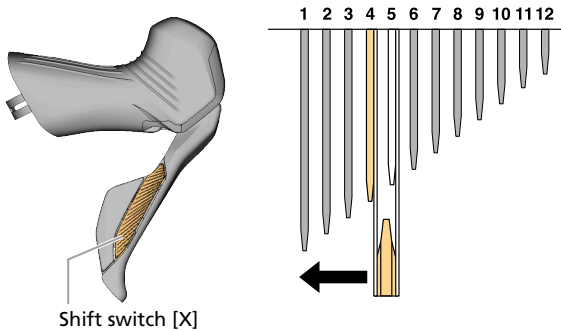

Shift switch [X]

TECH TIPS

- The derailleur can move 18 steps inward and 18 steps outward from the initial position, for a total of 37 positions.
- In adjustment mode, the guide pulley will overrun slightly, then move back in an exaggerated manner so that you can check the adjustment direction. When checking the positions of the guide pulley and the gear, perform the check when the rear derailleur has come to a stop.

4. Press shift switch [Y] five times, and move the guide pulley five steps toward the smallest sprocket. This position will serve as the target for adjustment.

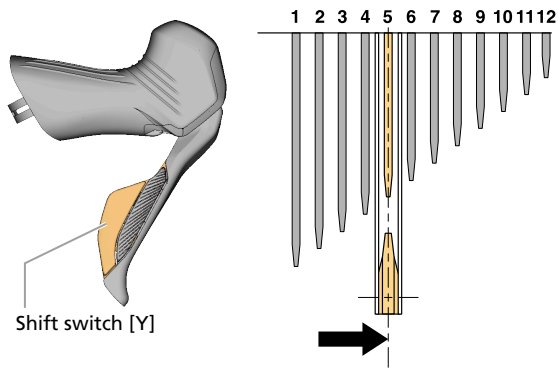

5. Switch the gear shifting system back to normal mode.

Press and hold the function button. (0.5 seconds or more)

After pressing and holding down the function button, the LED will light up blue or flash blue to indicate the shift mode currently selected, then turn off.

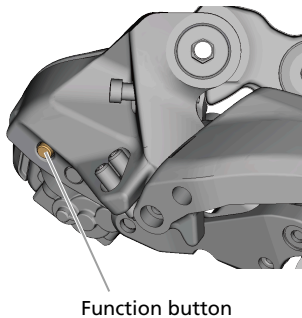

6. Shift to each gear and check that no noise is generated at any sprocket position.

If fine adjustment is needed, switch back to adjustment mode and readjust the rear derailleur.

If shifting is not possible for some gears even after adjustment, refer to "[Troubleshooting](#)."

Adjusting the low/high limits



NOTICE

- The following issues may occur if the low/high limits are not properly adjusted:
 - Shifting to the smallest or largest sprocket is not possible. Even if the gears are shifted, the gear may shift back by 1 gear after approximately 5 seconds.
 - Gear shifting noise does not stop.
 - The battery level drops quickly because an undue load is being placed on the motor.
 - The motor may be damaged due to overload (irreparable).
 - The chain will become derailed from the sprocket and damage the rear derailleur, wheel, frame, etc.

1. Adjust the low limit.

- (1) Shift the rear derailleur to the largest sprocket.
- (2) Tighten the low limit screw until it just touches the low limit stopper.

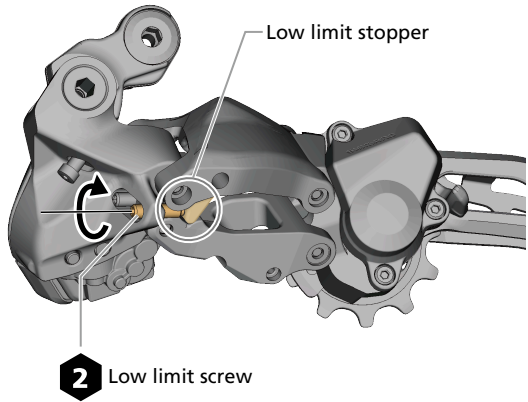

2. Adjust the high limit.

- (1) Shift the rear derailleur to the smallest sprocket.
- (2) Tighten the high limit screw until it just touches the high limit stopper.
- (3) Turn the high limit screw counterclockwise one turn from position (2) so that an over-stroke allowance can be maintained.

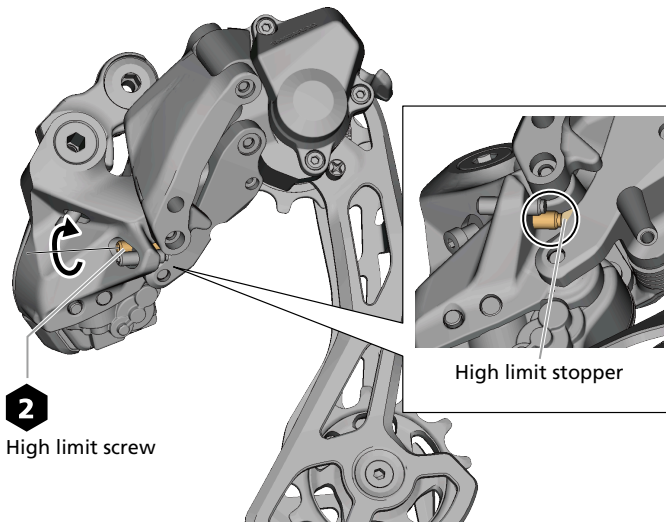

TECH TIPS

- During gear shifting, the rear derailleur may temporarily move to a position other than the target position. This operation ensures accurate gear shifting, and the rear derailleur will stop at the target position after the operation is complete.

Connection and communication with devices

E-TUBE PROJECT

Connecting the bicycle to a device allows you to update the settings and firmware, and more.

E-TUBE PROJECT is needed to configure the settings and update firmware.

Download E-TUBE PROJECT from our support website (<https://bike.shimano.com/e-tube/project.html>).

For information on how to install E-TUBE PROJECT, check the support website.

NOTICE

- If your version of E-TUBE PROJECT and the firmware for each component are not up to date, there could be problems operating the bicycle. Check the version and update them to the latest ones.

TECH TIPS

- The SM-PCE02 can be used to connect the entire bicycle to a PC.
- E-TUBE PROJECT Cyclist may be used if a Bluetooth[®] LE connection is established with a smartphone.
- Firmware is subject to change without notice.

Items configurable in E-TUBE PROJECT

Display settings	Display time setting	Sets the time until the display turns off when the display monitor is left unattended.
Switch function setting		Modify the shift switch function settings.
Shift mode setting		Modify the shift mode (synchronized shift) settings.
Multi-shift mode setting	Multi-shifting mode ON/OFF	Select whether or not to use multi-shifting.
	Gear-shifting interval	Sets the gear-shifting interval for multi-shifting.
	Gear number limit	Sets the limit on the number of gears shifted when the shift switch is pressed and held.
System pairing settings		Performs system pairing (wireless) by reading a QR code or entering a serial code.

Wireless function

A D-FLY compatible cycle computer is required to establish communication between the rear derailleur and the cycle computer. The types of information displayed on the cycle computer vary by product. For details, refer to the owner's manual for the cycle computer.

Function

The rear derailleur transmits the following three types of information to cycle computers or receivers via Bluetooth[®] LE connection or ANT[®] connection:

- Gear position information (front and rear)
- Di2 battery level information
- Adjustment mode information

The types of information displayed on the receiving side differ depending on the model of cycle computer.

Shift mode setting (synchronized shift)

The shift mode can be set in E-TUBE PROJECT to maintain the ideal front and rear gear positions by synchronizing the shifting between the front and rear derailleurs.

- Up to two shift modes can be set in E-TUBE PROJECT. For the setting procedure, refer to the [user's manual for E-TUBE PROJECT](#).
- The shift mode can be switched by double-clicking the function button on the rear derailleur. For details, refer to "[Switching operation modes.](#)"

Semi-synchronized shift

The rear derailleur automatically shifts gears in synchronization with front derailleur gear shifting. The rear derailleur can be set to automatically shift from 0 to 4 gears. 2 gear positions is the default. The options for the number of automatic shifts may vary depending on the combination of cassette and chainrings used.

When shifting from the largest chainring to the smallest chainring

The rear derailleur shifts from 0 to 4 gears outward. 2 gear positions is the default.

Front shifting functionality

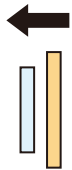

Rear synchronization shift

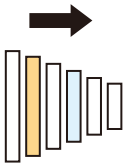

When shifting from the smallest chainring to the largest chainring

The rear derailleur shifts from 0 to 4 gears inward. 2 gear positions is the default.

Front shifting functionality

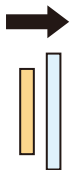

Rear synchronization shift

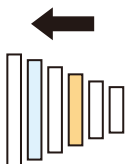

Synchronized shift

The front derailleur automatically shifts gears in synchronization with rear derailleur gear shifting. The switching gear position for synchronized shift is configured as shown in the figure by default.

Gear position (cassette)		Smallest chainring (inner)	Largest chainring (outer)
Largest sprocket (low)	1		
	2		
	3		
	4		
	5		
	6		
	7		
	8		
	9		
	10		
	11		
Smallest sprocket (top)	12		

↓ : Shifting up ↑ : Shifting down ■ : Combination with unused gear

The figure shows the following operations following rear gear shifting.

- Shifting up: When the front is on the smallest chainring and the rear is shifted up to 7th gear, the following operation is performed.
 - The front automatically switches to the largest chainring.
 - The rear also automatically switches to 5th gear.
- Shifting down: When the front is on the largest chainring and the rear is shifted down to 2nd gear, the following operation is performed.
 - The front automatically switches to the smallest chainring.
 - The rear also automatically switches to 4th gear.

Maintenance

Replacing the pulleys

1. Replace the guide pulley/tension pulley.

When installing the pulleys, check the direction of the arrows on them (the rotation direction of the pulleys when the crank is turned in the forward direction).

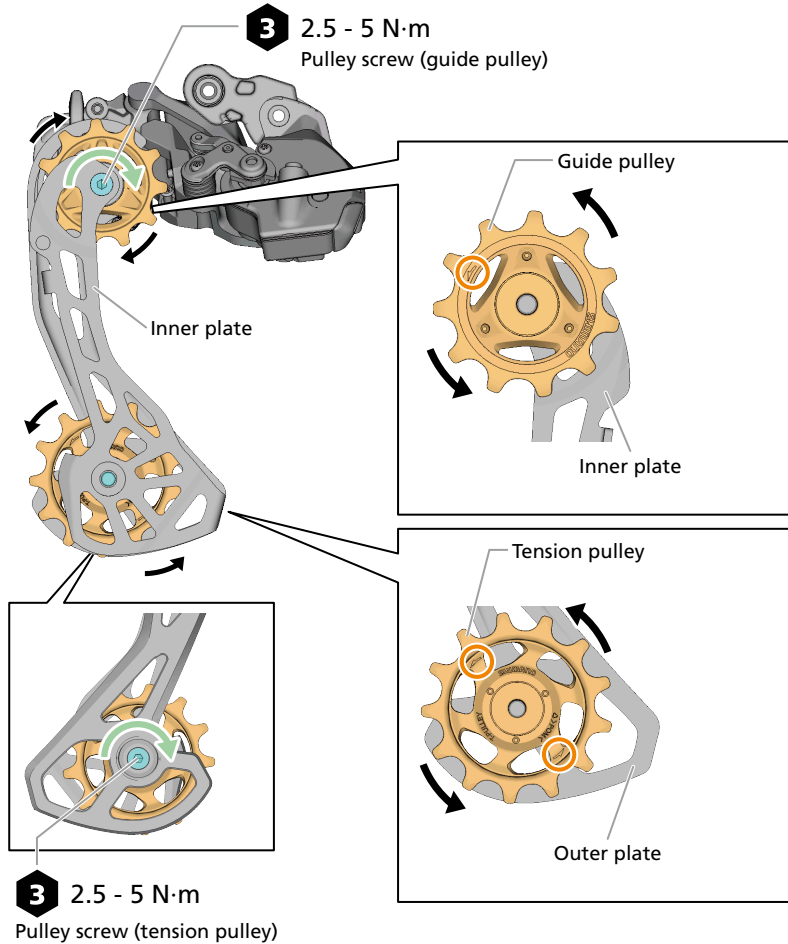

Applying grease to the chain stabilizer

If there is a noticeable change in friction in the chain stabilizer assembly, or if it starts to make noise, you may need to add grease to the chain stabilizer.

* When assembling, reverse the procedure.

1. Set the switch lever in the OFF position.

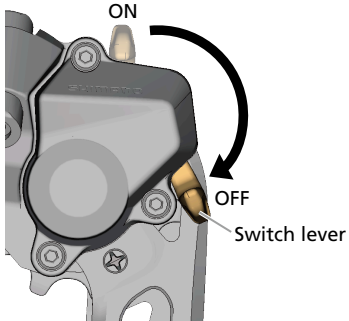

2. Remove the plate unit cover.

When assembling, tighten the plate unit cover screws with a torque of 1 - 1.5 N·m.

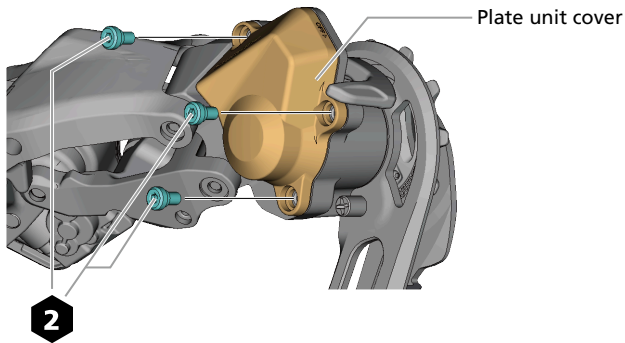

3. Remove the chain stabilizer and cam unit together.

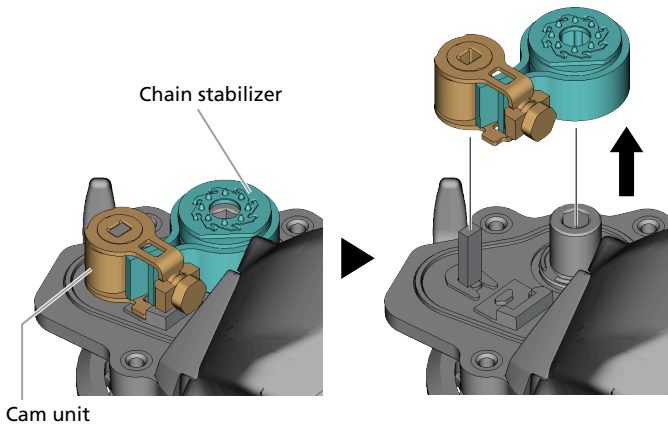

4. Apply the dedicated grease to the outer diameter surface of the roller clutch.

Maintenance

Applying grease to the chain stabilizer

SHADOW RD+ Grease number: Y04121000
(50 g)



Roller clutch

NOTICE

- Be careful not to get grease inside the roller clutch. Otherwise, the clutch could stick, slip, or otherwise malfunction.

Adjusting friction

The level of friction can be adjusted as desired. Furthermore, the friction can also be adjusted when it changes during use.

1. Set the switch lever in the OFF position.

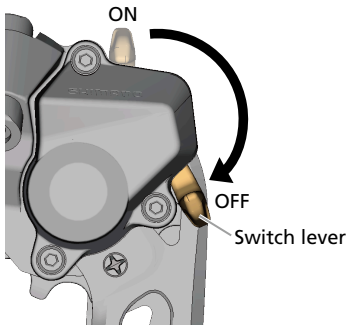

2. Remove the plate unit cover.

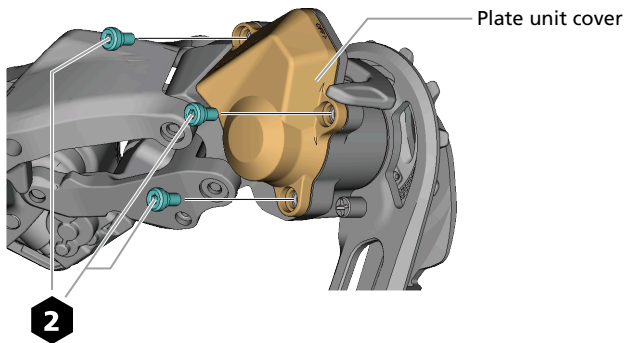

3. Turn the friction adjustment screw to adjust the friction.

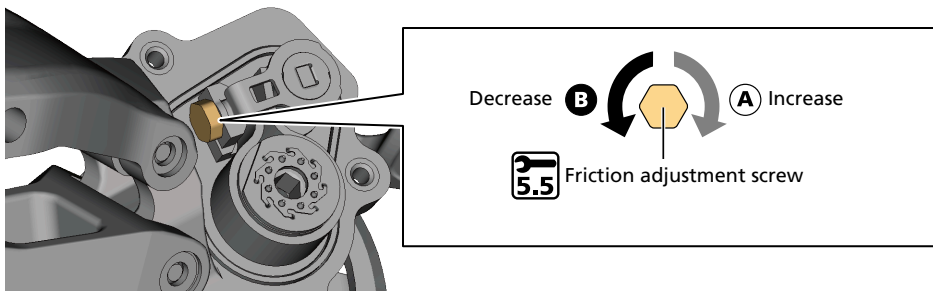

NOTICE

- Do not adjust the friction with a torque of 0.25 N·m or higher. Turning the screw excessively may cause damage.

4. Check the friction torque.

Use your finger to hold the cam unit securely in place, then set the switch lever to the ON position and check the friction torque.

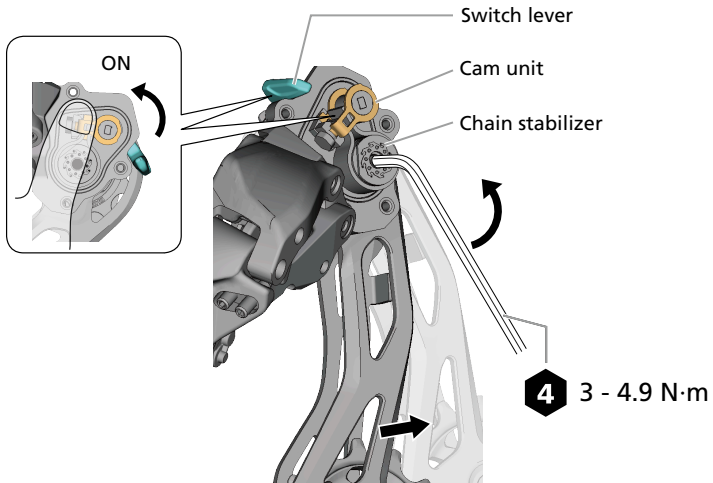

NOTICE

- If adjusting the friction once more, be sure to set the switch lever to the OFF position while pressing the cam unit with your finger before making the adjustment.

5. Set the switch lever in the OFF position.

Set the switch lever to the OFF position while pressing the cam unit with your finger. At that time, make sure that the cam unit is in contact with the bottom of the plate unit.

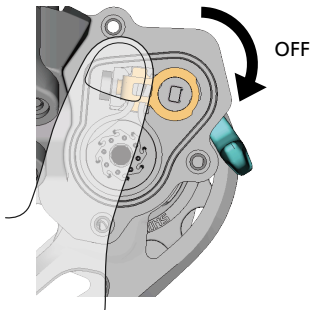

NOTICE

- Do not install the plate unit cover if the switch base is not in proper contact with the plate unit. This may result in insufficient sealing, which can lead to corrosion and malfunction of the chain stabilizer assembly.

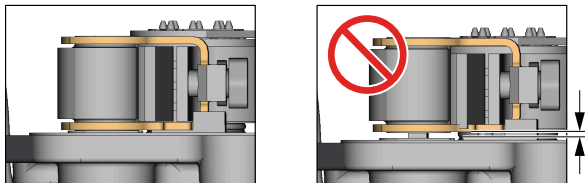

6. Install the plate unit cover.

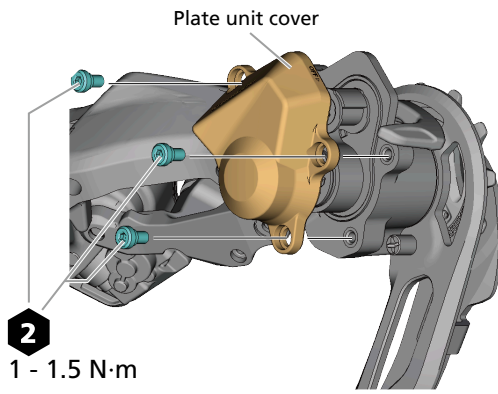

Removing the plate, P-tension spring, and switch lever

Before replacing the plate or P-tension spring, remove the rear wheel and chain, and shift the rear derailleur to the low side (largest sprocket) position.

1. Set the switch lever in the OFF position.

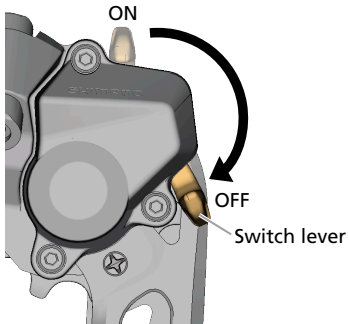

NOTICE

- If operating the switch lever while the plate unit cover is removed, hold the cam unit down with your finger so that it does not slide out.

2. Remove the plate stopper pin.

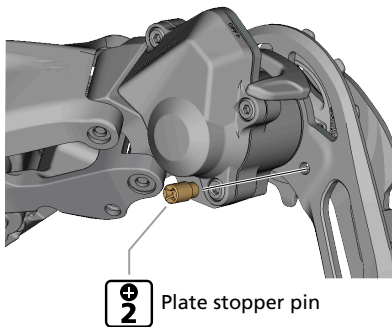

NOTICE

- Hold the plate and rear derailleur body firmly when working, as there is spring force applied to the plate.

3. Turn the plate to loosen the P-tension spring.

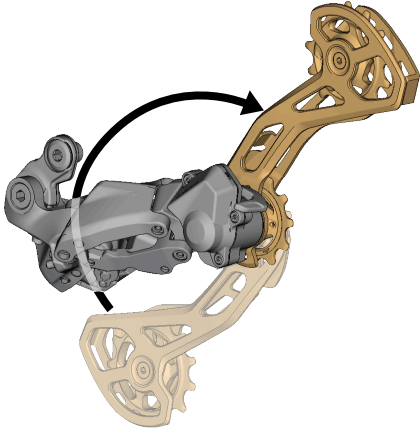

4. Remove the plate unit cover screws.

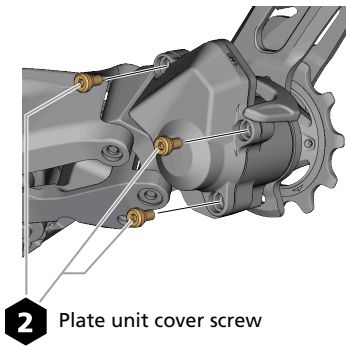

2 Plate unit cover screw

5. Remove the plate unit cover.

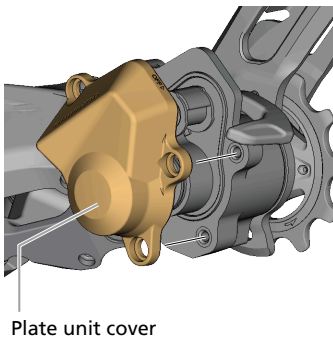
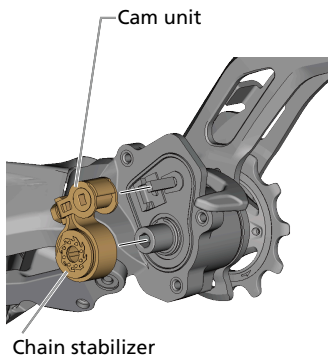

Plate unit cover

6. Remove the chain stabilizer and cam unit.



Chain stabilizer

7. Remove the plate axle.

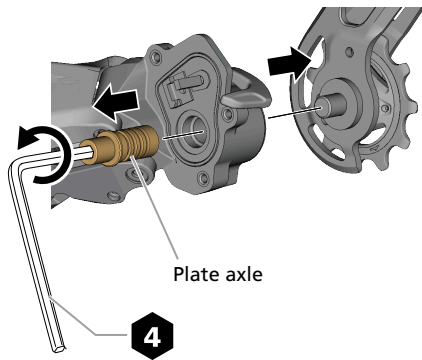

8. Remove the retaining clip and switch lever.

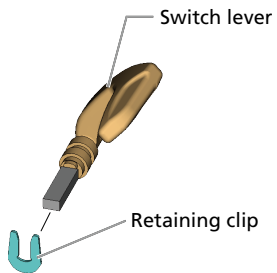
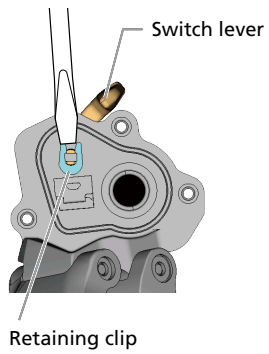

Installing the plate, P-tension spring, and switch lever

When removing it, reverse the procedure.

1. Apply the dedicated grease to the plate axle.

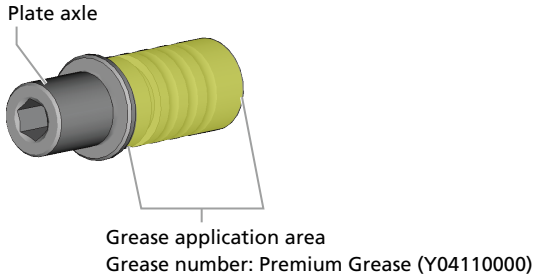

NOTICE

- Do not apply grease outside of the application area indicated above. If grease is applied here, it will get inside the roller clutch and friction will be lost.

2. Install the switch lever and engage the retaining clip.

Set the switch lever in the OFF position.

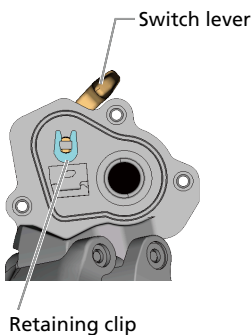

3. Insert the plate axle, then fit the tip of the P-tension spring in the hole of the plate.

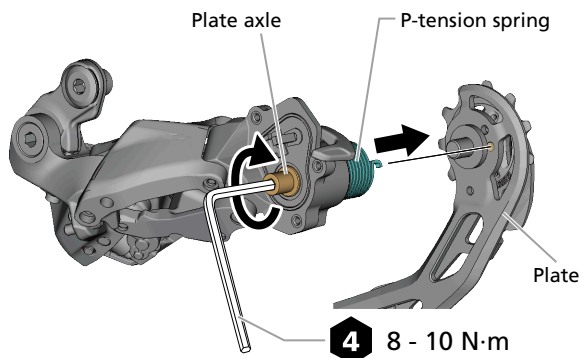

4. Set the chain stabilizer into the cam unit as shown in the figure.

Check that the cam lobe of the cam unit is in the position shown in the figure.

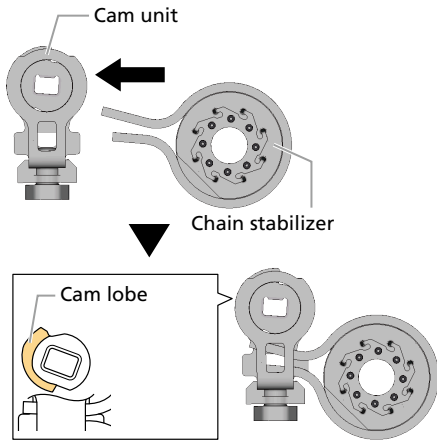

NOTICE

- Ensure the cam unit is installed with the cam lobe in the correct position. Do not install it in the position shown in this figure.

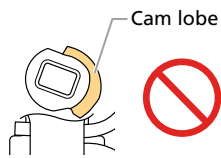

5. Install the cam unit and chain stabilizer.

Pay attention to the positioning of the cam lobe of the cam unit.

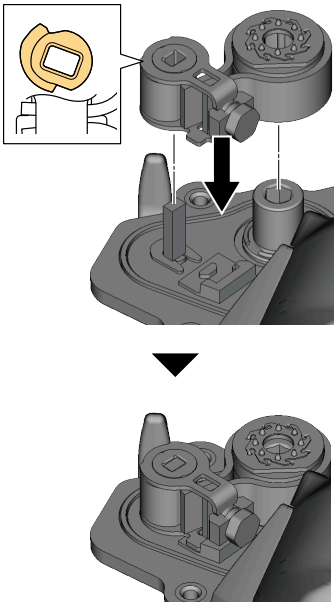

NOTICE

- Do not install the plate unit cover if the plate unit is not fully seated against the cam unit. This may result in insufficient sealing, which can lead to corrosion and malfunction of the chain stabilizer assembly.

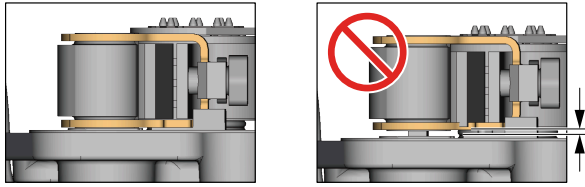

TECH TIPS

- When installing, it helps to move the plate back and forth while pushing on the cam unit and chain stabilizer.

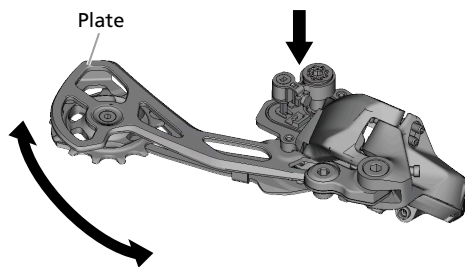

- If there is resistance when moving the switch lever to the ON position, the components are installed correctly. If there is no resistance, check the position of the cam lobe of the cam unit and reinstall the components.

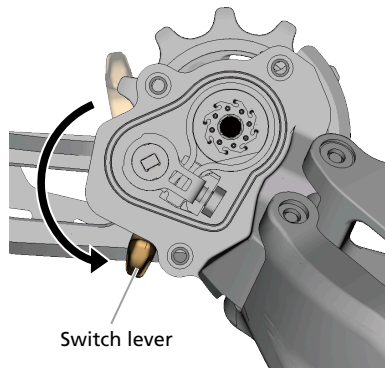

6. Install the plate unit cover gasket.

Check that it is installed along the groove in the plate unit.

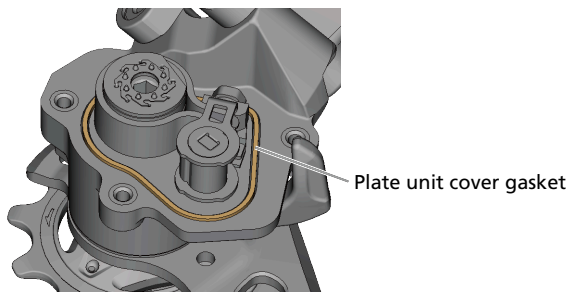

7. Install the plate unit cover.

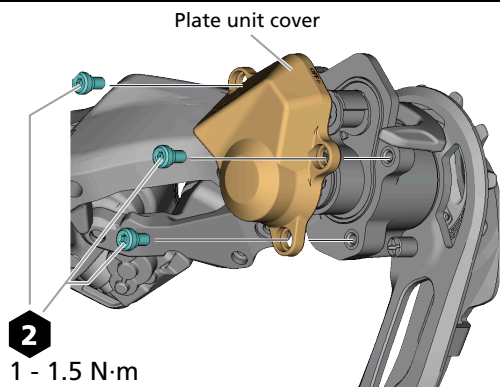

8. Twist the plate and install the plate stopper pin.

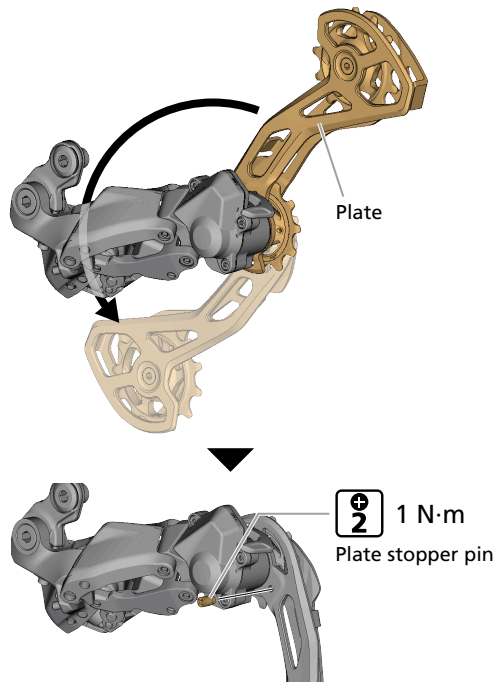

NOTICE

- Hold the plate and rear derailleur body firmly when working, as there will be spring force applied to the plate.

9. Check the friction, and adjust as necessary.

Refer to " [Adjusting friction](#) " for the friction adjustment method.

Replacing the charging port cover

1. Remove the charging port cover.

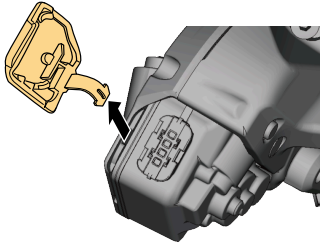

2. Replace with a new charging port cover.

As shown in the figure, push it in with your fingers.

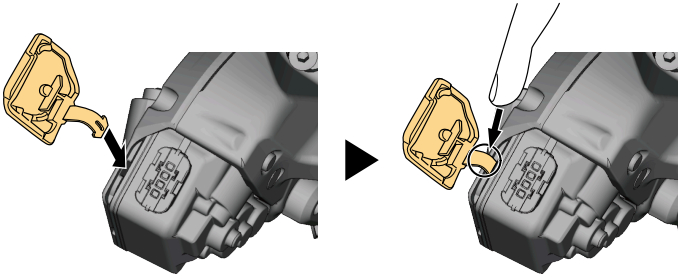

Troubleshooting

When a problem occurs

Check the following information if you have a problem with the rear derailleur.

If the problem is not covered below or cannot be solved with the indicated method, contact a distributor.

Symptoms	Causes/possibilities	Remedies
Gear shifting is not performed.	Is the pairing correct?	Perform system pairing with a wired or wireless connection. ⇒ “ System pairing (wired) ” ⇒ “ System pairing (wireless) ”
	Is there sufficient charge remaining in the battery?	Charge the battery and check again. ⇒ “ Charging method ”
	Is the battery charging?	Gear shifting is disabled when charging the battery. Remove the charging cable and try again.
	Have 30 minutes or more elapsed since the last gear shift when using the shift switch wirelessly?	Operate the shift switch to shift the gear again.
	Has the RD protection function operated?	While turning the crank arm, operate the shift switch so that the gear is shifted from the largest sprocket to the smallest sprocket. ⇒ “ RD protection reset ”
No gear shifting is performed.	The gear shifting position may be misaligned.	Use E-TUBE PROJECT Professional to conduct an error check. Refer to “ Error check ” in the E-TUBE PROJECT Professional User's Manual.
Cannot charge.	Is the electric wire connected securely?	Connect the electric wire securely, and charge the battery again. If charging is still not performed, check whether the electric wire is damaged.
	Is the connection terminal of the electric wire clean?	Wipe the connection terminals clean with a dry cloth, then charge again. If it still does not charge, contact a distributor.
	Is the system connected to E-TUBE PROJECT?	Disconnect E-TUBE PROJECT and connect the charging cable again.
	The battery may have reached the end of its life.	Replace the battery with a new one.

Troubleshooting
When a problem occurs

Symptoms	Causes/possibilities	Remedies
The LED does not light up when the charging cable is connected.	Is the battery fully charged?	The rear derailleur LED lamp turns off when the battery is fully charged, but this is normal. Remove and reconnect the power plug of the AC adapter, then charge again. If the rear derailleur LED lamp still does not light up, contact the distributor.
The rear derailleur and battery become abnormally hot when charging.	The temperature of the battery and rear derailleur may exceed the operating temperature.	When charging the battery, approximately 12°C above the ambient temperature is the normal range. If the battery becomes abnormally hot, stop charging and wait until the battery and rear derailleur cool down, then charge again. If the symptom still persists, contact the distributor for assistance.
	Have multiple batteries been charged in succession?	The rear derailleur may become hot when charging multiple batteries in succession. Wait for the rear derailleur to cool down between charges.
The LED flashes red while charging.	The current may be insufficient for charging.	Use an AC adapter with a current capacity higher than 1.0 A. If you are using a USB hub, reconnect the charging cable to the AC adapter directly.
The LED flashes red while pairing.	Are you using a compatible product?	Check whether the shift switch supports wireless communication. If the product is compatible, check the battery level and perform pairing again. If pairing still fails, contact a distributor. ⇒ " Compatibility " ⇒ " LED display "
The LED lights red.	The battery level may be too low to perform operations.	Charge the battery and check again. If the problem is not resolved, contact the distributor. ⇒ " Charging method "

SHIMANO

SHIMANO NORTH AMERICA BICYCLE, INC.

One Holland, Irvine, California 92618, U.S.A. Phone: +1-949-951-5003

SHIMANO EUROPE B.V.

High Tech Campus 92, 5656 AG Eindhoven, The Netherlands Phone: +31-402-612222

SHIMANO INC.

3-77 Oimatsu-cho, Sakai-ku, Sakai City, Osaka 590-8577, Japan

Please note: specifications are subject to change for improvement without notice. (English)

© May 2024 by SHIMANO INC. ITP