

Dealer's Manual

ROAD	GRAVEL	MTB
E-BIKE	LIFESTYLE	GENERAL

Rear Derailleur

GRX

RD-RX820

RD-RX822

Contents

IMPORTANT NOTICE	3
TO ENSURE SAFETY	4
List of tools to be used	7
Installation/removal	8
Installing the rear derailleur	8
Adjustment	13
Adjusting the stroke on the high limit	13
Checking the chain length	13
Installing the chain	16
Connection and securing of the inner cable	17
Adjusting the stroke on the low limit	22
Adjusting the B-screw	22
SIS adjustment.....	25
Maintenance	28
Replacing the pulleys.....	29
Replacing the mounting screw (RD-RX822)	31
Replacing the bumper (RD-RX822)	32
Applying grease to the chain stabilizer	33
Adjusting friction	34
Removing the plate, plate tension spring, and switch lever	39
Installing the plate, plate tension spring, and switch lever	42



IMPORTANT NOTICE

- This dealer's manual is intended primarily for use by professional bicycle mechanics.
Users who are not professionally trained for bicycle assembly should not attempt to install the components themselves using the dealer's manuals.
If any part of the information on the manual is unclear to you, do not proceed with the installation. Instead, contact your place of purchase or a distributor for assistance.
- Make sure to read all manuals included with each product.
- Do not disassemble or modify the product other than as stated in the information contained in this dealer's manual.
- All manuals and technical documents are accessible online at <https://si.shimano.com> .
- For consumers who do not have easy access to the internet, please contact a SHIMANO distributor or any of the SHIMANO offices to obtain a hardcopy of the user's manual.
- Please observe the appropriate rules and regulations of the country, state or region in which you conduct your business as a dealer.

For safety, be sure to read this dealer's manual thoroughly before use, and follow it for correct use.

The following instructions must be observed at all times in order to prevent personal injury and physical damage to equipment and surroundings.

The instructions are classified according to the degree of danger or damage which may occur if the product is used incorrectly.

 DANGER	Failure to follow the instructions will result in death or serious injury.
 WARNING	Failure to follow the instructions could result in death or serious injury.
 CAUTION	Failure to follow the instructions could cause personal injury or physical damage to equipment and surroundings.

TO ENSURE SAFETY

WARNING

- Be sure to follow the instructions provided in the manuals when installing the product.
Only use SHIMANO genuine parts. If a component or replacement part is incorrectly assembled or adjusted, it can lead to component failure and cause the rider to lose control and crash.
-  Wear approved eye protection while performing maintenance tasks such as replacing components.

Be sure to also inform users of the following:

- Clean the chain and QUICK-LINK with an appropriate chain cleaner regularly. Intervals between maintenance depend on the use and riding circumstances. Never use alkali- or acid-based solvents such as rust cleaners. If those solvents are used the chain or QUICK-LINK might break and cause serious injury.
- Check the chain for any damage (deformation or cracking), skipping, or other abnormalities such as unintended gear shifting. The chain may break, and you may fall. If any problems are found, consult your place of purchase or a distributor.

■ When using TL-CT12

- Be careful not to get injured by the blade or needle while working.
- Be careful not to get your fingers pinched by the tool while working.
- Keep the tool out of the reach of small children.

NOTICE

Be sure to also inform users of the following:

- For SHADOW RD+, be sure to check that the plate unit cover and the plate unit rubber cap are installed before riding the bicycle.
- If gear shifting operation does not feel smooth, consult the place of purchase for assistance.
- The gears should be periodically washed with a neutral detergent then lubricated. In addition, cleaning the chain and QUICK-LINK with a neutral detergent and lubricating them can be an effective way of extending the life of the chain and QUICK-LINK.
- Products are not guaranteed against natural wear and deterioration from normal use and aging.
- For maximum performance we highly recommend SHIMANO lubricants and maintenance products.

For installation to the bicycle and maintenance

- Depending on the shape of the frame, the rear derailleur may interfere with the chainstay. Use the B-screw to adjust so that the rear derailleur does not interfere with the chainstay.
- Grease with SIS SP41 Grease (Y04180000) the inner cable and the sliding portions of the outer casing before use to ensure that they slide properly. Do not let dust adhere to the inner cable.
- To ensure smooth operation, use OT-RS900 outer casing for rear derailleur and a cable guide.
- Use an outer casing which still has some length to spare even when the handlebars are turned all the way to either side. Furthermore, check that the shifter does not touch the bicycle frame when the handlebars are turned all the way.
- The end of the outer casing which has the sealed outer cap (aluminum type) should be on the shifting unit side. Refer to the ST-RX820 dealer's manual for details.

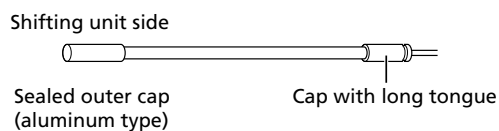









- If gear shifting adjustments cannot be carried out, check the alignment of the derailleur hanger and check if the cable is lubricated or if the outer casing is too long or too short.
- Periodically clean the shifting unit and lubricate all moving parts (mechanism and pulleys).
- Some pulleys have arrows on them to indicate the direction of rotation. In that case, install the pulley so that the rotation direction of the pulley matches the direction of the arrows when the crank is turned in the forward direction.
- If you hear abnormal noise as a result of excess play in a pulley, you should replace the pulley.

The actual product may differ from the illustration because this manual is

intended mainly to explain the procedures for using the product.

List of tools to be used

The following tools are needed for installation/removal, adjustment, and maintenance purposes.

Tool	
	2 mm hexagon wrench
	3 mm hexagon wrench
	4 mm hexagon wrench
	5 mm hexagon wrench
	5.5 mm spanner
	Hexalobular [#27]
	Cross head screwdriver [#2]
	TL-CT12

Installation/removal

Installing the rear derailleur

TECH TIPS

- The rear derailleur will not gear shift properly if the derailleur hanger is not straight. Use TL-RD11 to check whether the derailleur hanger is straight or not.
- It is recommended to move the switch lever to the ON position while riding to reduce chain slap and to help prevent the chain from falling off the sprockets.

Standard type

1. Set the switch lever in the OFF position.

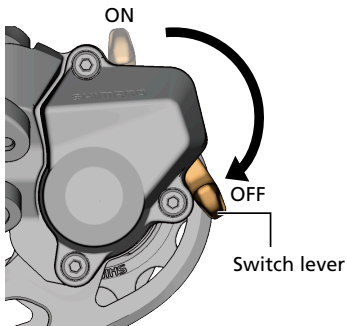

2. Install the rear derailleur.

Be careful not to insert the mounting screw in the derailleur hanger at an angle.

In addition, be sure to install the rear derailleur so that the stopper plate contacts the B-tension stop, with no gap in between.

RD-RX820

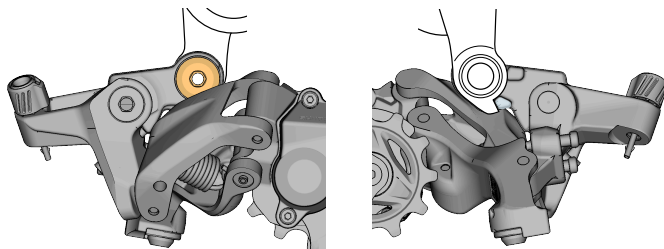
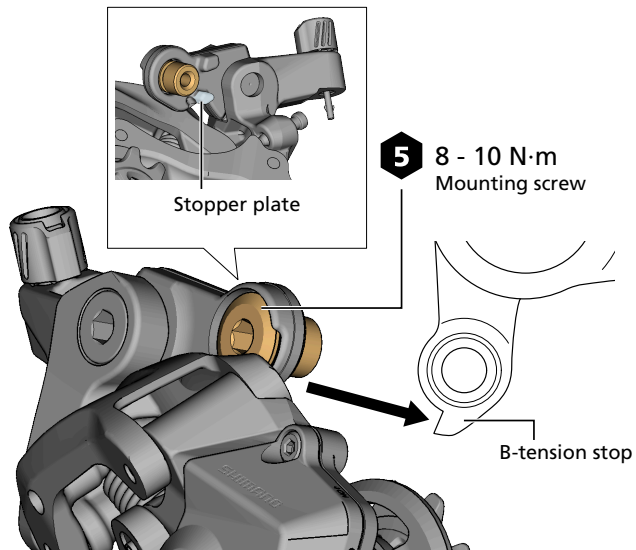

RD-RX822

Installation/removal

Installing the rear derailleur

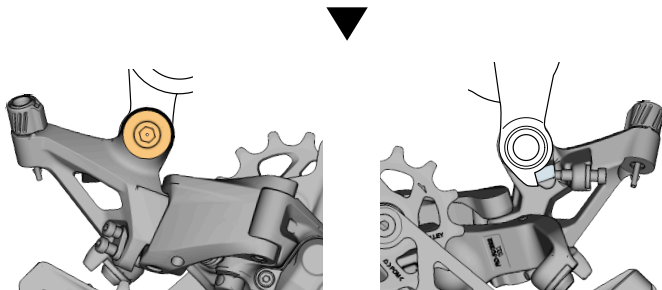
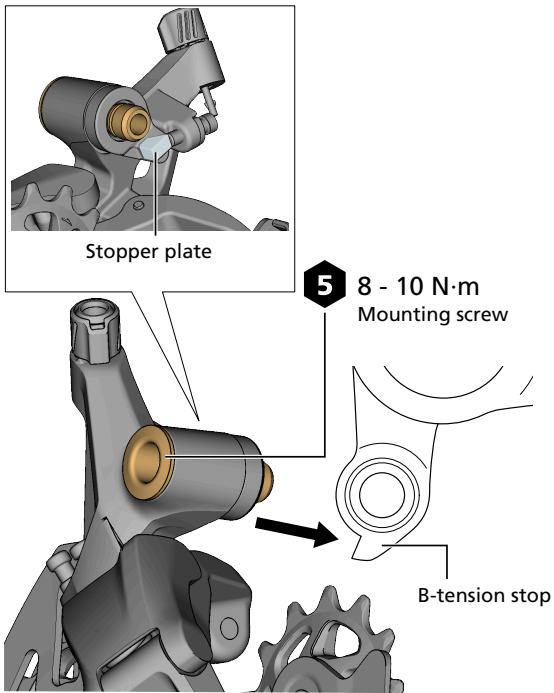

NOTICE

- Periodically check to make sure that there is no gap between the B-tension stop and the stopper plate. If there is a gap between these two parts, problems with gear shifting performance may occur.

RD-RX820

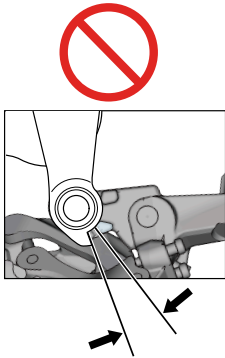

RD-RX822

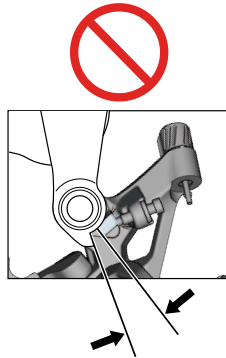

Direct mount type (RD-RX820)

- Set the switch lever in the OFF position.

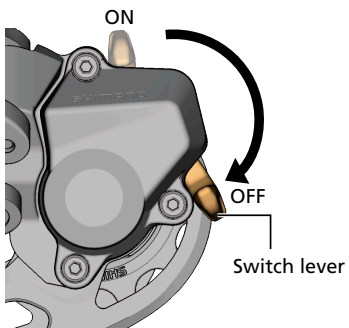

Installation/removal

Installing the rear derailleur

2. Remove the bracket axle plate.

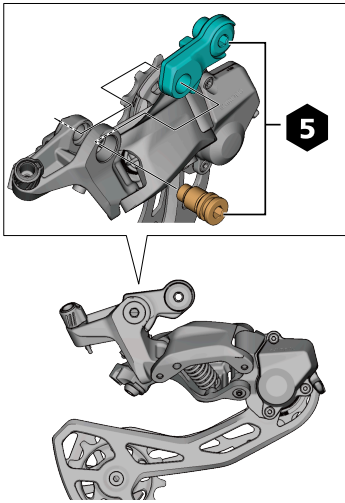

3. Install the rear derailleur.

- (1) Insert the derailleur hanger into the installation part for direct mount of the rear derailleur.
- (2) Install the rear derailleur with the bracket axle.

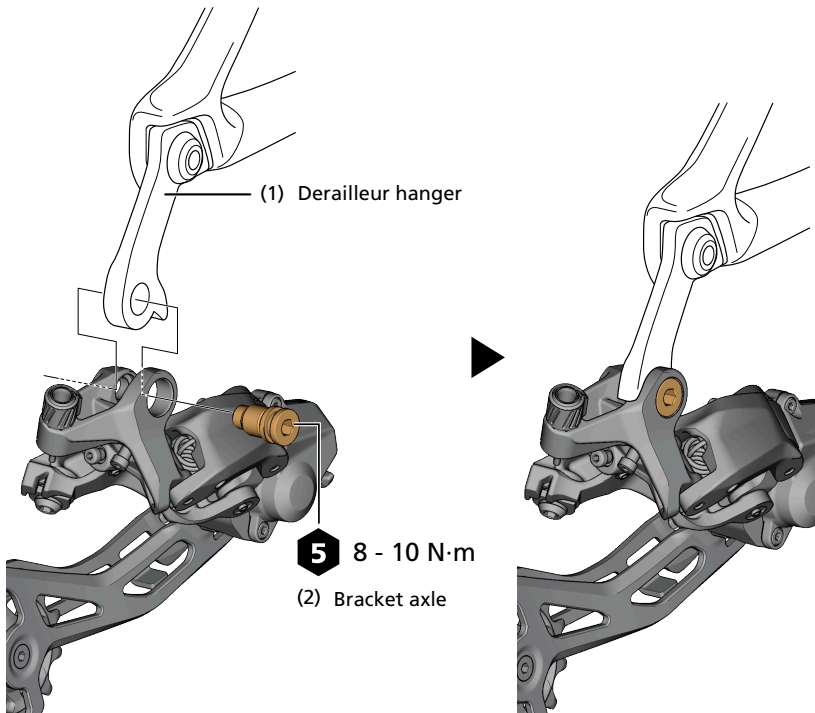

Adjustment

Adjusting the stroke on the high limit

1. Adjust by turning the high limit screw.

Adjust so that the center of the guide pulley is aligned with the outer face of the smallest sprocket when viewed from the rear side.

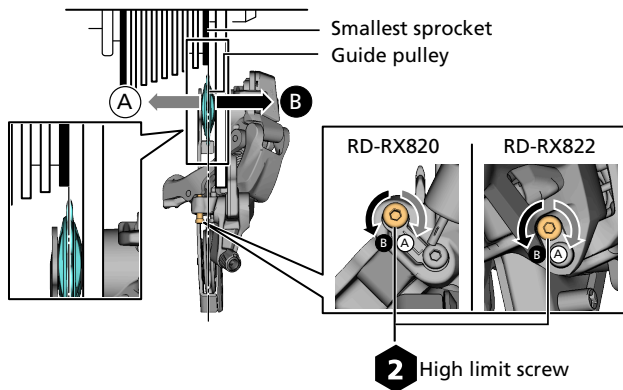

Checking the chain length

1. Mount the chain on the largest sprocket and the largest chainring.

In order to check the length at the rear of the cassette, join the two ends of the chain at the rear of the cassette as shown in the figure.

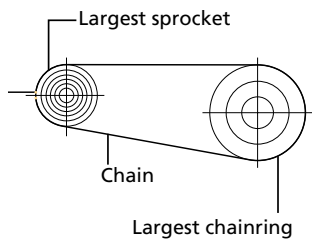

Adjustment

Checking the chain length

2. Check the length of the chain.

With the zero point of the chain established on the rear of the largest sprocket, the proper final chain length is determined by adding a certain amount of links to this resulting chain length. The amount of links is dependent on the model.

RD-RX820

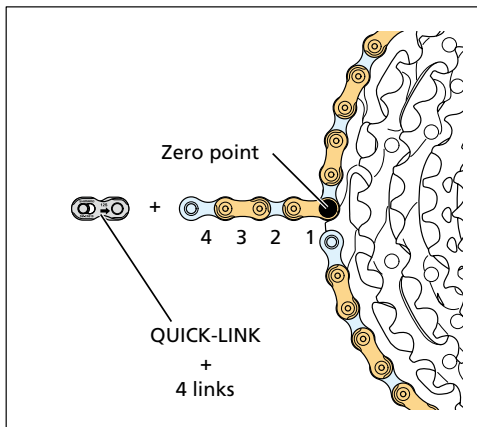
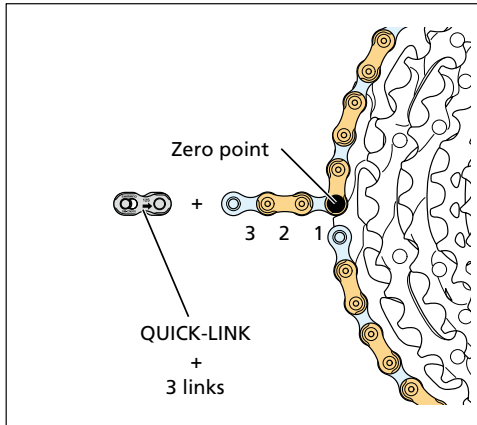

RD-RX822

Adjustment

Checking the chain length

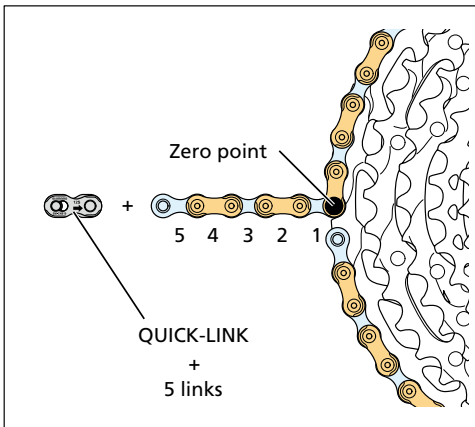
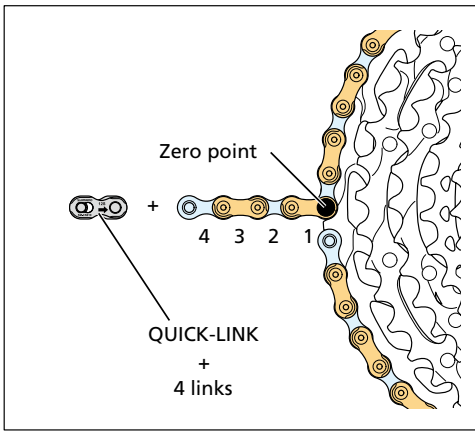

NOTICE

- The rear derailleur plate assembly is equipped with a pin or plate that prevents chain derailment. When routing the chain through the rear derailleur, route it so that it is on the rear derailleur body side of the chain derailment prevention plate, as shown in the figure. If the chain is not passed through the correct position, damage may be caused to the chain or the rear derailleur.

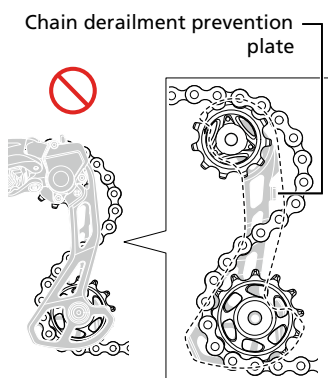
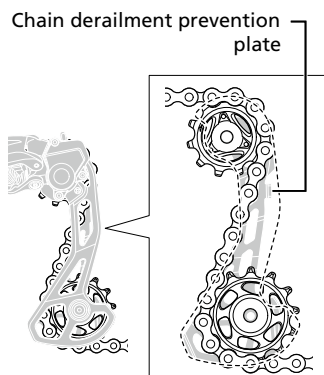

Installing the chain

Refer to the dealer's manual for the chain to find instructions on installing/removing the chain.

Connection and securing of the inner cable

Outer casing length

1. Loosen the B-screw to the position shown in the figure.

Make sure that the stopper plate touches the bracket body without leaving a gap.

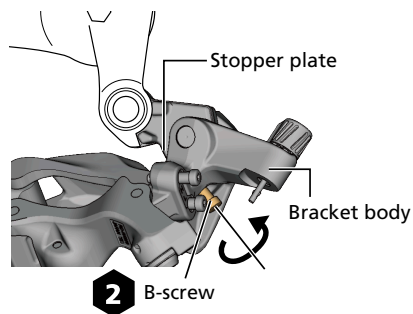

2. Determine the length of the outer casing.

Attach a sealed outer cap to the end of the outer casing. Align the end of the outer cap to the bottom edge of the outer casing holder on the rear derailleur.

Make sure to leave enough slack in the outer casing.

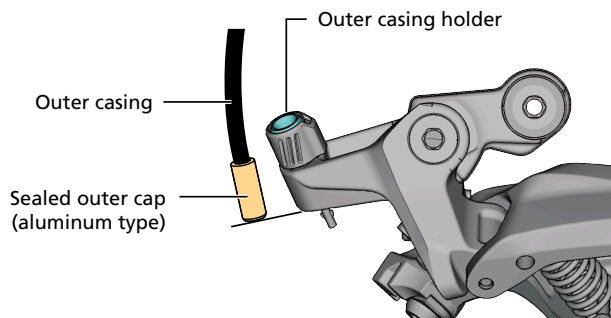

NOTICE

- Make sure to use OT-RS900 for the outer casing.

Adjustment

Connection and securing of the inner cable

3. Cut off any excess outer casing.

Cut the end of the outer casing that is opposite to the marking.

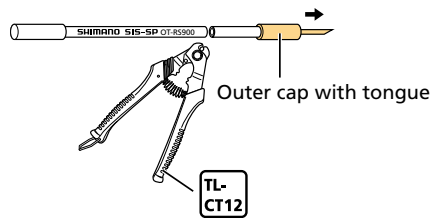

4. Remove the outer cap with tongue from the cut outer casing.



5. Spread out the tip of the liner using a thin tool such as a TL-CT12 needle.

Arrange the cut end into a perfect circle.

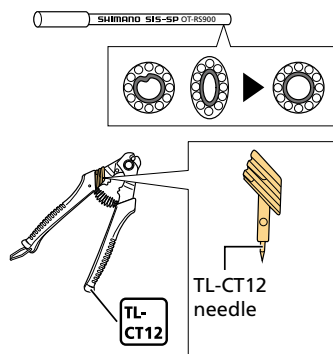

NOTICE

- Be careful not to hurt your hands with the TL-CT12 needle.

Adjustment

Connection and securing of the inner cable

6. Install the cap with long tongue to the end.

The end of the outer casing which has the sealed outer cap (aluminum type) should be on the shifting unit side.

Route the inner cable through the outer casing.

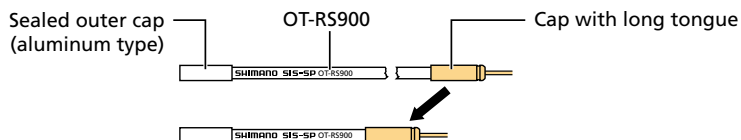

Connection and securing of the inner cable

⚠ CAUTION

- Do not allow the wheel to turn while securing the inner cable and installing the inner end cap. Otherwise, you may touch the wheel and be injured.

1. Set the shifter in its initial position.

Operate the release lever 11 times or more.

2. Secure the inner cable to the rear derailleur.

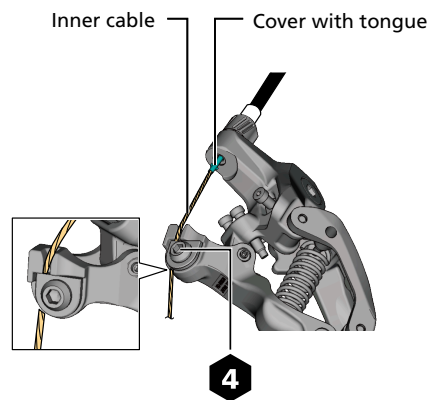

NOTICE

- Replacing the cover with tongue is recommended when replacing the inner cable.
- Cables with a polymer coating may develop a fuzzy appearance or texture through natural wear when used. However, if the cables are installed with care according to the procedures outlined in this manual, this is strictly cosmetic and performance will not be affected where the inner cables are housed by outer casing.

3. Remove the initial slack from the inner cable.

Hold the rear derailleur so that it won't move under load from the shift cable. Operate the shifter several times in order to tension the shift cable assembly and fully seat all the shift cable components.

4. Re-secure the inner cable to the rear derailleur.

While pulling the inner cable, be sure that it is securely in the cable fixing groove.

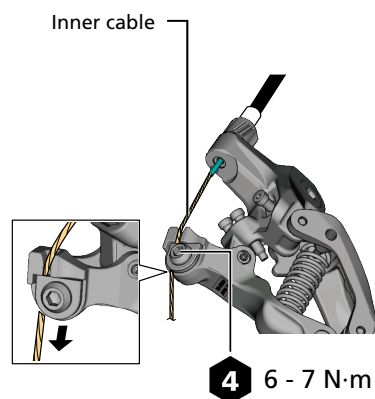

Adjustment

Connection and securing of the inner cable

5. Cut the inner cable so that the protruding length is approximately 30 mm.

Install the inner end cap.

RD-RX820

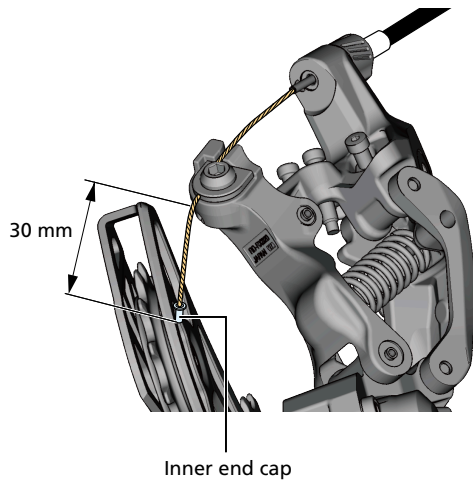

RD-RX822

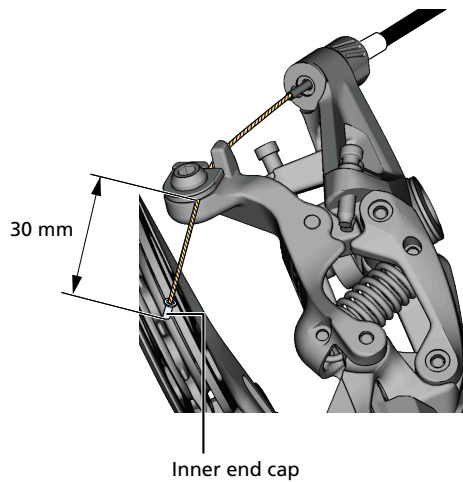

NOTICE

- Check that the inner cable does not interfere with the spokes of the wheel.
- Do not allow the wheel to turn while carrying out this step.

Adjusting the stroke on the low limit

NOTICE

- If the B-screw is loose when adjusting the stroke on the low limit, the largest sprocket and chain may interfere. Before adjusting the stroke on the low limit, tighten the B-screw to some extent to open a gap between the largest sprocket and guide pulley.

1. Adjust by turning the low limit screw.

Align the center of the guide pulley with the center of the largest sprocket while moving the guide pulley using the shifter, etc.

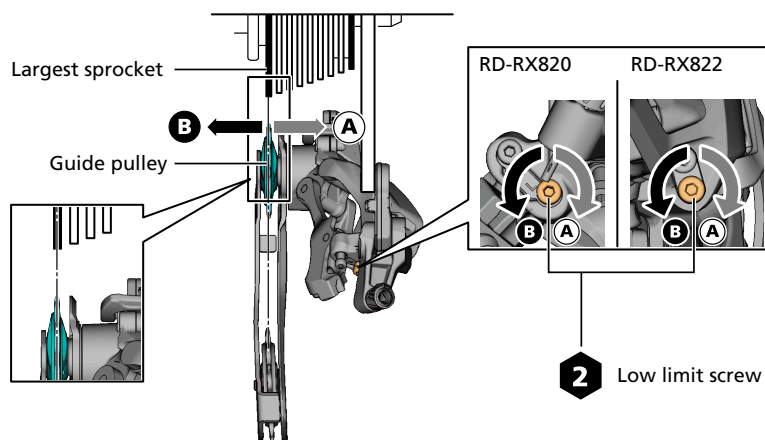

Adjusting the B-screw

RD-RX820

1. Shift the chain to the smallest chainring and the largest sprocket.

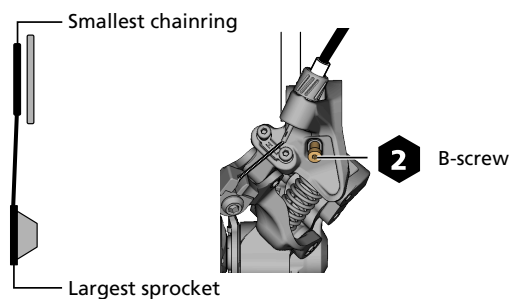

Adjustment

Adjusting the B-screw

2. Adjust the B-screw.

Adjust the gap between the largest sprocket and the guide pulley to the distance indicated in the table.

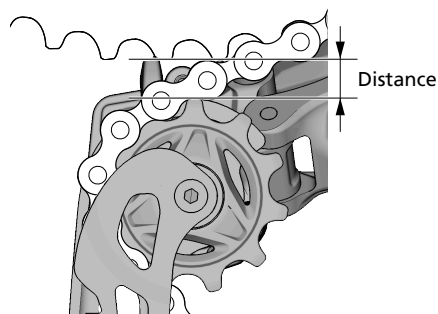

Cassette	Distance between largest sprocket and guide pulley
11-34T	10 mm
11-36T	6 mm

TECH TIPS

- The B-screw can also be adjusted using the included G-pulley setting tool. Set the G-pulley setting tool on the plate as shown in the figure, and align the tip of the largest sprocket with the line of the G-pulley setting tool using the B-screw.

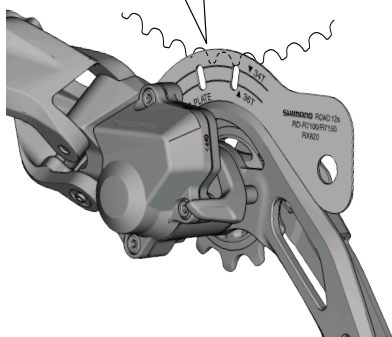
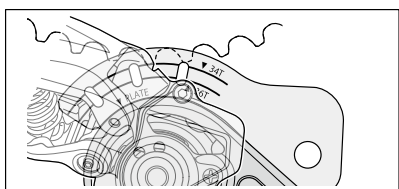

- G-pulley setting tools differ depending on the model. Use the G-pulley setting tool upon confirming the models listed on it.

Adjustment

Adjusting the B-screw

3. Turn the crank arm to shift gears and ensure that the shift is smooth.

NOTICE

- Perform this adjustment again when using a cassette with a different number of teeth.

RD-RX822

1. Shift the chain to the largest sprocket.

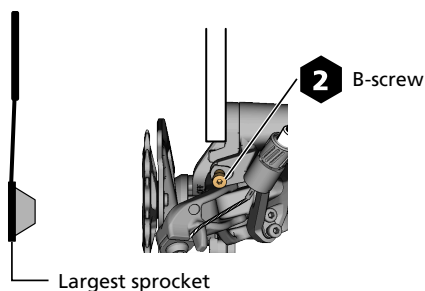

2. Adjust the B-screw.

Adjust it to one of the following settings based on the combination of products being used.

RD-RX822-SGS

Align the line on the inner side of the outer plate with the tip of the highest tooth on the largest sprocket.

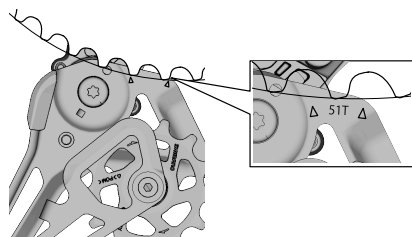

RD-RX822-GS

Align the contour of the outer plate with the tip of the highest tooth on the largest sprocket.

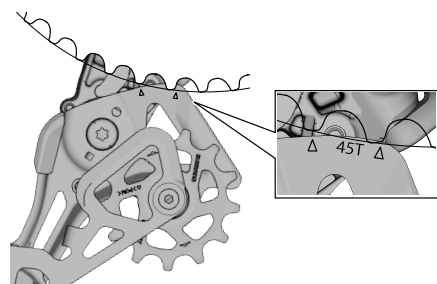

3. Turn the crank arm to shift gears and ensure that the shift is smooth.

NOTICE

- Perform this adjustment again when using a cassette with a different number of teeth.

SIS adjustment

1. Set the switch lever in the OFF position.

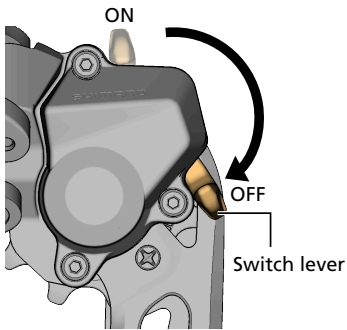

2. Operate the shifter several times to shift the chain to the fifth gear from the largest sprocket.
For bicycles with double front chainrings, shift to the largest chainring.

NOTICE

- If the chain rubs against the larger adjacent sprocket and makes noise while turning the crank, turn the cable adjustment barrel clockwise until there is no noise.

Adjustment

SIS adjustment

3. Turn the cable adjustment barrel counterclockwise while turning the crank until you start to hear the chain rub on the larger sprocket.

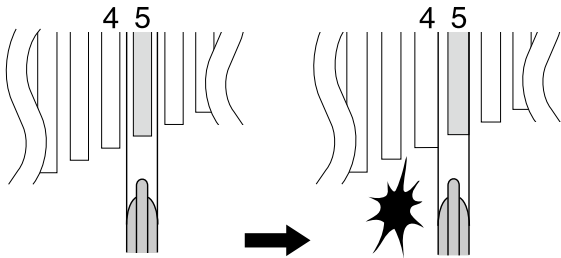
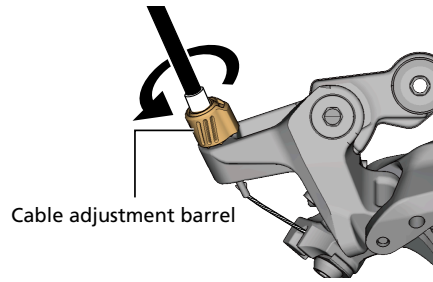

4. Turn the cable adjustment barrel five clicks in the clockwise direction. This position will serve as the target for adjustment.

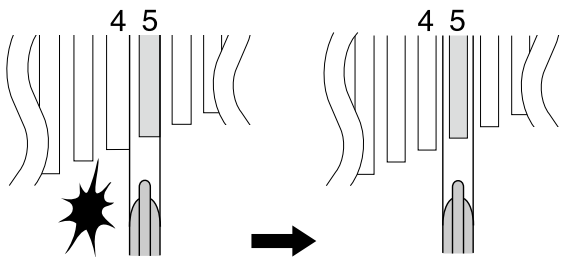
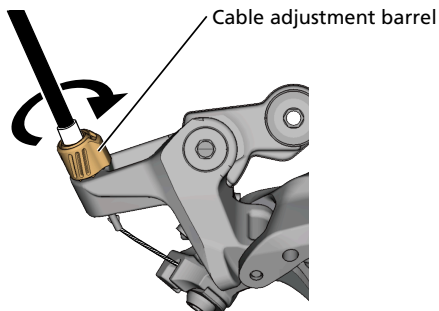

5. **Operate the shifter to change gears while turning the crank, and check that no noise occurs in any of the gear positions.**

If the chain makes noise, readjust from step 2 .

TECH TIPS

- The rear derailleur will not gear shift properly if the derailleur hanger is not straight. Use TL-RD11 to check whether the derailleur hanger is straight or not.

6. **Set the switch lever in the ON position and check that the gear shifting is smooth, consistent, and that there is no noise in any of the gear positions while riding the bicycle.**

Maintenance

Replacing the pulleys

1. Replace the guide pulley/tension pulley.

When installing the pulleys, check the direction of the arrows on them (the rotation direction of the pulleys when the crank is turned in the forward direction).

RD-RX820

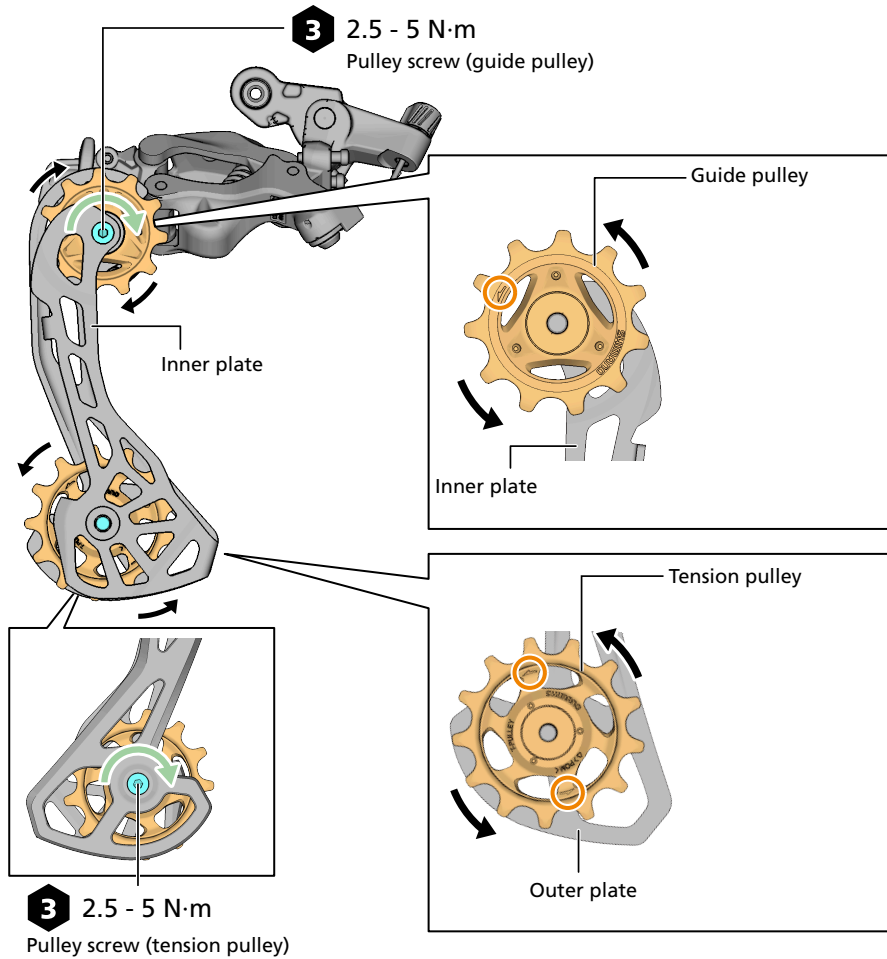

RD-RX822

Replacing the mounting screw (RD-RX822)

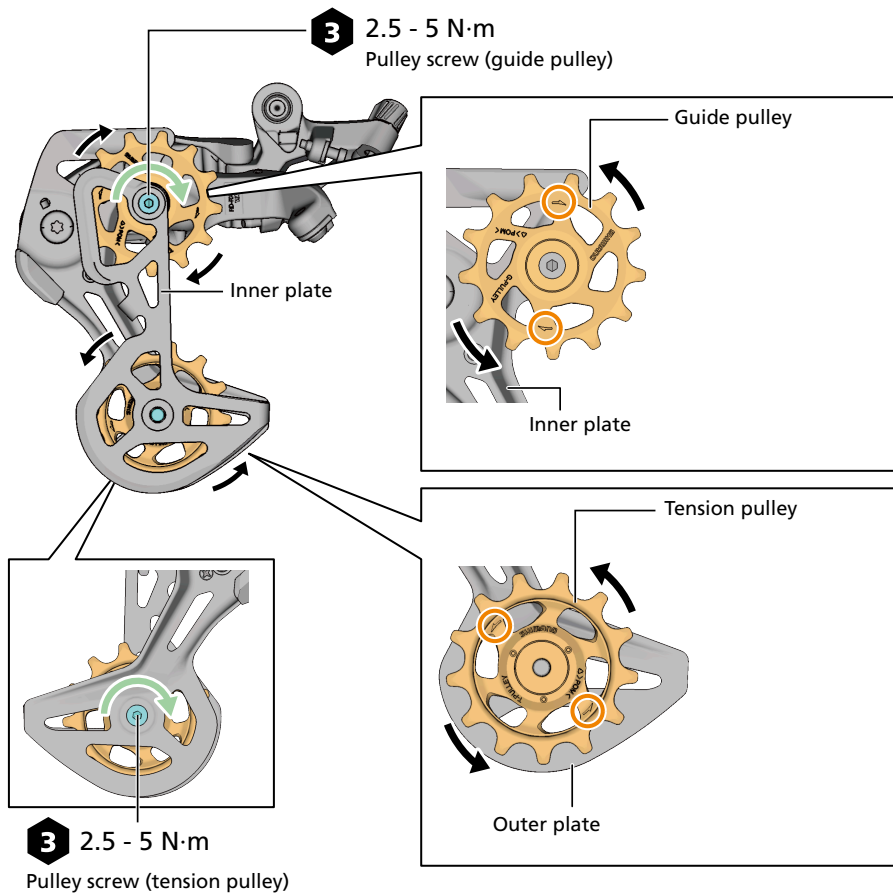

NOTICE

- The pulleys have arrows on them to indicate the direction of rotation. Install the pulleys so that the rotation directions of the pulleys match the directions of the arrows when the crank is turned in the forward direction.

Replacing the mounting screw (RD-RX822)

1. Push the mounting screw from the inner side and use a tool such as a slotted screwdriver to widen and remove the snap ring.

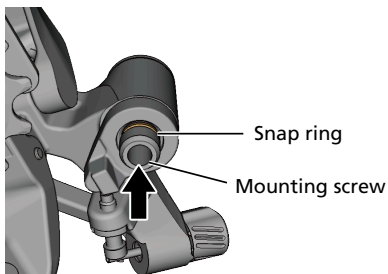

2. **Push the threaded portion of the mounting screw against the stopper plate and use the hexagon wrench to unthread the mounting screw from the stopper plate.**

Replace the mounting screw with a new one and install it in the reverse order from the removal procedure.

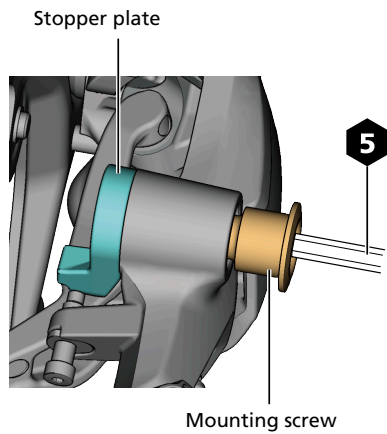

Replacing the bumper (RD-RX822)

1. **Remove the bumper so that it flips forward as shown in the figure.**

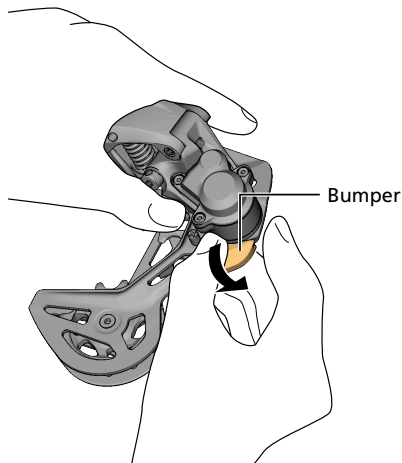

2. Install a new bumper by sliding it on from the side as shown in the figure.

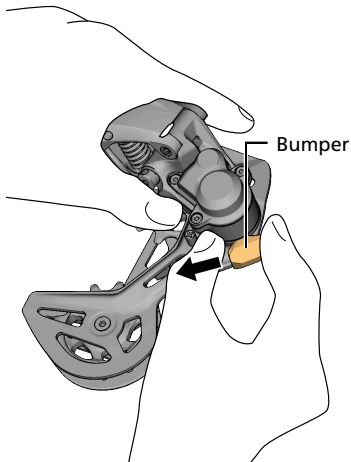

Applying grease to the chain stabilizer

If there is a noticeable change in friction in the chain stabilizer assembly, or if it starts to make noise, you may need to add grease to the chain stabilizer.

* When assembling, reverse the procedure.

1. Set the switch lever in the OFF position.

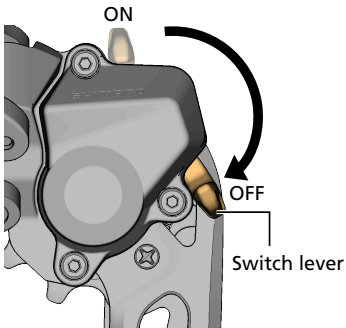

2. Remove the plate unit cover.

When assembling, tighten the mounting screws with a torque of 1 - 1.5 N·m.

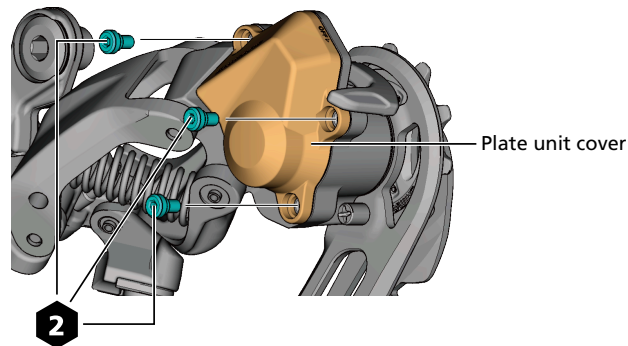

3. Remove the chain stabilizer and cam unit together.

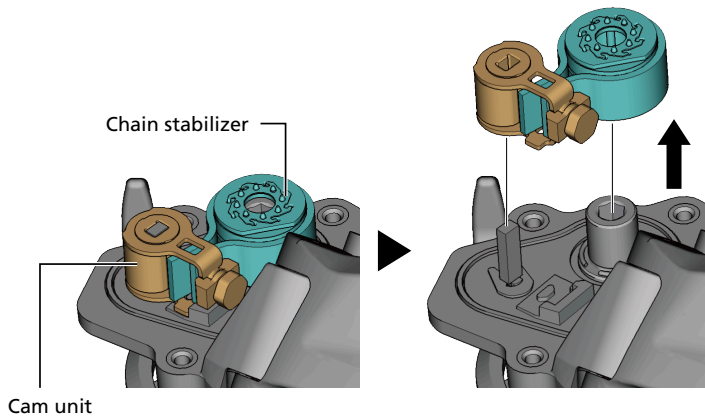

4. Apply the dedicated grease to the outer diameter surface of the roller clutch.

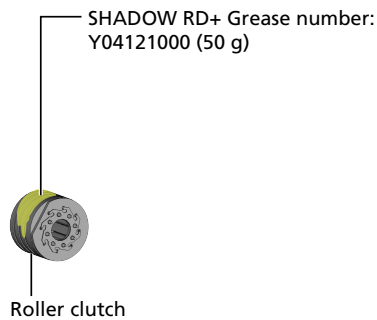

NOTICE

- Be careful not to get grease inside the roller clutch. Otherwise, the clutch could stick, slip, or otherwise malfunction.

Adjusting friction

The level of friction can be adjusted as desired. Furthermore, the friction can also be adjusted when it changes during use.

Maintenance

Adjusting friction

1. Set the switch lever in the OFF position.

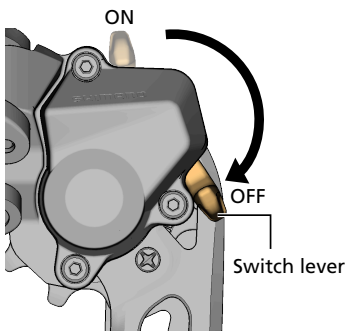

2. Remove the plate unit cover.

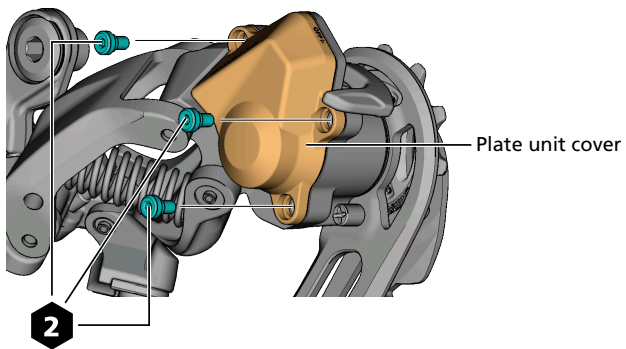

Maintenance

Adjusting friction

3. Turn the friction adjustment screw to adjust the friction.

RD-RX820

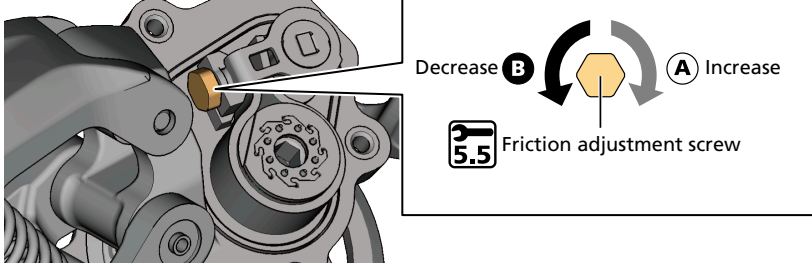

RD-RX822

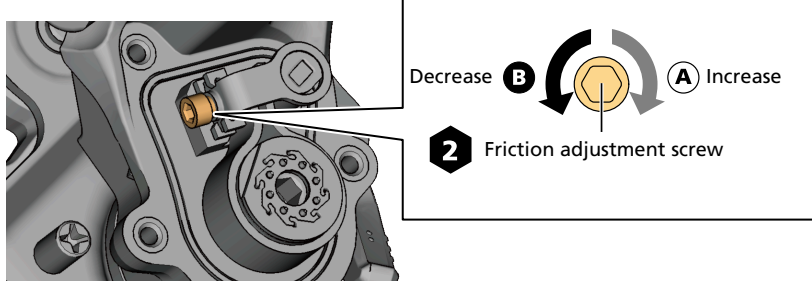

NOTICE

- Do not adjust the friction with a torque of 0.25 N·m or higher. Turning the screw excessively may cause damage.

4. Check the friction torque.

Use your finger to hold the cam unit securely in place, then set the switch lever to the ON position and check the friction torque.

RD-RX820

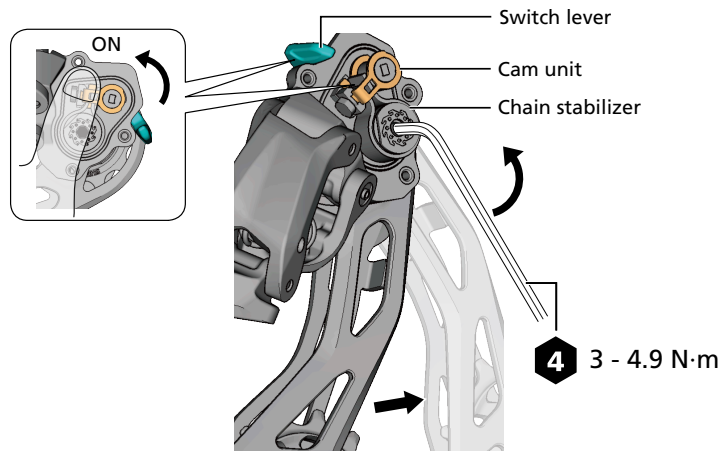

RD-RX822

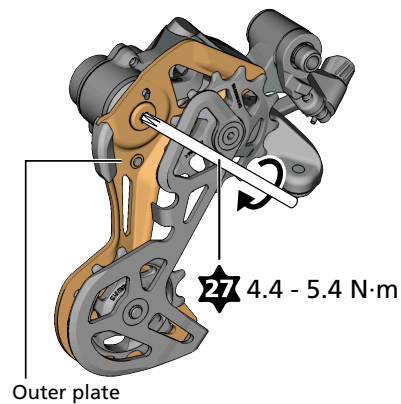

NOTICE

- If adjusting the friction once more, be sure to set the switch lever to the OFF position while pressing the cam unit with your finger before making the adjustment.

5. Set the switch lever in the OFF position.

Set the switch lever to the OFF position while pressing the cam unit with your finger. At that time, make sure that the cam unit is in contact with the bottom of the plate unit.

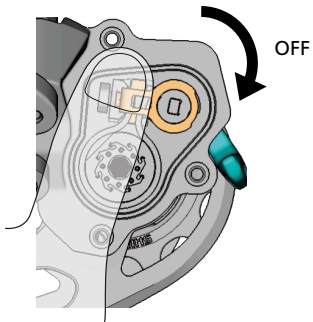

NOTICE

- Do not install the plate unit cover if the switch base is not in proper contact with the plate unit. This may result in insufficient sealing, which can lead to corrosion and malfunction of the chain stabilizer assembly.

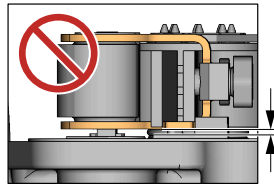
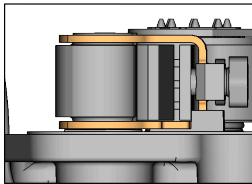

6. Install the plate unit cover.

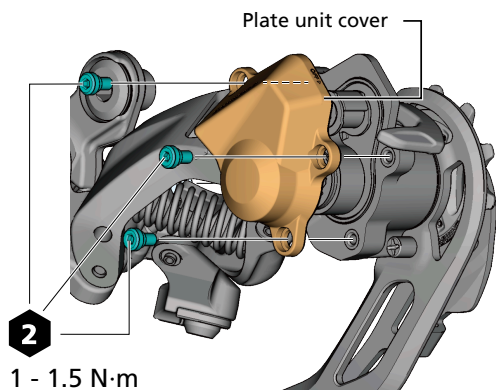

Removing the plate, plate tension spring, and switch lever

1. Set the switch lever in the OFF position.

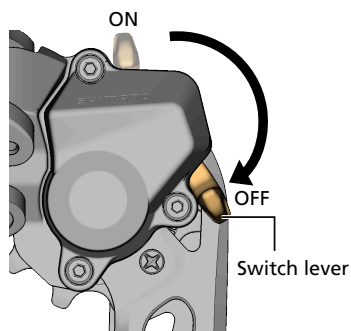

NOTICE

- If operating the switch lever while the plate unit cover is removed, hold the cam unit down with your finger so that it does not slide out.

2. Remove the plate stopper pin.

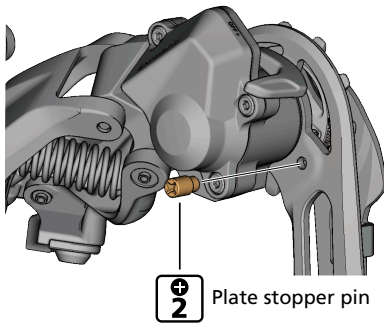

NOTICE

- Hold the plate and rear derailleur body firmly when working, as there is spring force applied to the plate.

3. Turn the plate to loosen the plate tension spring.

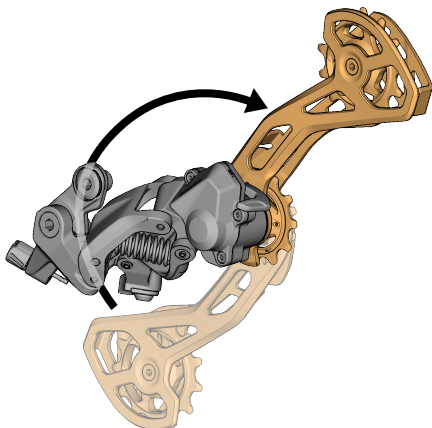

4. Remove the plate unit cover screws.

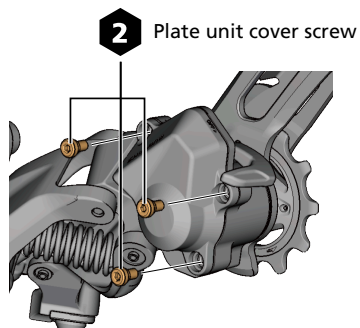

Maintenance

Removing the plate, plate tension spring, and switch lever

5. Remove the plate unit cover.

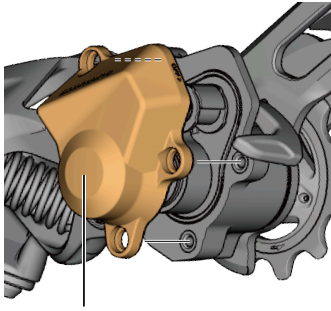
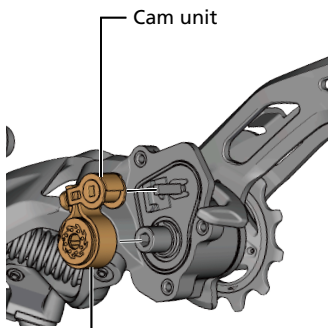

Plate unit cover

6. Remove the chain stabilizer and cam unit.



Chain stabilizer

7. Remove the plate axle.

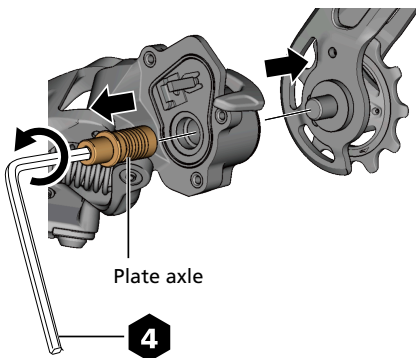
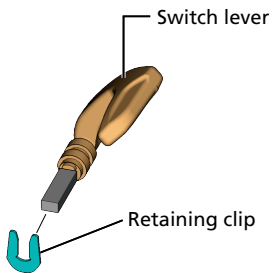
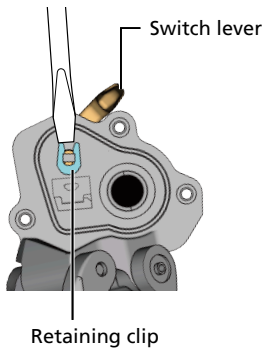

Plate axle

4

8. Remove the retaining clip and switch lever.



Installing the plate, plate tension spring, and switch lever

When removing it, reverse the procedure.

1. Apply the dedicated grease to the plate axle.

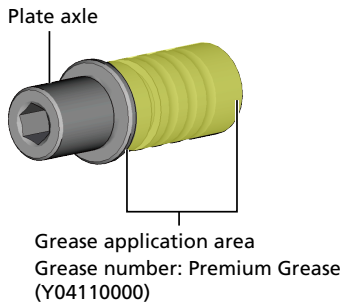

NOTICE

- Do not apply grease outside of the application area indicated above. If grease is applied here, it will get inside the roller clutch and friction will be lost.

Maintenance

Installing the plate, plate tension spring, and switch lever

2. Install the switch lever and engage the retaining clip.

Set the switch lever in the OFF position.

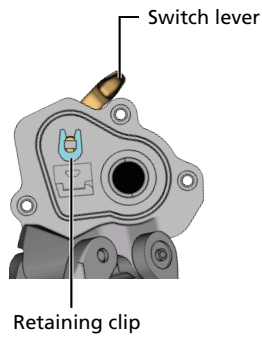

3. Insert the plate axle, then fit the tip of the plate tension spring in the hole of the plate.

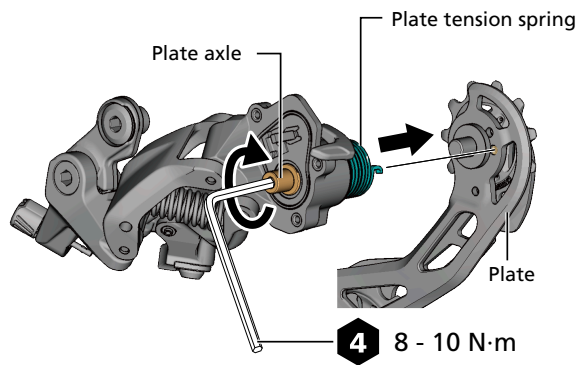

Maintenance

Installing the plate, plate tension spring, and switch lever

4. Set the chain stabilizer into the cam unit as shown in the figure.

Check that the cam lobe of the cam unit is in the position shown in the figure.

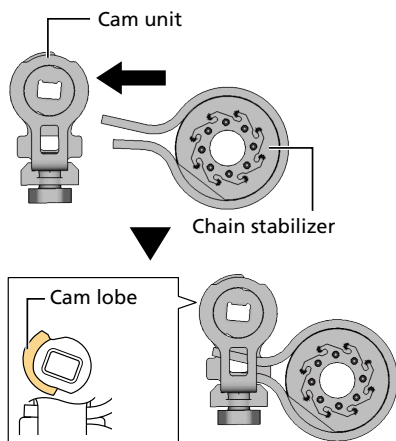

NOTICE

- Ensure the cam unit is installed with the cam lobe in the correct position. Do not install it in the position shown in this figure.

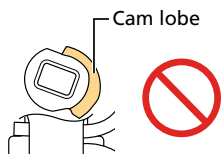

5. Install the cam unit and chain stabilizer.

Pay attention to the positioning of the cam lobe of the cam unit.

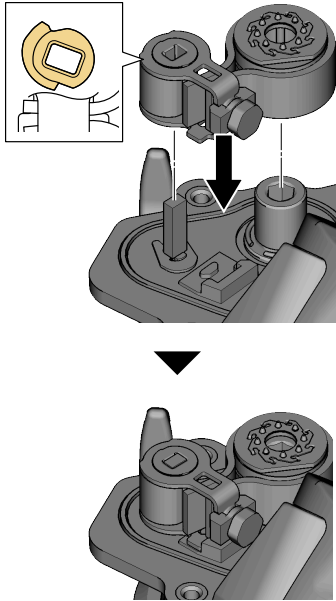

NOTICE

- Do not install the plate unit cover if the plate unit is not fully seated against the cam unit. This may result in insufficient sealing, which can lead to corrosion and malfunction of the chain stabilizer assembly.

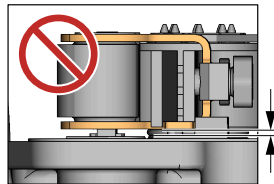
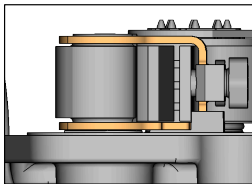

TECH TIPS

- When installing, it helps to move the plate back and forth while pushing on the cam unit and chain stabilizer.

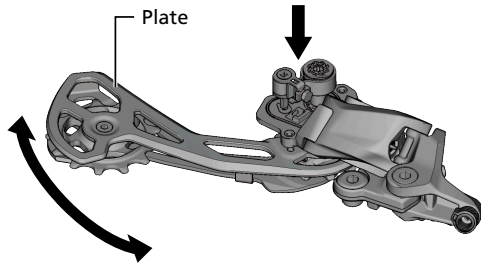

- If there is resistance when moving the switch lever to the ON position, the components are installed correctly. If there is no resistance, check the position of the cam lobe of the cam unit and reinstall the components.

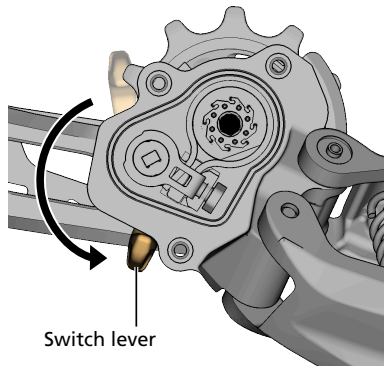

6. Install the plate unit cover gasket.

Check that it is installed along the groove in the plate unit.

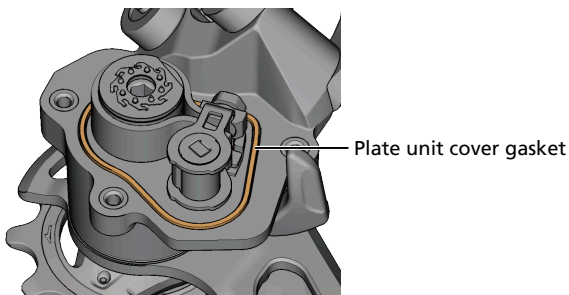

7. Install the plate unit cover.

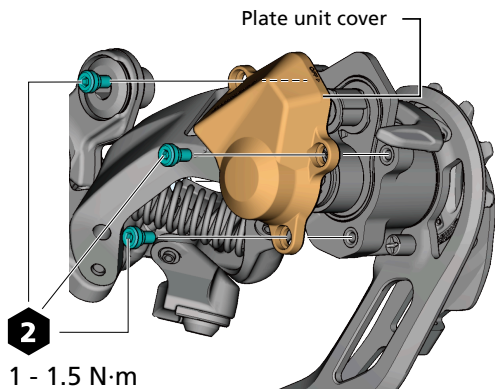

8. Twist the plate and install the plate stopper pin.

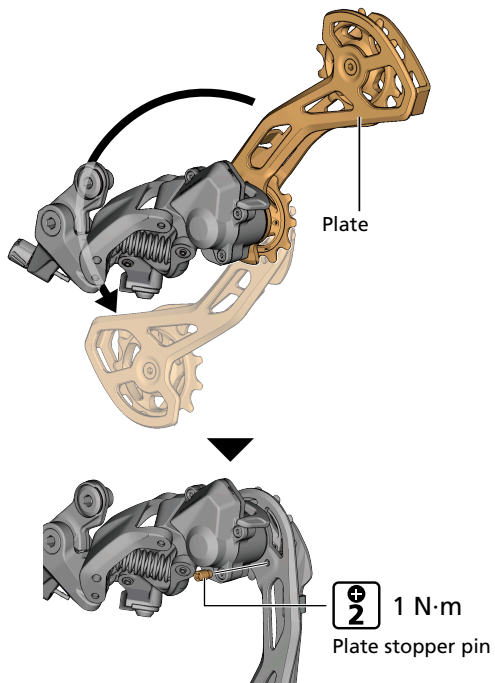

NOTICE

- Hold the plate and rear derailleur body firmly when working, as there will be spring force applied to the plate.

9. Check the friction, and adjust as necessary.

Refer to " Adjusting friction " for the friction adjustment method.

SHIMANO

SHIMANO NORTH AMERICA BICYCLE, INC.
One Holland, Irvine, California 92618, U.S.A. Phone: +1-949-951-5003

SHIMANO EUROPE B.V.
High Tech Campus 92, 5656 AG Eindhoven, The Netherlands Phone: +31-402-612222

SHIMANO INC.
3-77 Oimatsu-cho, Sakai-ku, Sakai City, Osaka 590-8577, Japan

Please note: specifications are subject to change for improvement without notice. (English)
© Mar. 2023 by SHIMANO INC. ITP