

Dealer's Manual

Front derailleur

MTB

FD-M670
FD-M671
FD-M675
FD-M676
FD-M785
FD-M785-E2
FD-M786

Trekking

FD-T670
FD-T671
FD-T780
FD-T781

ROAD

FD-3500
FD-3503
FD-A050
FD-A070

CONTENTS

IMPORTANT NOTICE	3
TO ENSURE SAFETY	4
LIST OF TOOLS TO BE USED	7
INSTALLATION	9
Installation of the front derailleur (for MTB/Trekking)	9
■ Direct mount type.....	9
Installation of the front derailleur (for ROAD)	11
ADJUSTMENT	13
SIS adjustment (for MTB/Trekking)	13
■ 2x10	13
■ 3x10	19
SIS adjustment (for ROAD).....	25
■ Double: FD-3500	25
■ Triple: FD-3503	28
■ FD-A070.....	31
MAINTENANCE	36

IMPORTANT NOTICE

- **This dealer's manual is intended primarily for use by professional bicycle mechanics.**

Users who are not professionally trained for bicycle assembly should not attempt to install the components themselves using the dealer's manuals.

If any part of the information on the manual is unclear to you, do not proceed with the installation. Instead, contact your place of purchase or a local bicycle dealer for their assistance.

- Make sure to read all instruction manuals included with the product.
- Do not disassemble or modify the product other than as stated in the information contained in this dealer's manual.
- All dealer's manuals and instruction manuals can be viewed on-line on our website (<http://si.shimano.com>).
- Please observe the appropriate rules and regulations of the country, state or region in which you conduct your business as a dealer.

For safety, be sure to read this dealer's manual thoroughly before use, and follow it for correct use.

The following instructions must be observed at all times in order to prevent personal injury and physical damage to equipment and surroundings.

The instructions are classified according to the degree of danger or damage which may occur if the product is used incorrectly.

DANGER

Failure to follow the instructions will result in death or serious injury.

WARNING

Failure to follow the instructions could result in death or serious injury.

CAUTION

Failure to follow the instructions could cause personal injury or physical damage to equipment and surroundings.

TO ENSURE SAFETY

WARNING

- Be sure to follow the instructions provided in the manuals when installing the product.

It is recommended to use genuine Shimano parts only. If parts such as bolts and nuts become loose or damaged, the bicycle may suddenly fall over, which may cause serious injury.

In addition, if adjustments are not carried out correctly, problems may occur, and the bicycle may suddenly fall over, which may cause serious injury.

-  Be sure to wear safety glasses or goggles to protect your eyes while performing maintenance tasks such as replacing parts.
- After reading the dealer's manual thoroughly, keep it in a safe place for later reference.

Be sure to also inform users of the following:

- Be careful not to let the hemming of your clothes get caught in the chain while riding. Otherwise you may fall off the bicycle.







NOTE

Be sure to also inform users of the following:

- If gear shifting operations do not feel smooth, wash the derailleur and lubricate all moving parts.





MTB/Trekking

- When the chain is in any of the positions shown in the illustration, the chain may come into contact with the front chainring or front derailleur and generate noise. If noise is a problem, shift the chain onto the next largest rear sprocket or the one after if the chain is in the position shown in Figure 1. Shift the chain onto the next smallest sprocket or the one after if it is in the position shown in Figure 2.

	Figure 1		Figure 2
	Double	Triple	
Front chainring			
Rear sprocket			

ROAD

- When the chain is in any of the positions shown in the illustration, the chain may come into contact with the front chainring or front derailleur and generate noise. If the noise is a problem, shift the chain onto the next largest sprocket or the one after.

	Double	Triple
Front chainring		
Rear sprocket		

For Installation to the Bicycle, and Maintenance:

- A triple front derailleur cannot be used with a double crankset because the shifting points do not match. Similarly, a double front derailleur cannot also be used with a triple crankset.

Double: FD-M675, M676, 3500, A070, M785, M786

Triple: FD-M670, M671, T670, T671, 3503, T780, T781

For detailed specifications, refer to specifications on our website for dealer's manuals.



- For frames with suspension, the chainstay angle will vary depending on whether the bicycle is being ridden or not being ridden. When the bicycle is not being ridden and the chain is positioned on the largest chainring and on the smallest sprocket, the chain guide outer plate of the front derailleur may touch the chain.
- Use an OT-SP cable and cable guide for smooth operation.
- If the amount of looseness in the links is so great that adjustment is not possible, you should replace the derailleur.
- A special grease is used for the gear shifting cable. Do not use premium grease or other types of grease, otherwise they may cause deterioration in gear shifting performance.
- Grease the inner cable and the inside of the outer casing before use to ensure that they slide properly.
- Operation of the levers related to gear shifting should be made only when the front chainwheel is turning.
- Products are not guaranteed against natural wear and deterioration from normal use and aging.
- For maximum performance we highly recommend Shimano lubricants and maintenance products.

The actual product may differ from the illustration because this manual is intended mainly to explain the procedures for using the product.

LIST OF TOOLS TO BE USED

LIST OF TOOLS TO BE USED

The following tools are needed for installation, adjustment, and maintenance purposes.

Tool		Tool		Tool	
	5mm Allen key		8mm spanner		Screwdriver[#2]

INSTALLATION

INSTALLATION

NOTE

When installing components to a carbon frame (handlebars), there is a risk of causing damage to the frame (handlebars) or inadequate fixing force, even at the recommended tightening torque. Verify the appropriate torque to apply with the bicycle or frame (handlebar) manufacturer.

Installation of the front derailleur (for MTB/Trekking)

For information on how to install types other than direct mount, refer to the SIS ADJUSTMENT FRONT DERAILLEUR FOR MTB/TREKKING section of General Operations.

■ Direct mount type

Install the front derailleur as shown in the illustration. At this time, adjust the position of the front derailleur while installing it so that there is a clearance of 1 - 3mm between the chain guide outer plate and the maximum outer diameter of the largest chainring.

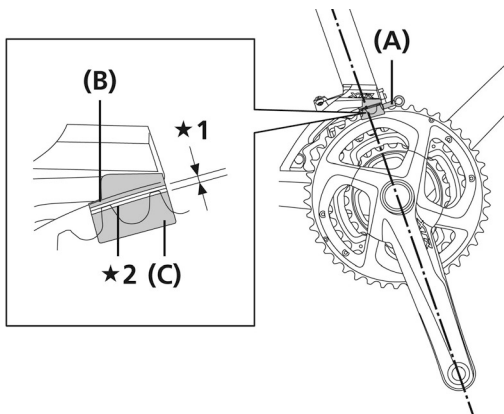

- ★1 Clearance: 1 - 3mm
- ★2 Maximum outer diameter

- (A) Pro-Set alignment block
- (B) Chain guide outer plate
- (C) Pro-Set gauge

1. Adjust the height of the front derailleur.
2. The flat section of the chain guide outer plate should be directly above and parallel to the largest chainring.

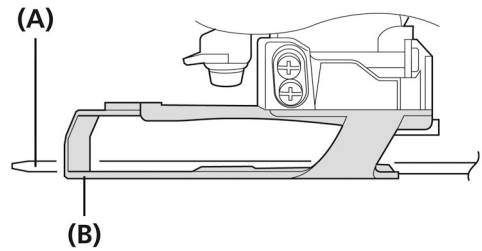

- (A) Chainwheel (largest chainring)
- (B) Chain guide

3. Secure using a 5mm Allen key.

* The mounting height varies depending on the position of the base of the frame.

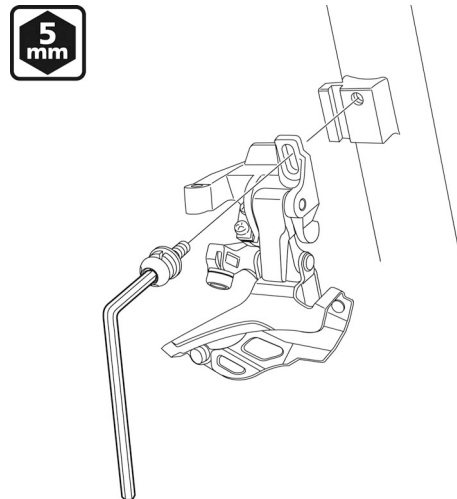

Tightening torque
5mm Allen key
5 - 7 N·m
{44 - 61 in. lbs.}

Double: 155.5mm (from center of bottom bracket)

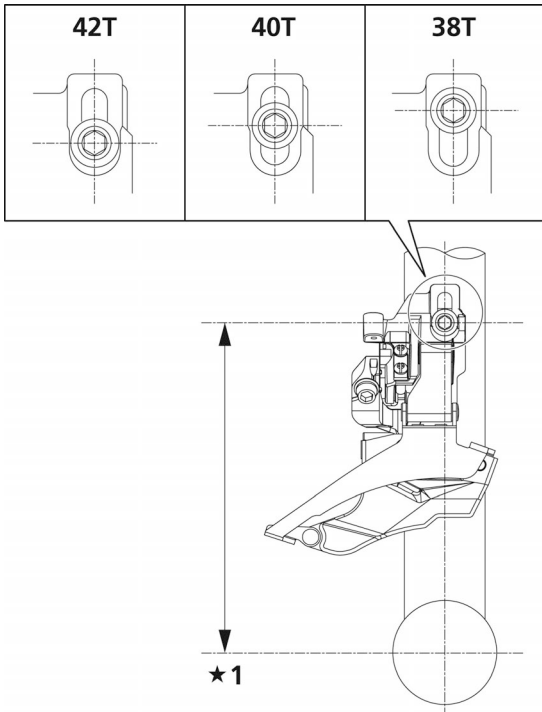

★1 Installation height

Double: 159.5mm (from center of bottom bracket)

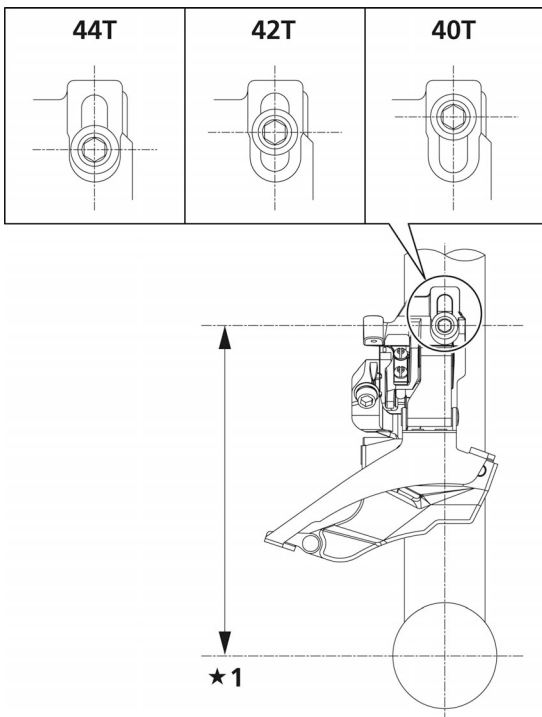

★1 Installation height

Triple: 155.5mm (from center of bottom bracket)

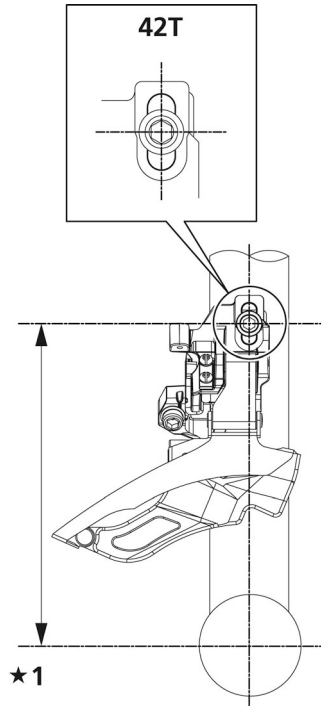

★1 Installation height

Triple: 159.5mm (from center of bottom bracket)

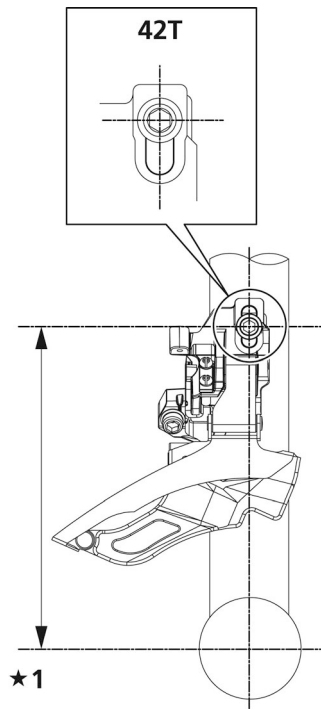

★1 Installation height

Models without a bottom bracket plate

* Example: When using an Allen key

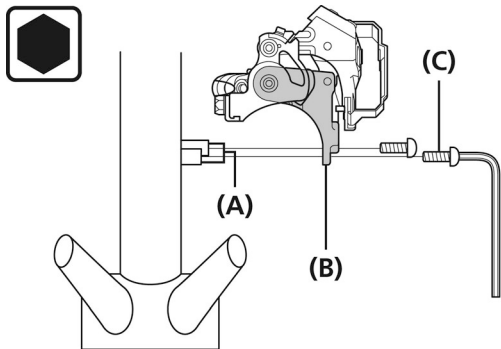

- (A) Bottom bracket mount
- (B) Bracket
- (C) Bottom bracket mount fixing bolt

Tightening torque
Allen key
5 - 7 N·m
{44 - 61 in. lbs.}

NOTE

Shimano does not provide the bottom bracket mount fixing bolts.

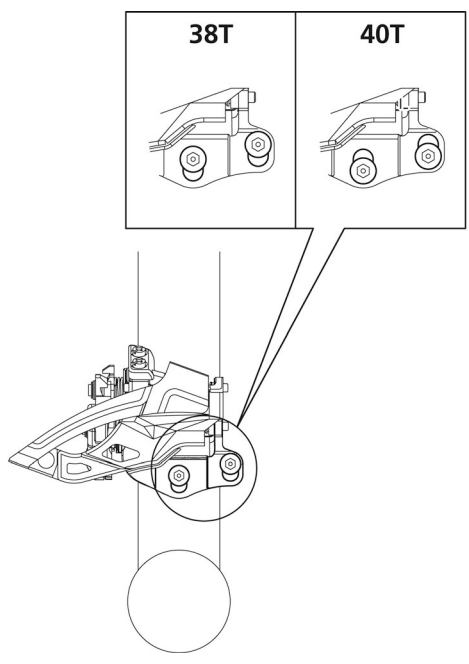

Installation of the front derailleur (for ROAD)

For information on installation, refer to the SIS ADJUSTMENT FRONT DERAILLEUR FOR ROAD section of General Operations.

ADJUSTMENT

ADJUSTMENT

SIS adjustment (for MTB/Trekking)

If the bicycle has rear suspension, first check the recommended default position according to the owner's manual. Next, use a fixing band or a similar object to set the rear suspension to the recommended stroke, and adjust the front derailleur.

Cutting the outer casing

- When cutting the outer casing, cut the end opposite to the end with the marking. After cutting it, make the end round so that the inside of the hole has a uniform diameter.



- Attach the same outer end cap to the cut end of the outer casing.

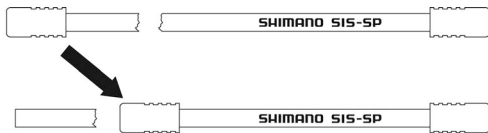

■ 2x10

Be sure to follow the sequence described below.

Low adjustment

- Set so that the clearance between the chain guide inner plate and the chain is 0 - 0.5mm.

Chain position

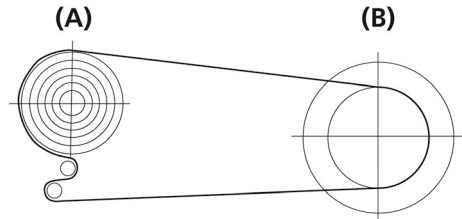

- (A) Largest sprocket
- (B) Smallest chainring

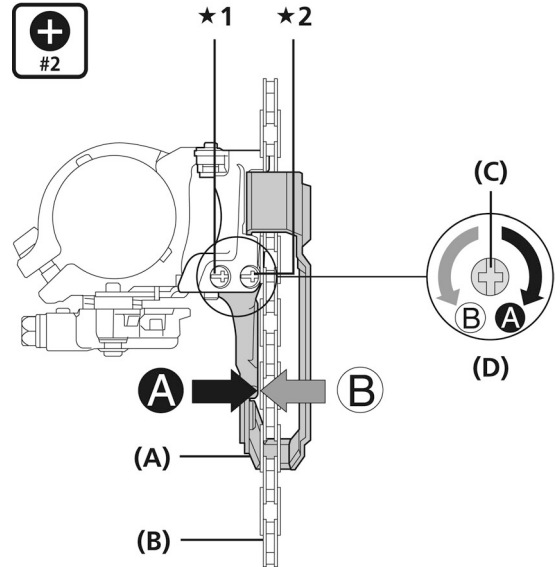

- ★1 Down swing type
- ★2 Top swing type

- (A) Chain guide inner plate
- (B) Chain
- (C) Screwdriver[#2]
- (D) Low adjustment bolt

- Switch the mode converter to triple mode (3x), and then check the lowest position. Operate lever B two times or more to set the lever to the lowest position.

XTR/DEORE XT

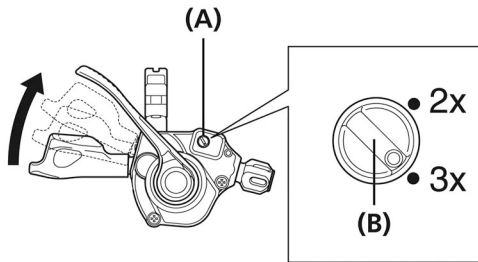

- (A) Mode converter
- (B) Mode select switch

NOTE

SL-M980/M780

Do not force the mode select switch to turn.
If you force it to turn, it will break.

SLX

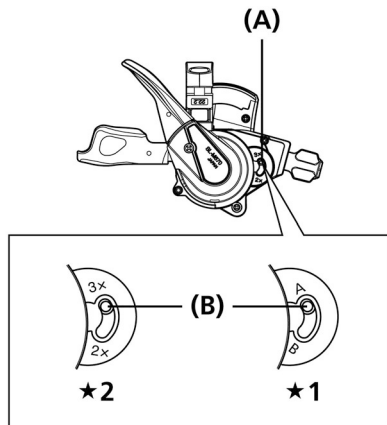

- ★1 New
- ★2 Old

- (A) Mode converter
- (B) Mode select switch

- Operate lever A once to set it to the middle position. Switch the mode converter to double mode (2x).

XTR/DEORE XT

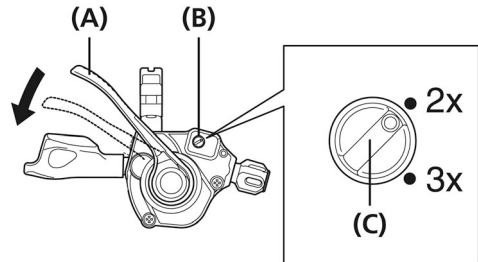

- (A) Lever A
- (B) Mode converter
- (C) Mode select switch

NOTE

SL-M980/M780

The mode converter cannot be switched while the lever is at the lowest position.

Be sure to operate lever A one or more times before switching.

If you force it to turn, it will break.

SLX

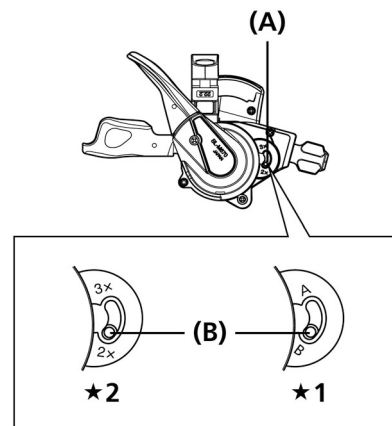

- ★1 New
- ★2 Old

- (A) Mode converter
- (B) Mode select switch

4. Secure the wire.
Use a spanner or an Allen key to tighten the wire mounting bolt.

Top swing type:

FD-M675-B/FD-M675-E2/FD-M785/FD-M785-E2

- Normal type

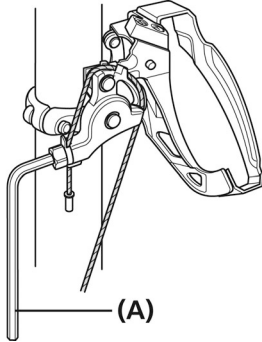

(A) 5mm Allen key/8mm spanner

Tightening torque
5mm Allen key/8mm spanner
6 - 7 N·m
{53 - 61 in. lbs.}

NOTE

Route the inner cable as shown in the illustration.

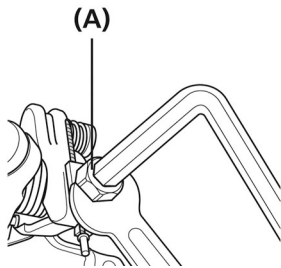

(A) Wire mounting bolt

- Top route type

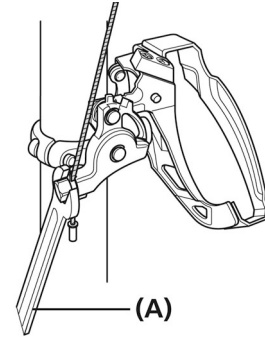

(A) 5mm Allen key/8mm spanner

Tightening torque
5mm Allen key/8mm spanner
6 - 7 N·m
{53 - 61 in. lbs.}

NOTE

Route the inner cable as shown in the illustration.

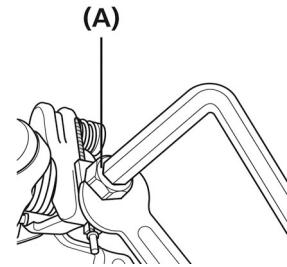

(A) Wire mounting bolt

Down swing type: FD-M676-B/FD-M676-D

- Normal type

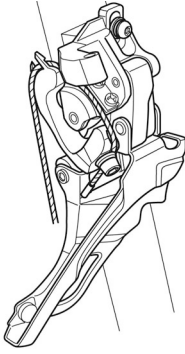

Tightening torque

5mm Allen key
6 - 7 N·m
 {53 - 61 in. lbs.}

NOTE

Route the inner cable as shown in the illustration.

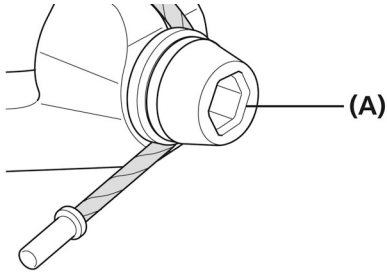

(A) Wire mounting bolt

- Top route type

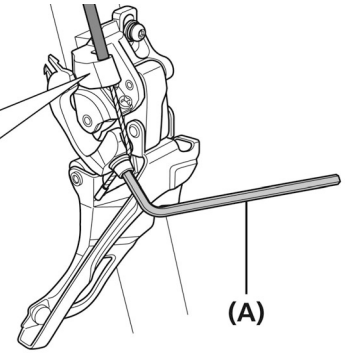
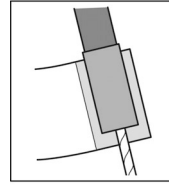

(A) 5mm Allen key

Tightening torque

5mm Allen key
6 - 7 N·m
 {53 - 61 in. lbs.}

NOTE

Route the inner cable as shown in the illustration.

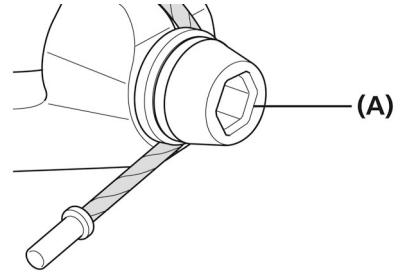

(A) Wire mounting bolt

5. After taking up the initial slack in the cable, re-secure to the front derailleur as shown in the illustration.

- Normal type

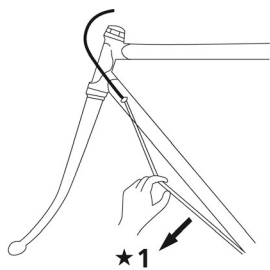

★1 Pull

- Top route type

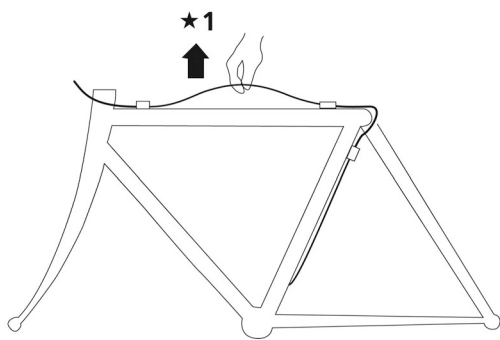

★1 Pull

Adjustment of cable tension

1. Set the chain to the largest rear sprocket, and shift to the largest chainring.

Chain position

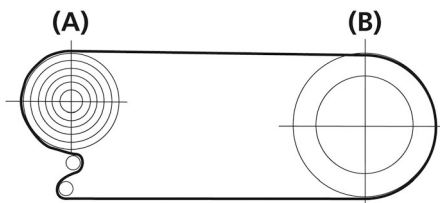

- (A) Largest sprocket
- (B) Largest chainring

2. Adjust using the cable adjustment barrel so that the clearance between the chain guide inner plate and the chain is 0 - 0.5mm.

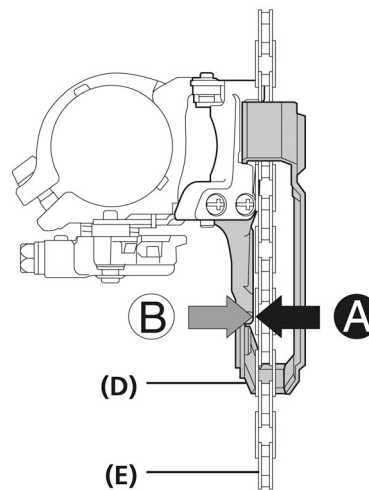
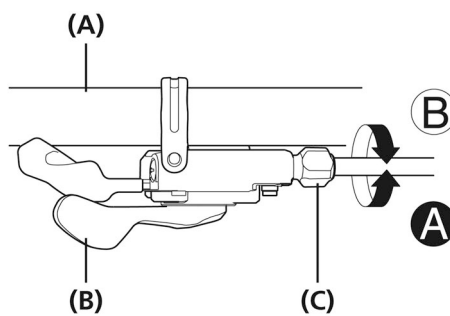

- (A) Handlebar
- (B) Shifting lever
- (C) Cable adjustment barrel
- (D) Chain guide inner plate
- (E) Chain

Top adjustment

- Adjust so that the clearance between the chain guide outer plate and the chain is 0 - 0.5mm.

Chain position

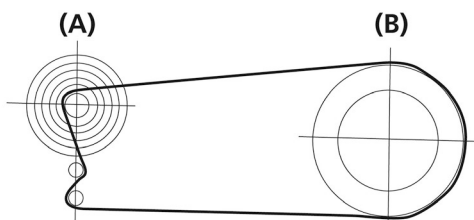

- (A) Smallest sprocket
(B) Largest chainring

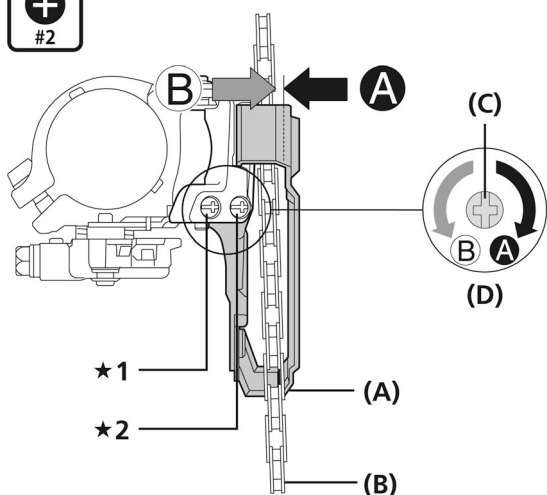

- ★1 Top swing type
★2 Down swing type

- (A) Chain guide outer plate
(B) Chain
(C) Screwdriver[#2]
(D) Top adjustment bolt

Troubleshooting chart

After completing low adjustment, cable tension adjustment, and top adjustment, check gear shifting by operating the shifting lever.

(This also applies if shifting becomes difficult during use.)

* Turn the bolt by 1/8th turn for each adjustment.

If the chain falls to the crank side

Turn the top adjustment bolt clockwise.

If shifting is difficult from the smallest chainring to the largest chainring

Turn the top adjustment bolt counterclockwise. If this does not improve the condition, readjust cable tension.

If shifting is difficult from the largest chainring to the smallest chainring

Turn the low adjustment bolt counterclockwise.

If there is interference between the chain and the front derailleur inner plate when the chain is shifted to the largest sprocket while it is on the largest chainring

Turn the top adjustment bolt clockwise. If this does not improve the condition, turn the cable adjustment barrel clockwise.

If there is interference between the chain and the front derailleur outer plate when the chain is on the largest chainring

Turn the top adjustment bolt counterclockwise. If this does not improve the condition, turn the cable adjustment barrel counterclockwise.

If the chain falls to the bottom bracket side

Turn the low adjustment bolt clockwise.

■ 3x10

Be sure to follow the sequence described below.

Low adjustment

1. Remove the Pro-Set alignment block.

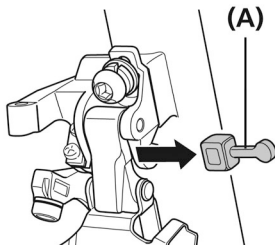

(A) Pro-Set alignment block

2. Set so that the clearance between the chain guide inner plate and the chain is 0 - 0.5mm.

Chain position

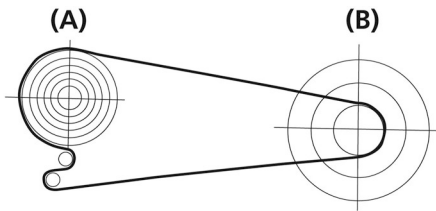

(A) Largest sprocket
(B) Smallest chainring

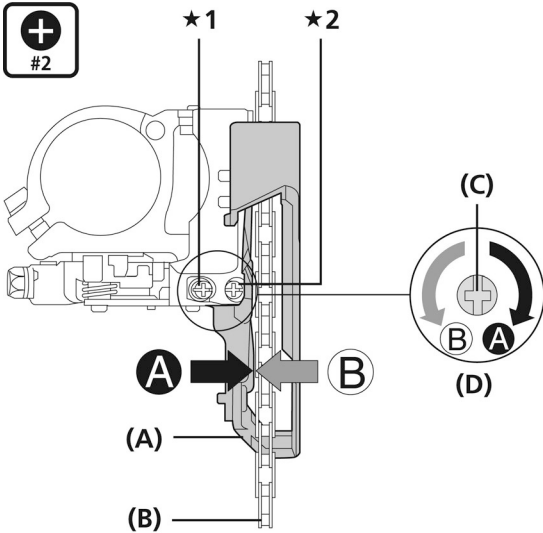

- ★1 Down swing type
- ★2 Top swing type

(A) Chain guide inner plate
(B) Chain
(C) Screwdriver[#2]
(D) Low adjustment bolt

3. Switch the mode converter to triple mode (3x), and then check the lowest position. Operate lever B two times or more to set the lever to the lowest position.

XTR/DEORE XT

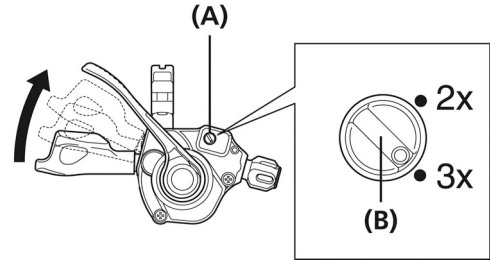

(A) Mode converter
(B) Mode select switch

NOTE

SL-M980/M780

Do not force the mode select switch to turn.
If you force it to turn, it will break.

TECH TIPS

SL-T780/SL-T670

Not equipped with a mode converter.
Set the lever to the lowest position.

SLX

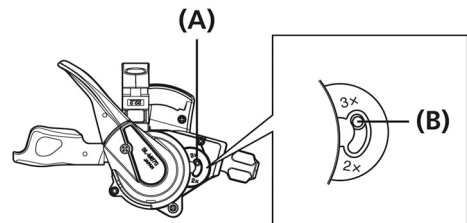

(A) Mode converter
(B) Mode select switch

4. Secure the wire.
Use a spanner or an Allen key to tighten the wire mounting bolt.

Top swing type:

FD-M670-B/FD-M670-E/FD-T670/FD-T780

- Normal type

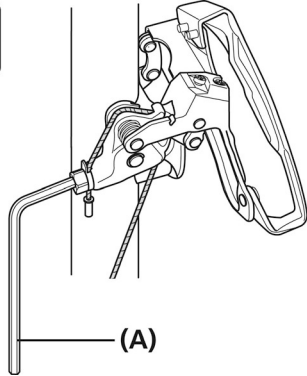

(A) 5mm Allen key/8mm spanner

Tightening torque
5mm Allen key/8mm spanner 6 - 7 N·m {53 - 61 in. lbs.}

NOTE

Route the inner cable as shown in the illustration.

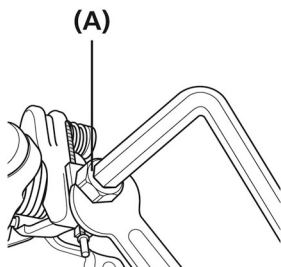

(A) Wire mounting bolt

- Top route type

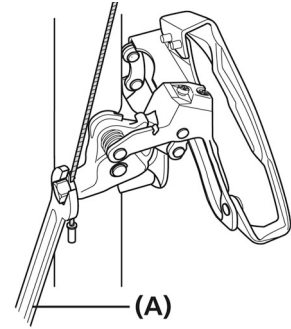

(A) 5mm Allen key/8mm spanner

Tightening torque
5mm Allen key/8mm spanner 6 - 7 N·m {53 - 61 in. lbs.}

NOTE

Route the inner cable as shown in the illustration.

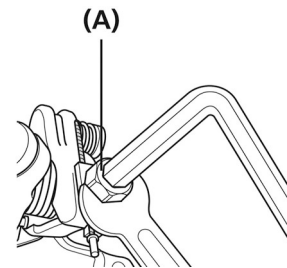

(A) Wire mounting bolt

Down swing type: FD-M671-B/FD-T671/FD-T781

- Normal type

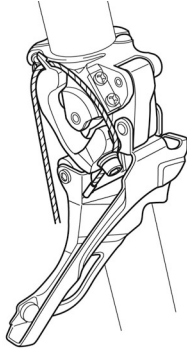

Tightening torque

5mm Allen key
6 - 7 N·m
 {53 - 61 in. lbs.}

NOTE

Route the inner cable as shown in the illustration.

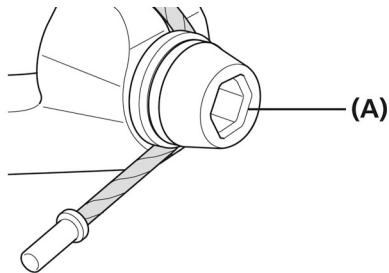

(A) Wire mounting bolt

- Top route type

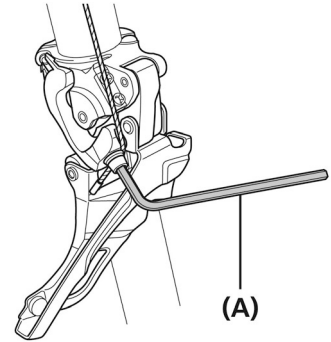

(A) 5mm Allen key

Tightening torque

5mm Allen key
6 - 7 N·m
 {53 - 61 in. lbs.}

NOTE

Route the inner cable as shown in the illustration.

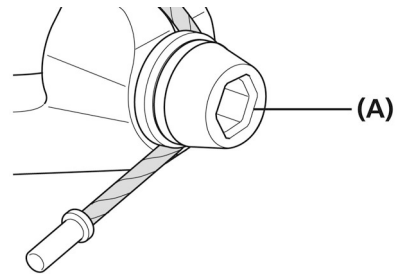

(A) Wire mounting bolt

Down swing type: FD-M671-D

- Normal type

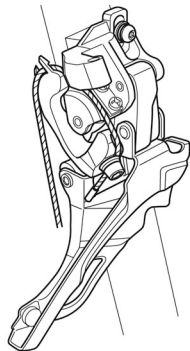

Tightening torque

5mm Allen key
6 - 7 N·m
 {53 - 61 in. lbs.}

NOTE

Route the inner cable as shown in the illustration.

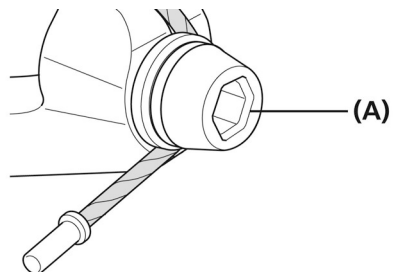

(A) Wire mounting bolt

- Top route type

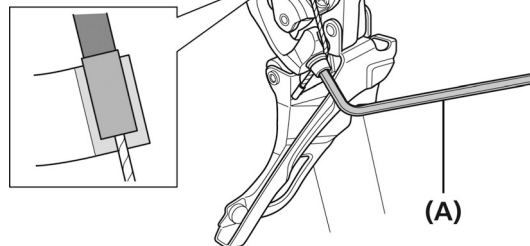

(A) 5mm Allen key

Tightening torque

5mm Allen key
6 - 7 N·m
 {53 - 61 in. lbs.}

NOTE

Route the inner cable as shown in the illustration.

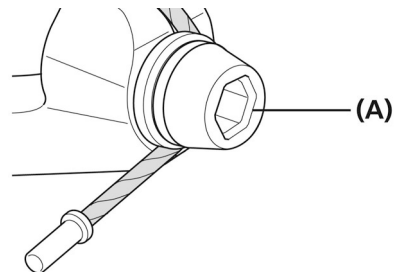

(A) Wire mounting bolt

5. After taking up the initial slack in the cable, re-secure to the front derailleur as shown in the illustration.

- Normal type

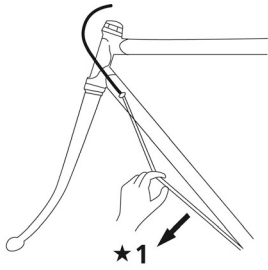

★1 Pull

- Top route type

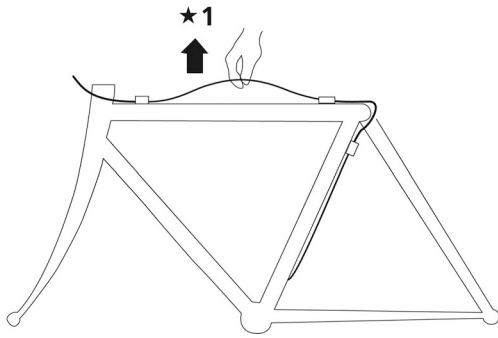

★1 Pull

Top adjustment

1. Adjust so that the clearance between the chain guide outer plate and the chain is 0 - 0.5mm.

Chain position

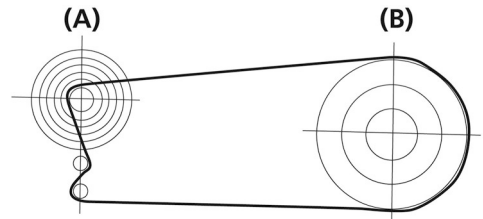

- (A) Smallest sprocket
- (B) Largest chainring

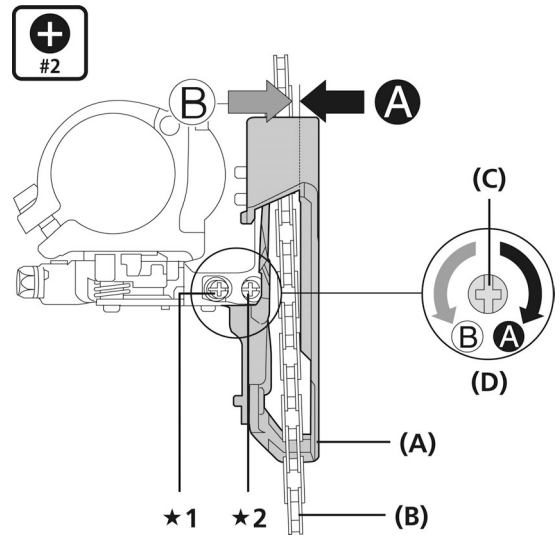

- ★1 Top swing type
- ★2 Down swing type

- (A) Chain guide outer plate
- (B) Chain
- (C) Screwdriver[#2]
- (D) Top adjustment bolt

Adjustment of the middle chainring

- When adjusting, set the chain to the largest sprocket, and at the front, set the chain to the middle chainring.

Chain position

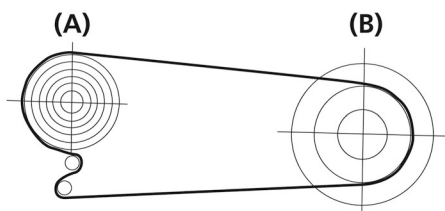

- (A) Largest sprocket
(B) Middle chainring

- Adjust using the cable adjustment barrel so that the clearance between the chain guide inner plate and the chain is 0 - 0.5mm.

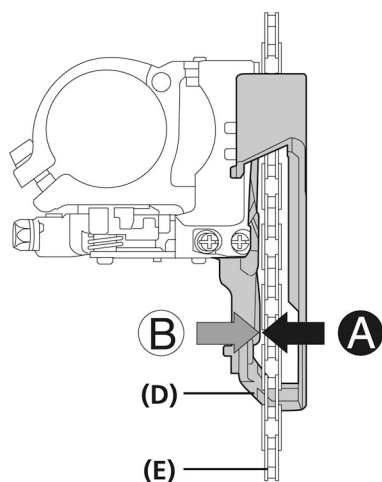
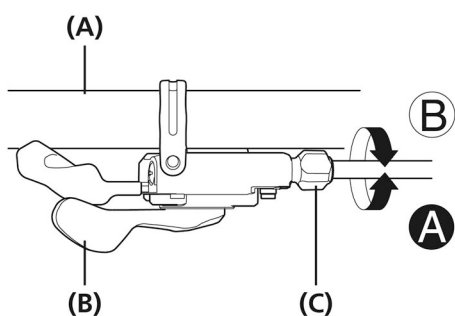

- (A) Handlebar
(B) Shifting lever
(C) Cable adjustment barrel
(D) Chain guide inner plate
(E) Chain

Troubleshooting chart

After completing low adjustment, top adjustment, and middle chainring adjustment, check gear shifting by operating the shifting lever.

(This also applies if shifting becomes difficult during use.)

* Turn the bolt by 1/8th turn for each adjustment.

If the chain falls to the crank side

Turn the top adjustment bolt clockwise.

If shifting is difficult from the middle chainring to the largest chainring

Turn the top adjustment bolt counterclockwise.

If shifting is difficult from the middle chainring to the smallest chainring

Turn the low adjustment bolt counterclockwise.

If there is interference between the chain and the front derailleur inner plate when the chain is on the largest chainring

Turn the top adjustment bolt clockwise.

If there is interference between the chain and the front derailleur outer plate when the chain is on the largest chainring

Turn the top adjustment bolt counterclockwise.

If the middle chainring is skipped when shifting from the largest chainring

Turn the cable adjustment barrel counterclockwise.

If there is interference between the chain and the front derailleur inner plate when the chain is shifted to the largest sprocket while it is on the middle chainring

Turn the cable adjustment barrel clockwise.

If the chain falls to the bottom bracket side

Turn the low adjustment bolt clockwise.

If the lever is stiff when shifting from the middle chainring to the largest chainring

Turn the top adjustment bolt counterclockwise.

SIS adjustment (for ROAD)

■ Double: FD-3500

Low adjustment

1. Adjust so that the clearance between the chain guide inner plate and the chain is 0 - 0.5mm.

Chain position

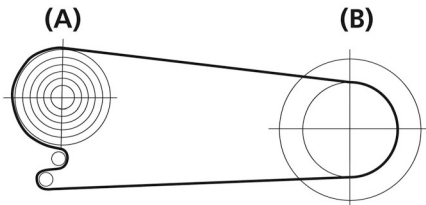

- (A) Largest sprocket
- (B) Smallest chainring

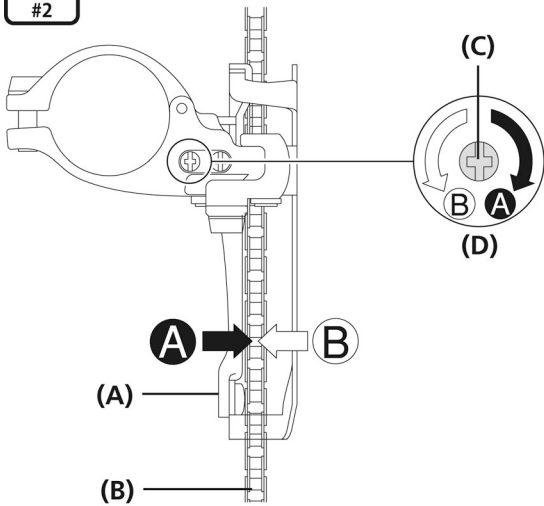

- (A) Chain guide inner plate
- (B) Chain
- (C) Screwdriver[#2]
- (D) Low adjustment bolt

Connecting and securing the inner cable

1. While pulling the inner cable, tighten the mounting bolt with a 5mm Allen key to secure the cable.

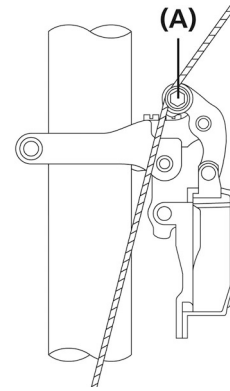

- (A) Wire mounting bolt

Tightening torque

5mm Allen key
6 - 7 N·m
{53 - 61 in. lbs.}

2. After taking up the initial slack in the cable, re-secure to the front derailleur as shown in the illustration.

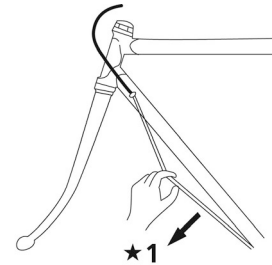

★1 Pull

Adjustment of cable tension

1. Set the chain on to the largest sprocket at the rear and, at the front, shift the chain to the smallest chainring and then back to the largest chainring.

Chain position

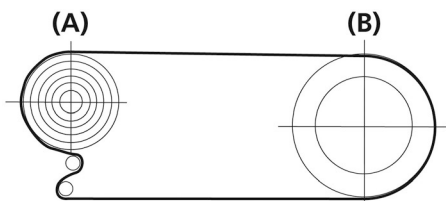

- (A) Largest sprocket
(B) Largest chainring

How to shift front chainrings

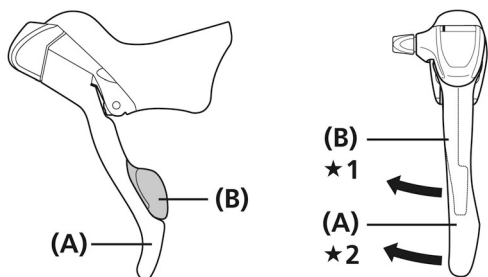

- ★1 From largest chainring to smallest chainring
- ★2 From smallest chainring to largest chainring

- (A) Lever [a]
(B) Lever [b]

2. Perform trimming (noise prevention operation).
 - Gently press the lever [b]. (A “click” sound will be heard.)

NOTE

Trimming operation (noise prevention operation)

There are two front derailleur positions when shifting to the largest chainring.

Make sure that the derailleur is in the innermore of the two positions.

- * Gear shift from the smallest chainring [L] to the largest chainring [T], then gently press lever [b] until there is a click.

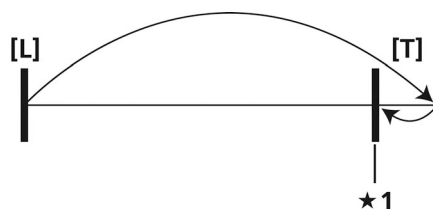

- ★1 Adjustment point

TECH TIPS

Move lever [b] lightly while turning the crank, and check that the front derailleur moves slightly toward the smallest chainring. At this time, if the front derailleur moves considerably and causes the chain engage the smallest chainring, turn the top adjustment bolt counterclockwise by 1/8 turn. Then, after returning the chain to its original position, adjust and check the trimming mechanism.

- After trimming, use the cable adjustment barrel to adjust the clearance between the chain and the chain guide inner plate to 0 - 0.5mm.

Chain position

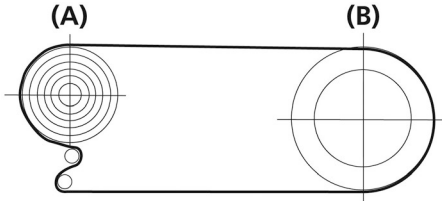

- (A) Largest sprocket
- (B) Largest chainring

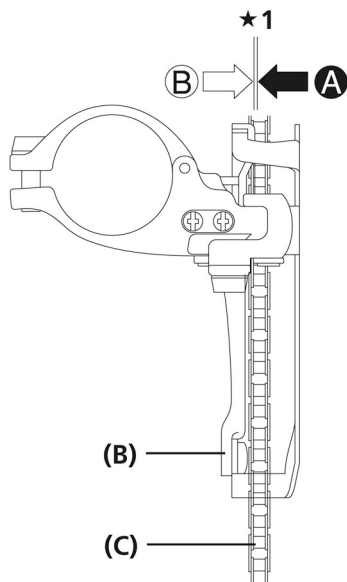
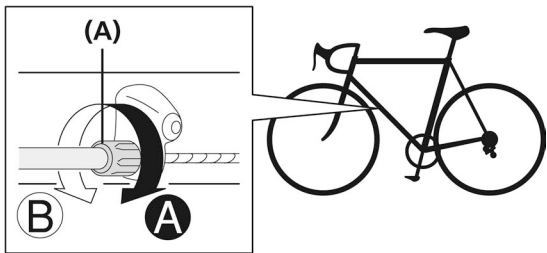

★1 Clearance: 0 - 0.5mm

- (A) Cable adjustment barrel
- (B) Chain guide inner plate
- (C) Chain

TECH TIPS

Adjustment is possible using the dual control lever (with cable adjuster).

For the adjustment method, refer to the dual control lever section.

Top adjustment

- Adjust so that the clearance between the chain guide outer plate and the chain is 0 - 0.5mm.

Chain position

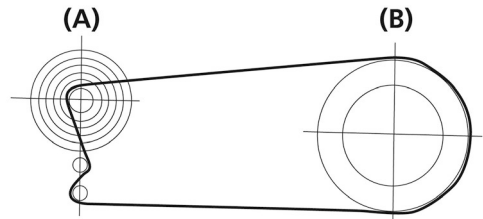

- (A) Smallest sprocket
- (B) Largest chainring

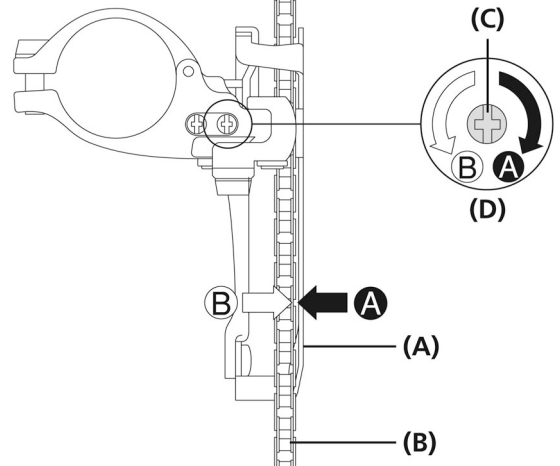

- (A) Chain guide outer plate
- (B) Chain
- (C) Screwdriver[#2]
- (D) Top adjustment bolt

Troubleshooting chart

After completing low adjustment, connecting and securing the inner cable, cable tension adjustment, and top adjustment, check gear shifting by operating the shifting lever. (This also applies if shifting becomes difficult during use.)

* Turn the bolt by 1/8th turn for each adjustment.

If the chain falls to the crank side
Turn the top adjustment bolt clockwise.

If shifting is difficult from the smallest chainring to the largest chainring
Turn the top adjustment bolt counterclockwise.
If this does not improve the condition, readjust cable tension.

If shifting is difficult from the largest chainring to the smallest chainring
Turn the low adjustment bolt counterclockwise.

If the chain falls to the bottom bracket side
Turn the low adjustment bolt clockwise.

If the gear shifting to the smallest chainring is stiff and difficult to carry out after trimming
Turn the cable adjustment barrel clockwise until gear shifting to the smallest chainring becomes smooth.
* Note that turning the cable adjustment barrel too much at one time may result in poorer gear shifting performance to the largest chainring.

Triple: FD-3503

Low adjustment

- Adjust so that the clearance between the chain guide inner plate and the chain is 0 - 0.5mm.

Chain position

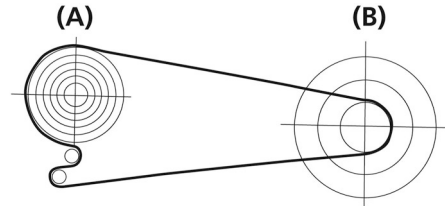

- (A) Largest sprocket
- (B) Smallest chainring

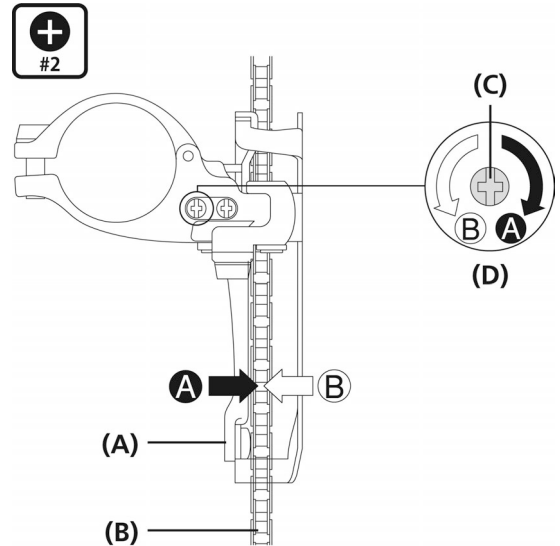

- (A) Chain guide inner plate
- (B) Chain
- (C) Screwdriver[#2]
- (D) Low adjustment bolt

Connecting and securing the inner cable

1. While pulling the inner cable, tighten the mounting bolt with a 5mm Allen key to secure the cable.

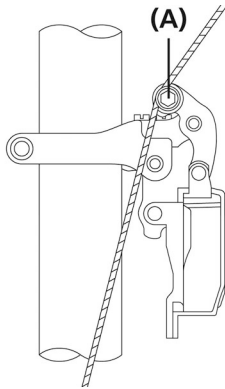

(A) Wire mounting bolt

Tightening torque

5mm Allen key

6 - 7 N·m

{53 - 61 in. lbs.}

2. After taking up the initial slack in the cable, re-secure to the front derailleur as shown in the illustration.

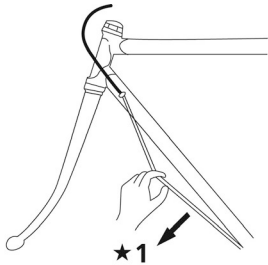

★1 Pull

Top adjustment

1. Adjust so that the clearance between the chain guide outer plate and the chain is 0 - 0.5mm.

Chain position

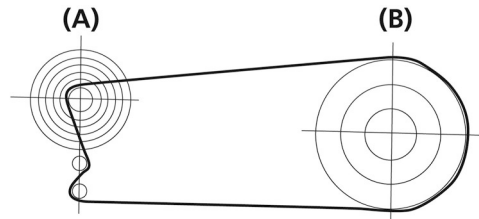

(A) Smallest sprocket

(B) Largest chainring

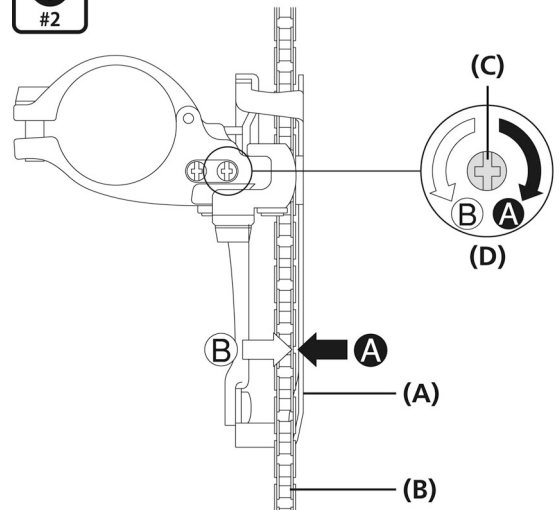

(A) Chain guide outer plate

(B) Chain

(C) Screwdriver[#2]

(D) Top adjustment bolt

Adjustment at the middle chainring

1. When adjusting, set the chain to the largest sprocket, and at the front, set the chain to the middle chainring.

NOTE

There are two ways to shift into the middle chainring: shifting from the largest chainring to the middle chainring, method [A], and shifting from the smallest chainring to the middle chainring, method [B]; use method [A]. This is because the position of the front derailleur differs.

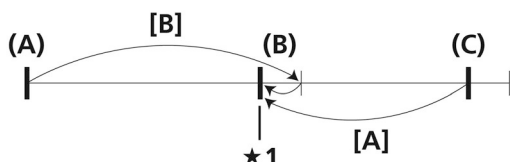

★1 Adjustment point

- (A) Smallest chainring
- (B) Middle chainring
- (C) Largest chainring

2. Adjust the cable adjustment barrel so that the clearance between the chain guide inner plate and the chain is 0 - 0.5mm.

Chain position

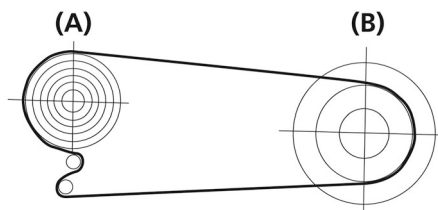

- (A) Largest sprocket
- (B) Middle chainring

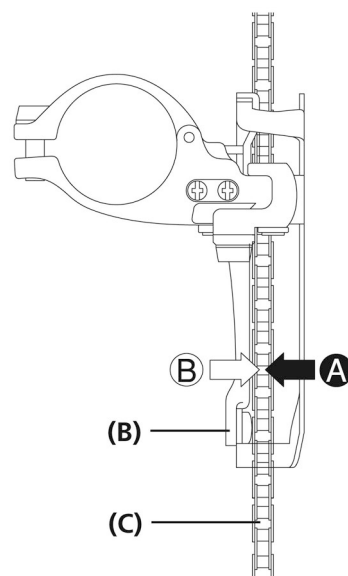
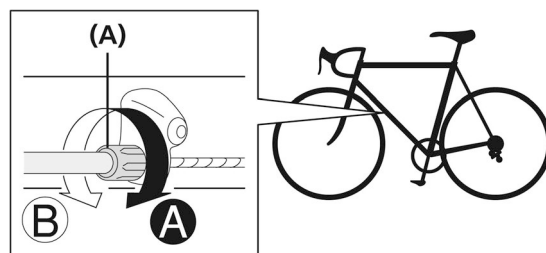

- (A) Cable adjustment barrel
- (B) Chain guide inner plate
- (C) Chain

TECH TIPS

Adjustment is possible using the dual control lever (with cable adjuster).

For the adjustment method, refer to the dual control lever section.

Troubleshooting chart

After completing low adjustment, connecting and securing the inner cable, top adjustment, and adjustment at the middle chainring, check gear shifting by operating the shifting lever.

(This also applies if shifting becomes difficult during use.)

* Turn the bolt by 1/8th turn for each adjustment.

If the chain falls to the crank side
Turn the top adjustment bolt clockwise.
If shifting is difficult from the middle chainring to the largest chainring
Turn the top adjustment bolt counterclockwise.
If shifting is difficult from the middle chainring to the smallest chainring
Turn the low adjustment bolt counterclockwise.
If there is interference between the chain and the front derailleur outer plate when the chain is on the largest chainring
Turn the top adjustment bolt counterclockwise.
If the middle chainring is skipped when shifting from the largest chainring
Turn the cable adjustment barrel counterclockwise.
If there is interference between the chain and the front derailleur inner plate when the chain is shifted to the largest sprocket while it is on the middle chainring
Turn the cable adjustment barrel clockwise.
If the chain falls to the bottom bracket side
Turn the low adjustment bolt clockwise.
If there is interference between the chain and the front derailleur inner plate when the chain is shifted to the largest sprocket while it is on the smallest chainring
Turn the low adjustment bolt counterclockwise.

■ **FD-A070**

Low adjustment

1. Adjust so that the clearance between the chain guide inner plate and the chain is 0 - 0.5mm.

Chain position

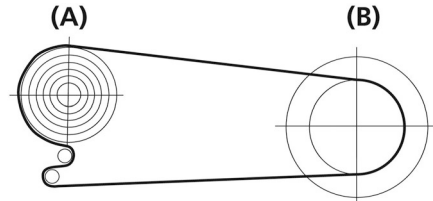

- (A) Largest sprocket
- (B) Smallest chainring

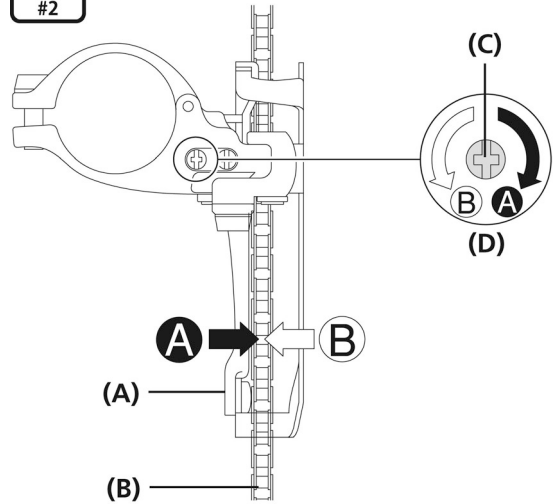

- (A) Chain guide inner plate
- (B) Chain
- (C) Screwdriver[#2]
- (D) Low adjustment bolt

Connecting and securing the inner cable

1. While pulling the inner cable, tighten the mounting bolt with a 5mm Allen key to secure the cable.

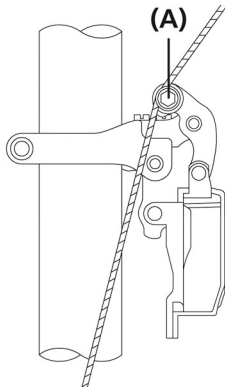

(A) Wire mounting bolt

Tightening torque
5mm Allen key
5 - 7 N·m
{44 - 61 in. lbs.}

2. After taking up the initial slack in the cable, re-secure to the front derailleur as shown in the illustration.

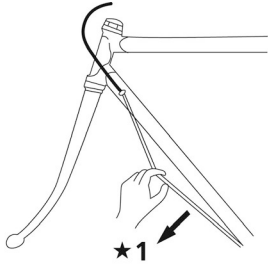

★1 Pull

Adjustment of cable tension

1. Set the chain to the largest rear sprocket, and shift to the largest chainring.

Chain position

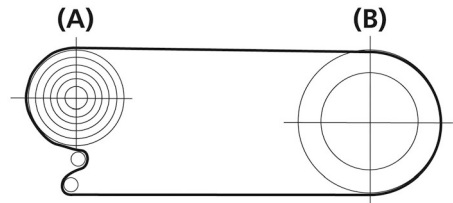

(A) Largest sprocket
(B) Largest chainring

How to shift front chainrings (ST-A070)

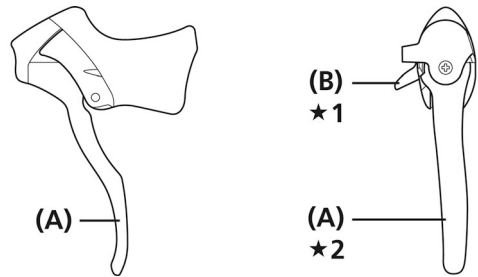

- ★1 From largest chainring to smallest chainring
- ★2 From smallest chainring to largest chainring

(A) Lever [a]
(B) Lever [b]

2. Perform trimming (noise prevention operation).
 - Gently press the lever [b]. (A "click" sound will be heard.)

NOTE

Trimming operation (noise prevention operation)

There are two front derailleur positions when shifting to the largest chainring.

Make sure that the derailleur is in the innermore of the two positions.

- * Gear shift from the smallest chainring [L] to the largest chainring [T], then gently press lever [b] until there is a click.

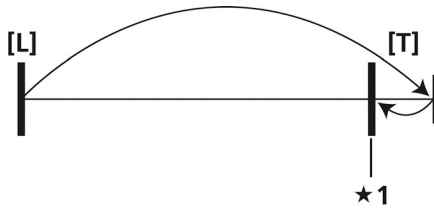

★1 Adjustment point

TECH TIPS

Move lever [b] lightly while turning the crank, and check that the front derailleur moves slightly toward the smallest chainring. At this time, if the front derailleur moves considerably and causes the chain engage the smallest chainring, turn the top adjustment bolt counterclockwise by 1/8 turn. Then, after returning the chain to its original position, adjust and check the trimming mechanism.

3. After trimming, use the cable adjustment barrel to adjust the clearance between the chain and the chain guide inner plate to 0 - 0.5mm.

Chain position

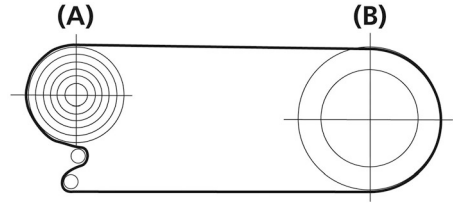

- (A) Largest sprocket
- (B) Largest chainring

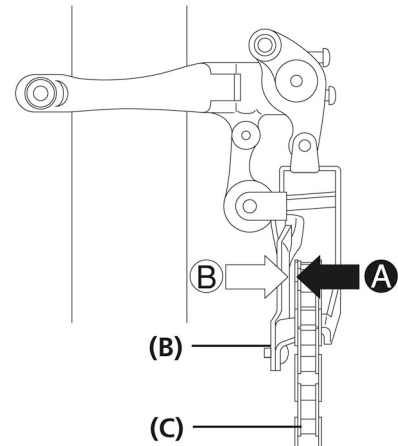
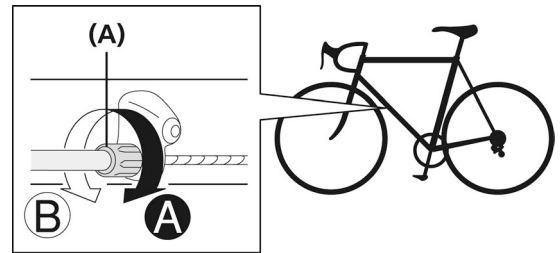

- (A) Cable adjustment barrel
- (B) Chain guide inner plate
- (C) Chain

Top adjustment

1. Adjust so that the clearance between the chain guide outer plate and the chain is 0 - 0.5mm.

Chain position

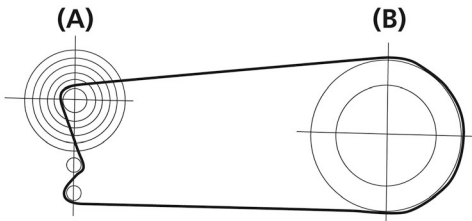

- (A) Smallest sprocket
- (B) Largest chainring

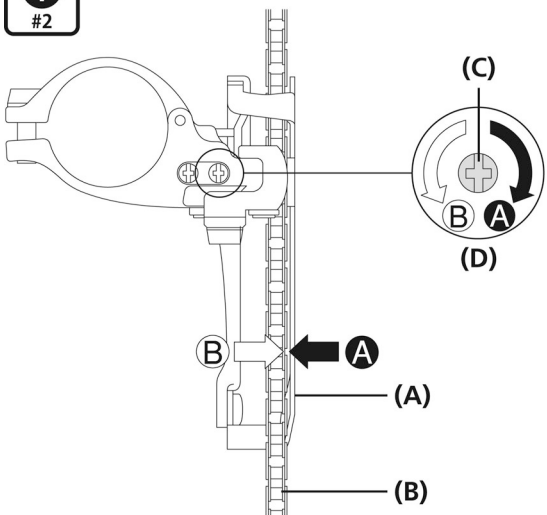

- (A) Chain guide outer plate
- (B) Chain
- (C) Screwdriver[#2]
- (D) Top adjustment bolt

Troubleshooting chart

After completing low adjustment, connecting and securing the inner cable, cable tension adjustment, and top adjustment, check gear shifting by operating the shifting lever. (This also applies if shifting becomes difficult during use.)

* Turn the bolt by 1/8th turn for each adjustment.

<p>If the chain falls to the crank side</p> <p>Turn the top adjustment bolt clockwise.</p>
<p>If shifting is difficult from the smallest chainring to the largest chainring</p> <p>Turn the top adjustment bolt counterclockwise. If this does not improve the condition, readjust cable tension.</p>
<p>If shifting is difficult from the largest chainring to the smallest chainring</p> <p>Turn the low adjustment bolt counterclockwise.</p>
<p>If the chain falls to the bottom bracket side</p> <p>Turn the low adjustment bolt clockwise.</p>
<p>If the gear shifting to the smallest chainring is stiff and difficult to carry out after trimming</p> <p>Turn the cable adjustment barrel clockwise until gear shifting to the smallest chainring becomes smooth. * Note that turning the cable adjustment barrel too much at one time may result in poorer gear shifting performance to the largest chainring.</p>

MAINTENANCE

MAINTENANCE

Lubricate moving parts (the links) shown in the illustrations.

TECH TIPS

If gear shifting operations do not feel smooth, wash the derailleur and lubricate all moving parts.

Type F

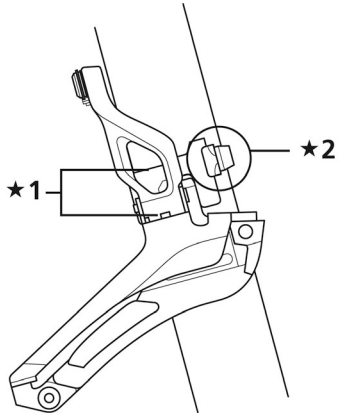

- ★1 Link
- ★2 Mounting section

Type B

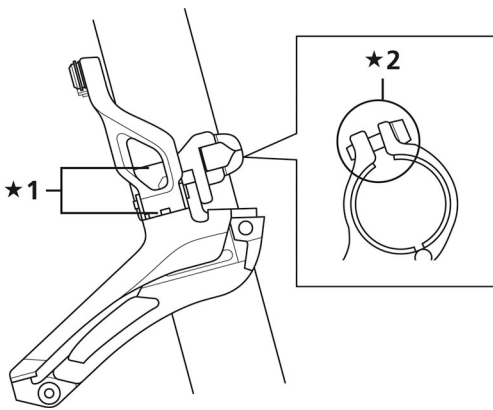

- ★1 Link
- ★2 Mounting section

Type E

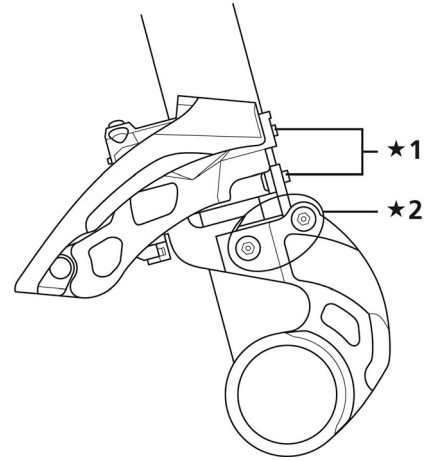

- ★1 Link
- ★2 Mounting section

Type D

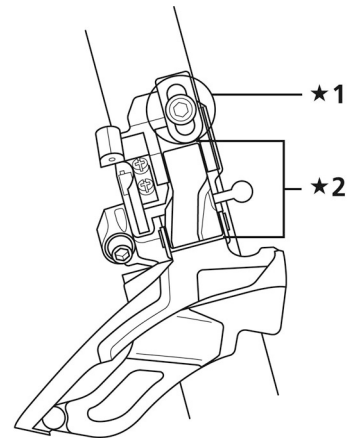

- ★1 Mounting section
- ★2 Link

SHIMANO

SHIMANO AMERICAN CORPORATION

One Holland, Irvine, California 92618, U.S.A. Phone: +1-949-951-5003

SHIMANO EUROPE B.V.

Industrieweg 24, 8071 CT Nunspeet, The Netherlands Phone: +31-341-272222

SHIMANO INC.

3-77 Oimatsu-cho, Sakai-ku, Sakai-shi, Osaka 590-8577, Japan

Please note: specifications are subject to change for improvement without notice. (English)
© March 2016 by Shimano Inc. HTR