

Dealer's Manual

**FC-M820 / FC-M825
SM-BB71 / SM-CR82**

IMPORTANT NOTICE

- **This dealer's manual is intended primarily for use by professional bicycle mechanics.**

Users who are not professionally trained for bicycle assembly should not attempt to install the components themselves using the dealer's manuals.

If any part of the information on the manual is unclear to you, do not proceed with the installation. Instead, contact your place of purchase or a local bicycle dealer for their assistance.

- Make sure to read all instruction manuals included with the product.
- Do not disassemble or modify the product other than as stated in the information contained in this dealer's manual.
- All dealer's manuals and instruction manuals can be viewed on-line on our website (<http://si.shimano.com>).
- Please observe the appropriate rules and regulations of the country, state or region in which you conduct your business as a dealer.

For safety, be sure to read this dealer's manual thoroughly before use, and follow it for correct use.

The following instructions must be observed at all times in order to prevent personal injury and physical damage to equipment and surroundings.

The instructions are classified according to the degree of danger or damage which may occur if the product is used incorrectly.

 **DANGER**

Failure to follow the instructions will result in death or serious injury.

 **WARNING**

Failure to follow the instructions could result in death or serious injury.

 **CAUTION**

Failure to follow the instructions could cause personal injury or physical damage to equipment and surroundings.

TO ENSURE SAFETY

WARNING

- **When installing components, be sure to follow the instructions that are given in the instruction manuals.**

It is recommended that you use only genuine Shimano parts. If parts such as bolts and nuts become loose or damaged, the bicycle may suddenly fall over, which may cause serious injury.

In addition, if adjustments are not carried out correctly, problems may occur, and the bicycle may suddenly fall over, which may cause serious injury.

-  Be sure to wear safety glasses or goggles to protect your eyes while performing maintenance tasks such as replacing parts.
- After reading the dealer's manual thoroughly, keep it in a safe place for later reference.

Be sure to also inform users of the following:

- Downhill bicycle riding and freeriding are inherently dangerous activities. There is a risk of being involved in an accident that can result in a serious injury or even death. It is strongly recommended that riders wear protective head and body gear and perform thorough safety checks of their bicycles before riding. Please remember that you are riding at your own risk and that you have to consider your experience and your skills very carefully.
- Check that there are no cracks in the crank arms before riding the bicycle. If there are any cracks, the crank arm may break and you may fall off the bicycle.
- The crankset is designed for downhill bicycle riding and off-road bicycle riding. However, depending on the riding conditions, a crank or a bottom bracket axle can develop a crack, which may result in the failure of the crank. This can lead to an accident that could result in a serious injury or even death.
Check periodically whether there are no cracks on your crankset or crank attachment axis.
- Be careful not to let the cuffs of your clothes get caught in the chain while riding, otherwise you may fall off the bicycle.

For Installation to the Bicycle, and Maintenance:

- If the inner cover is not installed correctly, the axle may rust and become damaged, and the bicycle may fall over and serious injury may occur as a result.
- The two left crank arm mounting bolts should be tightened alternately in stages rather than each bolt being fully tightened all at once. Use a torque wrench to check that the final tightening torques are within the range of 12 - 14 N·m {106 - 122 in. lbs.}. Furthermore, after riding approximately 100 km (60 miles), use a torque wrench to re-check the tightening torques. It is also important to periodically check the tightening torques. If the tightening torques are too weak or if the mounting bolts are not tightened alternately in stages, the left crank arm may come off and the bicycle may fall over, and serious injury may occur as a result.

CAUTION

Be sure to also inform users of the following:

- There is the danger of injury from the tips of the teeth on the chainrings.

NOTE

Be sure to also inform users of the following:

- Be sure to keep turning the crank during the lever operation.
- Before riding the bicycle, check that there is no play or looseness in the connection. Also, be sure to retighten the crank arms and pedals at periodic intervals.
- Use a neutral detergent to clean the crank arm and the bottom bracket. Using alkaline or acidic detergents may cause discoloration.
- If pedaling performance does not feel normal, check this once more.
- Do not wash the bottom bracket with high-pressure jets of water. Water may enter the bearing section and cause noise or adhesion.
- You should periodically wash the chainrings in a neutral detergent. In addition, cleaning the chain with neutral detergent and lubricating it can be an effective way of extending the useful life of the chainrings and the chain.
- The cuffs of your clothing may get dirty from the chain while riding.
- This product is not warranted against damage resulting from use such as jumping while riding or if the bicycle falls over, except if such malfunctions result from non conforming materials or manufacturing methods.
- Products are not guaranteed against natural wear and deterioration from normal use and aging.
- For maximum performance we highly recommend Shimano lubricants and maintenance products.

For Installation to the Bicycle, and Maintenance:

- When installing the left and right adapters, apply grease to them and be sure to install the inner cover. Otherwise the waterproofing performance will drop.
- When installing the pedals, apply a small amount of grease to the threads to prevent the pedals from sticking. Use a torque wrench to securely tighten the pedals. Tightening torque: 35 - 55 N·m {305 - 479 in. lbs.}. The right-hand crank arm has a right-hand thread, and the left-hand crank arm has a left-hand thread.
- If the chain keeps coming off the chainrings during use, replace the chainrings and the chain.
- To ensure the best performance, be sure to use only the specified type of chain.
- If a squeaking noise is heard coming from the bottom bracket axle and the left crank arm connector, apply grease to the connector and then tighten it to the specified torque.
- If you feel any looseness in the bearings, the bottom bracket should be replaced.

The actual product may differ from the illustration because this manual is intended chiefly to explain the procedures for using the product.

INSTALLATION

■ Installation of the chainring

1. Install the chainring so that the side with the markings is on the outside, and so that the Δ marking is pointing toward the crank arm.
2. Set fixing nuts on the crank arm.
 - Set the fixing nut to the bottom left by carrying out steps ① to ② as shown in the illustration.
3. Fix the chainring with fixing bolts.

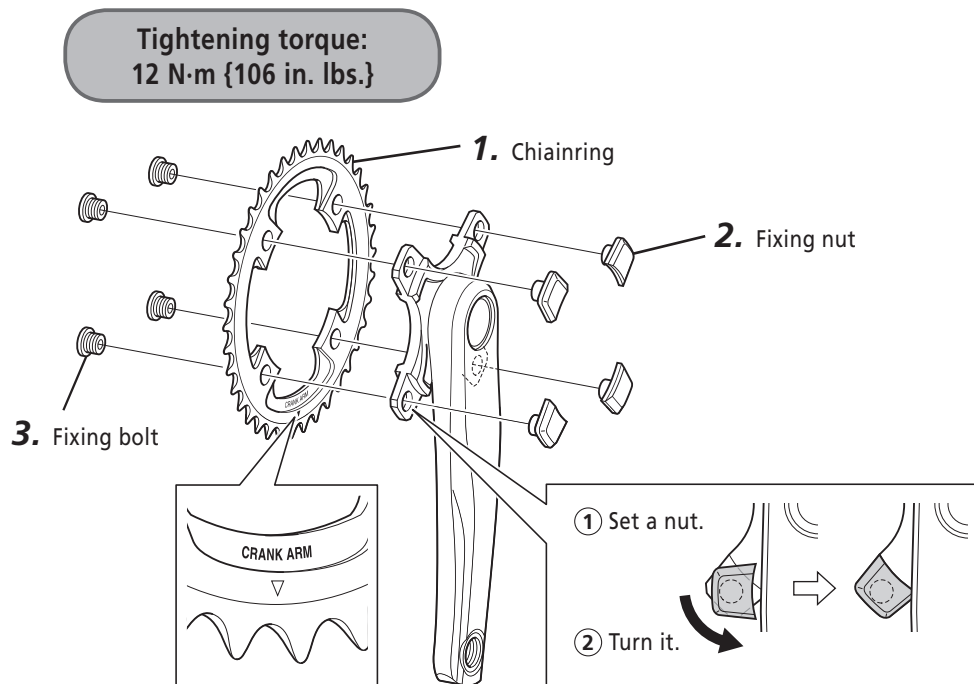

■ Installation of the crankset

* Refer to the crank section of General Operations, for how to install the crank.

■ Spacer installation method

1. Measure the bottom bracket shell width to check the size.

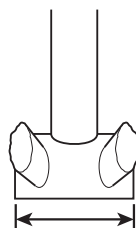

Bottom bracket shell width

2. Next, install the adapter while referring to the illustrations below.

- **FC-M820:** For bottom bracket shell width of 68 mm
- **FC-M825:** For bottom bracket shell width of 83 mm

- **FC-M820:** For bottom bracket shell width of 73 mm

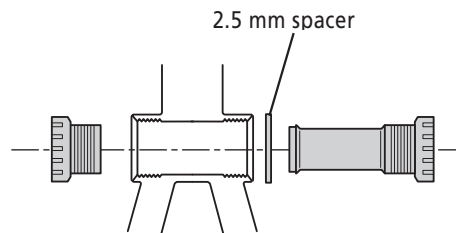
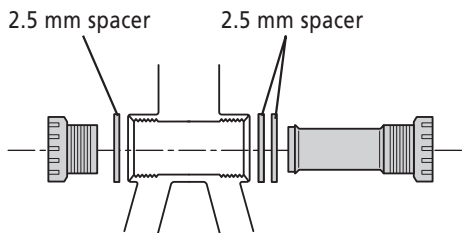

■ Installation of the press-fit bottom bracket adapter

Note:

If the frame has openings inside the bottom bracket shell, it should be installed with the inner cover sleeve to prevent possible contamination.

Spacer installation method

1. Measure the bottom bracket shell width to check the size.

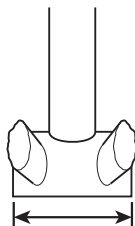

Bottom bracket shell width

2. Next, install the adapter while referring to the illustrations below.

- **FC-M820:** For bottom bracket shell width of 92 mm
- **FC-M825:** For bottom bracket shell width of 107 mm

- **FC-M820:** For bottom bracket shell width of 89.5 mm
- **FC-M825:** For bottom bracket shell width of 104.5 mm

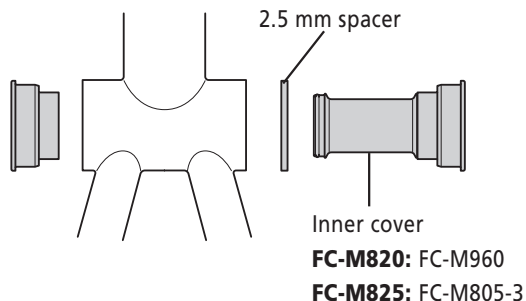
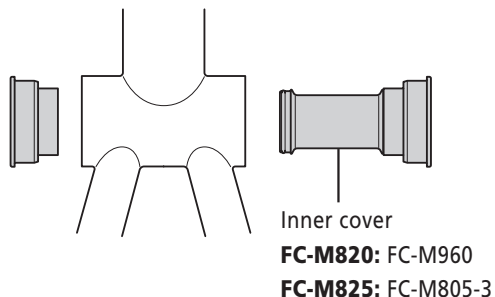

* Refer to the press-fit BB section of General Operations, for how to use the press-fitting tools (TL-BB12/13).

- P.6 If the frame has openings inside the bottom bracket shell, the press-fit bottom bracket adapter is available. In this case, be sure to install the inner cover.
→ If the frame has openings inside the bottom bracket shell, it should be installed with the inner cover sleeve to prevent possible contamination.

SHIMANO

SHIMANO AMERICAN CORPORATION

One Holland, Irvine, California 92618, U.S.A. Phone: +1-949-951-5003

SHIMANO EUROPE B.V.

Industrieweg 24, 8071 CT Nunspeet, The Netherlands Phone: +31-341-272222

SHIMANO INC.

3-77 Oimatsu-cho, Sakai-ku, Sakai-shi, Osaka 590-8577, Japan

Please note: specifications are subject to change for improvement without notice. (English)

© Oct. 2012 by Shimano Inc. HTR