

# Dealer's Manual

ROAD	GRAVEL	MTB
E-BIKE	LIFESTYLE	GENERAL

## EP8 / EP6 / EP5

### EP8

DU-EP801  
DU-EP801-CRG

### EP6

DU-EP600  
DU-EP600-CRG

### EP5

DU-EP500

### E8000

SM-CRE80  
SM-CRE80-B

### SHIMANO (E-BIKE)

CR-EM800  
CR-ET600  
DC-EP801-A  
DC-EP801-B  
DC-EP801-G  
EW-SS300  
EW-SS301  
EW-SS302  
FC-EM900  
FC-EM600  
FC-EN500  
FC-M8150  
SM-CRE61  
SM-CRE70-12  
SM-CRE80-12-B  
SM-CRE80-12-SB

---

## Contents

<b>IMPORTANT NOTICE</b> .....	<b>4</b>
<b>TO ENSURE SAFETY</b> .....	<b>5</b>
<b>Anti-tampering function</b> .....	<b>8</b>
<b>Booklet structure</b> .....	<b>9</b>
<b>List of tools to be used</b> .....	<b>11</b>
<b>Installing electrical parts</b> .....	<b>12</b>
SHIMANO E-BIKE SYSTEMS battery management systems and compatibility.....	12
Names of parts .....	13
• External type .....	13
• Integrated type .....	14
• Rear carrier type .....	14
Overall wiring diagram.....	16
Specifications.....	17
Electric wires.....	18
• Supported products .....	18
• Conversion adapter .....	19
• Connecting/disconnecting the electric wires .....	19
Installing cockpit peripheral components .....	23
Installing the battery mount and parts .....	24
Installing the speed sensor .....	25
• Generic type .....	25
• Type designed exclusively for use with a rotor with magnet .....	26
• Type designed exclusively for use with a lock ring with magnet .....	27
<b>Installing the drive unit and peripheral parts</b> .....	<b>28</b>
Introduction .....	28
Installing the drive unit .....	29
Connecting the power cord .....	30
• Connection method .....	30
• Removal method .....	30
Connecting cockpit peripheral parts and electronic gear shifting	

---

components .....	32
Connecting the speed sensor .....	33
Connecting the light cables.....	34
Connecting the CAN cable .....	36
• Connecting the CAN cable .....	36
• Removing the CAN cable .....	38
Installing the drive unit cover .....	40
• Affixing the thermal hazard label .....	40
Installing the chainring unit and crank arms .....	42
Installing the arm covers .....	46
Measuring and adjusting the chain tension.....	47
• Manual adjustment .....	47
• Measuring and adjusting with TL-DUE60 .....	47
<b>Connection and communication with devices.....</b>	<b>49</b>
<b>Maintenance.....</b>	<b>50</b>
Replacing the chainring unit.....	50
Replacing the chain guard .....	52
Replacing the arm cover.....	53

# IMPORTANT NOTICE

- **This dealer's manual is intended primarily for use by professional bicycle mechanics.**

Users who are not professionally trained for bicycle assembly should not attempt to install the components themselves using the dealer's manuals.

If any part of the information on the manual is unclear to you, do not proceed with the installation. Instead, contact your place of purchase or a distributor for assistance.



- Make sure to read all manuals included with each product.
- Do not disassemble or modify the product other than as stated in the information contained in this dealer's manual.
- All manuals and technical documents are accessible online at <https://si.shimano.com>.
- For consumers who do not have easy access to the internet, please contact a SHIMANO distributor or any of the SHIMANO offices to obtain a hardcopy of the user's manual.
- Please observe the appropriate rules and regulations of the country, state or region in which you conduct your business as a dealer.
- The Bluetooth® word mark and logos are registered trademarks owned by the Bluetooth SIG, Inc. and any use of such marks by SHIMANO INC. is under license.

Other trademarks and trade names are those of their respective owners.

**For safety, be sure to read this dealer's manual thoroughly before use, and follow it for correct use.**

The following instructions must be observed at all times in order to prevent personal injury and physical damage to equipment and surroundings.

The instructions are classified according to the degree of danger or damage which may occur if the product is used incorrectly.

 <b>DANGER</b>	Failure to follow the instructions will result in death or serious injury.
 <b>WARNING</b>	Failure to follow the instructions could result in death or serious injury.
 <b>CAUTION</b>	Failure to follow the instructions could cause personal injury or physical damage to equipment and surroundings.

# TO ENSURE SAFETY

Be sure to also inform users of the following:

For safety, be sure to read the user's manual thoroughly before use, follow it for correct use, and store it so that it can be referenced at any time.

To ensure the safety of your E-BIKE, make sure to also refer to the user's manual for each product such as the battery, battery charger, cycle computer, and switch unit.

## WARNING

- **Be sure to follow the instructions provided in the manuals when installing the product.**

Only use SHIMANO genuine parts. If a component or replacement part is incorrectly assembled or adjusted, it can lead to component failure and cause the rider to lose control and crash.

-  Wear approved eye protection while performing maintenance tasks such as replacing components.
- For information on products not explained in this manual, refer to the manuals for each product.

Be sure to also inform users of the following:

- Do not disassemble or modify the product. This may cause the product to not operate correctly, and you may suddenly fall and be seriously injured.

### ■ Riding precautions

- Be sufficiently familiar with how to start the power assisted bicycle before riding on busy streets. You may start the bicycle unexpectedly, which may result in an accident.
- Be careful not to let the hemming of your clothes get caught in the chain while riding.

You may fall and be seriously injured.

- Keep your fingers away from the chainrings, sprockets, and chain.

They can be seriously injured if caught in the drive train. For DU-EP801 and DU-EP600, please note that when FREE SHIFT is enabled, the chainrings may rotate due to the operation of the drive unit, even when you are not pedaling.

- Ensure that head and tail lights can turn on before riding the bicycle.

### ■ Safety precautions

- Do not touch the drive unit when it has been continuously used for a long period of time. The surface of the drive unit becomes hot and could cause burns.

### ■ For installation to the bicycle and maintenance

- Be sure to remove the battery and charging cable before wiring or attaching parts to the bicycle. Failure to do so may cause an electric shock.
- The two crank arm screws should be tightened alternately in stages rather than each fully tightened at once. Use a torque wrench to check that the tightening torques are within the range of 12 - 14 N·m. Also, after riding approximately 100 km (60 miles), use a torque wrench to re-check the tightening torques. Thereafter, continue to check the tightening torques periodically. If the tightening torques are too weak or if the fixing screws are not tightened alternately in stages, the crank arm may come off and the bicycle may fall over, and serious injury may occur as a result.
- Clean the chain with an appropriate chain cleaner regularly. Intervals between maintenance depend on the use and riding circumstances.

- Never use alkali- or acid-based solvents such as rust cleaners. If those solvents are used the chain might break and cause serious injury.

### **CAUTION**

Be sure to also inform users of the following:

#### ■ Riding precautions

- Observe the instructions in the manual for the bicycle in order to ride safely.

#### ■ Safety precautions

- Never modify the system. Doing so may cause a system error.
- Use the product under the supervision of someone responsible for safety, and only as instructed. Do not allow anyone (including children) with reduced physical, sensory, or mental capacity, or those without experience or knowledge, to use the product.
- Do not allow children to play near the product.

### **NOTICE**

Be sure to also inform users of the following:

#### ■ Riding precautions

- Avoid wearing clothing that may get caught in a chain or wheel, as this may cause an accident.

#### ■ Safety precautions

- If any malfunction or trouble occurs, consult the place of purchase.
- For any questions regarding methods of installation and maintenance, please contact your place of purchase.
- Be sure to attach dummy plugs to any unused E-TUBE ports.
- For installation and adjustment of the product, consult the place of purchase.
- The components are designed to be fully waterproofed to withstand wet weather riding conditions. However, do not deliberately place them into water.
- Do not clean the bicycle with a high-pressure wash. If water gets into any of the components, operating problems or rusting may result.
- Do not turn the bicycle upside down. There is a risk of damage to the cycle computer and switch unit.
- Handle the components carefully, and avoid subjecting them to strong shock.
- Although the bicycle still functions as a normal bicycle even when the battery is removed, the light will not turn on if it is connected to the electric power system. Be aware that using the bicycle under these conditions will be considered non-observance of the road traffic laws in Germany.
- When carrying the assist bicycle in a car, remove the battery from the bicycle and place it on a stable surface in the car.
- Contact the place of purchase for updates of the component software. The most up-to-date information is available on the SHIMANO website. For details, refer to the "[Connection and communication with devices](#)" section.
- Products are not guaranteed against natural wear and deterioration from normal use and aging.
- For maximum performance we highly recommend SHIMANO lubricants and maintenance products.

#### ■ Connection and communication with PC

The PC linkage device is needed to connect the bicycle to a PC. Using E-TUBE PROJECT Professional enables you to perform a range of tasks, such as customizing individual components or the entire system, or updating

firmware.

- PC linkage device: SM-PCE02
- E-TUBE PROJECT Professional: PC application
- Firmware: Software inside each component
- Connection and communication with smartphone

Components that support Bluetooth<sup>®</sup> LE are required to connect the bicycle to a smartphone. Using E-TUBE PROJECT Cyclist enables you to perform a range of tasks, such as customizing individual components or the system, or updating firmware.

- E-TUBE PROJECT Cyclist: Application for smartphones
- Firmware: Software inside each component
- Care and maintenance
- Do not use the thinners or harsh solvents to clean the products. Such substances may damage the surface.
- The chainrings and sprockets should be periodically washed with a neutral detergent. In addition, cleaning the chain with neutral detergent and lubricating it can be an effective way of extending the life of the chainrings, sprockets, and the chain.
- Use a damp, well wrung out cloth when cleaning the battery and plastic cover.

■ Assist

The proper level of assistance cannot be achieved unless the proper settings have been made (proper adjustment of the chain tension, etc.), so consult with the place of purchase.

■ Labels

Some of the important information contained in this manual is also indicated on the device label.

**The actual product may differ from the illustration because this manual is intended mainly to explain the procedures for using the product.**

# Anti-tampering function

Be sure to also inform users of the following:

The tampering of peripheral devices related to the drive unit or assist control of e-bikes is prohibited, including both software and hardware modifications. Be sure to convey this information to customers.

Tampering (\*1) may reduce the service life of and even cause extensive damage to the assist control system, bike components including the drive unit, and the bike itself. Furthermore, because modifying this system will likely void the warranties of SHIMANO products, the user may be forced to pay substantial costs to repair or replace items affected by tampering.

SHIMANO E-BIKE SYSTEMS have a sensor that detects tampering and will display error code [E295](#) (refer to the [error and warning codes](#) on [si.shimano.com](#)) when tampering (\*1) is detected. Error code [E295](#) can be temporarily cleared by turning the power off, then on again. However, after the allowable number of times displaying the error code has been exceeded, SHIMANO E-BIKE SYSTEMS will enter Safe Mode ( [E299](#) ). While in Safe Mode ( [E299](#) ), the assist function of the drive unit will stop.

\*1: Tampering refers to the state where a product does not comply with national or regional standards.

For details on error/warning codes, check the latest versions below:



<https://si.shimano.com/error>

# Booklet structure

## ■ User's manual

SHIMANO E-BIKE SYSTEMS user's manuals are split among several booklets, as described below.

The latest manuals are available on our website ( <https://si.shimano.com> ).

Name	Details
<a href="#">SHIMANO E-BIKE SYSTEMS User's Manual</a>	This is the basic user's manual for SHIMANO E-BIKE SYSTEMS. It contains the following content: <ul style="list-style-type: none"> <li>• Quick guide</li> <li>• Basic operations when riding</li> <li>• How to operate assist bicycles that use flat handlebars, such as city, trekking, or MTB type bicycles</li> </ul>
<a href="#">SHIMANO E-BIKE SYSTEMS User's Manual for Drop Handlebar Bicycles</a>	This booklet describes how to operate assist bicycles that use a drop handlebar and are controlled using dual control levers. This should be read along with the SHIMANO E-BIKE SYSTEMS User's Manual.
SHIMANO E-BIKE SYSTEMS Special Battery and Parts User's Manual (Gen.2) ( <a href="#">standard type</a> / <a href="#">type supporting range extender from another company</a> )	It contains the following content: <ul style="list-style-type: none"> <li>• How to charge and handle the SHIMANO E-BIKE SYSTEMS special battery</li> <li>• How to attach and remove the SHIMANO E-BIKE SYSTEMS special battery to the bicycle</li> <li>• Using the satellite charging port</li> <li>• How to read the battery LEDs when charging or during an error</li> </ul>
SHIMANO E-BIKE SYSTEMS Cycle Computer User's Manual ( <a href="#">clamp band type</a> / <a href="#">bracket installation type</a> / <a href="#">switch unit integrated type</a> )	It contains the following content: <ul style="list-style-type: none"> <li>• Method for configuring settings via the main body buttons and switch unit</li> <li>• Wireless communication method (supported models only)</li> </ul>
Switch Unit User's Manual * 1 ( <a href="#">wireless gear shifting type</a> / <a href="#">with LED indicator function</a> / <a href="#">without LED indicator function</a> )	This is the assist switch and shift switch user's manual. It describes switch unit handling and operations.
<a href="#">Satellite System ON/OFF Switch User's Manual</a>	It describes the handling and operations of the satellite system ON/OFF switch.

\* 1 SHIMANO E-BIKE SYSTEMS compatibility with wireless gear shifting will be provided in a future firmware update.

## ■ Dealer's manual



























SHIMANO E-BIKE SYSTEMS dealer's manuals are split among several booklets, as described below.

The latest manuals are available on our website ( <https://si.shimano.com> ).

Name	Details
SHIMANO E-BIKE SYSTEMS Dealer's Manual	<p>This is the basic dealer's manual for SHIMANO E-BIKE SYSTEMS.</p> <ul style="list-style-type: none"> <li>• Overall wiring diagram</li> <li>• Overall flow of operations for installing the SHIMANO E-BIKE SYSTEMS components to an assist bicycle</li> <li>• Installation / removal and maintenance of the drive unit area</li> <li>• Installation / removal of the speed sensor</li> </ul>
<a href="#">SHIMANO E-BIKE SYSTEMS Dealer's Manual for Drop Handlebar Bicycles</a>	<p>It specializes in the following information regarding assist bicycles that use a drop handlebar and are controlled using dual control levers. This should be read along with the SHIMANO E-BIKE SYSTEMS Dealer's Manual.</p> <ul style="list-style-type: none"> <li>• Overall wiring diagram</li> <li>• Cautions to follow when installing the drive unit</li> </ul>
SHIMANO E-BIKE SYSTEMS Special Battery and Parts Dealer's Manual (Gen.2) ( <a href="#">standard type</a> / <a href="#">type supporting range extender from another company</a> )	<p>It contains the following content:</p> <ul style="list-style-type: none"> <li>• How to install the battery mount</li> <li>• How to install the satellite system ON/OFF switch and satellite charging port</li> </ul>
<a href="#">SHIMANO E-BIKE SYSTEMS Cycle Computer and Switch Unit Parts Dealer's Manual (Gen.2)</a>	<p>It contains the following content:</p> <ul style="list-style-type: none"> <li>• Installation and maintenance of the SHIMANO E-BIKE SYSTEMS special cycle computer and switch unit</li> <li>• How to connect to the PC version of E-TUBE PROJECT</li> </ul>
<a href="#">SHIMANO E-BIKE SYSTEMS Chain Device Dealer's Manual</a>	<p>This manual describes the installation and maintenance of the SHIMANO E-BIKE SYSTEMS special chain device.</p>

# List of tools to be used

The following tools are needed for installation/removal, adjustment, and maintenance purposes.

Component	Location used / screw type	Tool
Electric wire	Plug	 /  TL-EW02 / TL-EW300
Speed sensor (EW-SS300)	Mounting screw	 /  4 mm hexagon wrench / hexalobular [#25]
	Magnet fixing screw	 2 Cross head screwdriver [#2]
Speed sensor (EW-SS301 / EW-SS302)	Mounting screw	 10 Hexalobular [#10]
Drive unit	Mounting screw (M8)	- Contact the bicycle manufacturer.
	Drive unit cover	 2 Cross head screwdriver [#2]
Light cable	Light cable mounting screw	 2 Cross head screwdriver [#2]
CAN cable	Plug	 TL-CA100
Chain device	Bracket fixing screw	 3 3 mm hexagon wrench
	Guide fixing screw	 4 4 mm hexagon wrench
Chain case stay	Fixing screw	 3 3 mm hexagon wrench
Chainring unit	Lock ring	 +  TL-FC430+TL-FC32
		 +  TL-FC430+TL-FC33
		 +  TL-FC430+TL-FC36
	Chain guard Arm cover	 2 Cross head screwdriver [#2]
	Chainring	 +  /  TL-FC22 + 5 mm hexagon wrench / hexalobular [#30]
Crank arm	Crank mounting screw	 /  TL-FC16 / TL-FC18
	Crank fixing screw	 5 5 mm hexagon wrench
Chain	Tension adjustment for internal geared hub models	 TL-DUE60

# Installing electrical parts

## SHIMANO E-BIKE SYSTEMS battery management systems and compatibility

There are two generations of the SHIMANO E-BIKE SYSTEMS battery management system: first generation and second generation (Gen.2).

This manual only describes products compatible with Gen.2.

With some exceptions, first-generation and Gen.2 products of SHIMANO E-BIKE SYSTEMS components are not compatible with each other. For details, refer to the compatibility information on the SHIMANO product website (<https://productinfo.shimano.com/#/com>).

The Gen.2 battery and compatible battery mount are marked "Gen.2" as indicated in the figure or have a "Gen.2" label.

Example: BT-EN805-A and compatible battery mount

Location of terminals

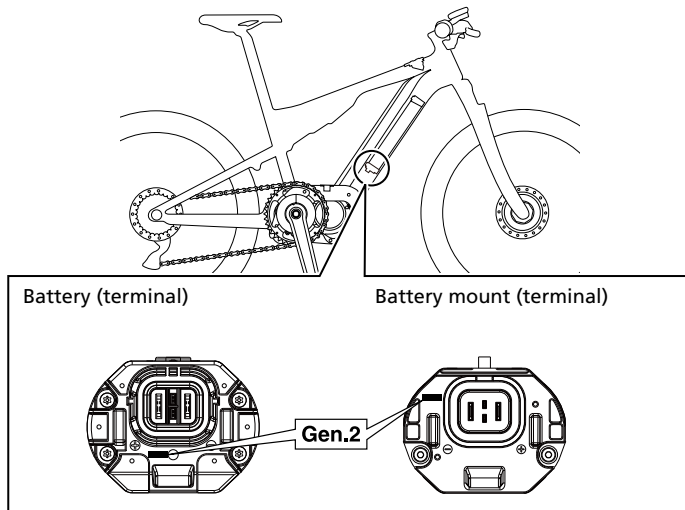

# Names of parts

## External type

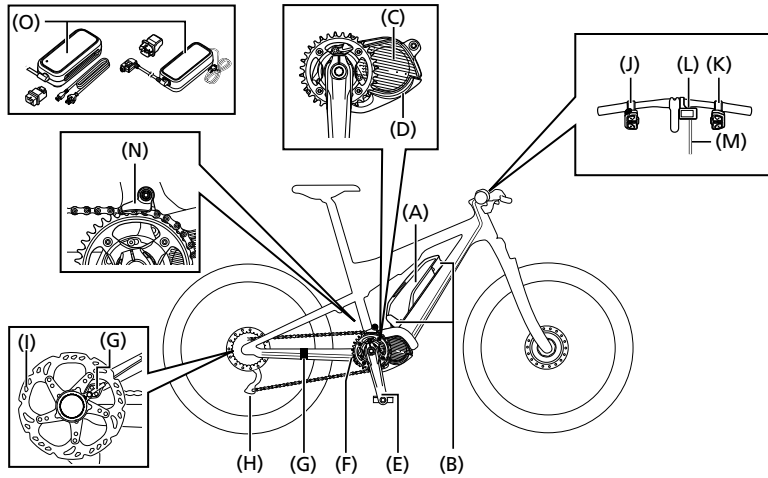

<b>(A)</b>	Battery * <sub>1</sub>	<b>(B)</b>	Battery mount
<b>(C)</b>	Drive unit	<b>(D)</b>	Drive unit cover (left side and bottom side)
<b>(E)</b>	Crank arm	<b>(F)</b>	Chainring unit
<b>(G)</b>	Speed sensor * <sub>2</sub>	<b>(H)</b>	Rear derailleur or internal geared hub * <sub>3</sub>
<b>(I)</b>	Disc brake rotor	<b>(J)</b>	Switch unit (assist switch)
<b>(K)</b>	Switch unit (shift switch) or shifter	<b>(L)</b>	Cycle computer
<b>(M)</b>	Electric wire	<b>(N)</b>	Chain device
<b>(O)</b>	Battery charger		

\*<sub>1</sub> Depending on the frame, the battery may be installed at a location different from the position specified in the figure.

\*<sub>2</sub> Attach it to one of the two locations specified in the figure.

\*<sub>3</sub> Electronic gear shifting: Di2 rear derailleur or motor unit + Di2 internal geared hub

## Integrated type

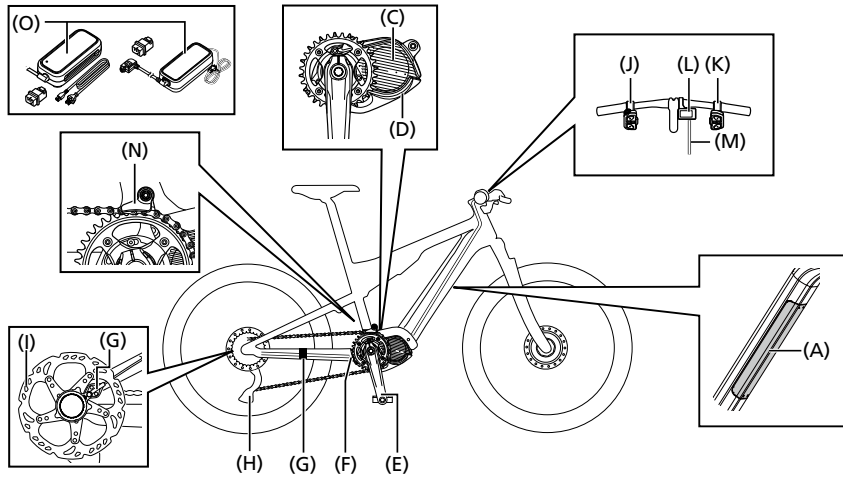

<b>(A)</b>	Battery * <sub>1</sub>	<b>(B)</b>	Battery mount * <sub>1</sub>
<b>(C)</b>	Drive unit	<b>(D)</b>	Drive unit cover (left side and bottom side)
<b>(E)</b>	Crank arm	<b>(F)</b>	Chainring unit
<b>(G)</b>	Speed sensor * <sub>2</sub>	<b>(H)</b>	Rear derailleur or internal geared hub * <sub>3</sub>
<b>(I)</b>	Disc brake rotor	<b>(J)</b>	Switch unit (assist switch)
<b>(K)</b>	Switch unit (shift switch) or shifter	<b>(L)</b>	Cycle computer
<b>(M)</b>	Electric wire	<b>(N)</b>	Chain device
<b>(O)</b>	Battery charger		

\*<sub>1</sub> Attach the battery mount and battery inside the frame. Depending on the frame, the battery may be installed at a location different from the position specified in the figure.

\*<sub>2</sub> Attach it to one of the two locations specified in the figure.

\*<sub>3</sub> Electronic gear shifting: Di2 rear derailleur or motor unit + Di2 internal geared hub

## Rear carrier type

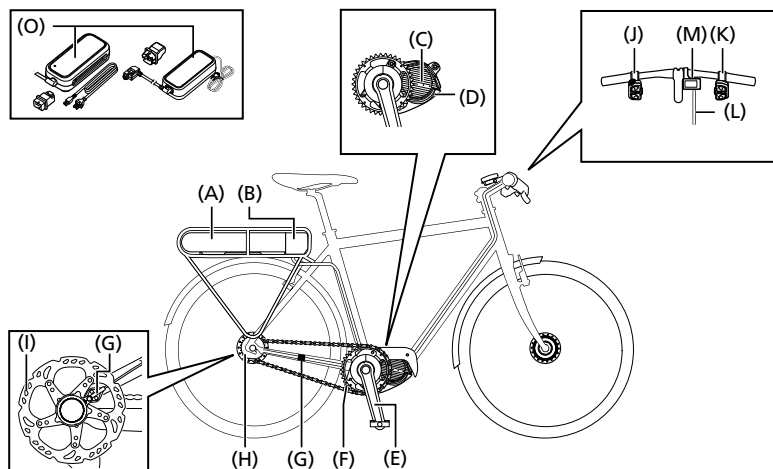

<b>(A)</b>	Battery	<b>(B)</b>	Battery mount
------------	---------	------------	---------------

Installing electrical parts  
Names of parts

(C)	Drive unit	(D)	Drive unit cover (left side and bottom side)
(E)	Crank arm	(F)	Chainring unit
(G)	Speed sensor * <sub>1</sub>	(H)	Rear derailleur or internal geared hub * <sub>2</sub>
(I)	Disc brake rotor	(J)	Switch unit (assist switch)
(K)	Switch unit (shift switch) or shifter	(L)	Electric wire
(M)	Cycle computer	(N)	Battery charger

\* 1 Attach it to one of the two locations specified in the figure.

\* 2 Electronic gear shifting: Di2 rear derailleur or motor unit + Di2 internal geared hub

# Overall wiring diagram

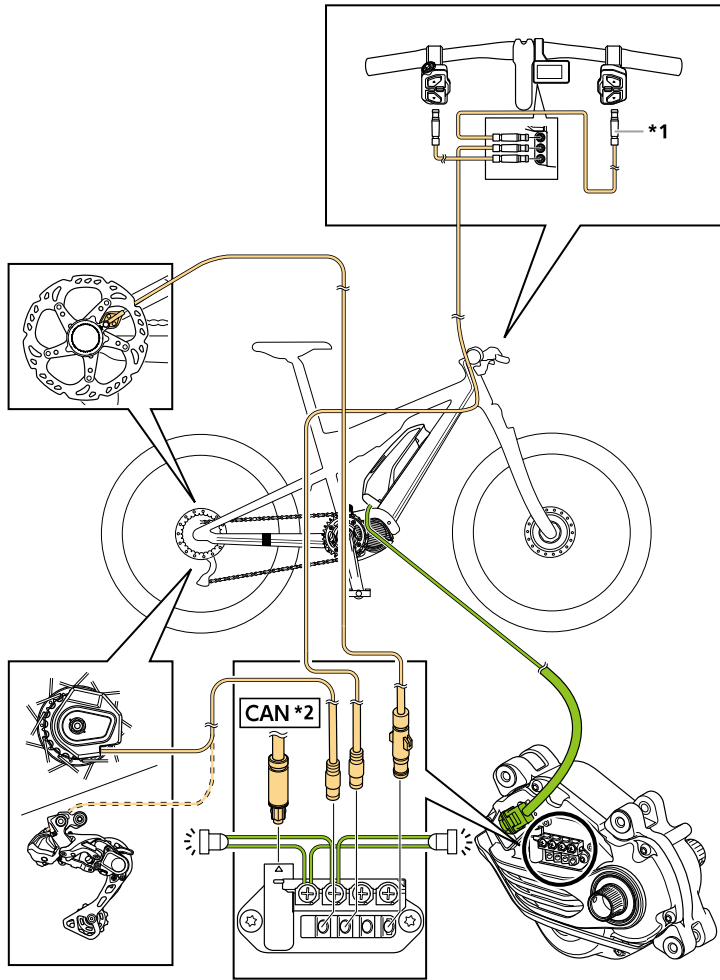

\*1 Wiring not required for wireless gear shifting.

\*2 DU-EP801 and DU-EP600 only.

## **NOTICE**

- The maximum electric wire length between components is 1,600 mm. Ensure that the total length is 1,600 mm or less when connecting via a junction [B] or conversion adapter.

# Specifications

Operating temperature range * 1	-10 - 50°C
Storage temperature * 1	-20 - 70°C
Drive unit type	Midship
Motor type	Brushless DC
Rated drive unit power	250 W

\* 1 These are the temperature specifications of the drive unit alone. The values in the temperature specifications may differ according to the battery and other components used in your E-BIKE. Refer to the user's manual of each product to ensure proper usage and storage.

## TECH TIPS

- The maximum speed provided by assist is set by the manufacturer, but may vary depending on the conditions under which the bicycle is used.

# Electric wires

There are two types of electric wire: the EW-SD300 and the EW-SD50. The supported electric wire differs based on the component model. Check the component specifications on the SHIMANO product website in advance (<https://productinfo.shimano.com/>).

## Supported products

The following products support each type of electric wire.

Product name	Intended purpose	EW-SD300 type	EW-SD50 type
SHIMANO original tool	Connecting / disconnecting the electric wires	TL-EW300	TL-EW02
Dummy plug	Plugging empty ports	Y7HE30000	Y6VE15000
Cord clip	Binding the wiring and the outer casing / brake hose together	EW-CL300-S (for shift outer casing) EW-CL300-M (for outer casing and brake hose)	Y70H98040
Cord cover	Supporting / protecting the electric wire (external wiring)	EW-CC300	SM-EWC2
Grommet	Installing to the wire insertion hole of a frame that supports internal wiring	EW-GM300-S EW-GM300-M	SM-GM01 SM-GM02
Cord band	Supporting the electric wire (flat handlebar external wiring)	EW-CB300-S EW-CB300-M EW-CB300-L	SM-EWE1
Junction [A] (for Di2)	Gathering the wiring around the cockpit. Also has functions for changing the shift mode, etc.	-	EW-RS910 SM-EW90-A SM-EW90-B
Junction [B]	Conjoining the wiring inside and outside the frame	EW-JC304 EW-JC302	SM-JC41 SM-JC40 EW-JC200 EW-JC130
Conversion adapter	Refer to the " <a href="#">Conversion adapter</a> " section	EW-AD305	EW-AD305

**NOTICE**

- The SHIMANO original tool used for installation/removal and the accessories used for wiring differ for the EW-SD300 and EW-SD50. Be sure to use a compatible product.
- EW-CL300-S is marked with a groove in order to differentiate it from EW-CL300-M.

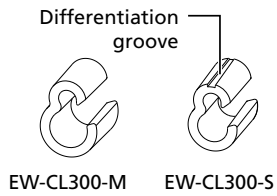

## Conversion adapter

A conversion adapter (EW-AD305) is required to connect the EW-SD50 to a component with an E-TUBE port for the EW-SD300.

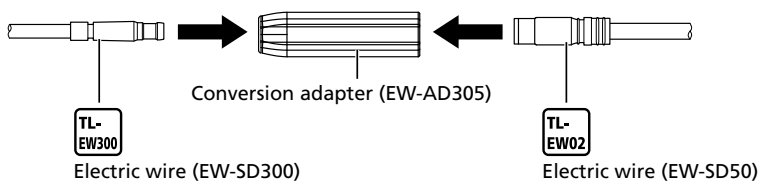

## Connecting/disconnecting the electric wires

Be sure to use the SHIMANO original tool to remove and insert electric wires.

### NOTICE

- When connecting and disconnecting electric wires, do not forcibly bend the plug part. It may result in a poor connection.

## Connecting the electric wire (EW-SD300)

Connect the electric wire to the E-TUBE port.

### 1. Set the plug of the electric wire to the TL-EW300.

If there is an alignment tab on the plug of the electric wire, check the shape of the E-TUBE port you are trying to connect to, and set it aligned with the alignment tab as shown in the figure.

Without alignment tab on plug

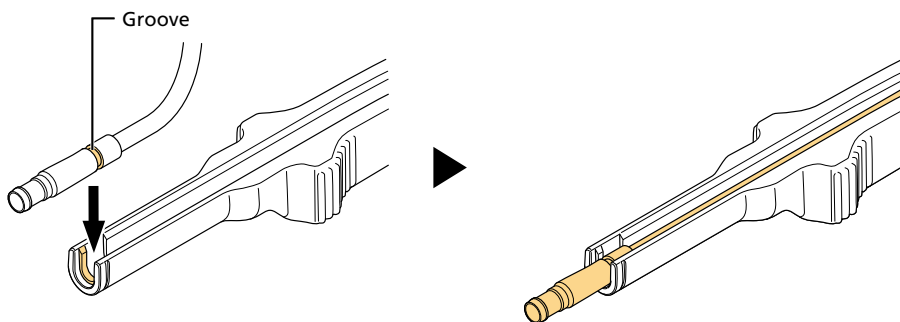

With alignment tab on plug

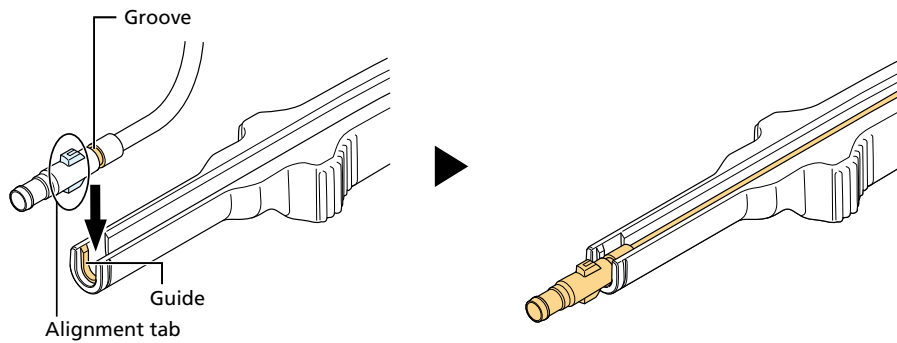

**2. Insert the plug on the electric wire into the E-TUBE port.**

Push it straight in until you feel a click.

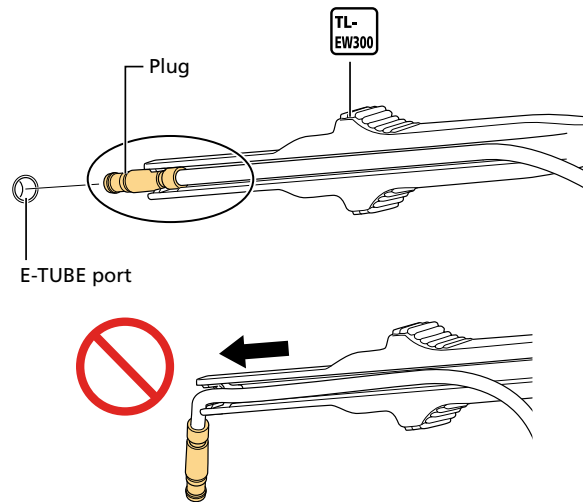

**TECH TIPS**

- When connecting the EW-SD300, the method below can also be used.

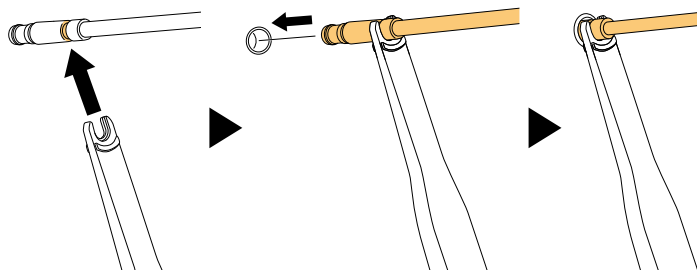

**Removing the electric wire (EW-SD300)**

**1. Disconnect the electric wire.**

- (1) Insert the TL-EW300 into the groove on the plug part of the electric wire.
- (2) Disconnect the electric wire from the E-TUBE port.

\* As shown in the figure, use part (A) of the TL-EW300 as a fulcrum, move the tool like a lever, then disconnect the plug part.

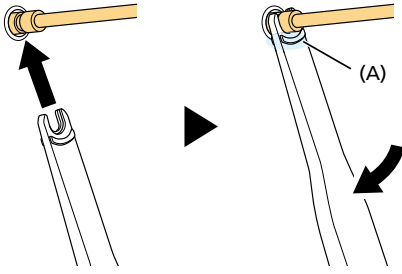

### TECH TIPS

- If there is limited space to insert the tool, you can use the TL-EW300 as indicated in the figure to disconnect the electric wire.

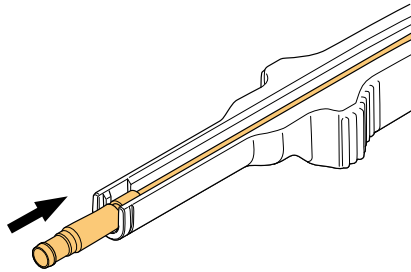

## Connecting the electric wire (EW-SD50)

Connect the electric wire to the E-TUBE port.

### 1. Set the plug of the electric wire to the TL-EW02.

If there is an alignment tab on the plug of the electric wire, set it aligned with the groove on the SHIMANO original tool.

Without alignment tab on plug

With alignment tab on plug

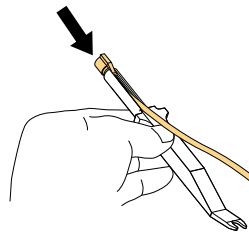
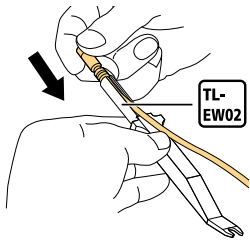

### 2. Insert the plug on the electric wire into the E-TUBE port.

Push it straight in until you feel a click.

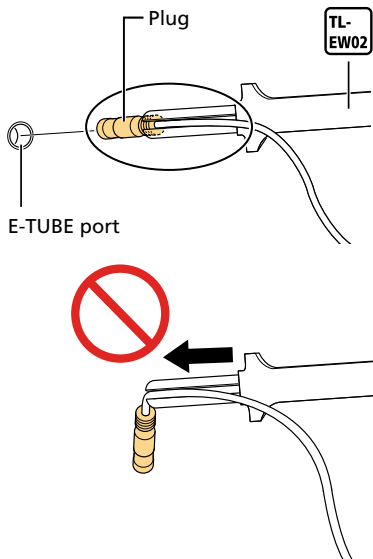

## Removing the electric wire (EW-SD50)

### 1. Disconnect the electric wire.

- (1) Insert the TL-EW02 into the groove on the plug of the electric wire.
- (2) Disconnect the electric wire from the E-TUBE port.

\* As shown in the figure, use part (A) of the TL-EW02 as a fulcrum, move the tool like a lever, then disconnect the plug part. If there is limited space to insert the tool, lift the TL-EW02 straight up and disconnect the electric wire.

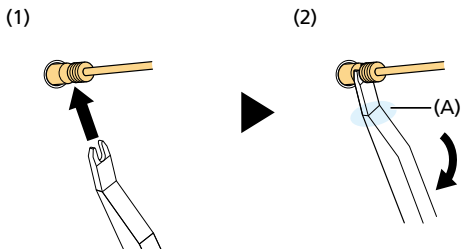

# Installing cockpit peripheral components

Refer to the “ [SHIMANO E-BIKE SYSTEMS Cycle Computer and Switch Unit Parts Dealer's Manual \(Gen.2\)](#).”

# Installing the battery mount and parts

Refer to the following manuals:

- SHIMANO E-BIKE SYSTEMS Special Battery and Parts Dealer's Manual (Gen.2) [Standard type](#)
- SHIMANO E-BIKE SYSTEMS Special Battery and Parts Dealer's Manual (Gen.2) [Type supporting range extender from another company](#)

# Installing the speed sensor

## NOTICE

- For details on the compatibility of the speed sensor and drive unit, refer to the compatibility information (<https://productinfo.shimano.com/#/com>).

## Generic type

For model: EW-SS300 (SD300 type)

The generic type speed sensor can be installed regardless of the type of brake, such as rim brake, roller brake, or coaster brake. Install the magnet on a spoke on the rear wheel.

## NOTICE

- Refer to the installation angle in the figure when installing a generic type speed sensor. It may not operate correctly if it is installed with the position of the  $\Delta$  marking exceeding the allowed range.

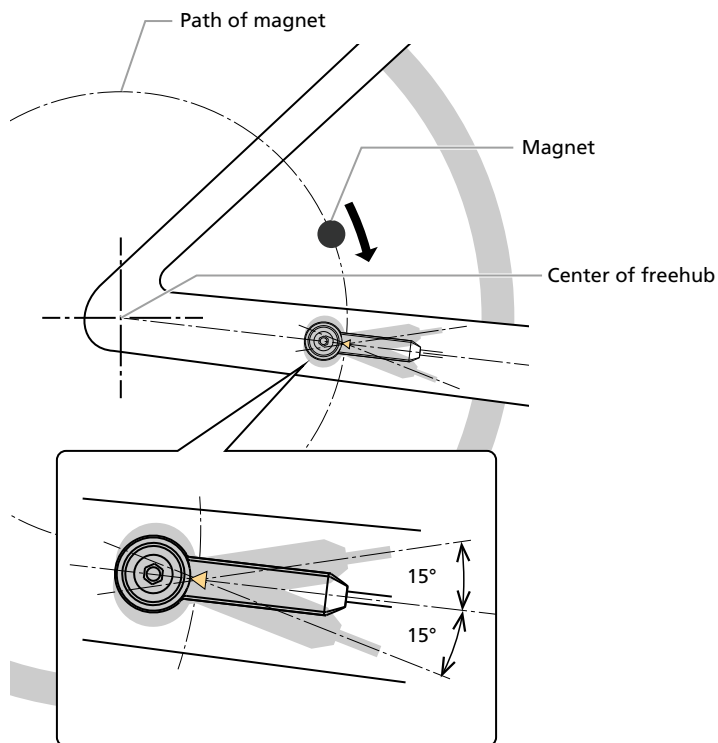

### 1. Temporarily install the magnet to the spoke.

Determine the installation position of the magnet so that the center of the magnet is aligned with the tip of the  $\Delta$  marking on the speed sensor.

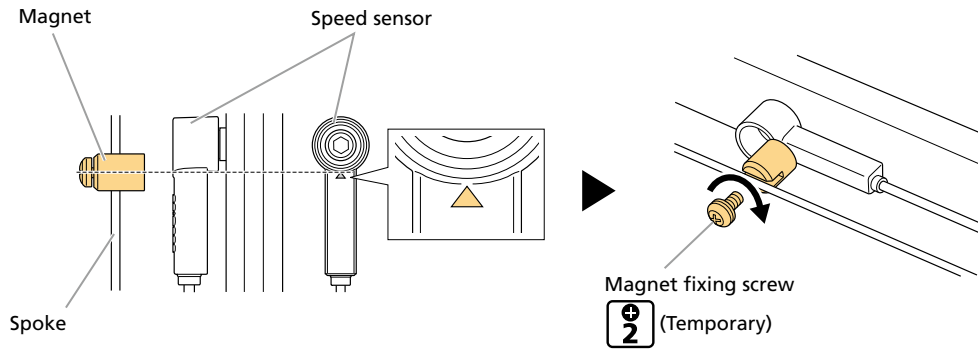

**2. Install the speed sensor.**

**Clearance between speed sensor and magnet is 3 to 17 mm**

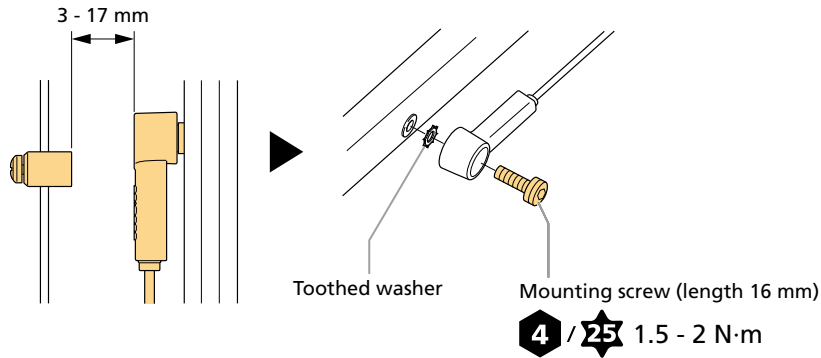

**Clearance between speed sensor and magnet exceeds 17 mm**

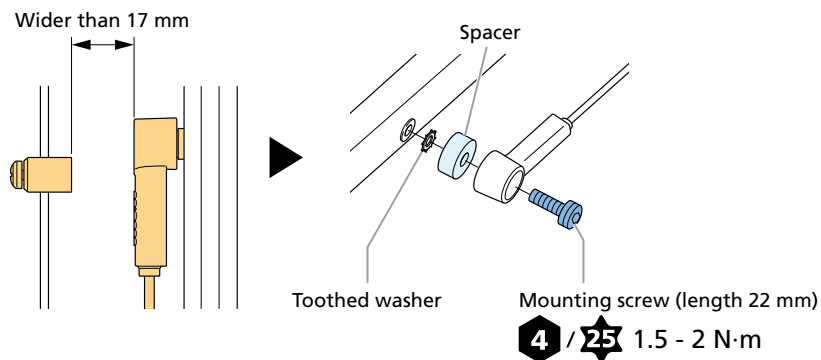

**3. Secure the magnet.**

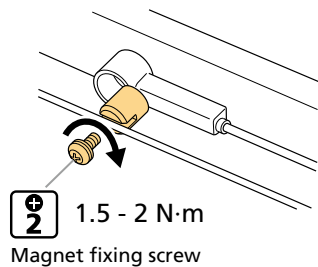

**4. Route the electric wire for the speed sensor to the frame along the chainstay and wire it to the drive unit.**

**Type designed exclusively for use with a rotor with magnet**

For model: EW-SS301 (SD300 type)

Use in combination with a rotor with magnet (rear wheel only).

**1. Install the rotor to the wheel.**

- Refer to the “Disc Brake” chapter of [General Operations](#) for the installation method.
- The rotor with magnet is the internal spline type. Install it using the TL-LR15 SHIMANO original tool.

**2. Install the speed sensor to the frame.**

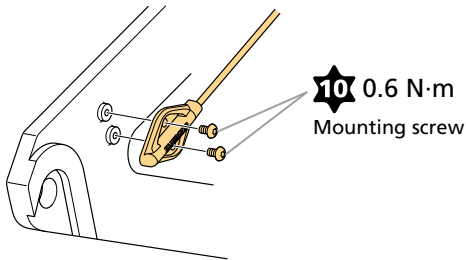

**3. Affix the wire for the speed sensor to the chainstay and wire it to the drive unit.**

**4. Install the rear wheel in the frame.**

## Type designed exclusively for use with a lock ring with magnet

For model: EW-SS302

Use in combination with a rotor (rear wheel only) secured with a lock ring with magnet.

### TECH TIPS

- For details on rotors that have a lock ring with magnet, check the SHIMANO product website (<https://productinfo.shimano.com/>).

**1. Install the rotor to the wheel using the lock ring with magnet.**

- Refer to the “Disc Brake” section of [General Operations](#) for the installation method.
- The lock ring with magnet is the internal spline type. Install it using the TL-LR15 SHIMANO original tool.

**2. Install the speed sensor to the frame.**

Insert the protrusion of the speed sensor into the frame, and secure the speed sensor.

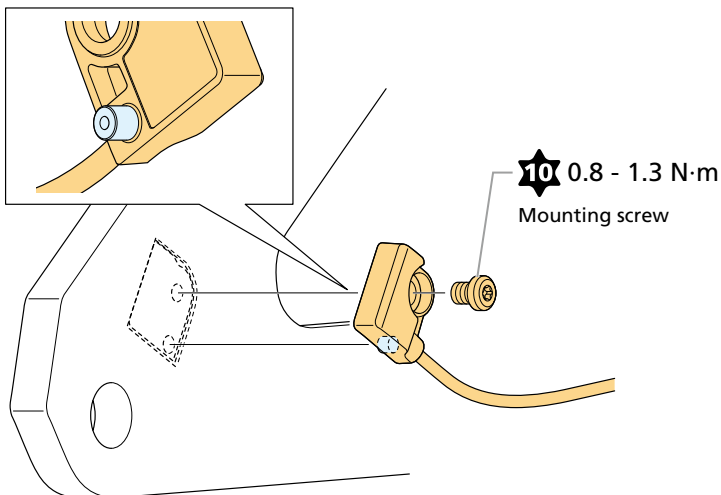

**3. Affix the wire for the speed sensor to the chainstay and wire it to the drive unit.**

**4. Install the rear wheel in the frame.**

# Installing the drive unit and peripheral parts

## Introduction

Use the following procedure to install the drive unit and peripheral parts:

- (1) Installing the drive unit
- (2) Connecting the wires to the drive unit
- (3) Installing the drive unit cover
- (4) Installing the chainring unit and crank arms

### TECH TIPS

- To check the wiring of the drive unit on a completed bicycle, you will need to first remove the drive unit cover. Remove the left cover to access the power cord and terminal block.

# Installing the drive unit

Before installing the drive unit to the frame, first check that all the wires that connect to the drive unit have been routed to the drive unit installation area.

## NOTICE

- Mounting screws (M8) are not included with SHIMANO products. Use the screws supplied by the bicycle manufacturer.
- The recommended tightening torque may differ according to the frame accuracy and the material and surface treatment of the screws. To avoid damage to the frame, consider the strength of the drive unit installation area before installation.
- Unless otherwise stated, DU-EP801 is used as an example.

### 1. Tighten the mounting screws on the right side so that the drive unit makes firm contact with the inner surface on the right side of the frame.

Make sure to secure it from the right side to ensure an accurate chain line. Failure to do so may affect gear shifting performance.

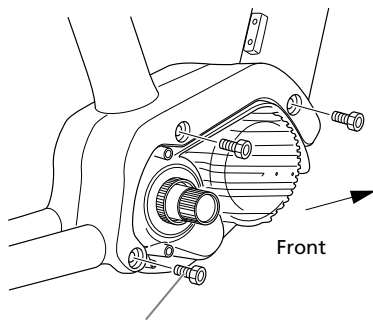

11.2 - 12.5 N·m

Mounting screw (M8)

### 2. Tighten the mounting screws on the left side of the frame.

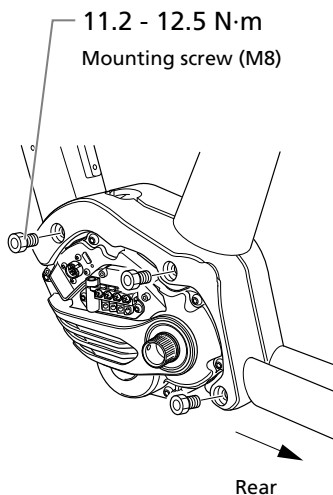

11.2 - 12.5 N·m

Mounting screw (M8)

# Connecting the power cord

## Connection method

1. Connect the power cord while paying attention to the orientation of the power plug and power port.

\* Check that it is securely connected.

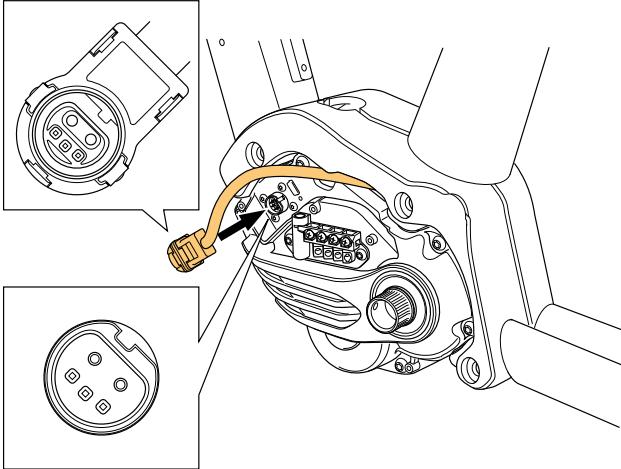

### NOTICE

- Confirm that the power plug and power port are facing each other and insert straight into the power port along the fitting axle. Inserting the power plug at an angle or while changing the direction it is facing may cause the pin of the power port to become deformed or bent.

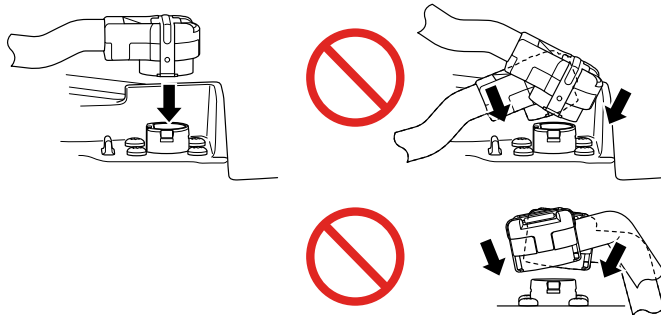

## Removal method

1. Remove the power cord.

Pulling out the handle as indicated in the figure will make it easier to remove.

Installing the drive unit and peripheral parts  
Connecting the power cord

---

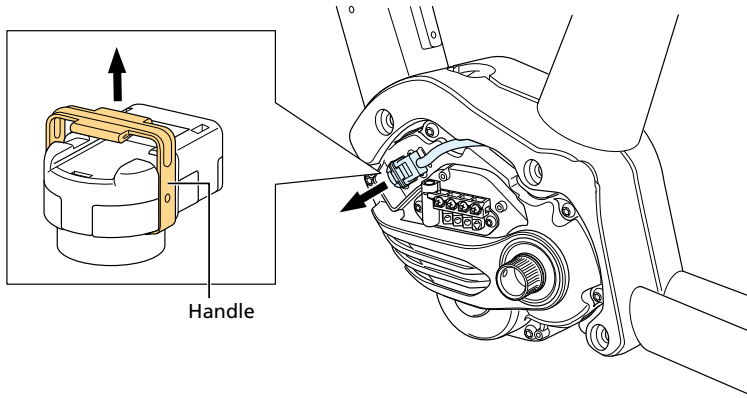

# Connecting cockpit peripheral parts and electronic gear shifting components

Connect wires from the cycle computer and electronic gear shifting components to the drive unit's terminal block.

## 1. Connect the electric wires to the drive unit's E-TUBE ports.

### DU-EP801 / DU-EP600

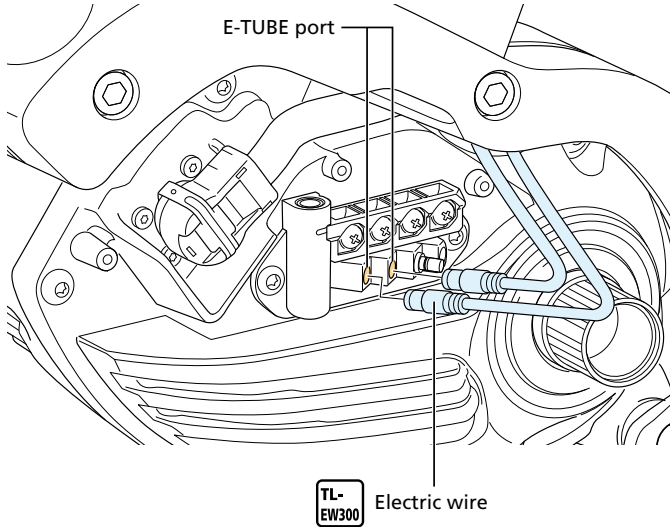

### DU-EP500

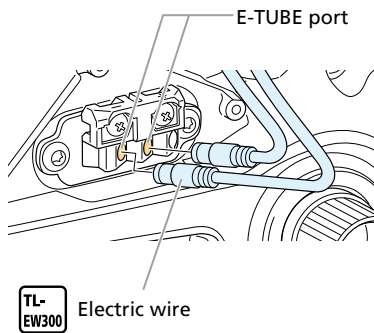

## NOTICE

- Be sure to attach dummy plugs to any unused E-TUBE ports.

# Connecting the speed sensor

Connect the speed sensor's electric wire to the drive unit's terminal block.

1. Connect the electric wire to the drive unit's speed sensor port.

## DU-EP801 / DU-EP600

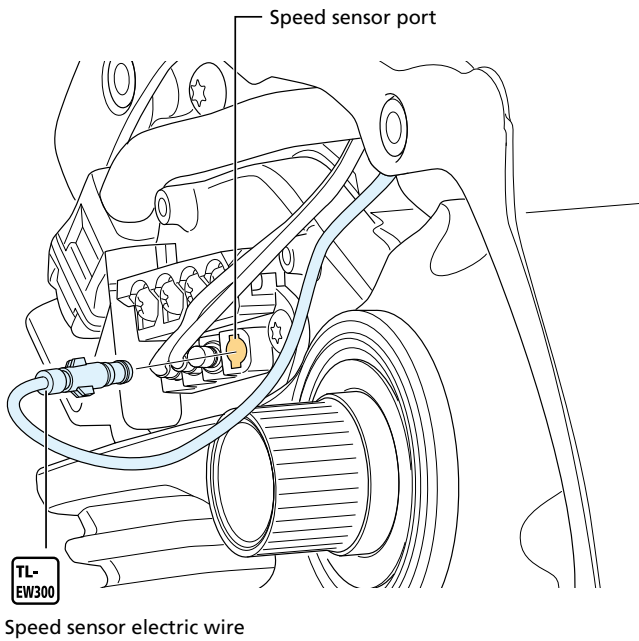

## DU-EP500

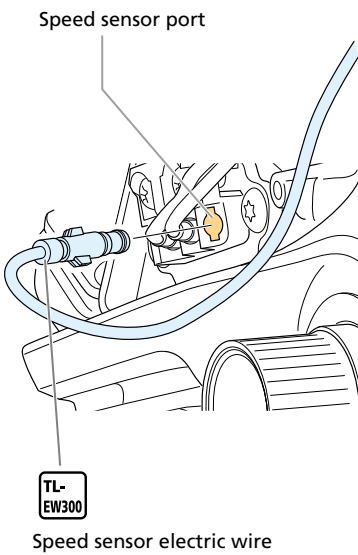



# Connecting the light cables

Connect the wires connected to the front and rear lights to the drive unit.

## 1. Loosen the light cable mounting screws.

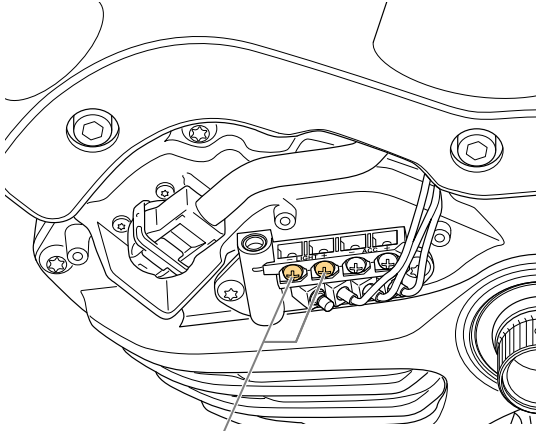
DU-EP801 / DU-EP600



 Light cable mounting screw

DU-EP500

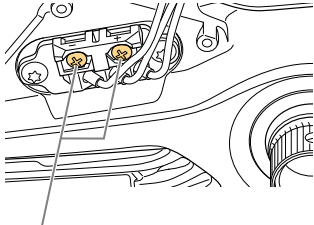

 Light cable mounting screw

## 2. Connect the light cables to the light connection terminals.

DU-EP801 / DU-EP600

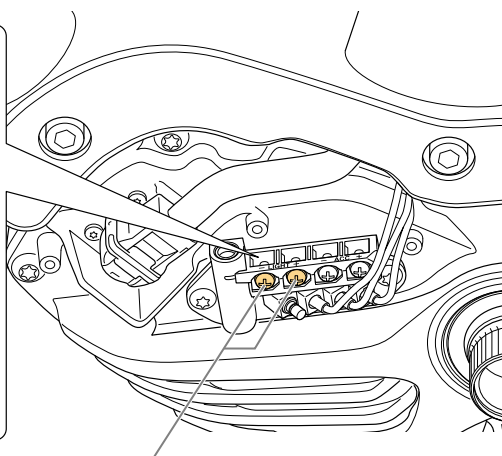
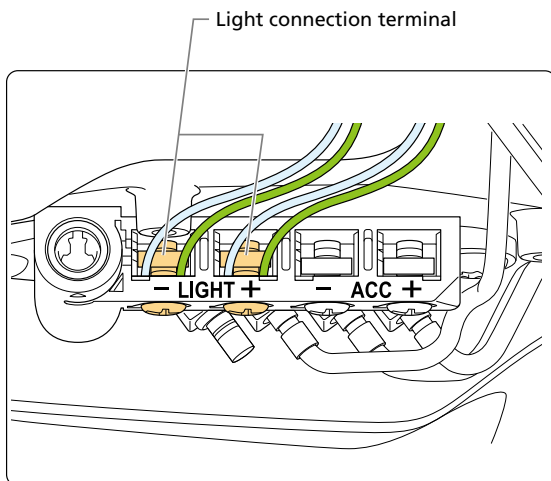

 0.6 N·m  
Light cable mounting screw

### DU-EP500

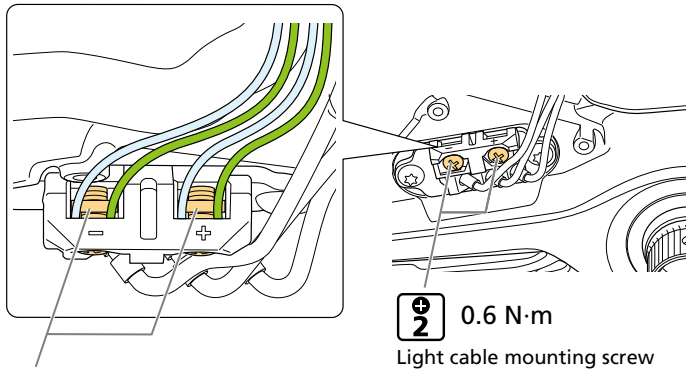

Light connection terminal

 0.6 N·m  
Light cable mounting screw

### TECH TIPS

- With DU-EP801 or DU-EP600, if there is any optional part other than lights and the ABS that requires power, connect it to the connection terminal with the ACC mark.

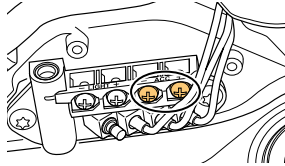

# Connecting the CAN cable

For models: DU-EP801 / DU-EP600

When connecting a product from another company to the drive unit, connect a CAN cable with the dedicated plug to the CAN port. Be sure to use the SHIMANO original tool to remove and insert the CAN cable to this product.

## NOTICE

- Do not forcibly bend the plug part. It may result in a poor contact.
- A CAN dummy plug is connected to the CAN port when the drive unit is shipped. Leave the dummy plug connected when the CAN port is unused.

## Connecting the CAN cable

1. Align the position of the  $\Delta$  marking on the plug of the CAN cable and the  $\Delta$  marking on the drive unit, then insert the plug straight on.

CAN cable

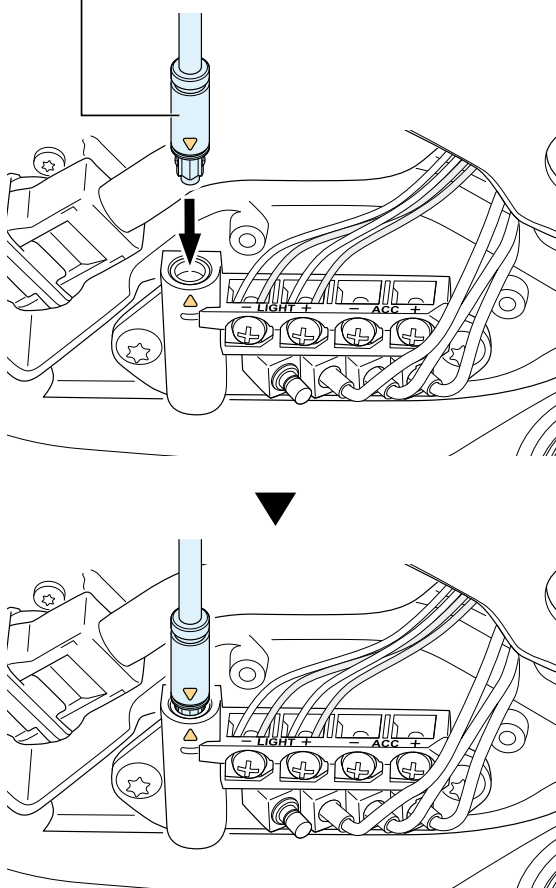

## NOTICE

- Gently insert the plug of the CAN cable into the port straight. Forcing the plug of the CAN cable in at an angle may damage the CAN port.

## 2. Connect the CAN cable.

- (1) Insert the TL-CA100 into the groove on the plug part of the CAN cable.
- (2) Gently insert the CAN cable until you feel a click.

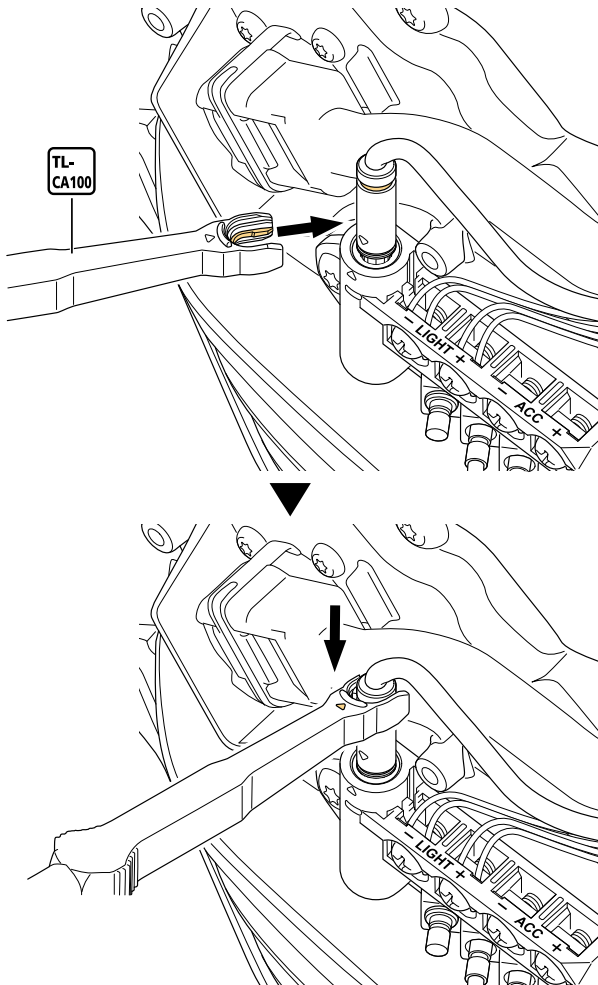

### TECH TIPS

- It may be possible to connect the CAN cable in the method below, depending on the structure of the frame. Be aware that the plug part of the CAN cable is prone to being at an angle to the CAN port.
- (1) Set the plug of the CAN cable to the TL-CA100. Align the position of the  $\Delta$  marking on the TL-CA100 and the  $\Delta$  marking on the plug of the CAN cable.

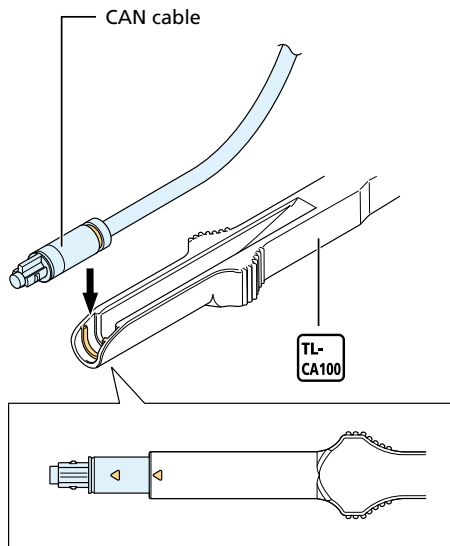

- (2) Align the position of the  $\Delta$  marking on the TL-CA100 and the  $\Delta$  marking on the drive unit, then gently insert the cable straight on until you feel a click.

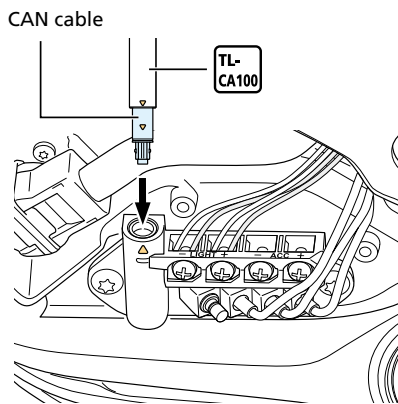

## Removing the CAN cable

1. Insert the TL-CA100 into the groove on the plug part of the CAN cable.  
Insert the TL-CA100 into the plug part using the method (A) or (B).

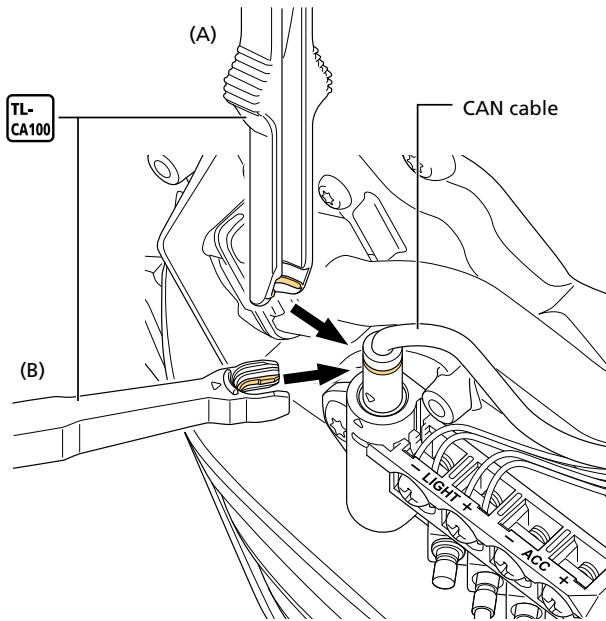

**2. Remove the CAN cable.**

Pull it out straight using the method (A) or (B).

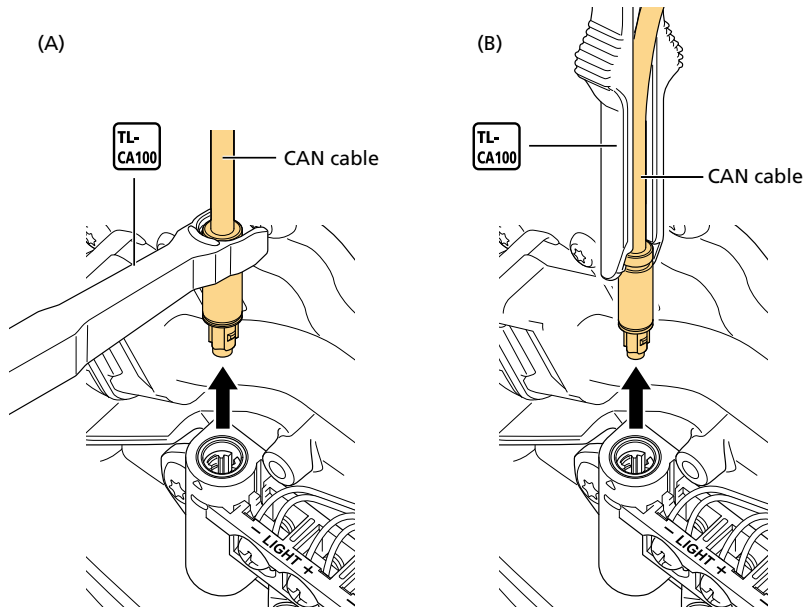

# Installing the drive unit cover

- The appearance of the drive unit cover differs depending on the model, but the installation method is the same.
- When also using a drive unit cover from another company, refer to the manual for the frame.

## NOTICE

- Magnesium is used for DU-EP801 cover installation area. Use cover fixing screws designated for use with magnesium components included with DU-EP801. If parts other than those designated for use with magnesium components are used, the rusting process will accelerate.

### 1. Install the left cover.

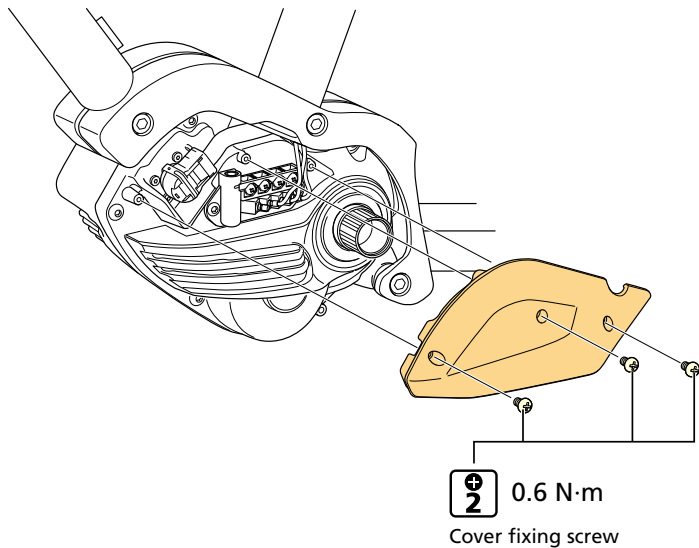

### 2. Install the guard.

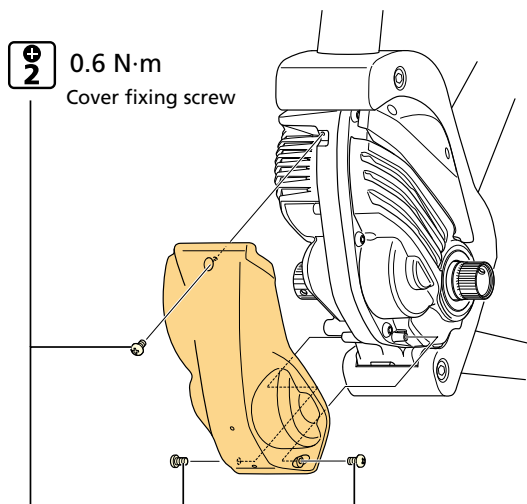

## Affixing the thermal hazard label

A thermal hazard label is affixed to the position shown in the figure on the guard.

For bicycles that use a drive unit cover from another company, refer to the position shown in the figure to affix

Installing the drive unit and peripheral parts  
Installing the drive unit cover

---

the thermal hazard label included with the drive unit to a visible location around the motor fins.

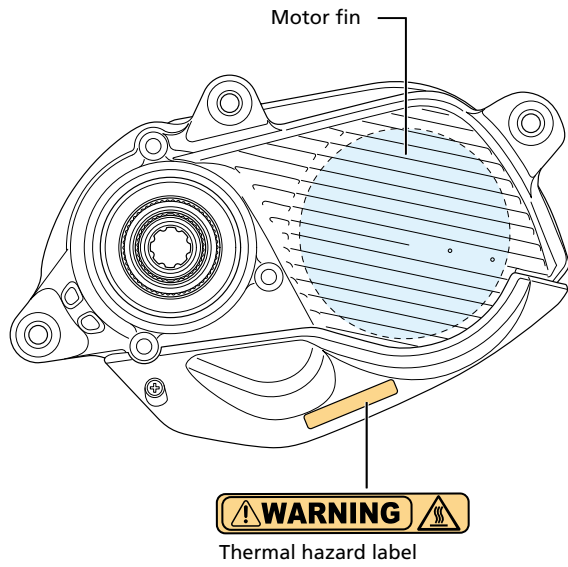

# Installing the chainring unit and crank arms

Install the rear wheel in the frame prior to performing the following procedures.

## 1. Set the left crank arm.

- (1) Check that the stopper plate on the left crank arm is sticking out.
- (2) Align the position of the crank arm and the axle, as indicated in the figure.
- (3) Tighten the crank mounting screw.

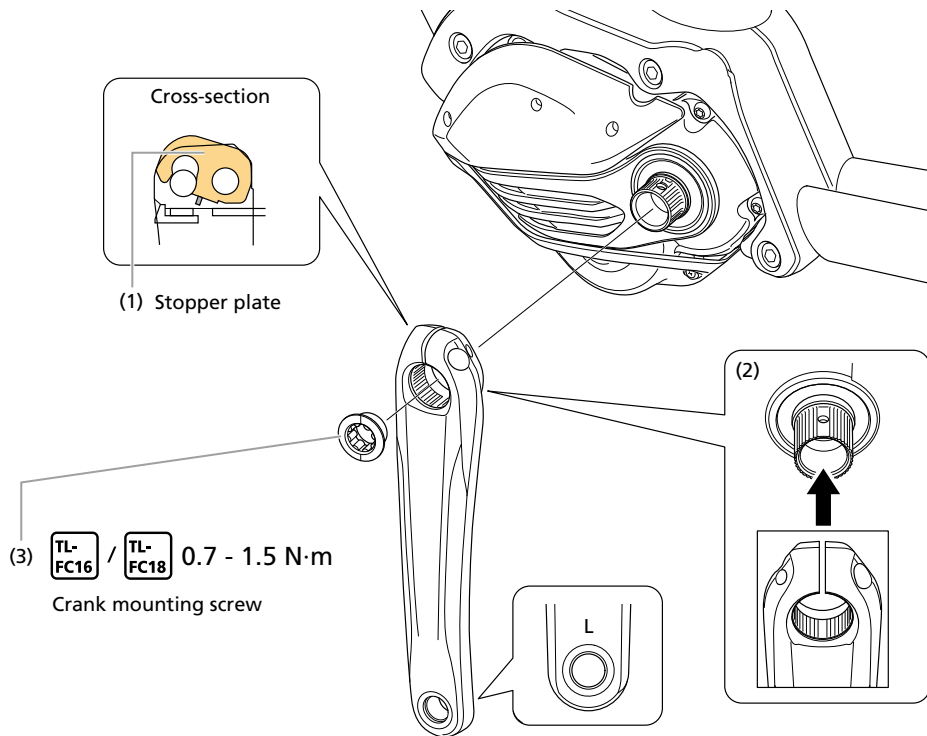

## 2. Secure the left crank arm.

- (1) Press the stopper plate in.  
\* Check that the plate pin is firmly engaged.
- (2) Tighten both crank fixing screws alternately and equally to the specified tightening torque.

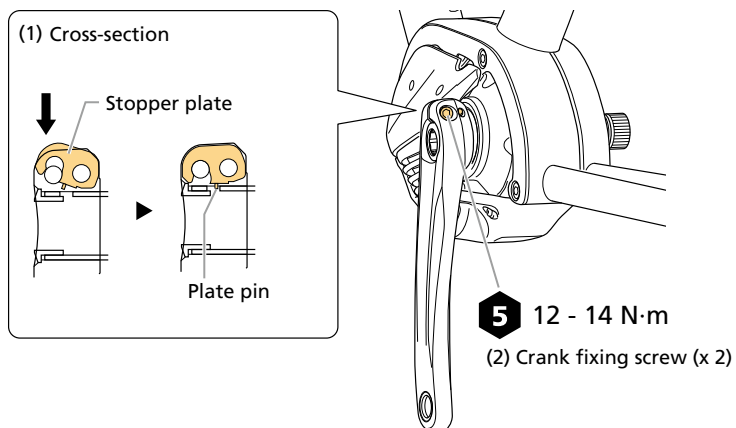

**NOTICE**

- Set the stopper plate in the correct direction as shown in the figure. For the left crank arm, the figure depicts the part as looking from the back of the bicycle.

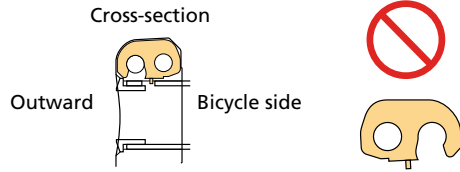

### 3. Install the chain device or chain case.

If not required, proceed to the next step.

#### When installing the chain device

Refer to the "[SHIMANO E-BIKE SYSTEMS Chain Device Dealer's Manual](#)."

#### When installing the chain case

Chain cases and chain case stays are not included with SHIMANO products.

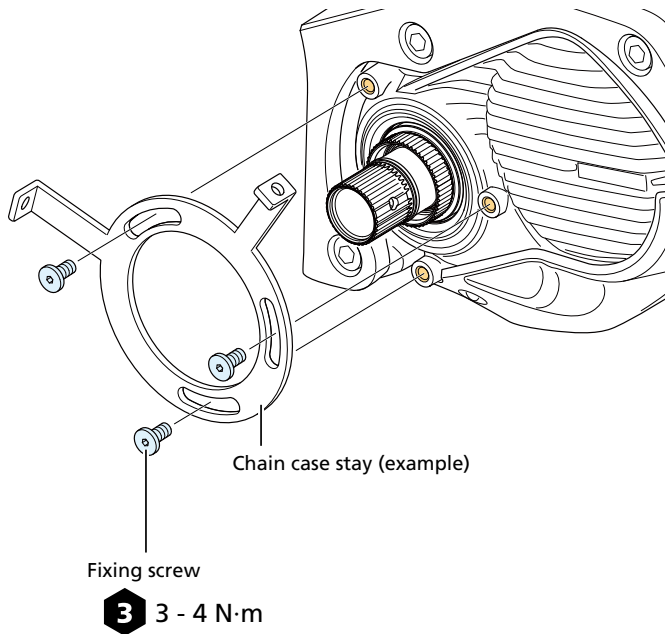

## NOTICE

- The chain device and chain case stay use the same mounting hole. They cannot be installed at the same time.
- Magnesium is used for DU-EP801 chain device/chain case stay installation area. Use fixing screws designated for use with magnesium components included with DU-EP801. If parts other than those designated for use with magnesium components are used, the rusting process will accelerate.

### 4. Install the chainring unit.

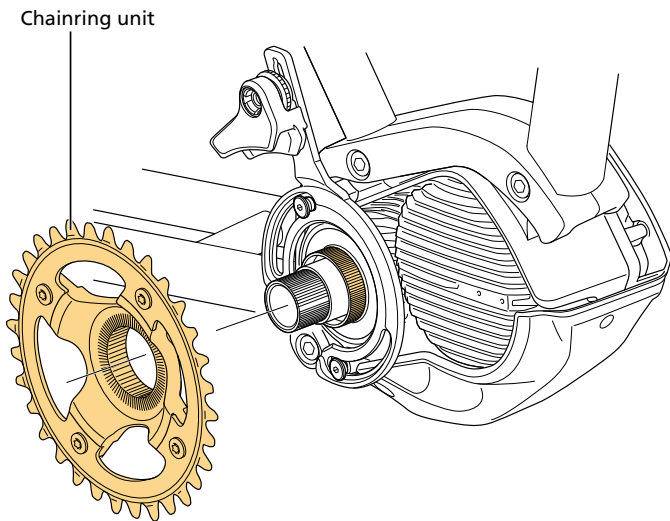

**5. Install the chain.**

Refer to the dealer's manual for the chain to use.

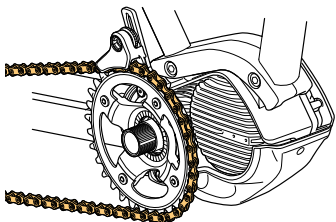

**6. Secure the chainring unit.**

- (1) Install the lock ring (left-hand thread) by hand.
- (2) Tighten the lock ring while holding the left crank arm stable.

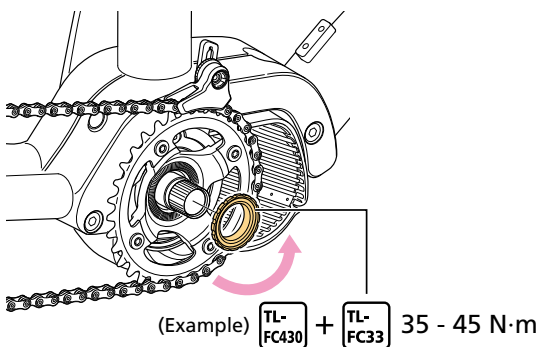

When tightening the lock ring, the combination of tools indicated in the table below can be used in addition to the above.

Tool combinations		
TL-FC430 + TL-FC32	TL-FC430 + TL-FC33	TL-FC430 + TL-FC36

**NOTICE**

- Do not use an impact wrench.

**7. As with the left crank arm, set the right crank arm and tighten the crank mounting screw.**

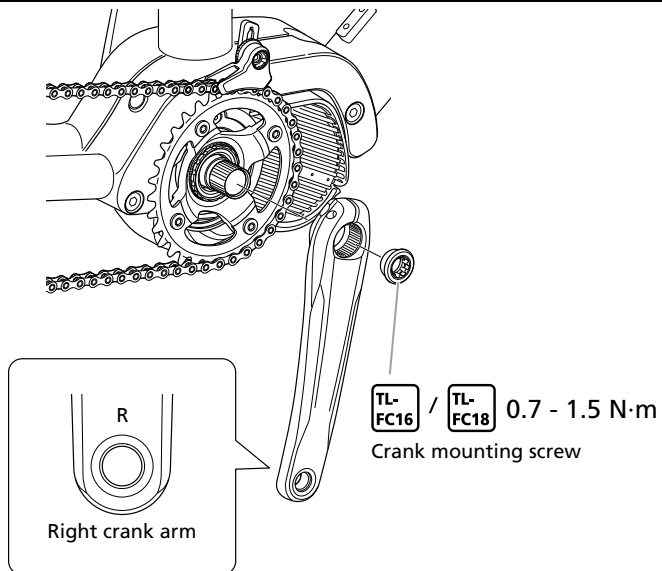

### 8. Secure the right crank arm.

- (1) Press the stopper plate in.
  - \* Check that the plate pin is firmly engaged.
- (2) Tighten both crank fixing screws alternately and equally to the specified tightening torque.

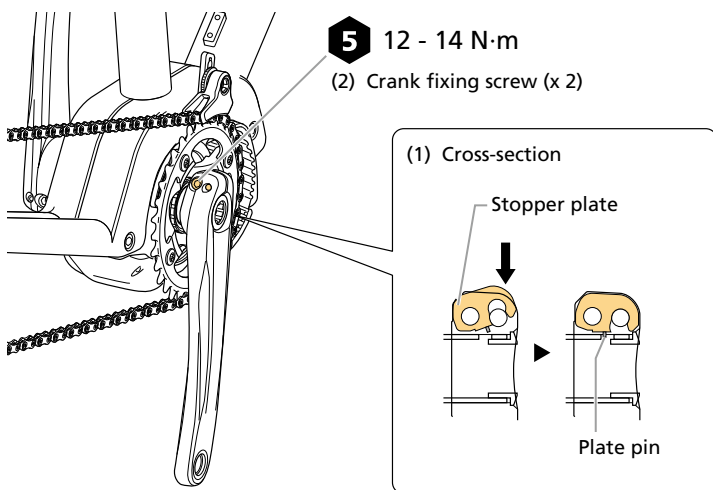

## NOTICE

- Set the stopper plate in the correct direction as shown in the figure. For the right crank arm, the figure depicts the part as looking from the back of the bicycle.

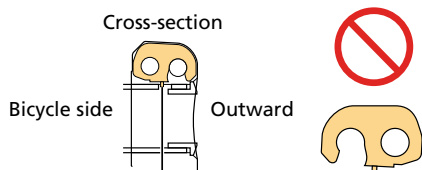

# Installing the arm covers

If arm covers are included with the chainring, install the arm covers after installing the chainring to the drive unit.

## 1. Install the arm covers to the left and right sides of the chainring.

Install so that the hooks catch the spider arm on the chainring.

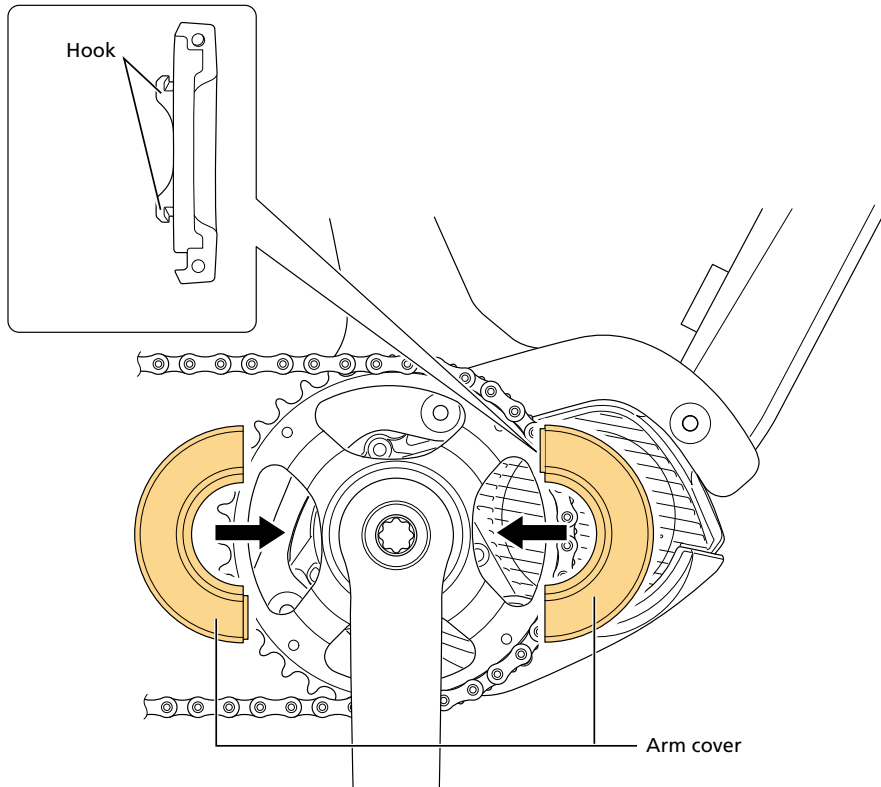

## 2. Tighten the two arm cover fixing screws from the left and right.

For internal geared hub models, proceed to "[Measuring and adjusting the chain tension](#)."

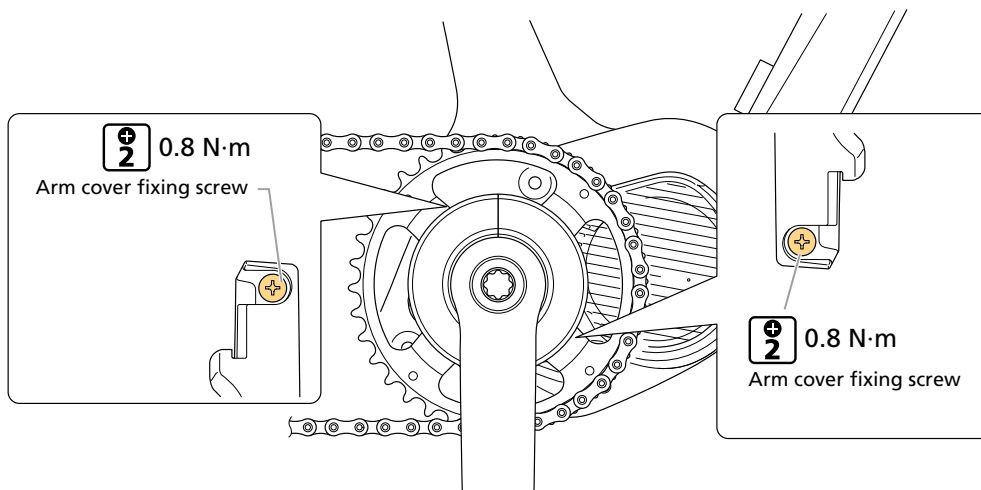

# Measuring and adjusting the chain tension

The chain tension must be adjusted for internal geared hub models.

## NOTICE

- The proper level of assistance may not be achieved if the chain tension is too high.

## Manual adjustment

### 1. Check and adjust the chain tension.

Pull the upper side of the chain up and down with a force of approximately 10 N (1 kgf), roughly in the middle between the drive unit axle and rear wheel axle. Adjust the chain tension so that the chain has a slack of 15 mm or more.

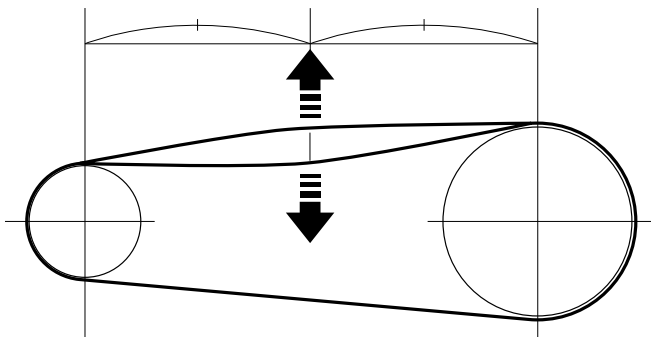

## Measuring and adjusting with TL-DUE60

When using chain tension measurement tool TL-DUE60, you can measure and adjust the chain tension from either the top or bottom of the chain.

### Measuring and adjusting from the upper side of the chain

#### 1. Set TL-DUE60.

- (1) Set TL-DUE60 to the upper side of the chain.
- (2) Push TL-DUE60 down, and make it touch the chainring and rear sprocket.

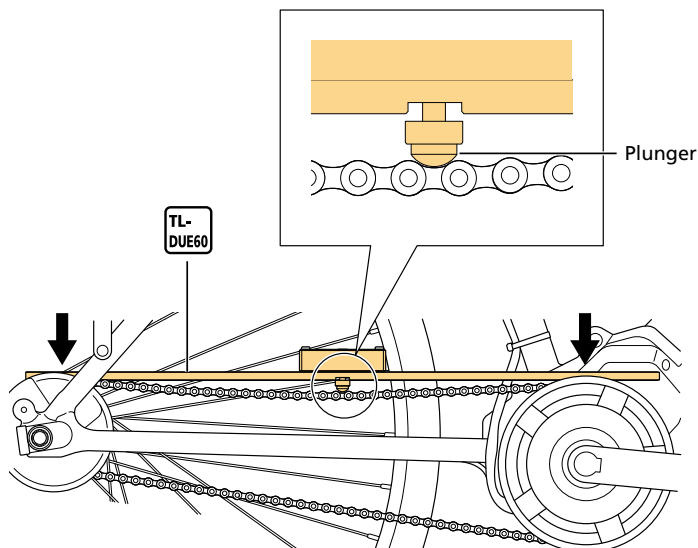

**2. Adjust the chain tension so the plunger depresses slightly.**

Make sure the top of the plunger does not stick out of the top of the frame.

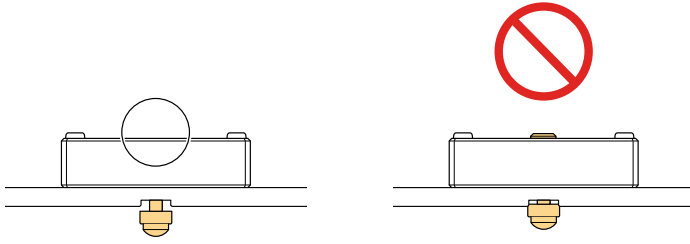

**Measuring and adjusting from the lower side of the chain**

**1. Set TL-DUE60.**

- (1) Set TL-DUE60 to the lower side of the chain.
- (2) Push TL-DUE60 up, and make it touch the chainring and rear sprocket.

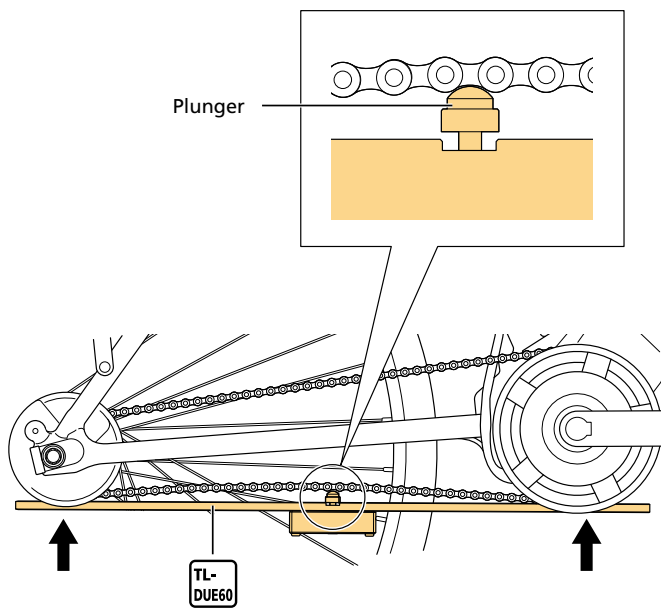

**2. Adjust the chain tension so the plunger depresses slightly.**

Make sure that the flange of the plunger does not sink into the hollow of the frame.

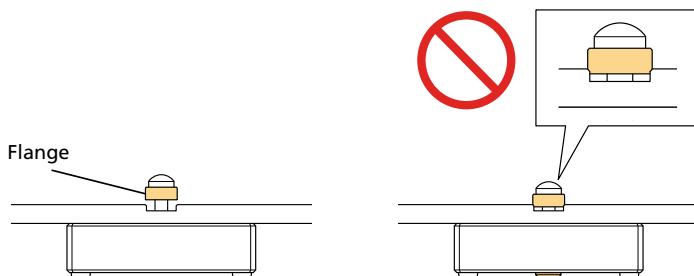

# Connection and communication with devices

Connecting the bicycle to a device allows you to configure the system, update firmware, and more. Refer to the "SHIMANO E-BIKE SYSTEMS Cycle Computer User's Manual ( [clamp band type](#) / [bracket installation type](#) / [switch unit integrated type](#) )" and " [SHIMANO E-BIKE SYSTEMS Special Cycle Computer and Switch Unit Parts Dealer's Manual \(Gen.2\)](#) ."

# Maintenance

## Replacing the chainring unit

When replacing the chainring unit, make sure that the chain is attached.

Refer to “ [Installing the chainring unit and crank arms](#) ” for detailed instructions.

1. **Remove the right crank arm.**
2. **Remove the lock ring (left-hand thread).**

Hold the rear wheel firmly while removing the lock ring to keep the chainring from turning.

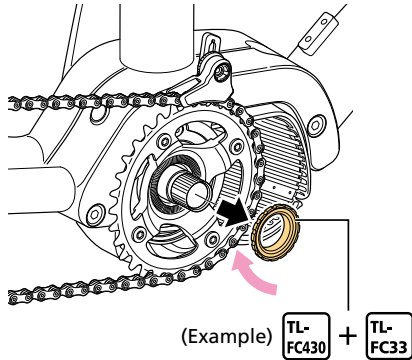

When removing the lock ring, the combination of tools indicated in the table below can be used in addition to the above.

Tool combinations		
TL-FC430 + TL-FC32	TL-FC430 + TL-FC33	TL-FC430 + TL-FC36

3. **Remove the chainring unit.**
4. **Prepare a new chainring unit.**

### For models that allow standalone chainring replacement

Remove the chainring from the 4-arm adapter, then install a new chainring.

Install the chainring so that “INSIDE” or the printed model name is on the inside.

Tighten 4 chainring fixing bolts alternately and equally to the specified tightening torque.

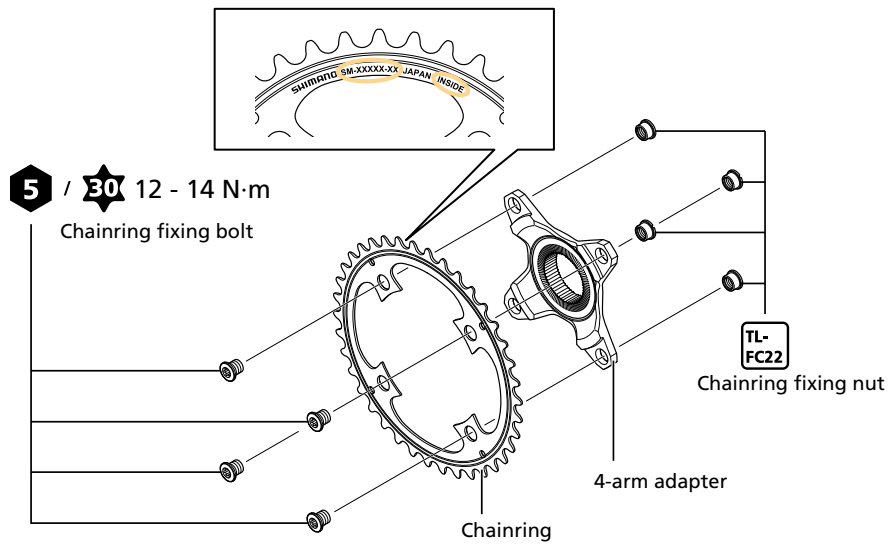

**For models with an integrated chainring and adapter**

Proceed to the next step.

5. Refer to "[Installing the chainring unit and crank arms](#)" to install a new chainring unit to the drive unit.

# Replacing the chain guard

To replace the chain guard, first remove the chainring unit from the bicycle.

Refer to "[Replacing the chainring unit](#)" for information on how to remove the chainring unit.

1. Remove the chainring unit.
2. Remove the chain guard then replace it with a new chain guard.

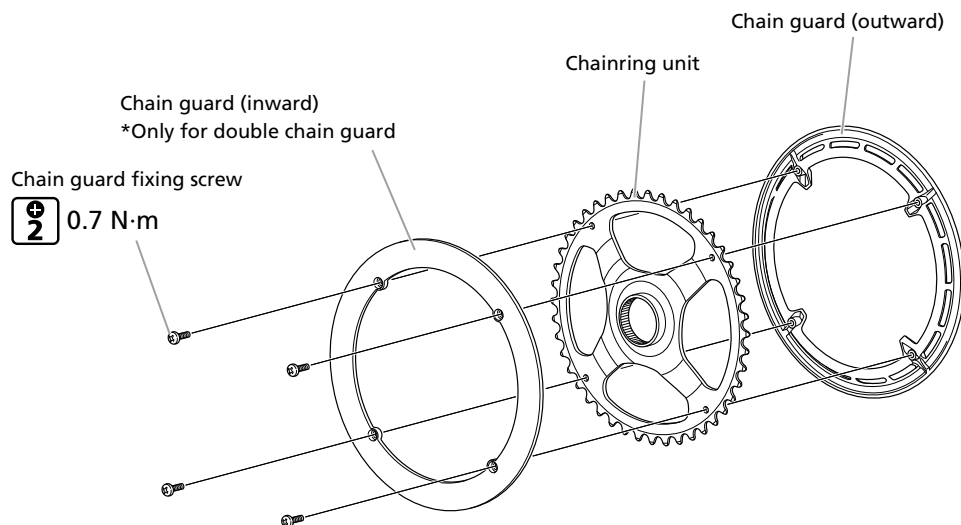

3. Refer to "[Installing the chainring unit and crank arms](#)" to install the chainring unit to the drive unit.

## Replacing the arm cover

The arm cover can be replaced with the chainring unit attached to the drive unit. Refer to “ [Installing the arm covers.](#)”

# SHIMANO

**SHIMANO NORTH AMERICA BICYCLE, INC.**  
One Holland, Irvine, California 92618, U.S.A. Phone: +1-949-951-5003

**SHIMANO EUROPE B.V.**  
High Tech Campus 92, 5656 AG Eindhoven, The Netherlands Phone: +31-402-612222  
Only EU General Contact : [contactshimano@shimano-eu.com](mailto:contactshimano@shimano-eu.com)

**SHIMANO INC.**  
3-77 Oimatsu-cho, Sakai-ku, Sakai City, Osaka 590-8577, Japan

Please note: specifications are subject to change for improvement without notice. (English)  
© Dec. 2024 by SHIMANO INC. ITP