

## Dealer's Manual

ROAD	MTB	Trekking
City Touring/ Comfort Bike	URBAN SPORT	E-BIKE

# Chain

### Non-Series

CN-LG500

SM-CN900-11

# Contents

---

<b>Contents .....</b>	<b>2</b>
<b>IMPORTANT NOTICE .....</b>	<b>3</b>
<b>TO ENSURE SAFETY .....</b>	<b>4</b>
<b>List of tools to be used.....</b>	<b>8</b>
<b>Installation/removal .....</b>	<b>9</b>
<b>Checking the chain length.....</b>	<b>9</b>
<b>Cutting the chain.....</b>	<b>9</b>
<b>Connecting the chain .....</b>	<b>10</b>
• Connecting pin .....	10
• QUICK-LINK.....	11
<b>Removing the QUICK-LINK .....</b>	<b>12</b>



# IMPORTANT NOTICE

- **This dealer's manual is intended primarily for use by professional bicycle mechanics.** Users who are not professionally trained for bicycle assembly should not attempt to install the components themselves using the dealer's manuals. If any part of the information on the manual is unclear to you, do not proceed with the installation. Instead, contact your place of purchase or a distributor for assistance.
- Make sure to read all manuals included with the product.
- Do not disassemble or modify the product other than as stated in the information contained in this dealer's manual.
- All manuals and technical documents are accessible online at <https://si.shimano.com>.
- For consumers who do not have easy access to the internet, please contact a SHIMANO distributor or any of the SHIMANO offices to obtain a hardcopy of the User's Manual.
- Please observe the appropriate rules and regulations of the country, state or region in which you conduct your business as a dealer.

**For safety, be sure to read this dealer's manual thoroughly before use, and follow it for correct use.**

The following instructions must be observed at all times in order to prevent personal injury and physical damage to equipment and surroundings.

The instructions are classified according to the degree of danger or damage which may occur if the product is used incorrectly.

 <b>DANGER</b>	Failure to follow the instructions will result in death or serious injury.
 <b>WARNING</b>	Failure to follow the instructions could result in death or serious injury.
 <b>CAUTION</b>	Failure to follow the instructions could cause personal injury or physical damage to equipment and surroundings.

# TO ENSURE SAFETY

## ⚠ WARNING

- **Be sure to follow the instructions provided in the manuals when installing the product.** Only use SHIMANO genuine parts. If a component or replacement part is incorrectly assembled or adjusted, it can lead to component failure and cause the rider to lose control and crash.
-  Wear approved eye protection while performing maintenance tasks such as replacing components.

## Be sure to also inform users of the following:

- Install the chain to face the correct way. In order to achieve good gear shifting performance, CN-LG500 has a front side and a reverse side and must be fitted in the correct orientation. For best chain performance make sure it is installed to face the correct way. If it is installed so that it faces the opposite way, the chain may come off and the bicycle may fall over and serious injury may occur as a result.
- Do not reuse a QUICK-LINK that has been removed. If the QUICK-LINK is reused, there is a risk that the connection will loosen and become detached, which could cause the rider to lose control of the bicycle and fall.
- Clean the chain and QUICK-LINK with an appropriate chain cleaner regularly. Intervals between maintenance depend on the use and riding circumstances. Never use alkali based or acid based solvents, such as rust cleaners. If those solvents are used the chain or QUICK-LINK might break and cause serious injury.
- If it is necessary to readjust the length of the chain due to a change in the sprocket configuration, etc., cut the chain in a place other than where it has been connected by a QUICK-LINK or reinforced connecting pin. The chain or chain cutter will be damaged if the chain is cut at a place where it is connected with a QUICK-LINK or reinforced connecting pin.

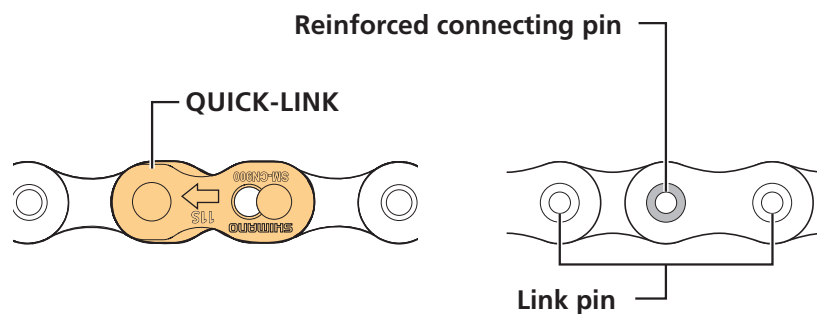

- Check the chain and QUICK-LINK for any damage (deformations or cracking), chain skipping, or other abnormalities such as unintended gear shifting. If any problems are found, consult your place of purchase or a distributor. There is a risk of the chain breaking or the QUICK-LINK detaching, which may cause you to fall off the bicycle.
- When replacing the chain with a new one, be sure to replace the QUICK-LINK with a new one as well. If the QUICK-LINK is not replaced, it may become damaged and you may fall off the bicycle.
- When installing the QUICK-LINK, make sure that the QUICK-LINK pins are inserted securely as far as they will go.

**For installation to the bicycle, and maintenance:**

- Only use the tool and connecting pin / QUICK-LINK models specified in the table to connect the chain. If an unsuitable connecting pin / QUICK-LINK and tool are used to connect the chain, insufficient connecting force may cause chain separation or skipping.

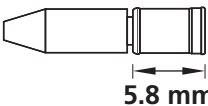
Chain	Connecting pin / QUICK-LINK	Tool (chain assembly)	Tool (chain cutter)
All 11-speed chains / CN-LG500	SM-CN900-11 	TL-CN10	TL-CN28, TL-CN34
		TL-CN28, TL-CN34	

- Install so that the arrow on the surface is pointing in the rotation direction of the crank when viewed from the front. If it is not installed correctly, the QUICK-LINK could detach, which may cause you to fall off the bicycle.

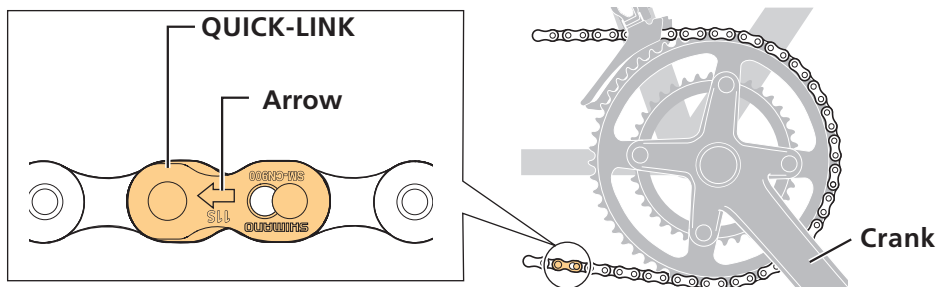

- When readjusting the length of the chain, be sure to insert the reinforced connecting pin from the same side that the chain cutter was inserted (the same direction as when the chain was cut).

## ■ Reinforced connecting pin

- Make sure that the connecting pin is as shown in the figure after adjustment. (The pin will protrude slightly after the break off pin is removed.)

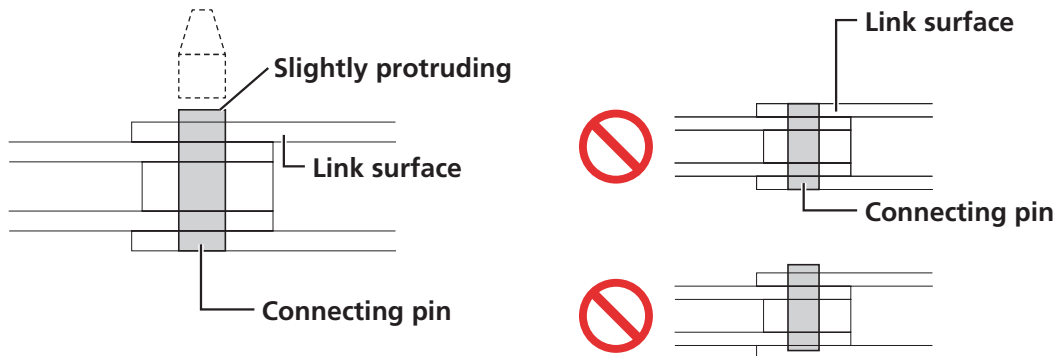

## NOTICE

### Be sure to also inform users of the following:

- The gears should be periodically washed with a neutral detergent then lubricated. In addition, cleaning the chain and QUICK-LINK with a neutral detergent and lubricating them can be an effective way of extending the life of the chain and QUICK-LINK.
- A SHIMANO original tool is required to remove the QUICK-LINK. Consult your place of purchase or a distributor.
- Products are not guaranteed against natural wear and deterioration from normal use and aging.
- For maximum performance we highly recommend SHIMANO lubricants and maintenance products.

## For installation to the bicycle, and maintenance:

- As illustrated in figure [A], we strongly recommend to set the connecting pin in the hole of the outer link on the front side in the direction of travel. The chain's level of strength is enhanced compared to the method in figure [B].

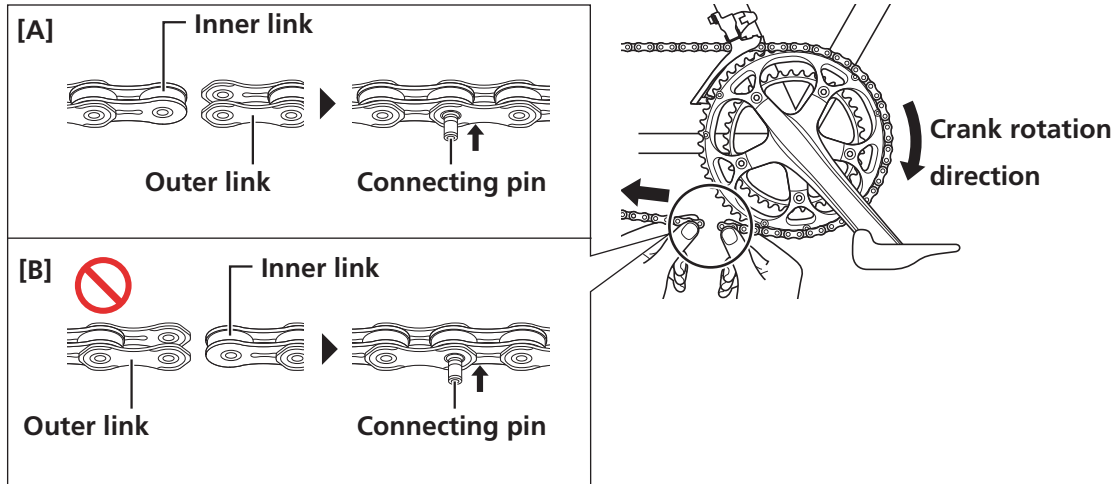

- In order to achieve good gear shifting performance, this chain has a front side and a reverse side and must be fitted in the correct orientation.
- Front (outer side)  
The side with the mark shown in the figure is the front (outer side).







- Reverse (inner side)



The actual product may differ from the illustration because this manual is intended mainly to explain the procedures for using the product.

# List of tools to be used

The following tools are needed for installation/removal, adjustment, and maintenance purposes.

Tool	
	TL-CN10
	TL-CN28
	TL-CN29
	TL-CN34
	TL-CN35



# Installation/removal

## Checking the chain length

Refer to the dealer's manual of the rear derailleur for the method to check the length of the chain.

## Cutting the chain

If the chain is too long, use the chain cutter and cut the chain.

### 1. Place the chain in the chain cutter.

#### NOTICE

- Set the chain on the chain cutter as shown in the figure when using the chain cutter. If the chain cutter is used without properly placing the chain, the positioning plate may be damaged.

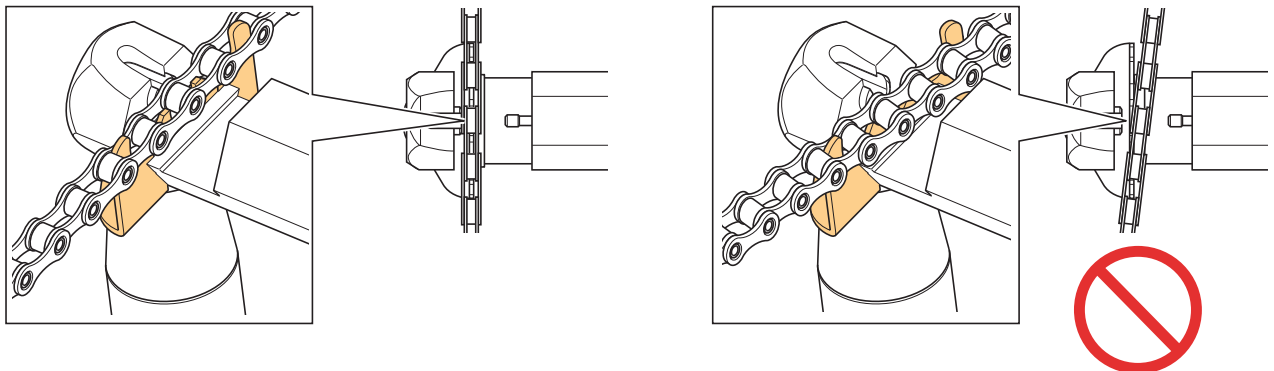

### 2. Turn the handle of the chain cutter to push out the pin.

Push the center of the pin to completely remove the pin from the chain.

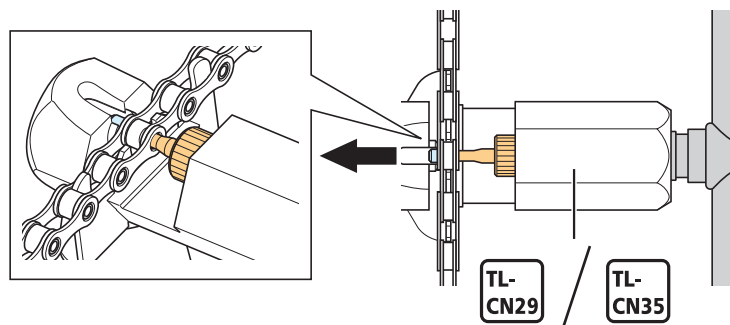

# Connecting the chain

## Connecting pin

1. Insert the connecting pin.

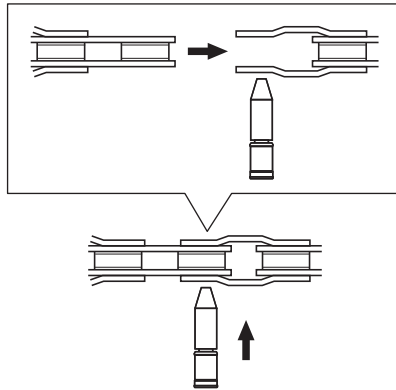

2. Push in the connecting pin.

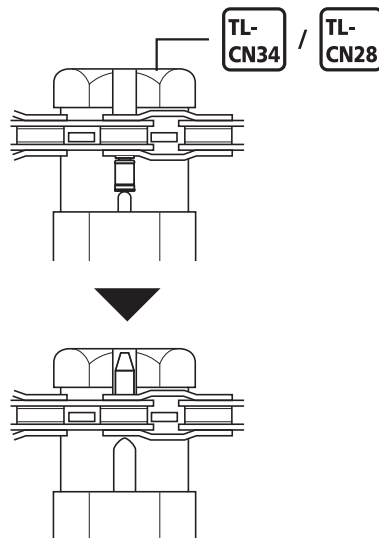

**NOTICE**

- Set the chain on the chain cutter as shown in the figure when using the chain cutter. If the chain cutter is used without properly placing the chain, the positioning plate may be damaged.

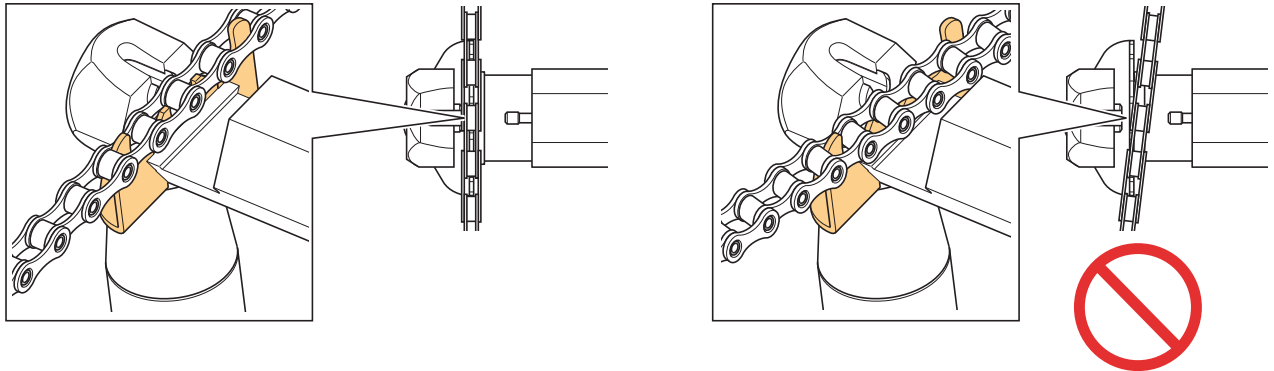

**3. Break off the excess section of the connecting pin.**

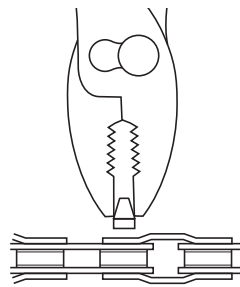

**QUICK-LINK**

**1. Install the QUICK-LINK onto the chain.**

Insert the QUICK-LINK pins between the inner links from both sides as shown in the figure. Place so that the arrow on the surface is pointing in the rotation direction of the crank when viewed from the front.

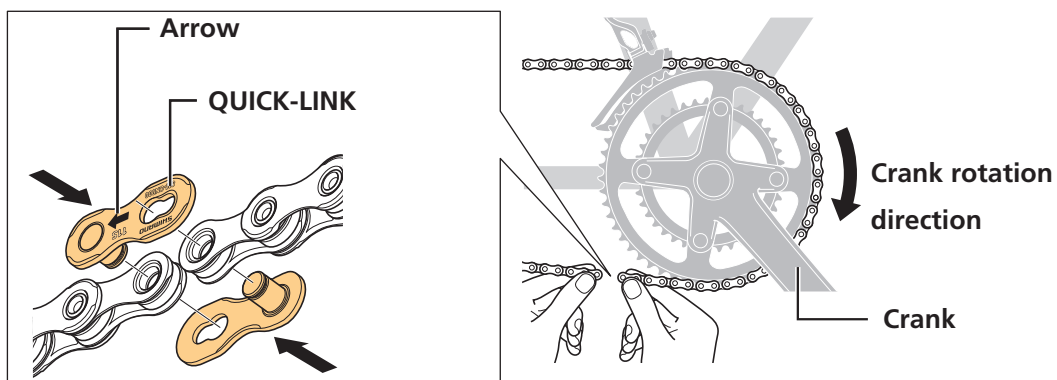

## 2. Secure the QUICK-LINK.

Use SHIMANO original tool TL-CN10 to slide the pins and insert them securely.

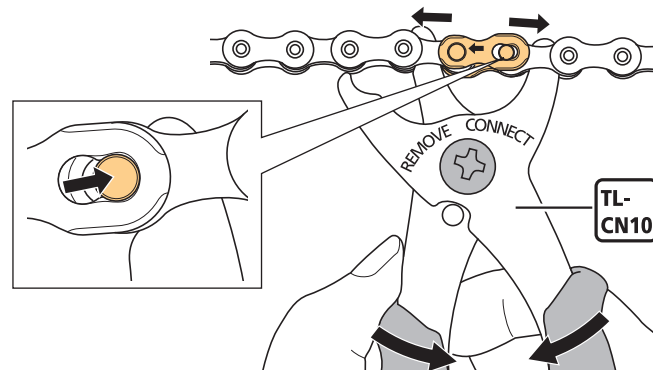

### NOTICE

- Make sure that both sides of the QUICK-LINK are inserted securely as shown in the figure.

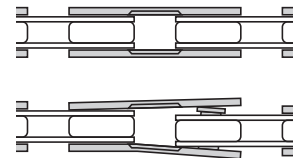

## Removing the QUICK-LINK

### 1. Use SHIMANO original tool TL-CN10 to remove the QUICK-LINK.

Place the tool as shown in the figure, then slide the pins and remove the QUICK-LINK.

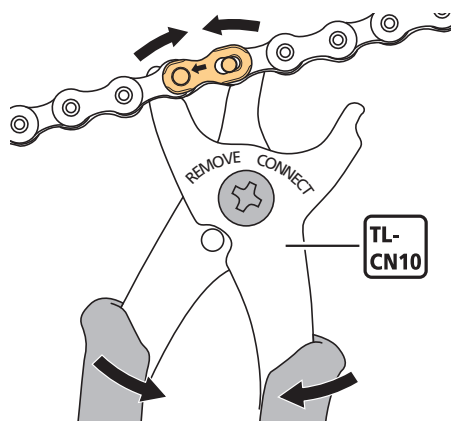

# SHIMANO

**SHIMANO NORTH AMERICA BICYCLE, INC.**

One Holland, Irvine, California 92618, U.S.A. Phone: +1-949-951-5003

**SHIMANO EUROPE B.V.**

High Tech Campus 92, 5656 AG Eindhoven, The Netherlands Phone: +31-402-612222

**SHIMANO INC.**

3-77 Oimatsu-cho, Sakai-ku, Sakai City, Osaka 590-8577, Japan

Please note: specifications are subject to change for improvement without notice. (English)

© Nov. 2020 by SHIMANO INC. ITP