

Dealer's Manual

Chain Device

SM-CD50

IMPORTANT NOTICE

- **This dealer's manual is intended primarily for use by professional bicycle mechanics.**

Users who are not professionally trained for bicycle assembly should not attempt to install the components themselves using the dealer's manuals.

If any part of the information on the manual is unclear to you, do not proceed with the installation. Instead, contact your place of purchase or a local bicycle dealer for their assistance.

- Make sure to read all instruction manuals included with the product.
- Do not disassemble or modify the product other than as stated in the information contained in this dealer's manual.
- All dealer's manuals and instruction manuals can be viewed on-line on our website (<http://si.shimano.com>).
- Please observe the appropriate rules and regulations of the country, state or region in which you conduct your business as a dealer.

For safety, be sure to read this dealer's manual thoroughly before use, and follow it for correct use.

The following instructions must be observed at all times in order to prevent personal injury and physical damage to equipment and surroundings.

The instructions are classified according to the degree of danger or damage which may occur if the product is used incorrectly.

 **DANGER**

Failure to follow the instructions will result in death or serious injury.

 **WARNING**

Failure to follow the instructions could result in death or serious injury.

 **CAUTION**

Failure to follow the instructions could cause personal injury or physical damage to equipment and surroundings.

TO ENSURE SAFETY

WARNING

- **When installing components, be sure to follow the instructions that are given in the instruction manuals.**

It is recommended that you use only genuine Shimano parts. If parts such as bolts and nuts become loose or damaged, the bicycle may suddenly fall over, which may cause serious injury.

In addition, if adjustments are not carried out correctly, problems may occur, and the bicycle may suddenly fall over, which may cause serious injury.

-  Be sure to wear safety glasses or goggles to protect your eyes while performing maintenance tasks such as replacing parts.
- After reading the dealer's manual thoroughly, keep it in a safe place for later reference.

Be sure to also inform users of the following:

- **Downhill bicycle riding and freeriding are inherently dangerous activities. There is a risk of being involved in an accident that can result in a serious injury or even death. It is strongly recommended that riders wear protective head and body gear and perform thorough safety checks of their bicycles before riding. Please remember that you are riding at your own risk and that you have to consider your experience and your skills very carefully.**
- **Check that there are no cracks in the crank arms before riding the bicycle. If there are any cracks, the crank arm may break and you may fall off the bicycle.**
- Be careful not to let the cuffs of your clothes get caught in the chain while riding, otherwise you may fall off the bicycle.

CAUTION

For Installation to the Bicycle, and Maintenance:

- There is the danger of injury from the tips of the teeth on the chainrings.

NOTE

For Installation to the Bicycle, and Maintenance:

- When using the product, do not remove the bushing that is attached on the back of the guard. Otherwise, damage may be caused to the crank arm.
- Use the supplied bolts and nuts for installation. Use of any bolts and nuts other than supplied may cause damage to the bolts, nuts, or crank arm if an impact is given to the guard.
- Use of any guard that is not compatible with the specifications of the front chainwheel may cause damage to the crank arm as the guard cannot absorb the impact. This may also result in incorrect positioning of the guard, causing the chain to come off.
- Replace the skid plate if it is worn. Replace the rubber pad too when replacing the skid plate. If you keep using the worn skid plate, the product will fail to maintain its performance.
- Use a neutral detergent to clean the crank arm and the bottom bracket. Using alkaline or acidic detergents may cause discoloration.
- If pedaling performance does not feel normal, check this once more.
- Do not wash the bottom bracket with high-pressure jets of water. Water may enter the bearing section and cause noise or adhesion.
- You should periodically wash the chainrings in a neutral detergent. In addition, cleaning the chain with neutral detergent and lubricating it can be an effective way of extending the useful life of the chainrings and the chain.
- The cuffs of your clothing may get dirty from the chain while riding.
- This product is not warranted against damage resulting from use such as jumping while riding or if the bicycle falls over, except if such malfunctions result from non conforming materials or manufacturing methods.
- Products are not guaranteed against natural wear and deterioration from normal use and aging.
- For maximum performance we highly recommend Shimano lubricants and maintenance products.

The actual product may differ from the illustration because this manual is intended chiefly to explain the procedures for using the product.

INSTALLATION

■ SM-CD50 Compatible crankset

Spec	Crank set	
With Guard	9 speed	FC-M810 / FC-M815 / FC-M665 / FC-M545
	10 speed	FC-M820 / FC-M825 / FC-M640 / FC-M645
Without Guard (Guide only)	9 speed	Crank with SM-CR81(chainring for single gear)
	10 speed	Crank with SM-CR82(chainring for single gear)

■ List of tools to be used

The following tools are needed to assemble this product.

Where to use	Tool
Lower guide fixing bolt	3 mm Allen key
Upper guide fixing bolt	3 mm Allen key
Back plate fixing bolt	HEXALOBULAR #30
Guard fixing bolt	HEXALOBULAR #30
Guide fin fixing bolt	2.5 mm Allen key
Positioning bolt	4 mm Allen key
Lower guide assembly bolt	HEXALOBULAR #30

■ Installing a guard

1. Choose a compatible guard based on the number of gears.
The number of gears supported is printed on the surface of the guard.
2. Install the guard to the supplied bolt and nut as shown in the illustration.

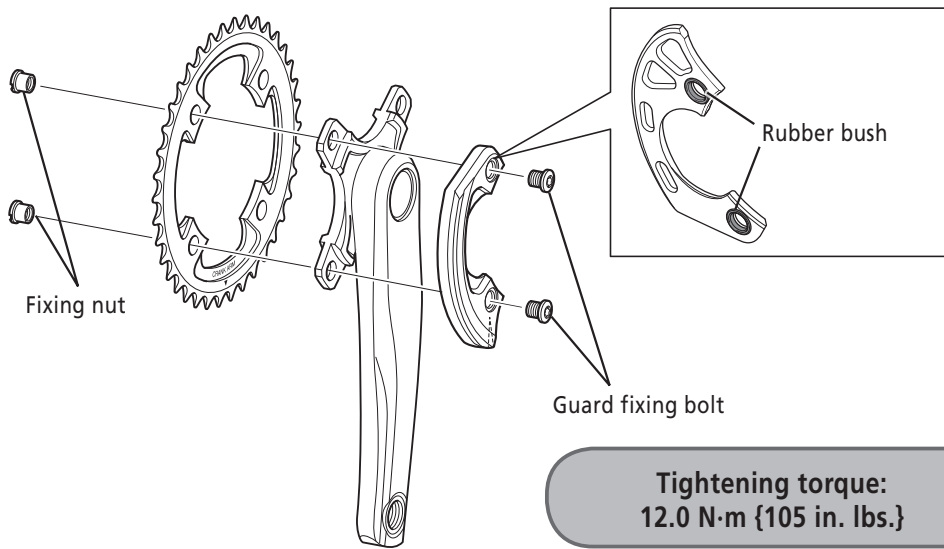

3. Installing the front chainwheel.
For information on how to install the front chainwheel, refer to the dealer's manual for the front chainwheel.

■ Installation to the guides of chain device

1. Attach the positioning bolt to adjust the position of the positioning of the lower guide depending on the number of teeth of the crank to be used.

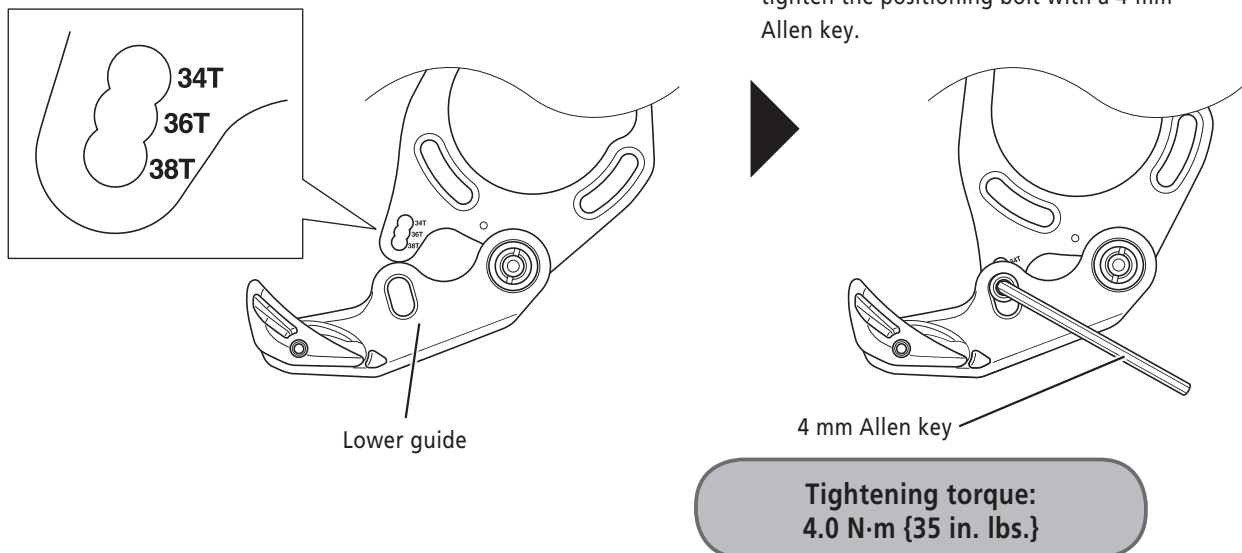

2. Temporarily fix the backplate to the frame.

Note:

To be appropriate for the position of guide skid plate under the crank, putting the spacer depending on BB shell width, chain line of the frame to be used.

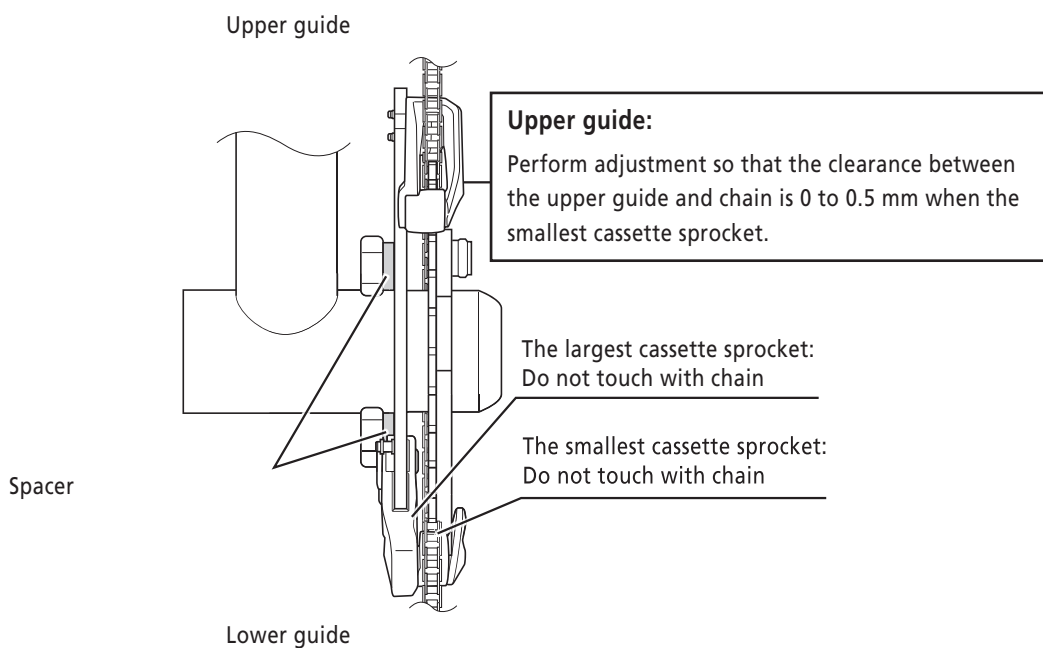
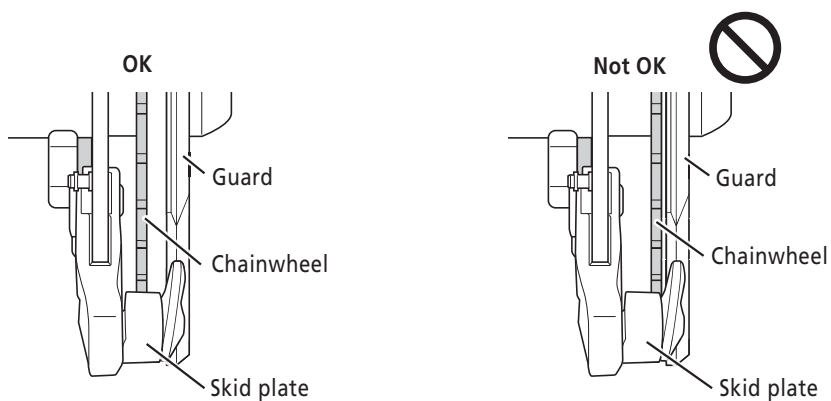
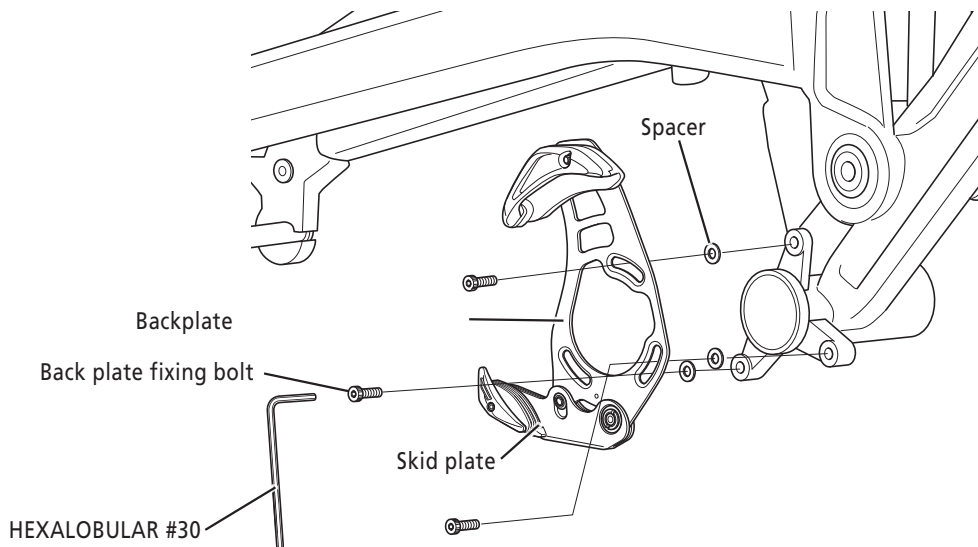

- 3.** Adjust the height of the guide to leave a 0.5 to 1-mm clearance between the upper guide and the narrowest part of the guard, and secure the guide to the backplate.

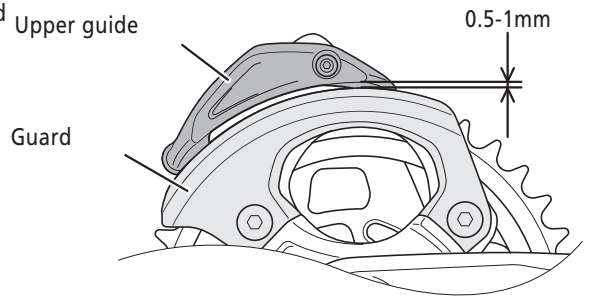

* Adjust the height of the guide to the reading of the backplate scale when not using a guard.

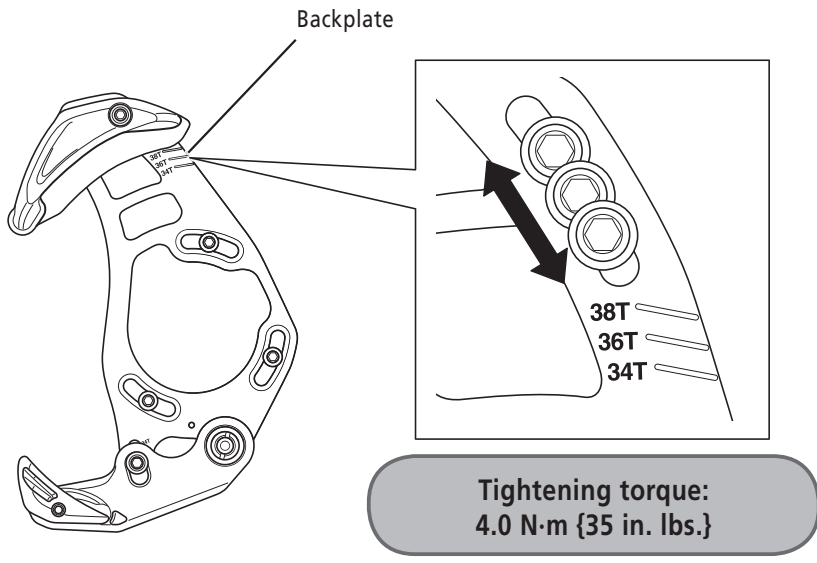

- 4.** After installing the chain, with the cassette sprocket in the lowest position and the rear suspension stretched, rotate the backplate to leave a 0 to 1-mm clearance from the rubber band, and fix the backplate with the clamp bolt.

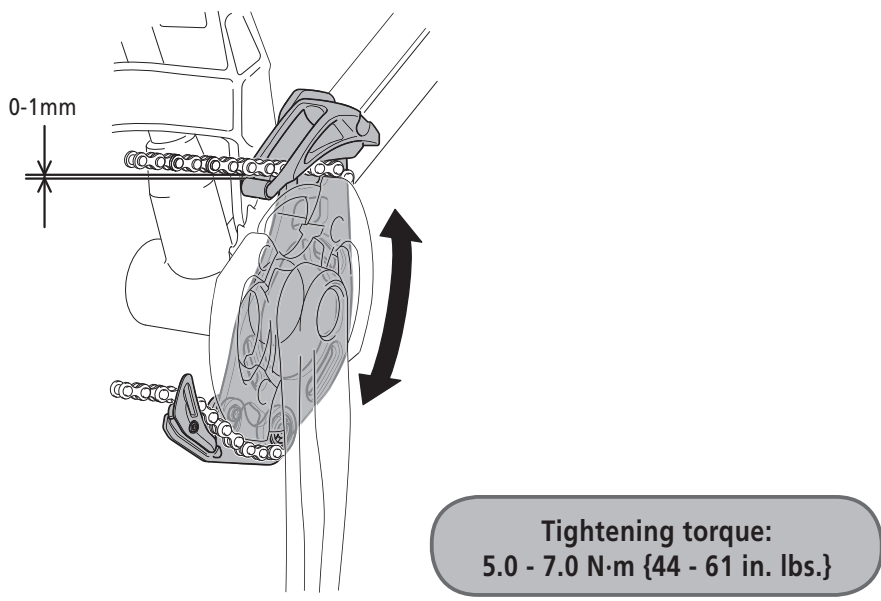

MAINTENANCE

■ Replacing the skid plate

When to replace the skid plate

Replace the skid plate when it is completely worn out (perforated with a hole).

How to replace the skid plate

1. Loosen the guide fin fixing bolt with a 2.5-mm Allen key, and remove the guide fin.

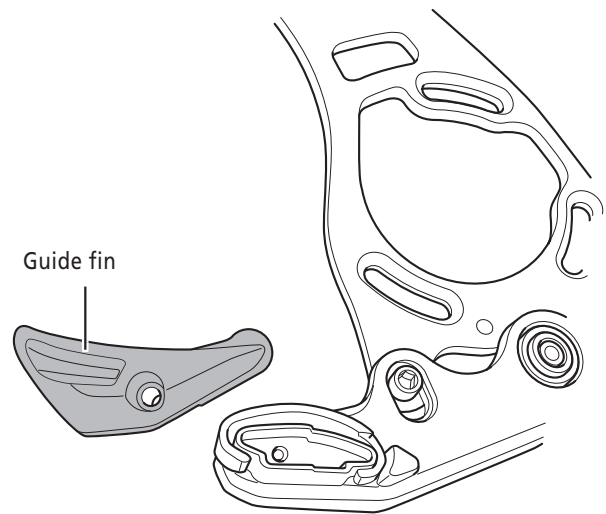
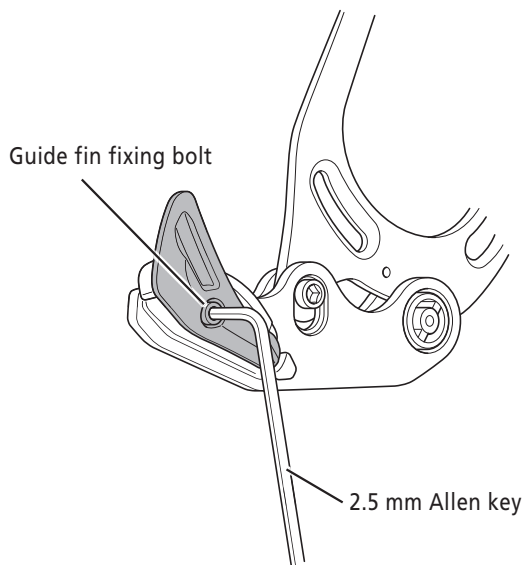

2. Slide and remove the skid plate, and remove the rubber pad.

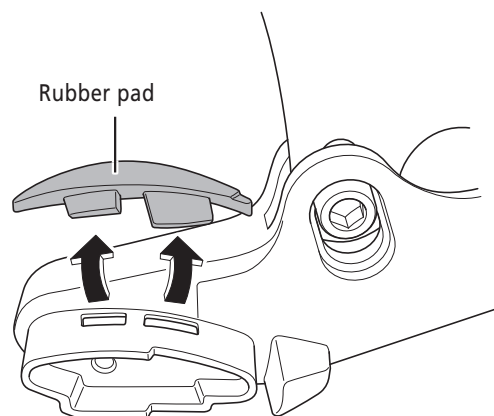
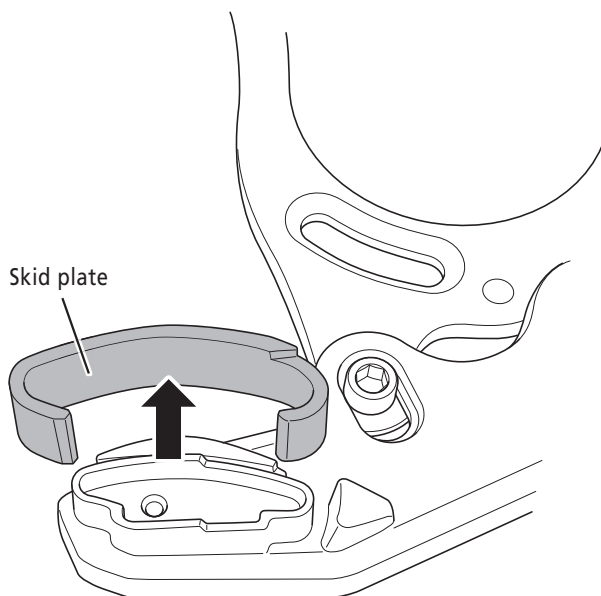

3. When installing a skid plate, reverse the procedure.

Fit the convex part of the rubber pad into the concave part of the lower guide and after attaching the skid plate, tighten the guide fin using 2.5mm allen key.

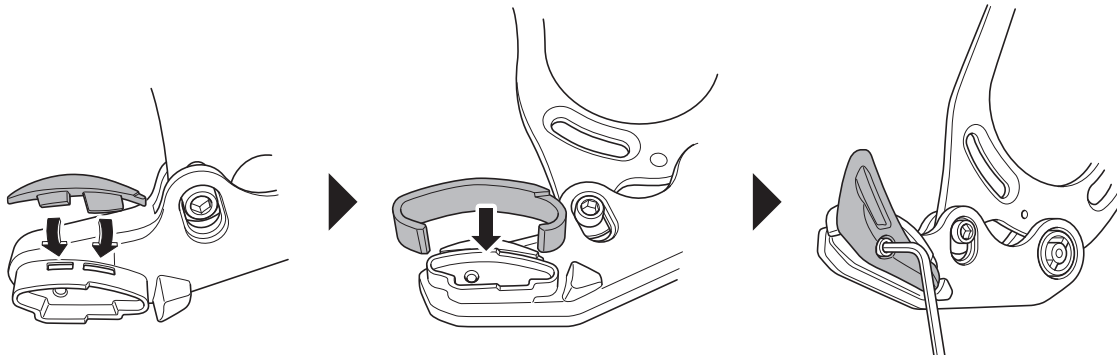

Tightening torque for Guide fin fixing bolt: 0.3 N·m {2.6 in. lbs.}

■ Replacing the lower guide

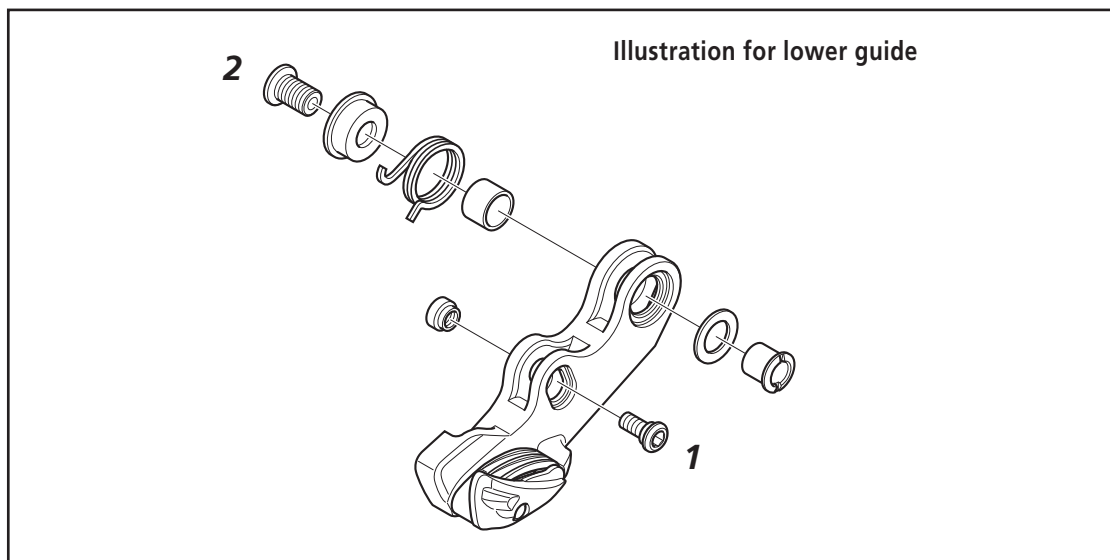

1. Fix the nut with a flat blade screwdriver and loosen the positioning bolt with a 4-mm Allen key. After that, remove the positioning bolt while holding up the lower guide.

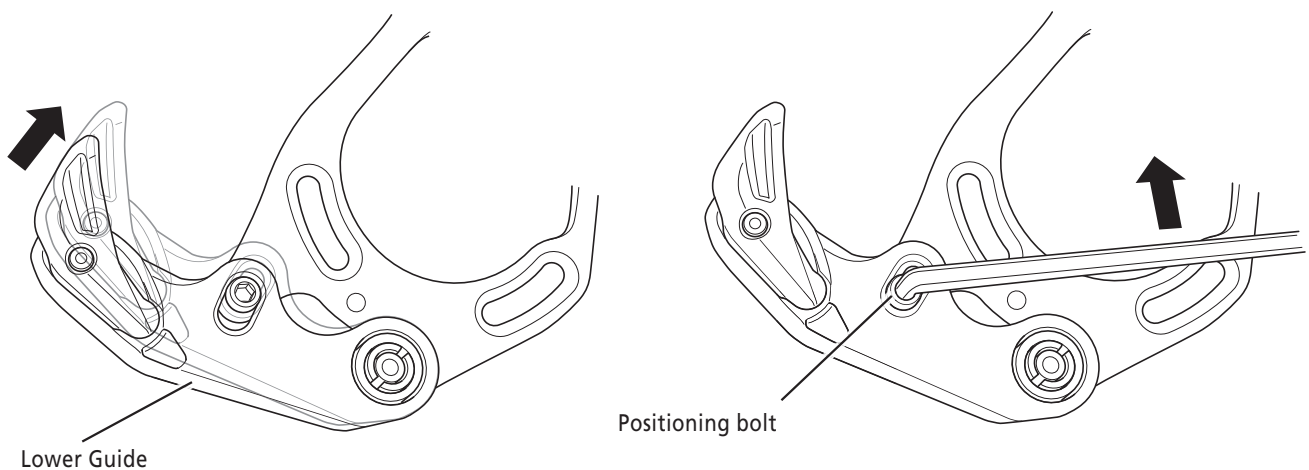

- 2.** Fix the nut with TL-FC20, loosen the lower guide assembly bolt with Hexalobular #30 to remove it, and replace the lower guide with a new one.

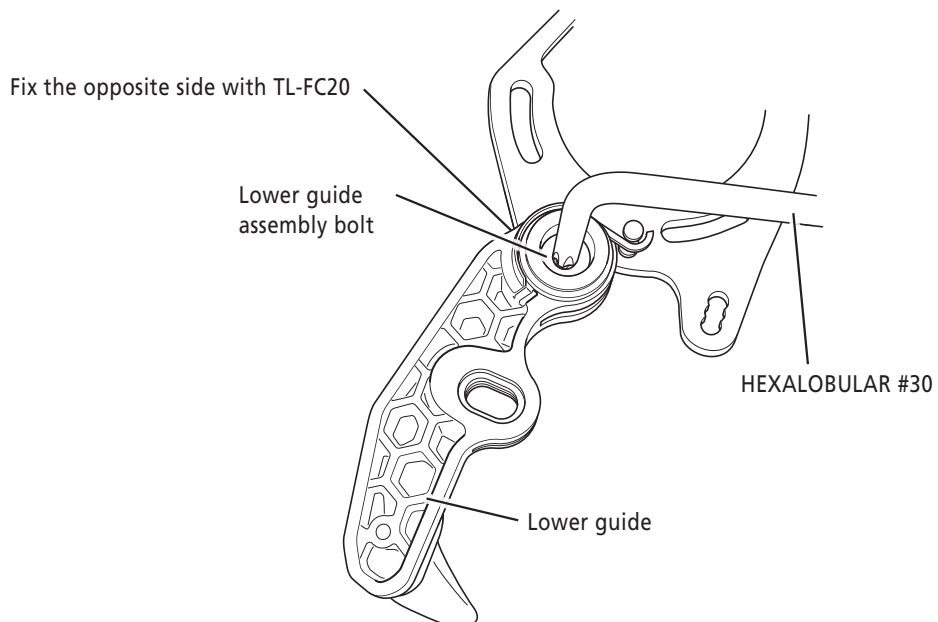

- 3.** When installing a lower guide, reverse the procedure.

Tightening torque:
Lower guide assembly bolt : 2.0 N·m {17 in. lbs.}
Positioning bolt: 4.0 N·m {35 in. lbs.}

■ Replacing the upper guide

1. Remove the positioning bolt.

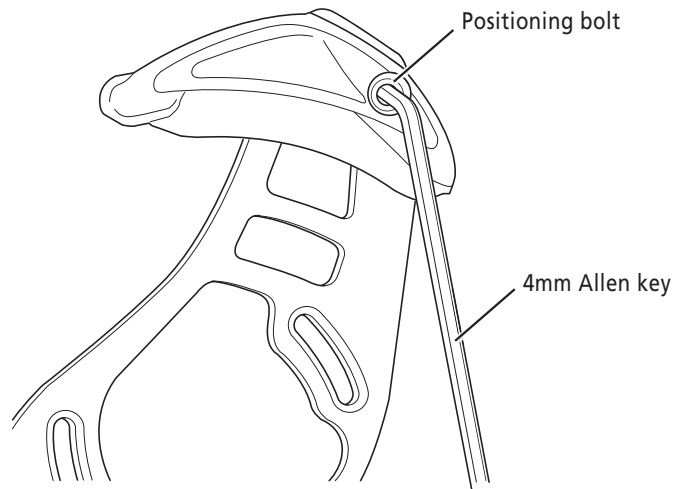

2. Remove the nut from the two lugs and replace the upper guide with a new one.

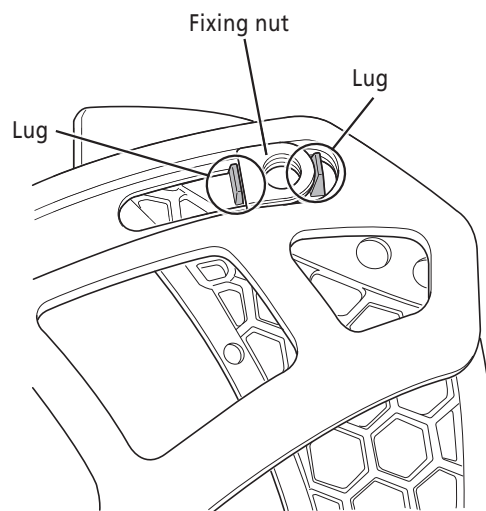

3. When installing an upper guide, reverse the procedure.

Tightening torque:
4.0 N·m {35 in. lbs.}

SHIMANO

SHIMANO AMERICAN CORPORATION

One Holland, Irvine, California 92618, U.S.A. Phone: +1-949-951-5003

SHIMANO EUROPE B.V.

Industrieweg 24, 8071 CT Nunspeet, The Netherlands Phone: +31-341-272222

SHIMANO INC.

3-77 Oimatsu-cho, Sakai-ku, Sakai-shi, Osaka 590-8577, Japan

Please note: specifications are subject to change for improvement without notice. (English)