

# Dealer's Manual

ROAD	MTB	Trekking
City Touring/ Comfort Bike	URBAN SPORT	E-BIKE

## Hydraulic Disc Brake

### XTR

BR-M9000  
BR-M9020  
BR-M987

BL-M9000  
BL-M9020  
BL-M988-B  
BL-M987

### SAINT

BR-M820  
BL-M820  
BL-M820-B

### DEORE XT

BR-M8000  
BR-M8020  
BR-M785  
BL-M8000  
BL-M785-B

### SLX

BR-M675  
BL-M675  
BL-M675-B

### ZEE

BR-M640  
BL-M640  
BL-M640-B

### DEORE

BR-M615  
BL-M615

### ALIVIO

BR-M4050

### ACERA

BR-M3050

### SHIMANO

BR-M447  
BR-M395  
BL-M506  
BL-M425  
BL-M396  
BL-M395  
BR-MT520  
BL-MT501

### DEORE XT (Trekking)

BL-T785-B

### DEORE LX (Trekking)

BR-T675  
BL-T675  
BL-T675-B

### DEORE (Trekking)

BR-T615  
BL-T615

### Mount adapter

SM-MA-F180P/P2  
SM-MA90-F180P/P  
SM-MA-F203P/PM  
SM-MA90-F203P/PM

# CONTENTS

<b>IMPORTANT NOTICE .....</b>	<b>3</b>
<b>TO ENSURE SAFETY.....</b>	<b>4</b>
<b>LIST OF TOOLS TO BE USED.....</b>	<b>9</b>
<b>INSTALLATION.....</b>	<b>11</b>
Disc brake mount adapter (for 180/203 mm disc brake rotors) .....	11
Disc brake rotor adapter.....	13
Brake hose .....	16
<b>MAINTENANCE .....</b>	<b>19</b>
Adding SHIMANO genuine mineral oil and bleeding air .....	19
Replacing the brake hose .....	25
Replacing the brake pads .....	31
Designated parts for magnesium products .....	33

## IMPORTANT NOTICE

- **This dealer's manual is intended primarily for use by professional bicycle mechanics.**

Users who are not professionally trained for bicycle assembly should not attempt to install the components themselves using the dealer's manuals. If any part of the information on the manual is unclear to you, do not proceed with the installation. Instead, contact your place of purchase or a local bicycle dealer for their assistance.

- Make sure to read all instruction manuals included with the product.
- Do not disassemble or modify the product other than as stated in the information contained in this dealer's manual.
- All manuals and technical documents are accessible online at <https://si.shimano.com>.
- For consumers who do not have easy access to the internet, please contact a SHIMANO distributor or any of the SHIMANO offices to obtain a hardcopy of the User's Manual.
- Please observe the appropriate rules and regulations of the country, state or region in which you conduct your business as a dealer.

**For safety, be sure to read this dealer's manual thoroughly before use, and follow it for correct use.**

The following instructions must be observed at all times in order to prevent personal injury and physical damage to equipment and surroundings. The instructions are classified according to the degree of danger or damage which may occur if the product is used incorrectly.

 **DANGER**

Failure to follow the instructions will result in death or serious injury.

 **WARNING**

Failure to follow the instructions could result in death or serious injury.

 **CAUTION**

Failure to follow the instructions could cause personal injury or physical damage to equipment and surroundings.

## TO ENSURE SAFETY

### WARNING

- **Be sure to follow the instructions provided in the manuals when installing the product.**

It is recommended that you use SHIMANO genuine parts. If parts such as screws and nuts become loose or damaged, the bicycle may suddenly fall over, which may cause serious injury.

-  Wear approved eye protection while performing maintenance tasks such as replacing components.

### Be sure to also inform users of the following:

#### SAINT/ZEE

- **Downhill bicycle riding and freeriding are inherently dangerous activities. There is a risk of being involved in an accident that can result in a serious injury or even death. It is strongly recommended that riders wear protective head and body gear and perform thorough safety checks of their bicycles before riding. Please remember that you are riding at your own risk and that you have to consider your experience and your skills very carefully.**

- Riders must become accustomed to the higher performance of this brake in a controlled environment before riding the bicycle as described above.

The brake system is designed for downhill bicycle riding and freeriding, and its braking performance is much higher than for other brakes. If you do not familiarize yourself with the performance level of this brake, you may be involved in an accident that could result in serious injury or even death. Furthermore, the settings of the brakes makes them unsuitable for riding on city streets. If riding the bicycle on streets is unavoidable, take extreme care while doing so.

- Because each bicycle may handle slightly differently depending on the model, be sure to learn the proper braking technique (including brake lever pressure and bicycle control characteristics) and operation of your bicycle. Improper use of your bicycle's brake system may result in a loss of control or a fall, which could lead to severe injury.
- Make sure that you completely understand the braking characteristics before using the brakes. The 203 mm and 180 mm disc brake rotors provide a higher braking force than the 160 mm disc brake rotors. If you ride the bicycle without sufficiently familiarizing yourself with the characteristics of this brake, brake operations may cause a fall and result in an accident that could lead to serious injury or even death.
- Please use extra caution to keep your fingers away from the rotating disc brake rotor. The disc brake rotor is sharp enough to inflict severe injury to your fingers if caught within the openings of moving rotor.



- Do not touch the calipers and disc brake rotor while riding or immediately after dismounting from the bicycle. The calipers and disc brake rotor will become hot when the brakes are operated, so you may get burned if you touch them.
- Be careful not to allow any oil or grease to get onto the disc brake rotor and brake pads. Riding the bicycle with oil or grease on the disc brake rotor and brake pads may prevent the brakes from operating and result in serious injury due to a fall or collision.
- Check the thickness of the brake pads and do not use them if they have a thickness of 0.5 mm or less. Doing so may prevent the brakes from operating and result in serious injury.

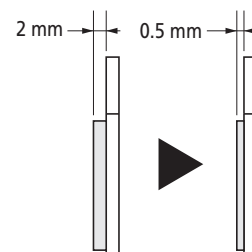

- Do not use the disc brake rotor if it is cracked or deformed. The disc brake rotor may break, and result in serious injury due to a fall.
- Do not use the disc brake rotor if its thickness is 1.5 mm or less. Also do not use it if the aluminum surface becomes visible. The disc brake rotor may break, and result in serious injury due to a fall.
- Do not continuously apply the brakes. Doing so may cause a sudden increase in the brake lever stroke and prevent the brakes from operating and result in serious injury.
- Do not use the brakes with fluid leaking. Doing so may prevent the brakes from operating and result in serious injury.
- Do not apply the front brake too strongly. If you do so, the front wheel may lock and the bicycle may fall forward, and serious injury may result.

**TO ENSURE SAFETY**

- Because the required braking distance will be longer during wet weather, reduce your speed and apply the brakes early and gently. You may fall or collide and be seriously injured.
- A wet road surface may cause tires to skid; therefore, to avoid this, reduce your speed and apply the brakes early and gently. If the tires skid, you may fall and be seriously injured.

**For Installation to the Bicycle, and Maintenance:**

- Please make sure to keep your fingers away from the rotating disc brake rotor during installation or maintenance of the wheel. The disc brake rotor is sharp enough to inflict severe injury to your fingers if caught within the openings of moving rotor.



- Do not use the disc brake rotor if it is cracked or warped. The disc brake rotor may break, and result in serious injury due to a fall.
- Do not use the disc brake rotor if its thickness is 1.5 mm or less. Also do not use it if the aluminum surface becomes visible. The disc brake rotor may break, and result in serious injury due to a fall.
- The calipers and disc brake rotor will become hot when the brakes are operated; do not touch them while riding or immediately after dismounting from the bicycle. Otherwise, you may get burned.
- Be careful not to allow any oil or grease to get onto the disc brake rotor and brake pads. Riding the bicycle in that state may prevent the brakes from operating and result in serious injury due to a fall or collision.
- Check the thickness of the brake pads and do not use them if they have a thickness of 0.5 mm or less. Doing so may prevent the brakes from operating and result in serious injury.
- Do not use oil other than SHIMANO genuine mineral oil. Doing so may prevent the brakes from operating and result in serious injury.
- Be sure to use only oil from a freshly-opened container. Doing so may prevent the brakes from operating and result in serious injury.
- Do not let water or air bubbles to get into the brake system. Doing so may prevent the brakes from operating and result in serious injury.
- Do not use with a tandem bicycle. Doing so may prevent the brakes from operating and result in serious injury due to a fall or collision.

**■ SM-RTAD05 Disc brake rotor adapter**

- Do not install disc brake rotors with a diameter greater than 203 mm. Otherwise, the resulting braking forces may damage the brake.

**■ Brake hose**

- Refer to the table below, and do not use an incorrect connector insert. Doing so may prevent the brakes from operating and result in serious injury.

Brake hose	Connector insert	
	Length	Color
SM-BH90	11.2 mm	Silver
SM-BH59/80	13.2 mm	Gold
YM-BH81	13.2 mm	Silver

- Do not reuse the olive piece or the connector insert when reinstalling. Doing so may prevent the brakes from operating and result in serious injury due to a fall.

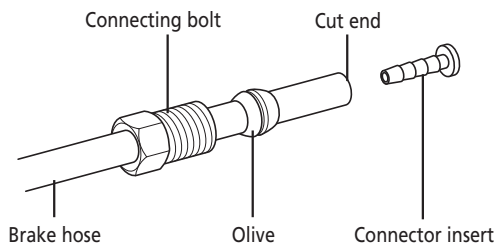

- Cut the brake hose so that the cut end is perpendicular to the length of the hose. If the brake hose is cut at an angle, fluid leaks may result.



**Be sure to also inform users of the following:****■ Cautions on SHIMANO genuine mineral oil**

- In the event of eye contact, flush with fresh water and seek medical assistance immediately. Contact with eyes may result in irritation.
- In the event of skin contact, wash well with soap and water. Contact with eyes may result in irritation.
- Cover nose and mouth with a respirator type mask and use in a well ventilated area. Inhalation of mineral oil mist or vapors may cause nausea. If mineral oil mist or vapor is inhaled, go immediately to an area with fresh air. Cover up with a blanket. Stay warm and stable and seek professional medical advice.

**■ Burn-in period**

- Disc brakes have a burn-in period, and the braking force will gradually increase as the burn-in period progresses. Make sure that you are aware of any such increases in braking force when using the brakes during the burn-in period. The same thing will happen when the brake pads or disc brake rotor are replaced.

**For installation to the bicycle, and maintenance:**

- When using the SHIMANO original tool (TL-FC36) to remove and install the disc brake rotor lock ring, wear gloves and be careful not to touch the outer edges of the disc brake rotor with your hands. Failure to do so may result in cuts to your hands.

**■ Handling SHIMANO genuine mineral oil**

- Use safety glasses when handling, and avoid contact with eyes. In the event of eye contact, flush with fresh water and seek medical assistance immediately. Contact with eyes may result in irritation.
- Use gloves when handling. In the event of skin contact, wash well with soap and water. Contact with eyes may result in irritation.
- Do not drink. May cause vomiting or diarrhea.
- Keep out of reach of children.
- Do not cut, let near heat, weld or pressurize the SHIMANO genuine mineral oil container. Doing so may cause an explosion or fire.
- Disposal of Used Oil: Follow local county and/or state codes for disposal. Use caution when preparing the oil for disposal.
- Directions: Keep the container sealed to prevent foreign objects and moisture from getting inside, and store it in a cool, dark area away from direct sunlight or heat. Keep from heat or flame, Petroleum Class III, Danger level III

**■ Brake hose**

- When cutting the brake hose, handle the knife carefully so as not to cause injury.
- Be careful to avoid injury from the olive.

## NOTICE

**Be sure to also inform users of the following:**

- When the bicycle wheel has been removed, it is recommended that pad spacers are installed. Do not depress the brake lever while the wheel is removed. If the brake lever is depressed without the pad spacers installed, the pistons will protrude further than normal. If that happens, consult a dealer.
- Use soapy water and a dry cloth when cleaning and carrying out maintenance of the brake system. Do not use commercially available brake cleaners or silencing agents. Such substances can cause damage to parts such as seals.
- In the case of carbon levers, wash them with a soft cloth using a neutral detergent. Otherwise, the material may break down and be damaged.
- Avoid leaving the carbon levers in areas of high temperature. Also keep them well away from fire.
- Products are not guaranteed against natural wear and deterioration from normal use and aging.
- For maximum performance we highly recommend SHIMANO lubricants and maintenance products.

**■ SAINT/ZEE**

- This product is not warranted against damage resulting from improper use, such as jumping while riding or if the bicycle falls over, except if such malfunctions are caused by manufacturing methods.

**For Installation to the Bicycle, and Maintenance:**

- The 203 mm and 180 mm disc brake rotors have a larger diameter than the 160 mm disc brake rotor for cross-country bicycles, and so the flexing of these disc brake rotors is greater. As a result, they will interfere with the brake pads.
- If the brake caliper mounting boss and the dropout are not parallel, the disc brake rotor and caliper may touch.
- When the bicycle wheel has been removed, it is recommended that pad spacers are installed. The pad spacers will prevent the piston from coming out if the brake lever is depressed while the wheel is removed.
- If the brake lever is depressed without the pad spacers installed, the pistons will protrude further than is normal. Use a flat-shaped tool to push back the brake pads, while being careful not to damage the surfaces of the brake pads.  
(If the brake pads are not installed, use a flat-shaped tool to push the pistons straight back in, while being careful not to damage them.)  
If it is difficult to push the brake pads or pistons back, remove the bleed screws and then try again. (Note that some oil may overflow from the reservoir tank at this time.)
- Use isopropyl alcohol, soapy water or a dry cloth when cleaning and carrying out maintenance of the brake system. Do not use commercially available brake cleaners or silencing agents. Such substances can cause damage to parts such as seals.
- Do not remove the pistons when disassembling the calipers.
- If the disc brake rotor is worn, cracked or warped, it should be replaced.
- The caliper of BR-M9000/BR-M987 and the master cylinder of BL-M9000/BL-M987 are made of magnesium. Corrosion starts when these components come into contact with parts made of other types of metals, such as iron bolts. In the contact area, water residue, sweat, rain and other moisture particles may create a potential reaction. This forms an electrochemical cell, resulting in an electrochemical reaction. To prevent this problem, each part is treated with a special-purpose surface treatment. Use appropriate parts to prevent the progression of rusting. For more details, refer to "Designated parts for magnesium products" in "MAINTENANCE".

**■ SM-RTAD05 Disc brake rotor adapter**











- When using this disc brake rotor adapter to install disc brake rotors, the structure of the adapter means that there will be more play than normal in the disc brake rotor. Because of this, the disc brake rotor may interfere with the brake pads. Furthermore, it may also interfere with the calipers in the radial direction (upward).
- This product cannot be used with the 6-bolt disc brake rotor that is installed with an aluminum adapter (SM-RT86/RT76).

The actual product may differ from the illustration because this manual is intended mainly to explain the procedures for using the product.

# **LIST OF TOOLS TO BE USED**

## LIST OF TOOLS TO BE USED

The following tools are needed for installation, adjustment, and maintenance purposes.

Tool		Tool		Tool	
	2 mm hexagon wrench		8 mm spanner		TL-BH61
	3 mm hexagon wrench		Utility knife		TL-FC36
	4 mm hexagon wrench		Slotted screwdriver		Micrometer
	5 mm hexagon wrench		Hexalobular[#15]		

# INSTALLATION

▶▶ Disc brake mount adapter (for 180/203 mm disc brake rotors)

# INSTALLATION

- \* Refer to the Disc Brake section of General Operations for how to install the brake caliper, brake lever, and disc brake rotor.
- \* SM-MA-F203-P/PM and SM-MA90-F203-P/PM are adapters that allow 203 mm disc brake rotors to be used on frames designed for 180 mm disc brake rotors.

## ■ Disc brake mount adapter (for 180/203 mm disc brake rotors)

SM-MA-F180P/P2 SM-MA90-F180P/P (for 180 mm disc brake rotors)  
 SM-MA-F203-P/PM SM-MA90-F203-P/PM (for 203 mm disc brake rotors)

Place the adapter onto the brake caliper, and then install the adapter to the frame.



**1**

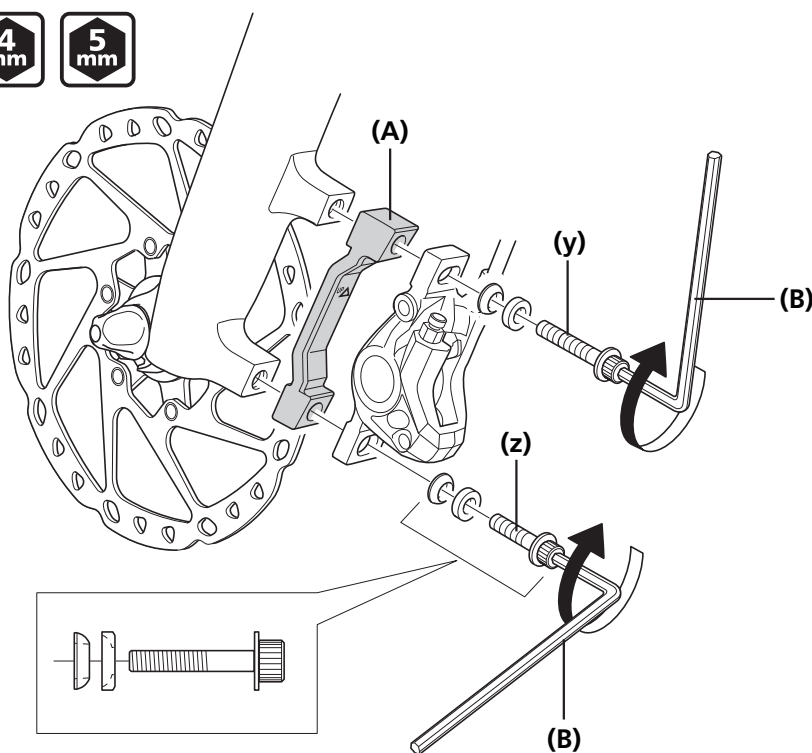

**(y)** Long

**(z)** Short

**(A)** Mount adapter

**(B)** 5 mm hexagon wrench /  
4 mm hexagon wrench

**Tightening torque**



**6 - 8 N·m**



**INSTALLATION**

▶▶ Disc brake mount adapter (for 180/203 mm disc brake rotors)

Secure the caliper fixing bolt.

**2**

<Cap method>

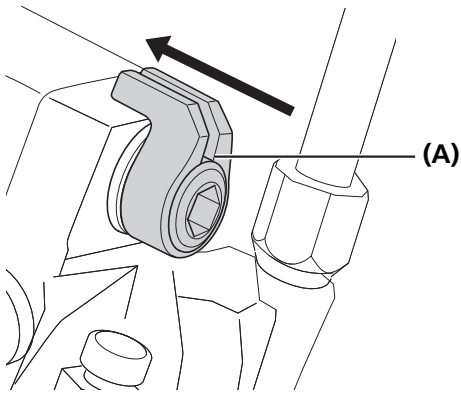

<Wiring method>

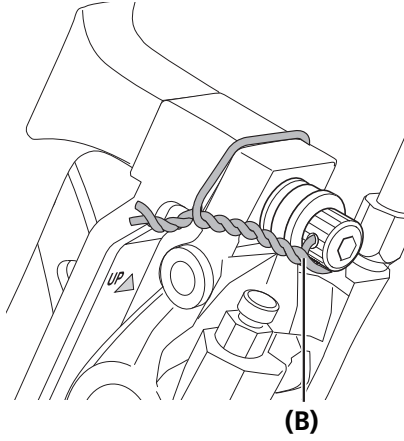

**(A)** Cap

**(B)** Wire

■ Disc brake rotor adapter

SM-RTAD05

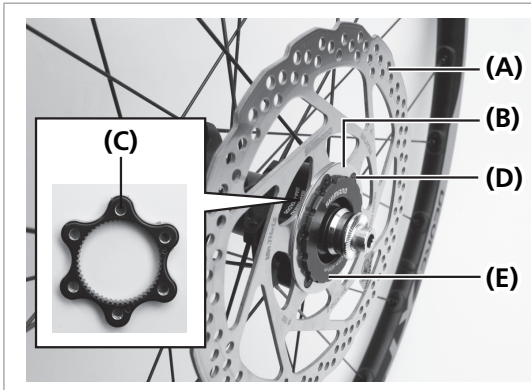

This product is an adapter used for installing 6 bolt type disc brake rotors to center lock system hubs/wheels.

- (A) Disc brake rotor
- (B) Washer
- (C) Disc brake rotor adapter
- (D) Disc brake rotor fixing bolt
- (E) Disc brake rotor lock ring

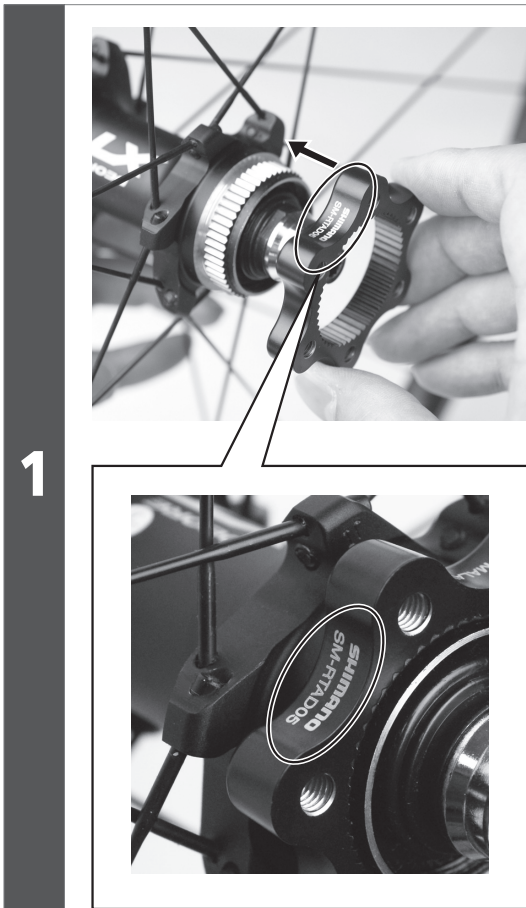

Place the disc brake rotor adapter on to the hub.

1

**INSTALLATION**

▶▶ Disc brake rotor adapter

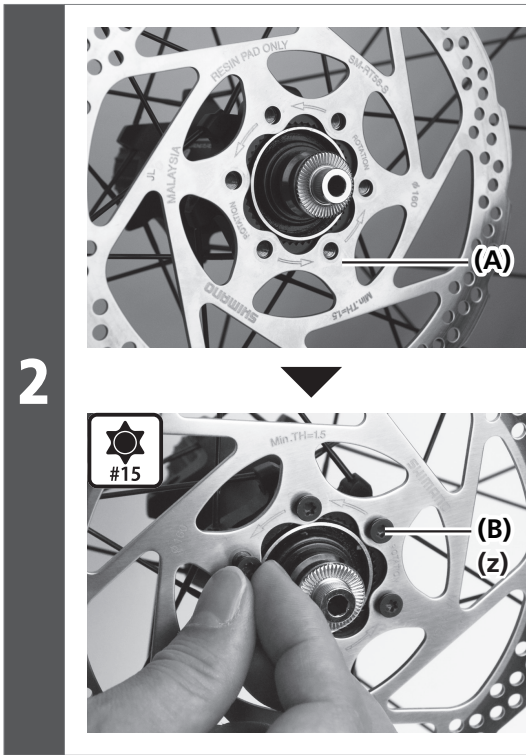

Place the disc brake rotor on to the hub, and then temporarily fix it in place by tightening the disc brake rotor fixing bolts.

(z) Hexalobular[#15]

(A) Disc brake rotor

(B) Disc brake rotor fixing bolt

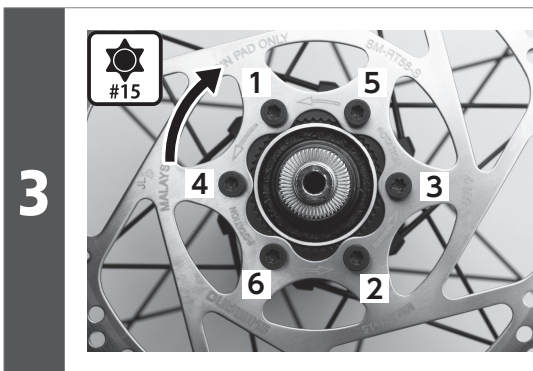

Wear gloves and turn the disc brake rotor clockwise with some force.

Then, tighten the disc brake rotor fixing bolts in the order shown in the illustration.

Tightening torque



2 - 4 N·m

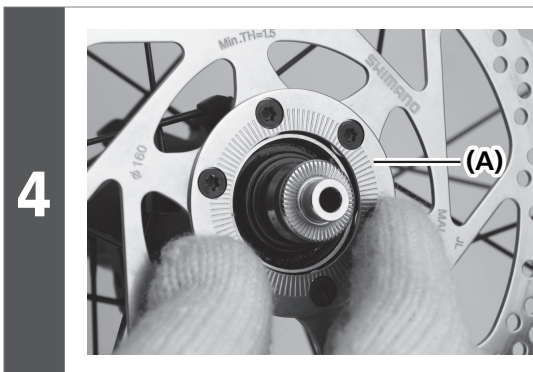

Fit the washer.

(A) Washer

## INSTALLATION

### ▶▶ Disc brake rotor adapter

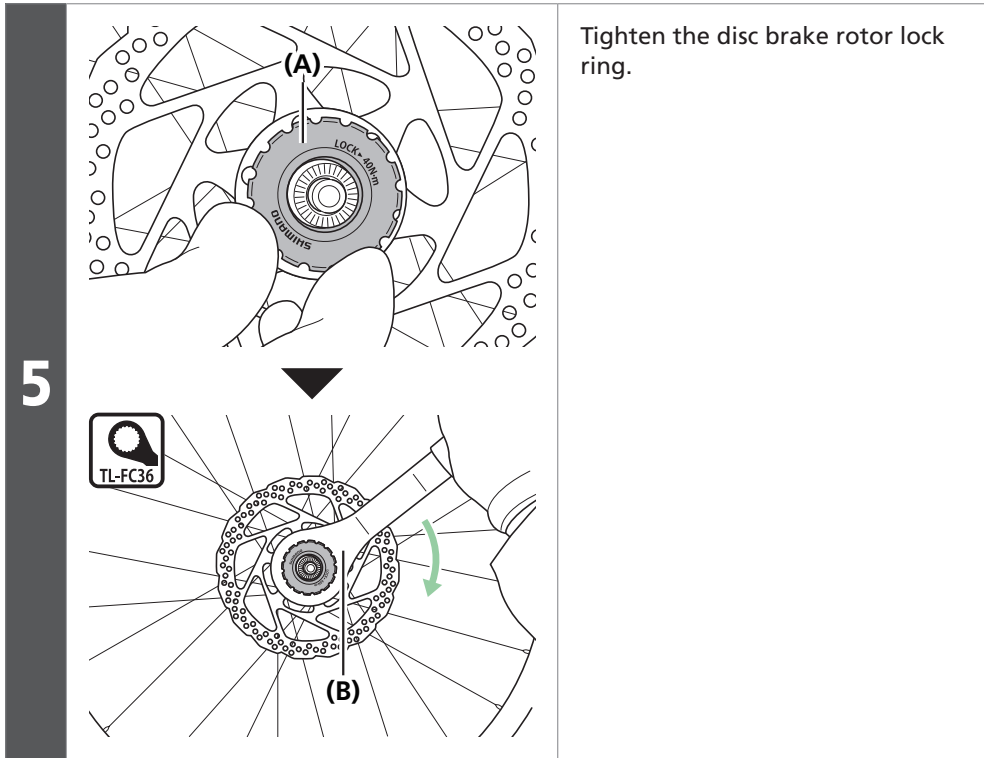

Tighten the disc brake rotor lock ring.

(A) Disc brake rotor lock ring

(B) TL-FC36

#### Tightening torque



TL-FC36

40 N·m

**■ Brake hose**

For information on installing the brake hose, refer to the brake section of General Operations.

Make sure that the calipers and levers are in the positions shown in the illustrations.

**XTR/DEORE XT (BR-M8000/BR-M785)**

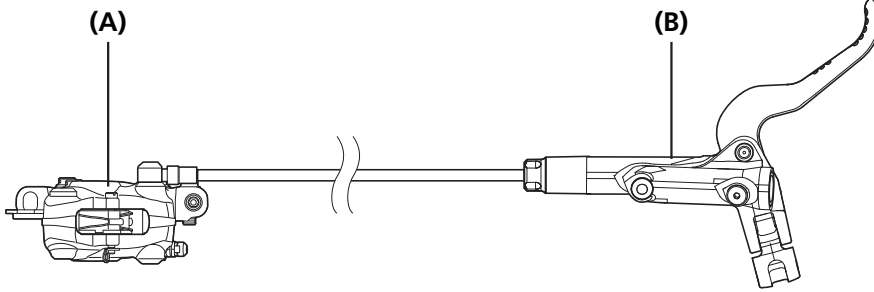

**SAINT/ZEE/DEORE XT (BR-M8020)**

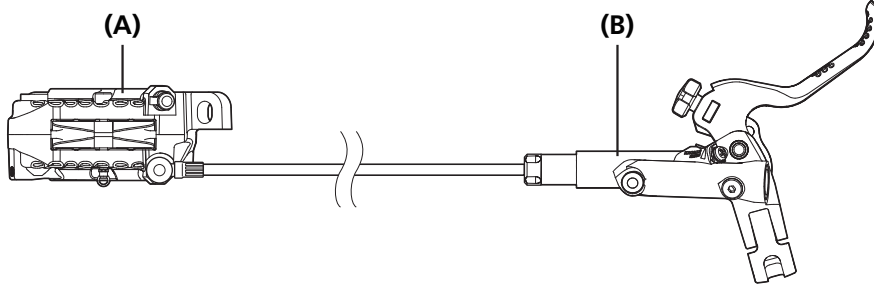

**SLX**

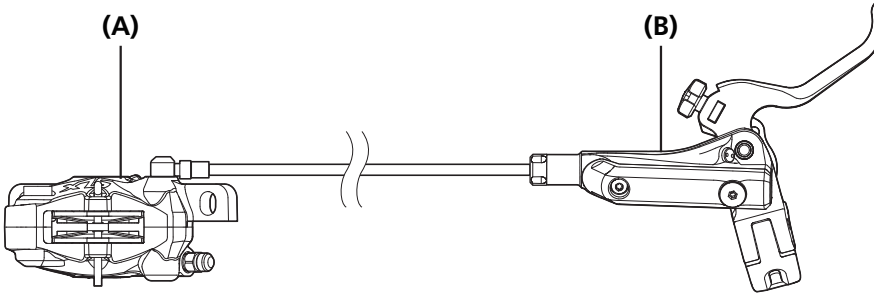

**DEORE LX (Trekking)/DEORE (Trekking)/M395/M447/M4050/M3050**

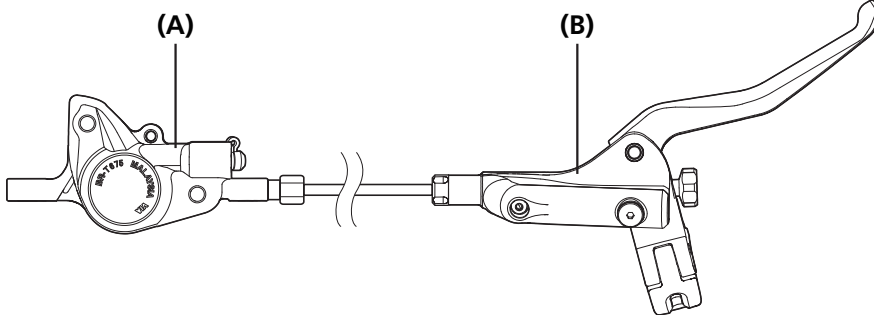

**BR-MT520**

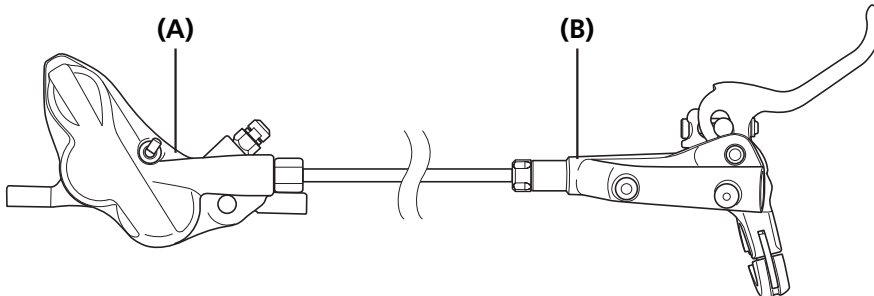

**(A)** Brake caliper

**(B)** Brake lever

**NOTICE**

- The installation position of the brake hose differs depending on the model.
- Do not let the brake hose become twisted when installing it.

## Overview of the easy hose joint system

For information on how to install and replace the brake hose, refer to the brake section of General Operations.

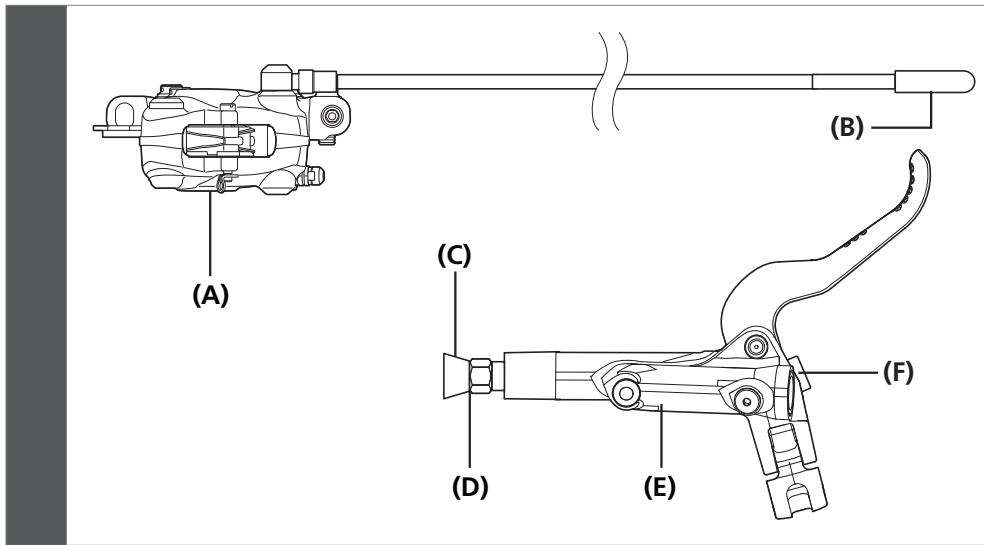

- (A)** Brake caliper
- (B)** Hose cap
- (C)** Seal plug
- (D)** Hose connection port
- (E)** Brake lever
- (F)** Stopper

# MAINTENANCE

# MAINTENANCE

This section describes specification differences between products that are not included in the disc brake section of General Operations.

## ■ Adding SHIMANO genuine mineral oil and bleeding air

BR-M447/BR-M4050/BR-M395/BR-M3050

When removing air from the brake caliper, a funnel is needed.



### SHIMANO genuine mineral oil replacement

It is recommended to replace the oil inside the reservoir tank if it becomes severely discolored.

Attach a tube with a bag to the bleed nipple, and then open the bleed nipple to drain out the oil. The brake lever can be operated at this time to help the oil drain out. After this, add oil while referring to the section "Adding SHIMANO genuine mineral oil and bleeding air".

Use only SHIMANO genuine mineral oil.

Dispose of the waste oil according to proper country and/or state disposal regulations.

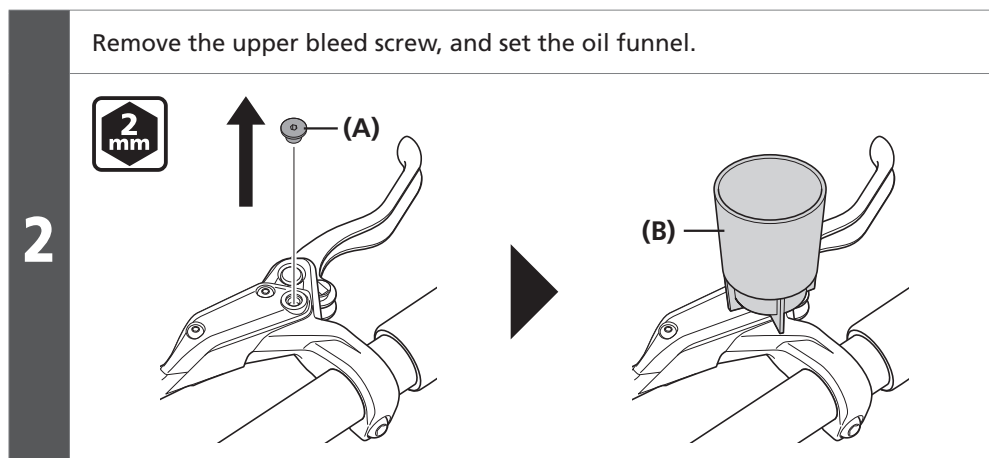
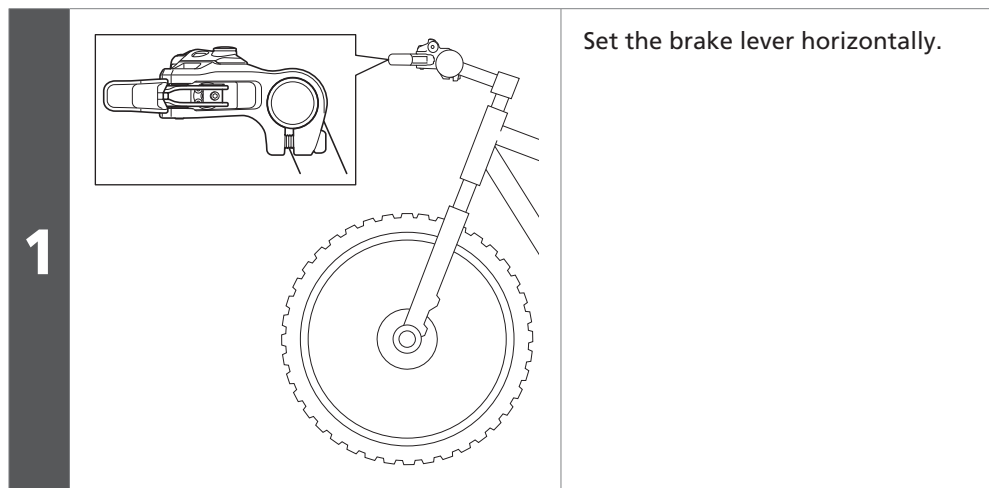

▶▶ Adding SHIMANO genuine mineral oil and bleeding air

**3**

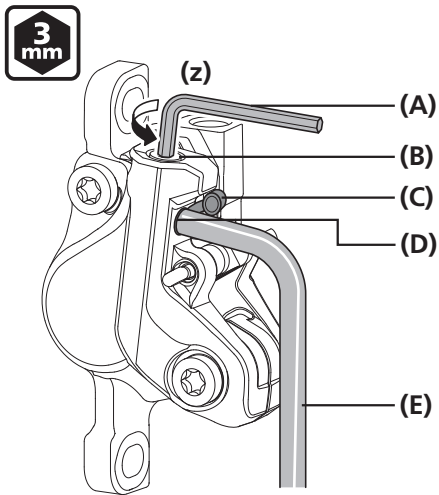

Remove the bleed nipple cap of the caliper, fill the syringe with oil, and connect the tube to the bleed nipple.

Use a 3 mm hexagon wrench to loosen the bleed screw by 1/8th of a turn to open it.

When the plunger of the syringe is pushed to add oil, oil will start coming out through the oil funnel.

Continue adding oil until there are no more air bubbles mixed in with the oil that is coming out.

**(z)** 1/8th of a turn

- (A)** 3 mm hexagon wrench
- (B)** Bleed screw
- (C)** Bleed nipple cap
- (D)** Bleed nipple
- (E)** Brake hose from syringe

**NOTICE**

Secure the brake caliper in a vise to prevent the tube from being accidentally disconnected.

Do not depress and release the lever repeatedly.

Oil without air bubbles may come out as a result of such operation, but air bubbles may remain in the oil inside the brake caliper, and it will take longer to bleed the air. (If you have depressed and released the lever repeatedly, drain out all of the oil and then add oil again.)

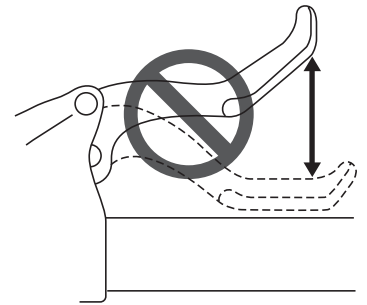

**4**

Once there are no more air bubbles mixed in with the oil, temporarily close the bleed nipple.

Remove the syringe while covering the end of the syringe tube with a clean rag to prevent oil from spattering.

▶▶ Adding SHIMANO genuine mineral oil and bleeding air

**5**

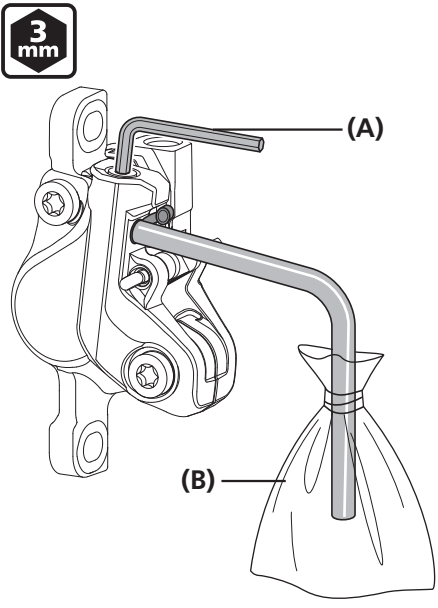

Secure the tube and bag with rubber bands, set a 3 mm hexagon wrench as shown in the illustration, and connect the tube to the bleed nipple.

- (A) 3 mm hexagon wrench
- (B) Bag

**6**

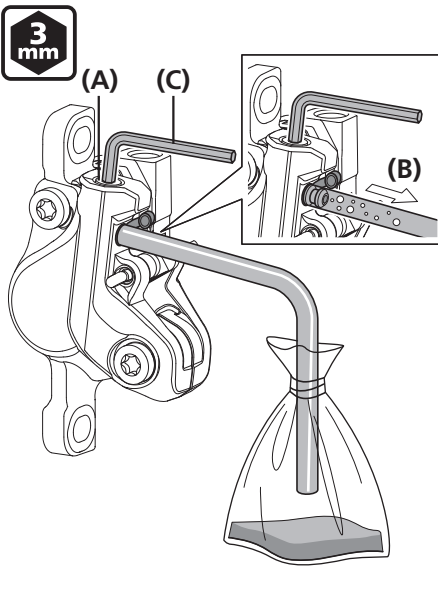

Loosen the bleed screw.

After a little while, the oil and air bubbles will flow naturally from the bleed nipple into the tube.

This way it will be possible to easily extract the greater part of the air bubbles remaining inside the brake system.

- (A) Bleed screw
- (B) Air bubbles
- (C) 3 mm hexagon wrench

 **TECH TIPS**

It may be effective to shake the brake hose gently, tap the reservoir tank or brake calipers gently with a screwdriver, or move the position of the calipers at this time.

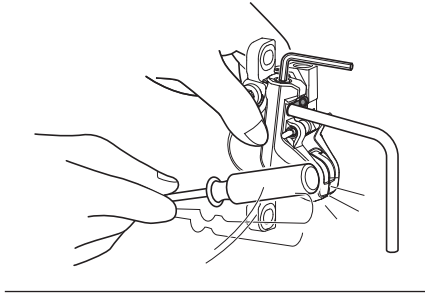

▶▶ Adding SHIMANO genuine mineral oil and bleeding air

The level of liquid inside the oil funnel drops at this time, so keep filling the funnel with oil to maintain the level of liquid so that air is not drawn in.

**7**

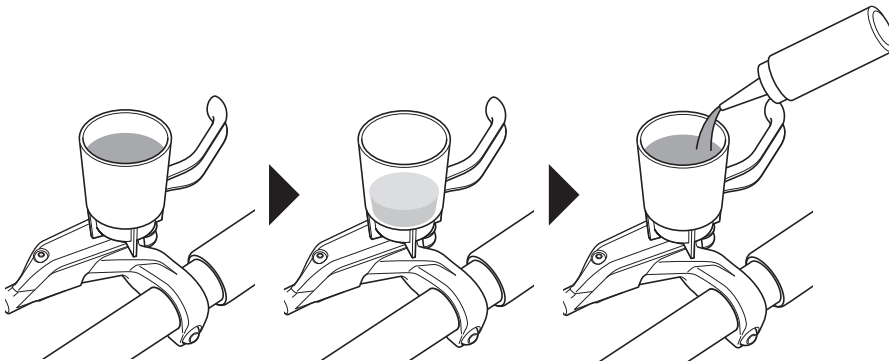

**8**

Once no more air bubbles come from the bleed nipple, temporarily close the bleed screw.

**9**

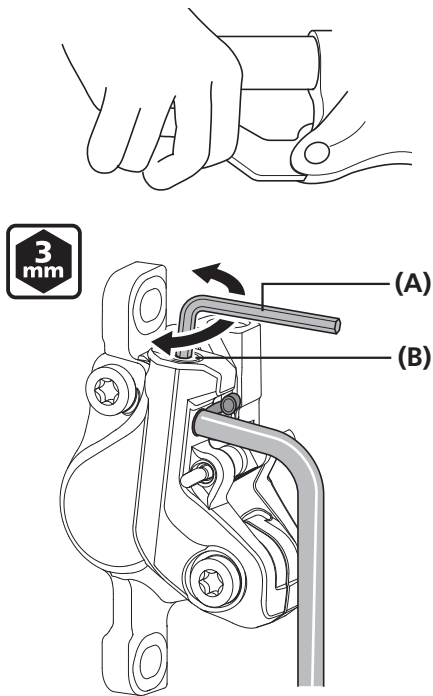

With the brake lever depressed, open and close the bleed screw in rapid succession (for approximately 0.5 seconds each time) to release any air bubbles which may be in the brake calipers.

Repeat this procedure about 2 to 3 times.

Then tighten the bleed screw again.

- (A)** 3 mm hexagon wrench
- (B)** Bleed screw

Tightening torque	
	4 - 6 N·m

▶▶ Adding SHIMANO genuine mineral oil and bleeding air

10

If the brake lever is then operated, air bubbles in the system will rise up through the port into the oil funnel.

Once the bubbles stop appearing, depress the brake lever as far as it will go.

Under normal conditions, lever action should feel stiff at this point.

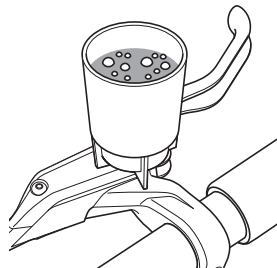

Lever operation

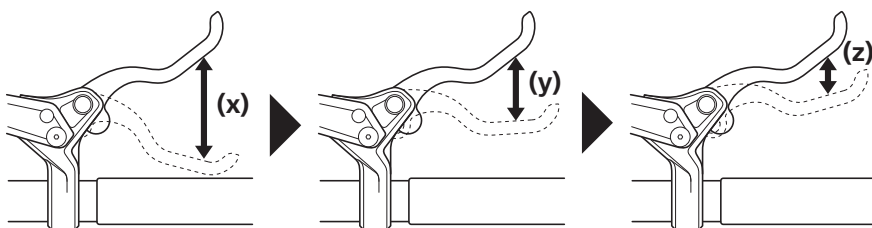

- (x) Loose
- (y) Slightly stiff
- (z) Stiff

**NOTICE**

If the lever does not become stiff, repeat the procedures from step 5.

11

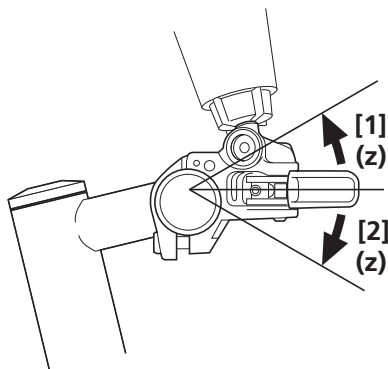

Set the lever unit to the horizontal position as shown in the illustration and tilt it 30 degrees in direction [1]; then carry out step 10 to check that there is no air remaining.

Next, tilt the lever unit 30 degrees in direction [2], and carry out step 10 again to check that there is no air remaining.

If any air bubbles appear, repeat the above procedure until they stop appearing.

- (z) 30°

12

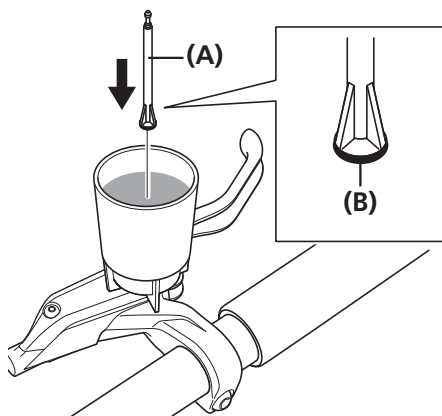

Plug the oil funnel with the oil stopper so that the O-ring mounted side is facing downward.

- (A) Oil stopper
- (B) O-ring

▶▶ Adding SHIMANO genuine mineral oil and bleeding air

**13**

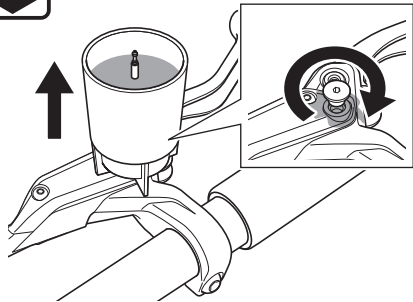

Remove the oil funnel while it is still plugged with the oil stopper and then tighten the bleed screw while letting oil flow out to make sure no air bubbles remain inside the reservoir tank.

At this point, use a clean rag to prevent oil from flowing out to the surrounding areas.

**14**



Wipe away any oil that has overflowed.

**15**

Finally, after removing the bleeding spacer and installing the pads and the pad spacer, depress the brake lever several times to check that the brake lever is operating normally and there are no fluid leaks from the brake hose or the system.

**Tightening torque**



**0.5 - 1 N·m**

**NOTICE**

Do not operate the brake lever. If operated, there is a risk of air bubbles entering the cylinder.

# ■ Replacing the brake hose

## Brake lever side

### NOTICE

If there is a marking as shown in the illustration, refer to the section "Replacing the brake hose (easy hose joint system)" in General Operations.

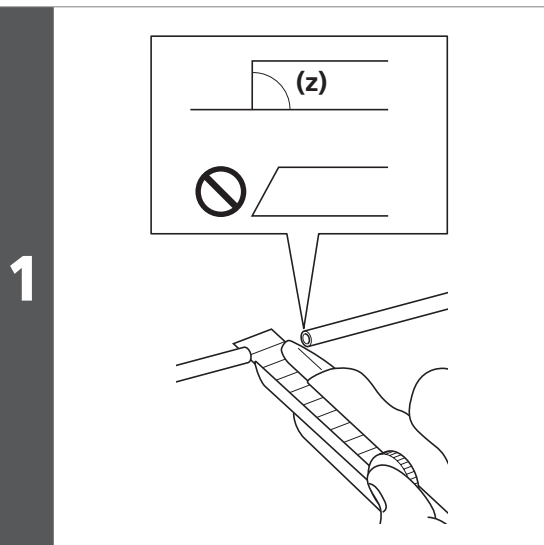
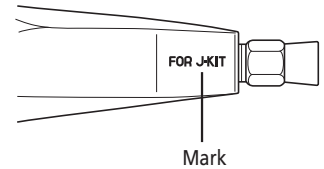

Use a utility knife or other cutting tool to cut the brake hose.

**(z)** 90°

### NOTICE

Use the utility knife safely and correctly in accordance with its instruction manual.



### TECH TIPS

If you are using TL-BH62, refer to the manual accompanying the product.

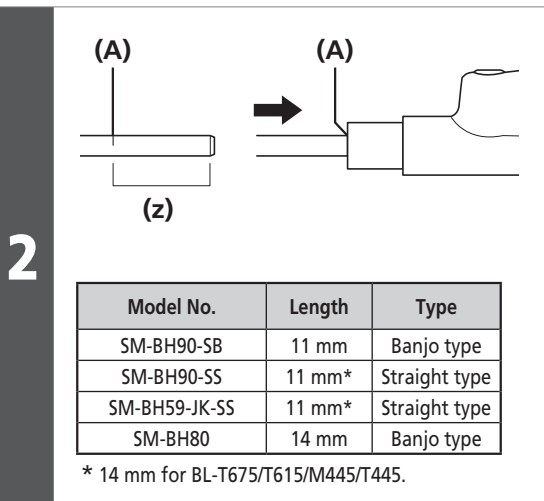

In order to check that the ends of the brake hose are fitted securely into the base of the brake hose mounts of the brake calipers and brake lever, make marks on the brake hose beforehand as shown in the illustration. (As a guide, the length of brake hose inside the mount should be approximately 11 mm, measured from the cut end of the brake hose.)

**(z)** Approx. 11 mm

**(A)** Mark

▶▶ Replacing the brake hose

**3**

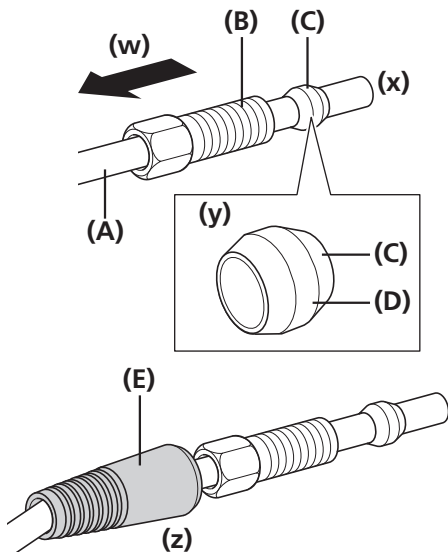

Pass the brake hose through the connecting bolt and olive.

- (w)** Direction of insertion
- (x)** Cut end
- (y)** Grease the outside of the olive.
- (z)** Attach the cover to the connecting bolt for the brake lever.

- (A)** Brake hose
- (B)** Connecting bolt
- (C)** Olive
- (D)** Premium Grease
- (E)** Cover

**4**

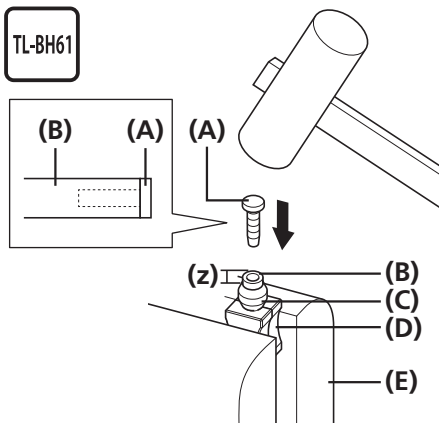

Use a tapered tool to smooth out the inside of the cut end of the brake hose, and mount the connector insert.

Attach the brake hose to the TL-BH61 as shown in the illustration, secure the TL-BH61 in a vise, and then use a hammer or similar tool to knock the connector insert in firmly until the base of the connector insert touches the end of the brake hose.

If the end of the brake hose is not touching the base of the connector insert, the brake hose may become disconnected or fluid leaks may occur.

- (z)** SM-BH90: 1 mm  
SM-BH59/BH80  
(YM-BH81): 4 mm

- (A)** Connector insert
- (B)** Brake hose
- (C)** Olive
- (D)** TL-BH61
- (E)** Vise

**5**

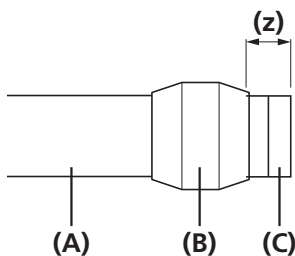

After checking that the olive is positioned as shown in the illustration, apply Premium Grease to the threads of the connecting bolt.

- (z)** SM-BH90: 2 mm  
SM-BH59/BH80  
(YM-BH81): 5 mm

- (A)** Brake hose
- (B)** Olive
- (C)** Connector insert

▶▶ Replacing the brake hose

**6**

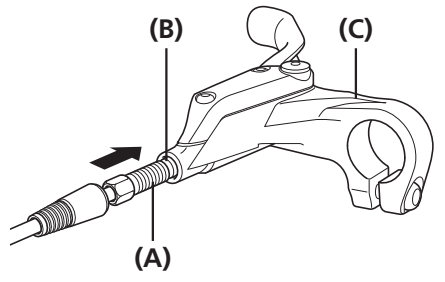

Attach the brake hose to the brake lever as shown in the illustration.

(A) Connecting bolt  
(B) Olive  
(C) Brake lever

**7**

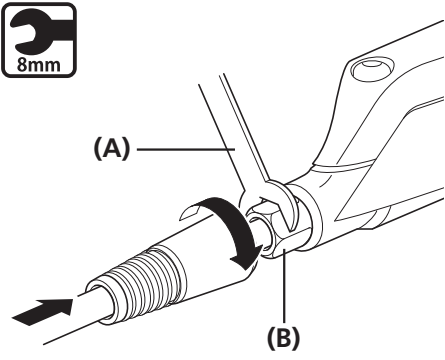

While pushing the brake hose, tighten the connecting bolt.

(A) 8 mm spanner  
(B) Connecting bolt

- (A) Connecting bolt
- (B) Olive
- (C) Brake lever

- (A) 8 mm spanner
- (B) Connecting bolt

Tightening torque	
	5 - 7 N·m

**Caliper side**

Mount the connecting bolt, the olive, and the connector insert by following the same procedure as for the brake lever.  
Use an 8 mm spanner to secure the connecting bolt.

**1**

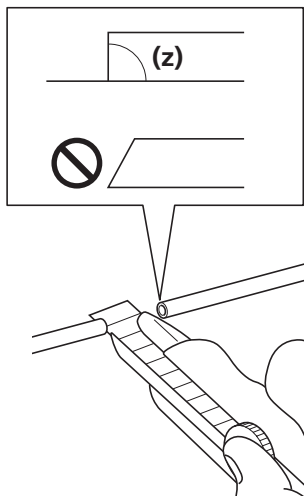

Use a utility knife or other cutting tool to cut the brake hose.

**(z)** 90°

**NOTICE**

Use the utility knife safely and correctly in accordance with its instruction manual.



If you are using TL-BH62, refer to the manual accompanying the product.

**2**

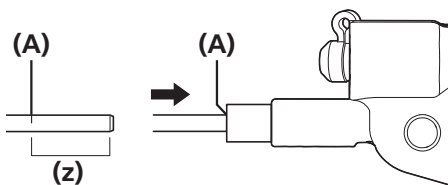

In order to check that the ends of the brake hose are fitted securely into the base of the brake hose mounts of the brake calipers and brake lever, make marks on the brake hose beforehand as shown in the illustration. (As a guide, the length of brake hose inside the mount should be approximately 14 mm, measured from the cut end of the brake hose.)

**(z)** Approx. 14 mm

**(A)** Mark

Model No.	Length	Type
SM-BH90-SS	11 mm*	Banjo type
SM-BH59-JK-SS	11 mm*	Straight type

\* 14 mm for BR-T675/T615/M446.

**3**

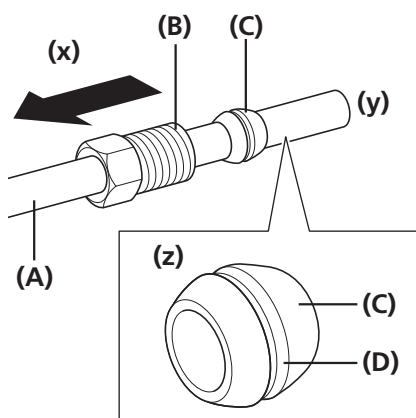

Pass the brake hose through the connecting bolt and olive.

**(x)** Direction of insertion

**(y)** Cut end

**(z)** Grease the outside of the olive.

**(A)** Brake hose

**(B)** Connecting bolt

**(C)** Olive

**(D)** Premium Grease

▶▶ Replacing the brake hose

**4**

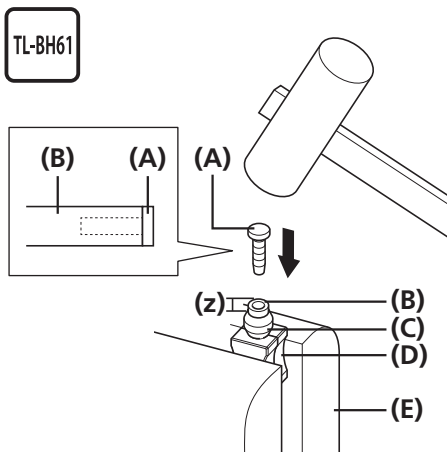

Use a tapered tool to smooth out the inside of the cut end of the brake hose, and mount the connector insert.

Attach the brake hose to the TL-BH61 as shown in the illustration, secure the TL-BH61 in a vise, and then use a hammer or similar tool to knock the connector insert in firmly until the base of the connector insert touches the end of the brake hose.

If the end of the brake hose is not touching the base of the connector insert, the brake hose may become disconnected or fluid leaks may occur.

**(z)** 4 mm

- (A)** Connector insert
- (B)** Brake hose
- (C)** Olive
- (D)** TL-BH61
- (E)** Vise

**5**

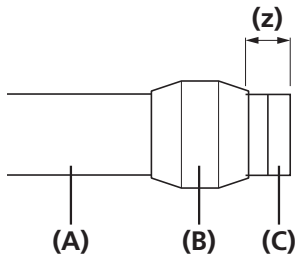

After checking that the olive is positioned as shown in the illustration, apply Premium Grease to the threads of the connecting bolt.

**(z)** 5 mm

- (A)** Brake hose
- (B)** Olive
- (C)** Connector insert

**6**

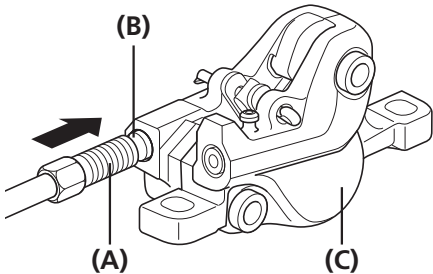

Attach the brake hose to the brake calipers as shown in the illustration.

- (A)** Connecting bolt
- (B)** Olive
- (C)** Brake caliper

**NOTICE**

Do not let the brake hose become twisted when installing it. Make sure that the calipers and brake levers are in the positions shown in the illustrations.

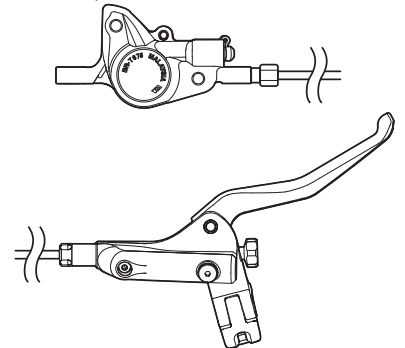

**Straight type**

7

While pushing the brake hose, tighten the connecting bolt.

- (A) 8 mm spanner
- (B) Connecting bolt

Tightening torque	
	5 - 7 N·m

**Banjo type**

7

XTR/DEORE XT (BR-M8000/BR-M785) /SLX

- (A) Brake hose
- (B) Banjo
- (C) O-ring
- (D) 4 mm hexagon wrench

Tightening torque	
	8 - 10 N·m

7

SAINT/ZEE/DEORE XT (BR-M8020)

- (A) Brake hose
- (B) Banjo
- (C) O-ring
- (D) 3 mm hexagon wrench

Tightening torque	
	4 - 6 N·m

## ■ Replacing the brake pads

Brake pad	BR-M9000/M9020/M987/M820/ M8000/M8020/M785	BR-M675/M640/M615/MT520	BR-M447/M4050/M395/T675/T615/ M3050
Pad position (from top)	x	x	-
Pad axle	x	-	-
Pad pin	-	x	x

When replacing the brake pad from the top (when pushing back the piston), refer to Replacement of the brake pads in the Maintenance section of General Operations.

### When replacing the brake pads from the bottom (BR-M447/M4050/M395/T675/T675B/T615/M3050)

#### NOTICE

- This brake system is designed to automatically adjust the clearance between the disc brake rotor and the brake pads by the piston gradually protruding according to the wear of the brake pads; therefore, when you replace the brake pads, you need to push back the piston.
- If oil adheres to the brake pads, if the brake pads are worn down to a thickness of 0.5 mm, or if the brake pad presser springs are interfering with the disc brake rotor, replace the brake pads.

**1**

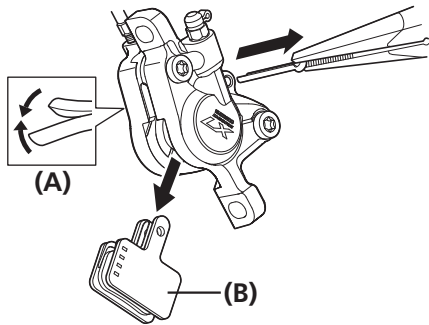

Remove the wheel from the frame, and remove the brake pads as shown in the illustration.

- (A) Split pin
- (B) Brake pad

**2**

Clean the pistons and surrounding area.

**3**

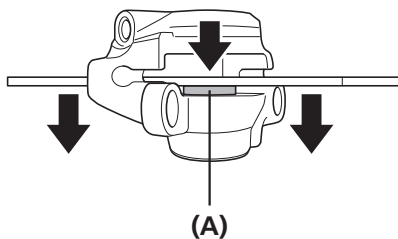

Use a flat-shaped tool to push the pistons straight back in as far as they will go, while being careful not to twist the pistons.

Do not push the pistons with a sharp tool. The pistons may be damaged.

- (A) Piston

#### NOTICE

Note that there is a risk of oil overflowing from the reservoir tank.

**▶▶ Replacing the brake pads**

**4**

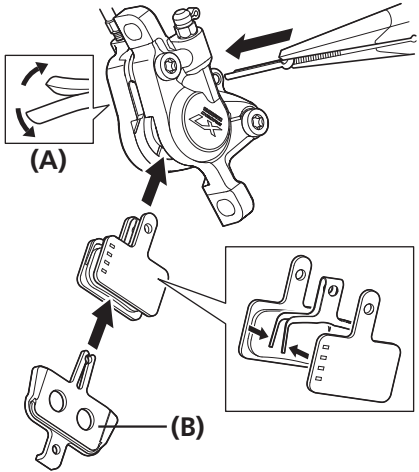

Install the new brake pads, and then install the pad spacers (red).

After this, bend open the split pin.

- (A)** Split pin  
**(B)** Pad spacer (red)

**5** Depress the brake lever several times to check that the operation becomes stiff.

**6** Remove the pad spacers.

**7** Install the wheel, and then check that there is no interference between the disc brake rotor and brake pads.

**8** After checking the oil level, close the reservoir tank cover.

**9** Return the brake lever to its original position.

**NOTICE**

If they touch, adjust while referring to the section "INSTALLATION (HYDRAULIC DISC BRAKES)" in General Operations.

## ■ Designated parts for magnesium products

### NOTICE

Do not use any parts other than those listed below with BR-M9000, BR-M987 or BL-M9000, BL-M987, which are made of magnesium. Otherwise the rusting process will accelerate.

#### BR-M987

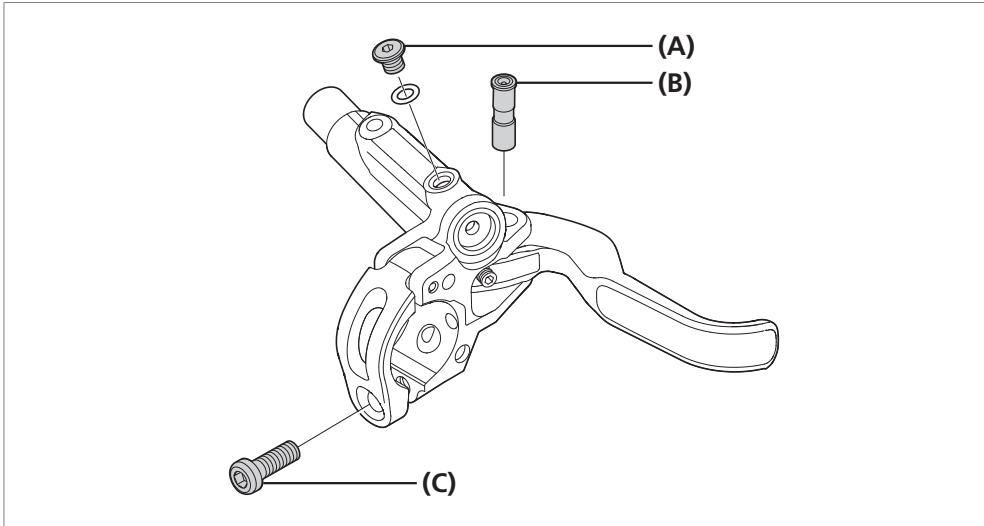

- (A)** Bleed screw
- (B)** Lever axle
- (C)** Clamp bolt

#### SM-BH90-SBM/BR-M987

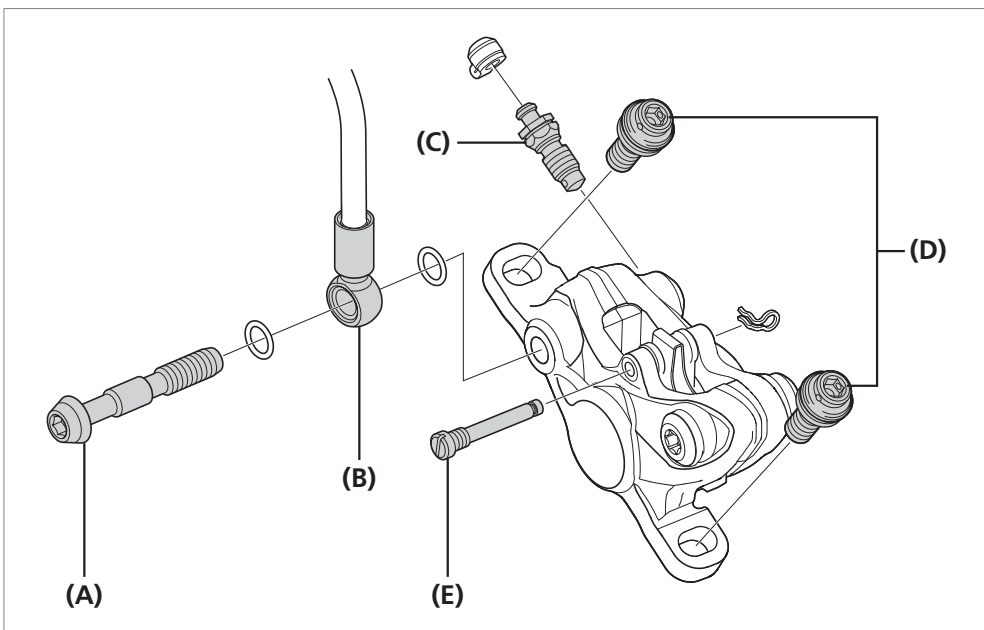

- (A)** Banjo bolt
- (B)** Brake hose (Banjo)
- (C)** Bleed nipple
- (D)** Fixing bolt
- (E)** Pad axle

**For customers who use this product with SM-MA90-F180P/P**

When using BR-M987 with SM-MA90-F180P/P, be sure to use a surface-treated (silver) R washer.

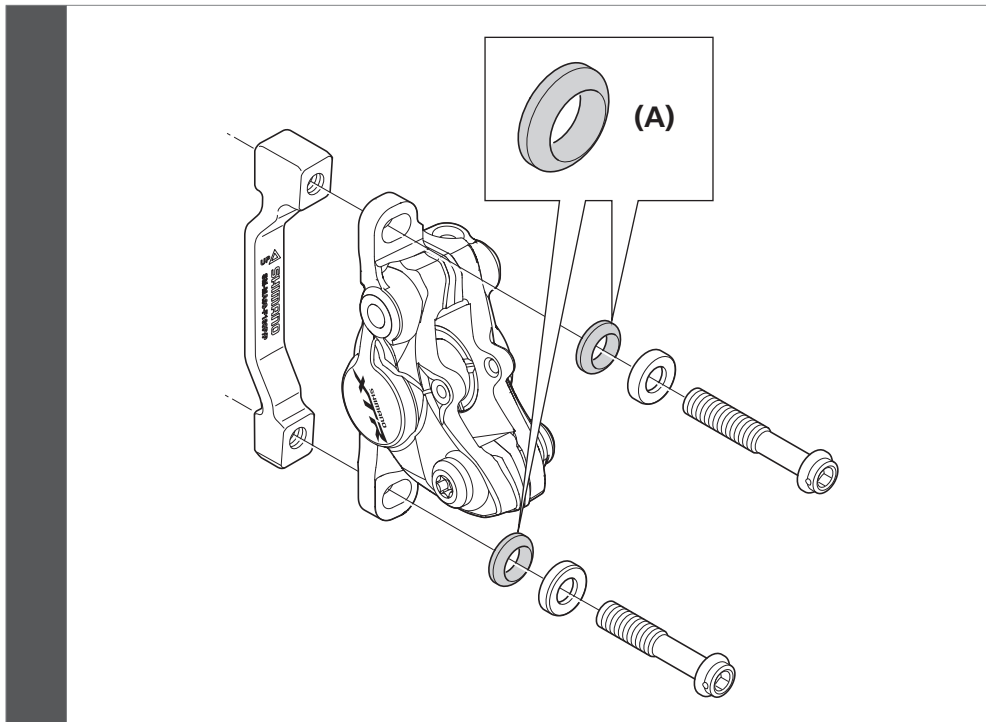

**(A)** R washer

**NOTICE**

Do not use non-surface-treated (gray) R washers.  
 S-part No. ISMMA90F180PP (SM-MA90-F180P/P) and S-part No. ESMMAF180PP2 (SM-MA-F180P/P2) are non-surface-treated (gray) R washers. Do not use them.  
 (R washers S-part No. ISMMA90F180PPC and SHIMANO code No. Y8LF12000 (SM-MA90-F180P/P) are surface-treated (silver) and therefore usable.)

	S-part#	Surface-treatment for R washers	Usage
SM-MA90-F180P/P	ISMMA90F180PPC	Silver	OK
	ISMMA90F180PP	Gray	Not OK
SM-MA-F180P/P2	ESMMAF180PP2	Gray	Not OK

**Service parts (R washer)**

ITEM No.	SHIMANO CODE No.	DESCRIPTION	Surface-treatment for R washers	Usage
28	Y8LF12000	R-Washer A	Silver	OK

# SHIMANO

## **SHIMANO NORTH AMERICA BICYCLE, INC.**

One Holland, Irvine, California 92618, U.S.A. Phone: +1-949-951-5003

## **SHIMANO EUROPE B.V.**

High Tech Campus 92, 5656 AG Eindhoven, The Netherlands Phone: +31-402-612222  
Only EU General Contact : [contactshimano@shimano-eu.com](mailto:contactshimano@shimano-eu.com)

## **SHIMANO INC.**

3-77 Oimatsu-cho, Sakai-ku, Sakai City, Osaka 590-8577, Japan

Please note: specifications are subject to change for improvement without notice. (English)

© Mar. 2025 by SHIMANO INC. ITP