

SHIMANO ULTEGRA Front Chainwheel
FC-6503

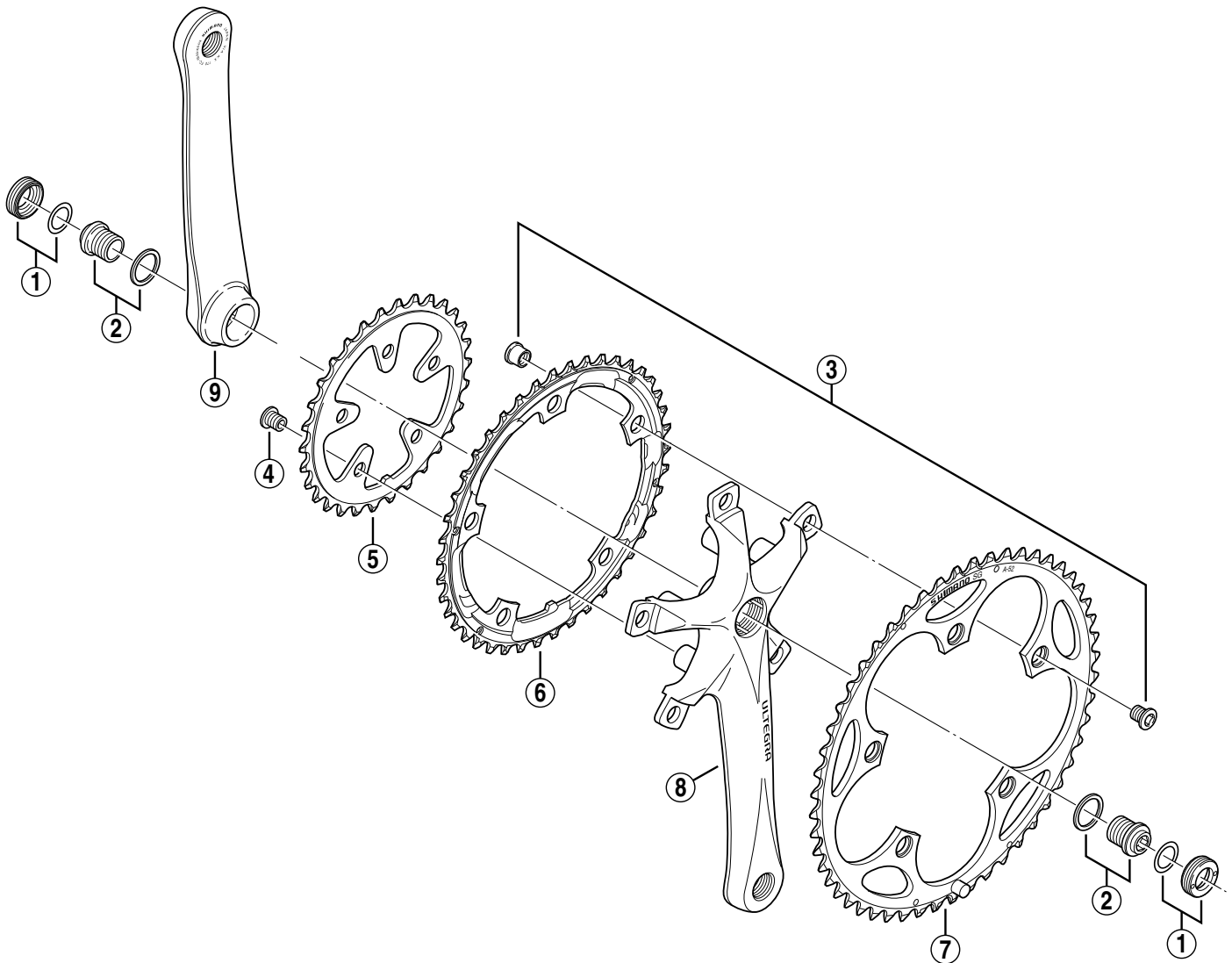

• Bolt circle diameter: 130 mm...(For outer gear and middle gear), 74 mm...(For inner gear)

Q'TY	ITEM NO.	SHIMANO CODE NO.	DESCRIPTION
	* 1	Y-16U 98010	Crank Arm Cap & Plastic Washer
	2	Y-16P 98010	Crank Arm Fixing Bolt & Washer
	* 3	Y-16U 98020	Double Gear Fixing Bolt (M8 x 8.5) & Nut (5 sets)
	* 4	Y-16U 98030	Inner Gear Fixing Bolt (M8 x 8.5 / 5 pcs.)
	5	Y-16U 30000	Chainring 30T (Silver)
	6	Y-16T 9A420	Chainring 42T (Silver)
	7	Y-16T 9A520	Chainring 52T (Silver)
		Y-16U 07000	Right Hand Crank Arm 165 mm
		Y-16U 06000	Right Hand Crank Arm 167.5 mm
	8	Y-16U 05000	Right Hand Crank Arm 170 mm
		Y-16U 04000	Right Hand Crank Arm 172.5 mm
		Y-16U 03000	Right Hand Crank Arm 175 mm
		Y-16T 07100	Left Hand Crank Arm 165 mm
		Y-16T 06100	Left Hand Crank Arm 167.5 mm
	9	Y-16T 05100	Left Hand Crank Arm 170 mm
		Y-16T 04100	Left Hand Crank Arm 172.5 mm
		Y-16T 03100	Left Hand Crank Arm 175 mm