

# Dealer's Manual

ROAD	GRAVEL	MTB
E-BIKE	LIFESTYLE	GENERAL

## Crankset

### CUES

FC-U8000  
FC-U6000  
FC-U6010  
FC-U6030  
FC-U6040  
FC-U4000  
FC-U4010

### SHIMANO ESSA

FC-U2000

### Bottom Bracket

BB-MT801  
BB-MT800-PA  
BB-MT501  
BB-MT500-PA  
BB-RS501  
BB-RS500-PB  
BB-UN300  
BB-UN101  
BB-UR400

---

## Contents

<b>IMPORTANT NOTICE</b> .....	<b>3</b>
<b>TO ENSURE SAFETY</b> .....	<b>4</b>
<b>List of tools to be used</b> .....	<b>8</b>
<b>Installation/removal</b> .....	<b>9</b>
Combination of crankset and bottom bracket .....	9
Installing/removing the bottom bracket .....	10
• Tool combination chart .....	10
• Installation .....	11
• Removal .....	16
Installing the crankset .....	18
• 2-PIECE CRANKSET (model with an axle on the left crank arm) .....	18
• HOLLOWTECH II / 2-PIECE CRANKSET .....	19
• Square type .....	21
Removing the crankset .....	23
• 2-PIECE CRANKSET (model with an axle on the left crank arm) .....	23
• HOLLOWTECH II / 2-PIECE CRANKSET .....	24
• Square type .....	25
<b>Maintenance</b> .....	<b>26</b>
Replacing the chainring.....	26
• Single chainring type .....	26
• Double chainring type .....	27
Installing the chain guard .....	30
• FC-U8000-2 / FC-U6000-1 / FC-U6000-2 / FC-U6000-2B / FC-U6010-2 / FC-U4000-1 / FC-U4010-2 / FC-U4010-2B / FC-U2000-1 .....	30
• FC-U8000-1 .....	30

# IMPORTANT NOTICE

- **This dealer's manual is intended primarily for use by professional bicycle mechanics.**

Users who are not professionally trained for bicycle assembly should not attempt to install the components themselves using the dealer's manuals.



If any part of the information on the manual is unclear to you, do not proceed with the installation. Instead, contact your place of purchase or a distributor for assistance.

- Make sure to read all manuals included with each product.
- Do not disassemble or modify the product other than as stated in the information contained in this dealer's manual.
- All manuals and technical documents are accessible online at <https://si.shimano.com>.
- For consumers who do not have easy access to the internet, please contact a SHIMANO distributor or any of the SHIMANO offices to obtain a hardcopy of the user's manual.
- Please observe the appropriate rules and regulations of the country, state or region in which you conduct your business as a dealer.

**For safety, be sure to read this dealer's manual thoroughly before use, and follow it for correct use.**

The following instructions must be observed at all times in order to prevent personal injury and physical damage to equipment and surroundings.

The instructions are classified according to the degree of danger or damage which may occur if the product is used incorrectly.

 <b>DANGER</b>	Failure to follow the instructions will result in death or serious injury.
 <b>WARNING</b>	Failure to follow the instructions could result in death or serious injury.
 <b>CAUTION</b>	Failure to follow the instructions could cause personal injury or physical damage to equipment and surroundings.

# TO ENSURE SAFETY

## WARNING

- **Be sure to follow the instructions provided in the manuals when installing the product.**  
Only use SHIMANO genuine parts. If a component or replacement part is incorrectly assembled or adjusted, it can lead to component failure and cause the rider to lose control and crash.
-  Wear approved eye protection while performing maintenance tasks such as replacing components.

### Be sure to also inform users of the following:

- Never use alkali- or acid-based solvents such as rust cleaners. If those solvents are used the chain might break and cause serious injury.
- Clean the chain with an appropriate chain cleaner regularly. Intervals between maintenance depend on the use and riding circumstances.
- Check that there are no cracks in the crank arms before riding the bicycle. If there are any cracks, the crank arm may break and you may fall off the bicycle.
- Be careful not to let the hemming of your clothes get caught in the chain while riding. Otherwise, you may fall off the bicycle.
- Check the chain for any damage (deformation or cracking), skipping, or other abnormalities such as unintended gear shifting. The chain may break, and you may fall.

### For installation to the bicycle and maintenance

- Install the inner cover correctly. If it is not installed correctly, the axle may rust and become damaged, and the bicycle may fall over and serious injury may occur as a result.
- The two crank fixing screws of the left crank arm should be tightened alternately in stages rather than each fully tightened at once. Use a torque wrench to check that the tightening torques are within the range of 12 - 14 N·m. Also, after riding approximately 100 km (60 miles), use a torque wrench to re-check the tightening torques. Thereafter, continue to check the tightening torques periodically. If the tightening torques are too weak or if the mounting screws are not tightened alternately in stages, the left crank arm may come off and the bicycle may fall over, and serious injury may occur as a result.
- Re-checking the tightening torque of the crank arm is necessary when the crank arm is subjected to strong blows from a fall. If riding when the tightening torque is weak due to a strong blow, the crank arm could detach and you may fall off the bicycle.

## CAUTION

### Be sure to also inform users of the following:

- Be careful not to touch the teeth of the chainrings. There is a danger of injury.



## NOTICE

### Be sure to also inform users of the following:

- Be sure to keep turning the crank arm during the shifter operation.

## TO ENSURE SAFETY

- When the chain is in any of the positions shown in the figures, the chain may come into contact with the chainring or front derailleur and generate noise. If noise is a problem, shift the chain onto the next largest sprocket or the one after it.

	Double
Chainring	
Sprocket	

- Check that there is no excess play or looseness in any fastening sections before riding the bicycle. Also, be sure to retighten the crank arm and pedals at periodic intervals.
- Use a neutral detergent to clean the crank arms and the bottom bracket. Using alkaline or acidic detergents may cause discoloration.
- If pedaling performance does not feel normal due to an abnormal noise, etc., contact your place of purchase.
- Do not wash the surrounding area of the bottom bracket with a high-pressure wash. Water may enter the bearing section and cause noise or adhesion.
- If you feel any excess play in the bearing section, the bottom bracket should be replaced.
- The chainrings should be periodically washed with a neutral detergent. In addition, cleaning the chain with neutral detergent and lubricating it can be an effective way of extending the life of the chainrings and the chain.
- The cuffs of your clothing may get dirty from the chain while riding.
- This product is not warranted against damage caused by improper use, abuse, or issues resulting from a crash, unless the circumstance was caused by a manufacturing problem.
- Products are not guaranteed against natural wear and deterioration from normal use and aging.
- For maximum performance we highly recommend SHIMANO lubricants and maintenance products.

### For installation to the bicycle and maintenance

- When installing the pedals, apply a small amount of grease to the threads to prevent the pedals from seizing. Use a torque wrench to securely tighten the pedals. Tightening torque is 35 - 55 N·m. The right crank arm has a right-hand thread, and the left crank arm has a left-hand thread.
- If the bottom bracket shell is not parallel, gear shifting performance will drop.
- If the chain keeps coming off the gears during use, replace the chainrings and the chain.
- When installing the left- and right-hand cups, apply grease and be sure to install the inner cover. Otherwise, the waterproofing performance will worsen.
- To ensure the best performance, be sure to use only the recommended type of chain.

Crankset	Recommended chain
FC-U8000	CN-HG701-11
FC-U6000 / FC-U6010 / FC-U6030 / FC-U6040 / FC-U4000 / FC-U4010	CN-LG500
FC-U2000	CN-HG40

- If a squeaking noise is heard coming from the bottom bracket axle and the left crank arm connector, apply grease to the fastening section, then tighten it to the specified torque.

**TO ENSURE SAFETY**

- Only use chainring combinations listed below. If other chainring combinations are used, it can create poor shifting and cause the chain to jam, resulting in damage to the bicycle.

FC-U8000-2 FC-U6010-2		Top		
		46T BM		
Low	32T BM	X		

FC-U6040-2 FC-U6030-2		Top	
		50T NT	46T NW
Low	34T NT	X	-
	32T NW	-	X

FC-U6000-2 / 2B		Top	
		46T BN	36T BK
Low	30T BN	X	-
	22T BK	-	X

FC-U4010-2 / 2B		Top		
		46T	40T	36T
Low	30T	X	-	-
	26T	-	X	-
	22T	-	-	X

FC-U4000-2 / 2B		Top	
		40T	36T
Low	26T	X	-
	22T	-	X























Single chainring	FC-U8000-1 FC-U6040-1 FC-U6030-1	FC-U6000-1	FC-U4000-1	FC-U2000-1
42T	X	X	X	-
40T	X	X	X	X
32T	-	X	X	X
30T	-	X	X	-

- Be sure to use only the applicable chain and bottom bracket.
- Apply grease to the bottom bracket before installing it.
- If you feel any excess play in the bottom bracket axle, the bottom bracket should be replaced.

The actual product may differ from the illustration because this manual is intended mainly to explain the procedures for using the product.

# List of tools to be used

The following tools are needed for installation, adjustment, and maintenance purposes.

Tool			
	4 mm hexagon wrench		TL-FC18
	5 mm hexagon wrench		TL-FC25
	8 mm hexagon wrench		TL-FC32
	Cross head screwdriver [#2]		TL-FC33
	17 mm spanner		TL-FC36
	Soft face mallet		TL-FC37
	Adjustable wrench		TL-BB12
	TL-FC10		TL-BB13
	TL-FC11		TL-UN66
	TL-FC15		TL-UN74
	TL-FC16		TL-UN74-S

# Installation/removal

## Combination of crankset and bottom bracket

Use the crankset and bottom bracket in the combinations shown below.



Crankset	Bottom bracket				
	BB-MT801 BB-MT501 BB-UR400	BB-MT800-PA BB-MT500-PA	BB-RS501	BB-RS500-PB	BB-UN300 BB-UN101
FC-U8000-1 FC-U8000-2 FC-U6000-1 FC-U6000-2 FC-U6000-2B FC-U6010-2 FC-U4010-2 FC-U4010-2B	X	X	-	-	-
FC-U6030-1 FC-U6030-2 FC-U6040-1 FC-U6040-2	-	-	X	X	-
FC-U4000-1 FC-U4000-2 FC-U4000-2B FC-U2000-1	-	-	-	-	X

# Installing/removing the bottom bracket

## Tool combination chart

The tools required for installing and removing the bottom bracket differ by model. Combine and use any of the tools specified in the table.

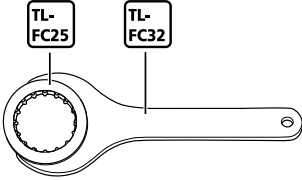
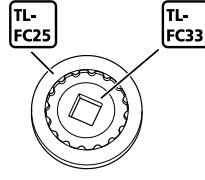
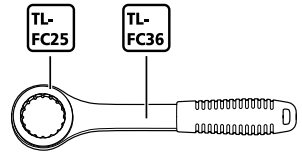
### BB-MT801

TL-FC25 & TL-FC32	TL-FC25 & TL-FC33
 <p>Diagram showing two tools: TL-FC25 (a ring with a serrated inner edge) and TL-FC32 (a long handle with a small hole at the end).</p>	 <p>Diagram showing two tools: TL-FC25 (a ring with a serrated inner edge) and TL-FC33 (a ring with a square hole in the center).</p>
TL-FC25 & TL-FC36	TL-FC37
 <p>Diagram showing two tools: TL-FC25 (a ring with a serrated inner edge) and TL-FC36 (a long handle with a serrated end).</p>	 <p>Diagram showing TL-FC37 (a ring with a square hole in the center).</p>

### BB-MT501 / BB-RS501 / BB-UR400

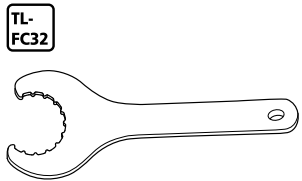
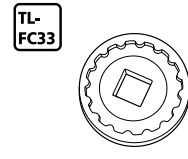
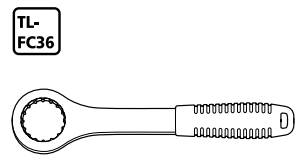
TL-FC32	TL-FC33
 <p>Diagram showing TL-FC32 (a ring with a serrated inner edge).</p>	 <p>Diagram showing TL-FC33 (a ring with a square hole in the center).</p>
TL-FC36	
 <p>Diagram showing TL-FC36 (a long handle with a serrated end).</p>	

## NOTICE

- When using an impact wrench on BB-MT801, use it in combination with TL-FC37. Using any other combinations will damage the tool.
- TL-FC25 may become damaged and unusable after repeated use.

- Check the possible installation positions when setting TL-FC25 in TL-FC32.

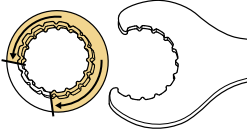
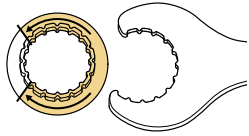

- Any installation position is possible for TL-FC33 / FC36.

## Installation

### HOLLOWTECH II / 2-PIECE CRANKSET

#### 1. Set the spacers.

- (1) Measure the width of the bottom bracket shell.

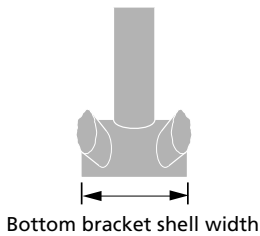

- (2) Prepare the required spacers as indicated in the table.

#### BB-MT801 / BB-MT501

Bottom bracket shell width	
68 mm	73 mm
<p>1.8 mm spacer 0.7 mm spacer 2.5 mm spacer</p> <p>Left Right</p>	<p>1.8 mm spacer 0.7 mm spacer</p> <p>Left Right</p>

#### BB-UR400

Bottom bracket shell width
68 mm

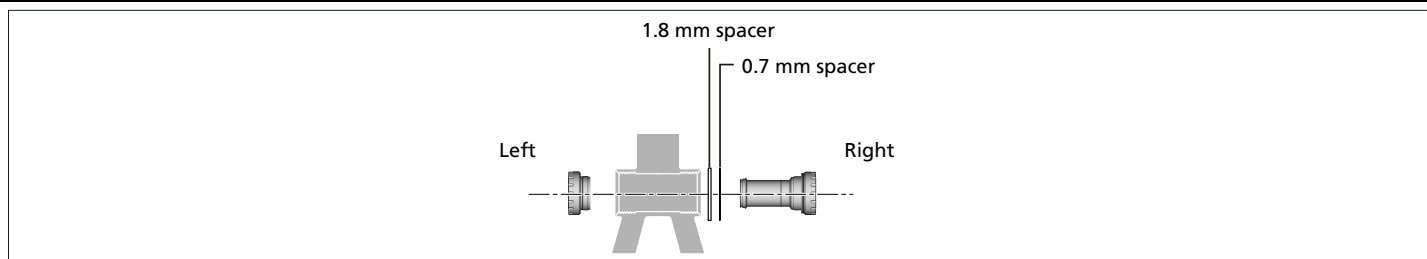

### Chain case stay type

Bottom bracket shell width	
68 mm	73 mm
<p><b>BB-MT801 / BB-MT501</b></p> <p>Left Right</p> <p>Chain case stay 0.7 mm spacer 2.5 mm spacer</p> <p><b>BB-UR400</b></p> <p>Left Right</p> <p>0.7 mm spacer Chain case stay</p>	<p>Left Right</p> <p>0.7 mm spacer Chain case stay</p>

### NOTICE

- BB-UR400 is not compatible with a bottom bracket shell width of 73 mm.
- If not using a chain case, use a 1.8 mm spacer.
- A 1.8 mm spacer and 0.7 mm spacer can be used together instead of a 2.5 mm spacer.
- No spacer is needed for BB-RS501.

## 2. Install the inner cover, left- and right-hand cups, and spacers.

- (1) Apply grease to the left- and right-hand cups.
- (2) Tighten the left- and right-hand cups. Refer to "[Tool combination chart](#)" in "Installing/removing the bottom bracket" for the SHIMANO original tool to use.

(1)

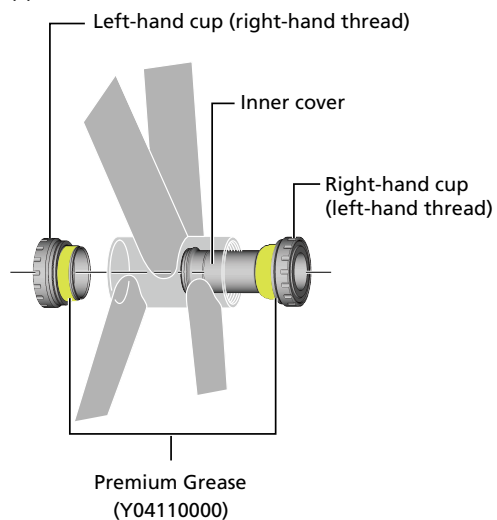

(2)

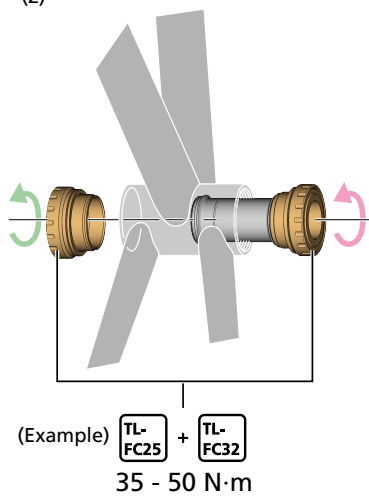

## NOTICE

- For bottom brackets that are compatible with a bottom bracket shell width of 70 mm (Italian standard), turn the right-hand cup clockwise (right-hand thread).

## Square type

### 1. Install the main body and left-hand cup.

First install the main body, then the left-hand cup.

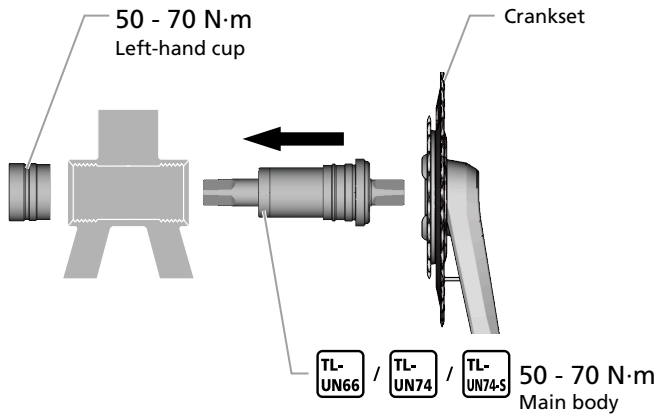

## NOTICE

- If the main body and left-hand cup are aluminum or steel, apply Premium Grease to them.

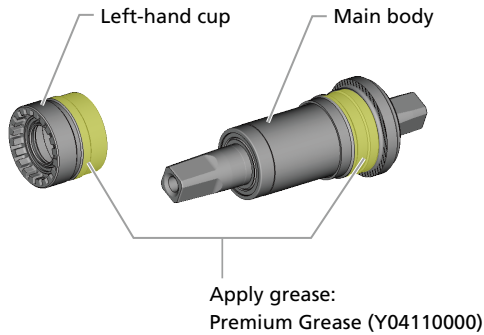

- If the main body and left-hand cup are plastic, do not apply grease to them.

## Press-fit bottom bracket

### 1. Set the bottom bracket and spacer.

- (1) Measure the width of the bottom bracket shell.

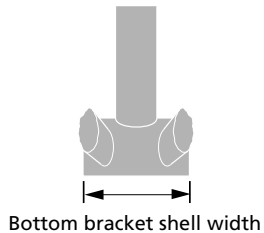

- (2) Prepare a spacer for the position indicated in the table.

Bottom bracket shell width	
89.5 mm	86.5 mm / 92 mm

Installation/removal  
Installing/removing the bottom bracket

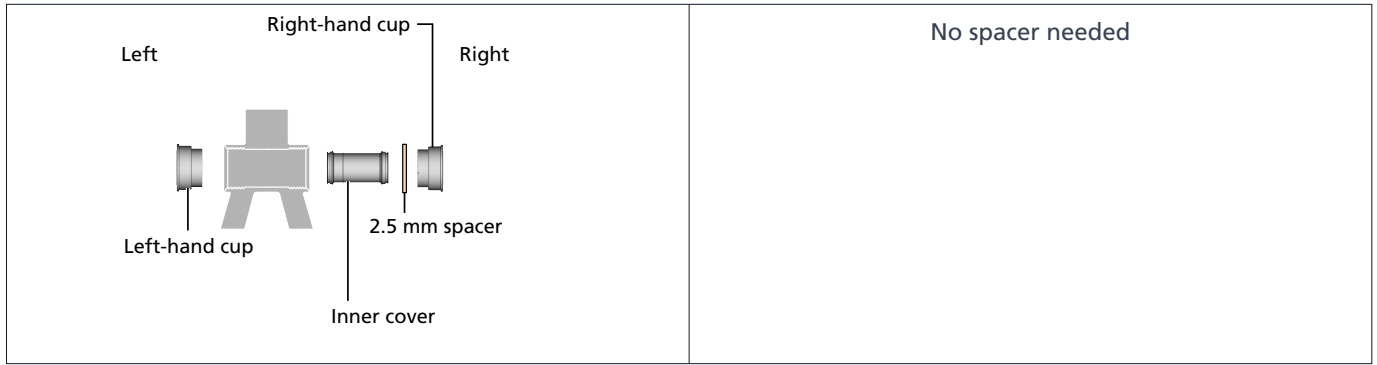

(3) Set the inner cover and left- and right-hand cups.

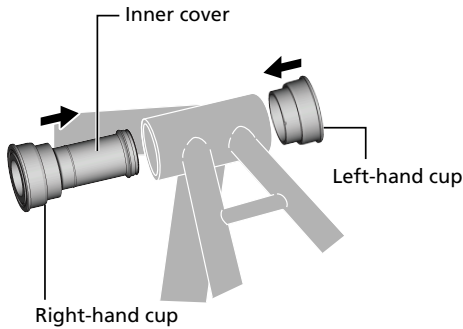

**NOTICE**

- If the frame has openings for the bottom bracket shell, attach an inner cover to prevent foreign objects from getting inside. If there are no openings, it can be installed without an inner cover.

2. Insert the SHIMANO original tool into the bottom bracket.

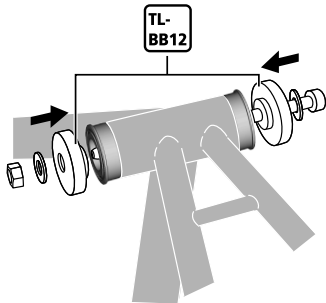

3. Press-fit the bottom bracket.

Make sure that the contact surface of the bottom bracket is parallel with the contact surface of the bottom bracket shell.

\* Press-fit until there is no more gap between the bottom bracket and the bottom bracket shell.

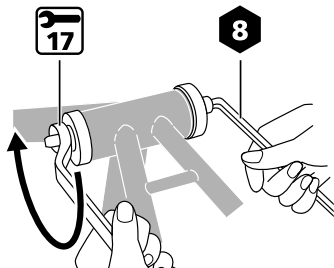

## Removal

### HOLLOWTECH II / 2-PIECE CRANKSET / square type

1. Perform the removal in the reverse order from “ [Installation](#) ” in “Installing/removing the bottom bracket.”

#### Press-fit bottom bracket

1. Insert the SHIMANO original tool into the bottom bracket.

- (1) Extend the flaps to taper the tip of the SHIMANO original tool.
- (2) Insert the SHIMANO original tool from the opposite side of the cup to remove.
- (3) As shown in the figure, press down on the protruding portion of the tip with your hand to expand the flaps.
- (4) Push the tool in further while continuing to press down on the tip, until the collar on the flaps engages with the cup.

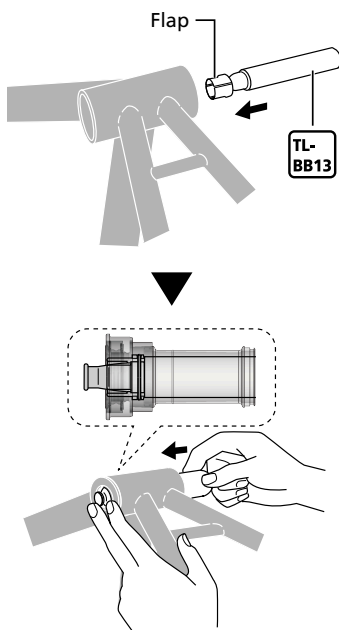

2. Push out the cup.

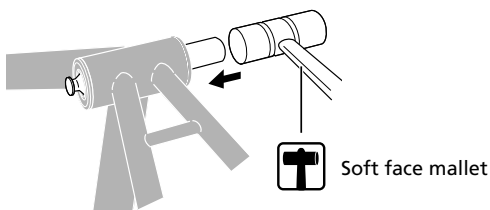

3. Remove the cup on the opposite side in a similar manner.

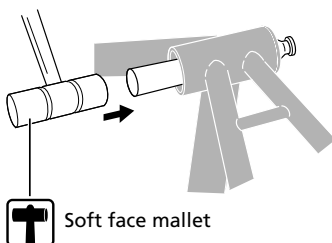

***NOTICE***

- Do not reuse the cups as they can be damaged during removal.

# Installing the crankset

Refer to "[Combination of crankset and bottom bracket](#)" in "Installation/removal" for the bottom bracket to use.

## 2-PIECE CRANKSET (model with an axle on the left crank arm)

**1. Completely tighten the adjustment nut.**

Turn the adjustment nut so it is tight against the left crank arm.

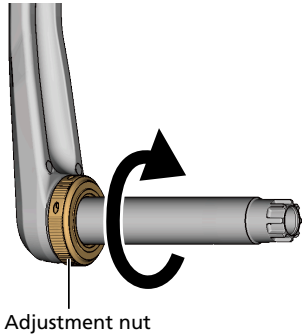

**2. Fully insert the left crank arm until it touches the bottom bracket.**

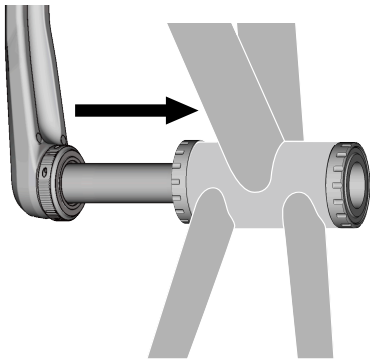

**3. Set the right crank arm unit onto the axle of the left crank arm.**

As shown in the figure, be sure to set the left and right crank arms so that they are aligned.

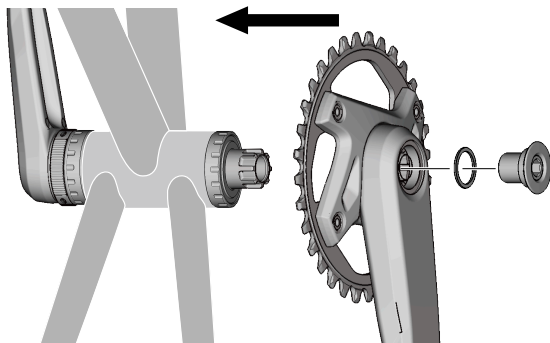

**4. Tighten the crank mounting screw.**

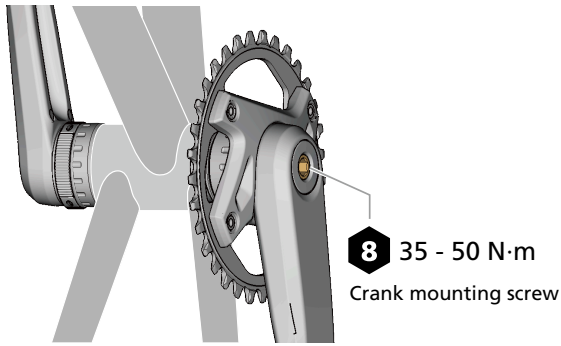

5. Insert the right crank arm unit until it securely touches the bottom bracket.

\* Confirm that there is no gap between the right crank arm unit and the bottom bracket.

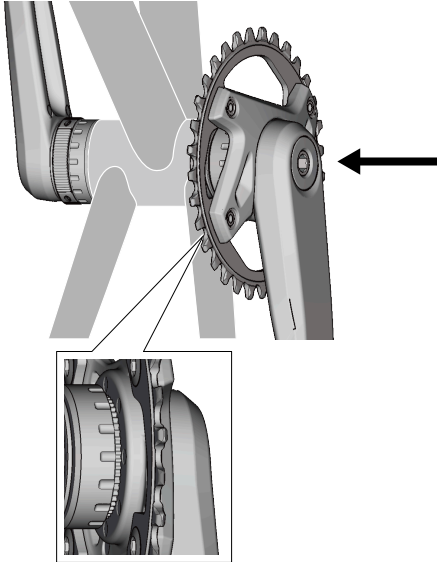

6. Turn the adjustment nut to remove any excess play between the crank arm and bottom bracket.

\* Turn the adjustment nut directly by hand or by inserting a tool such as a thin hexagon wrench into one of the holes. Confirm that there is no gap between the adjustment nut and the bottom bracket.

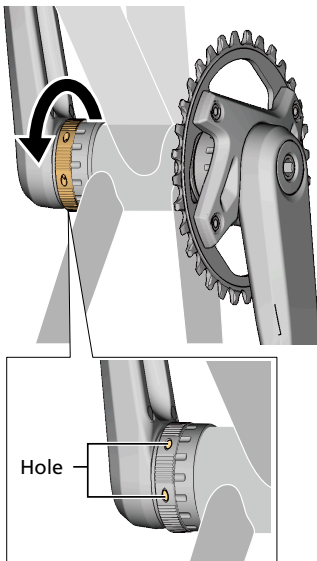

## HOLLOWTECH II / 2-PIECE CRANKSET

1. Fully insert the right crank arm unit until it touches the bottom bracket.

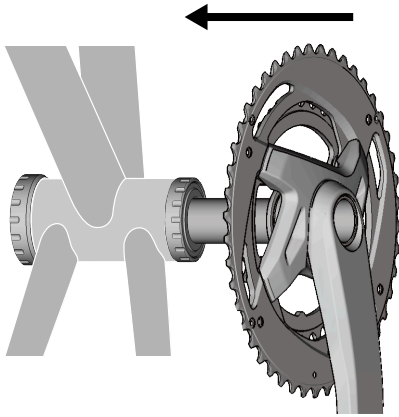

**2. Set the left crank arm onto the axle of the right crank arm unit.**

- (1) Apply grease to the axle of the right crank arm unit.
- (2) Align the wide section of the left crank arm spline with the wide section of the spline on the axle of the right crank arm unit.

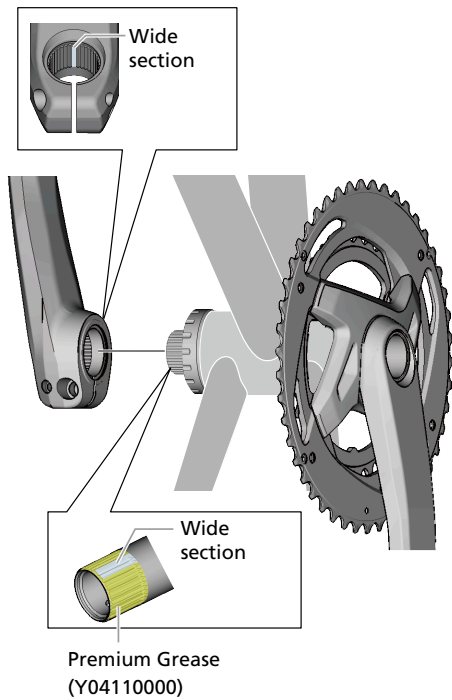

**3. Apply grease to the cap and tighten it.**

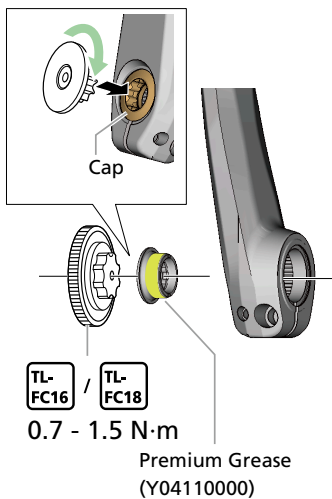

**4. Tighten the crank fixing screw to secure the crank arm.**

- (1) Set the stopper plate in the direction shown in the figure and push it in.
- (2) Check that the plate pin is securely inserted.
- (3) Tighten the two crank fixing screws of the left crank arm alternately until they reach the specified torque.

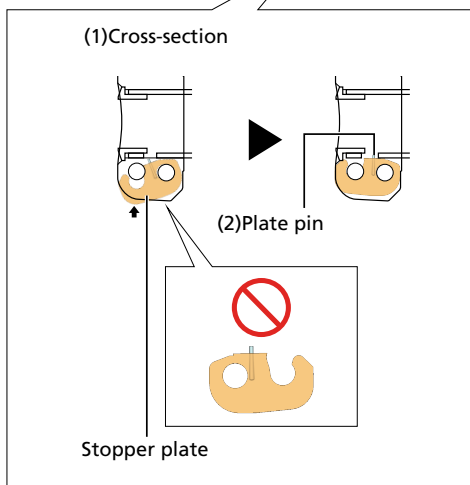
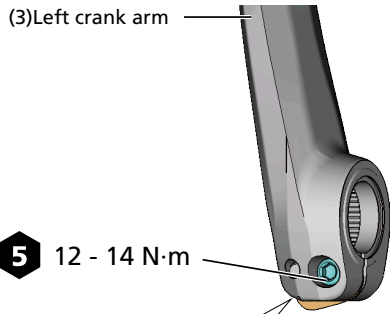

**TECH TIPS**

- Confirm that there is no gap or excess play between the crank arm and the bottom bracket, and perform the operation from step [3](#) again if there is.

**Square type**

- 1. Install the crankset.**

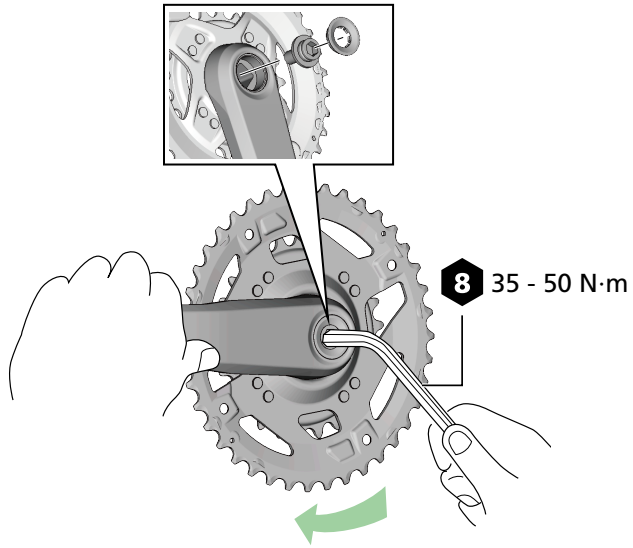

# Removing the crankset

## 2-PIECE CRANKSET (model with an axle on the left crank arm)

### 1. Loosen the crank mounting screw.

Remove the crank mounting screw and washer.

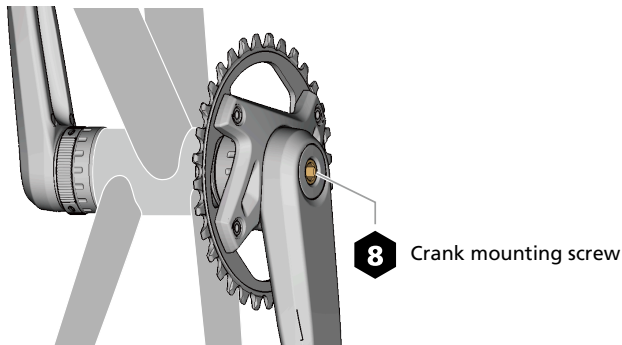

### 2. Install the SHIMANO original tool to the right crank arm unit.

When using TL-FC11

- Loosen the threads of the SHIMANO original tool, and install it to the right crank arm unit.

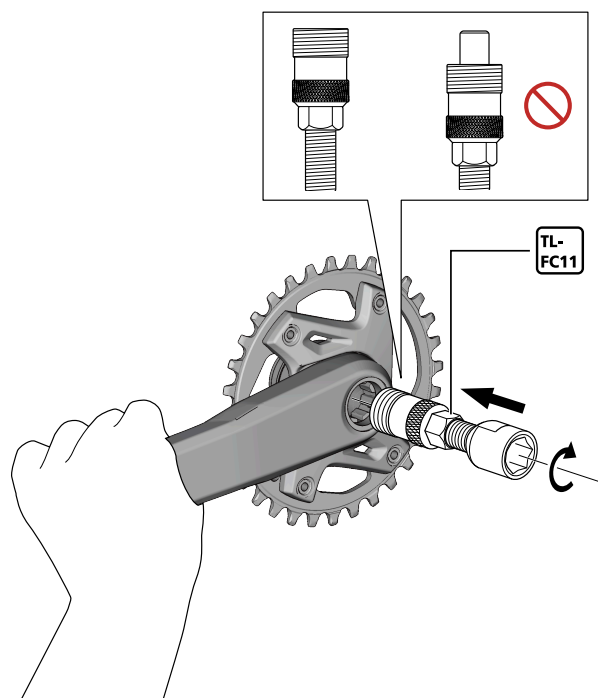

When using TL-FC15 and TL-FC10

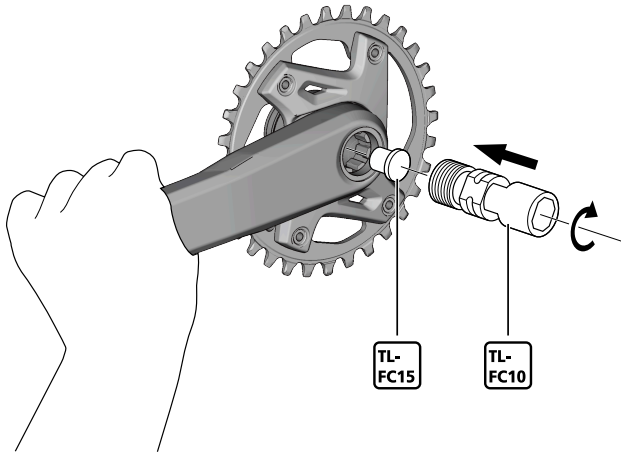

**3. Remove the right crank arm unit from the axle.**

As the SHIMANO original tool is tightened, the right crank arm unit will extract itself from the axle.

**When using a hexagon wrench**

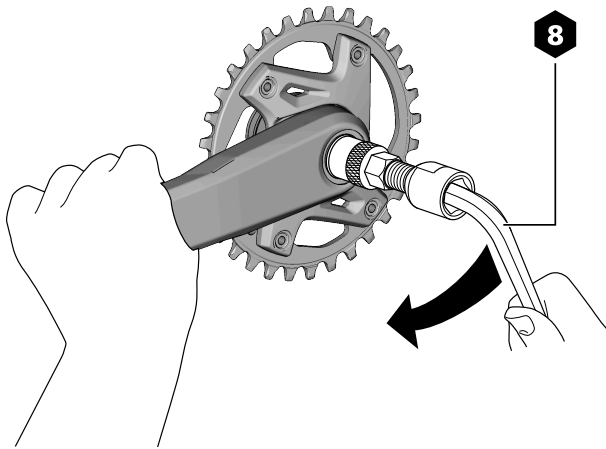

**When using an adjustable wrench**

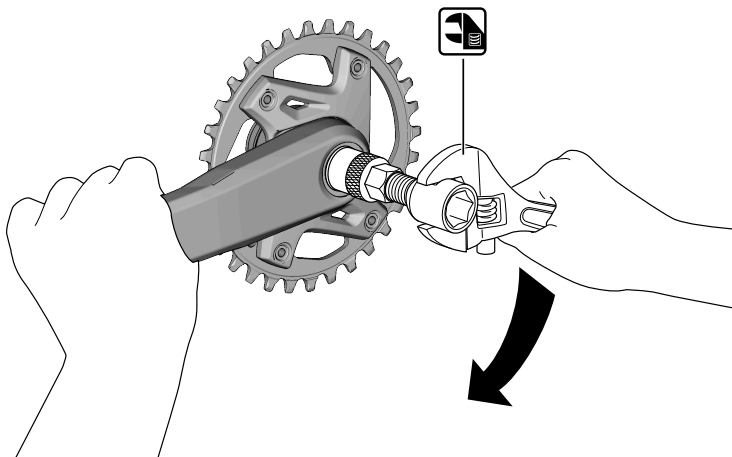

**4. Remove the left crank arm from the bottom bracket.**

## HOLLOWTECH II / 2-PIECE CRANKSET

1. Perform the removal in the reverse order from "[HOLLOWTECH II / 2-PIECE CRANKSET](#)" in "Installing the crankset."

## Square type

### 1. Loosen the crank mounting screw.

After loosening the crank mounting screw, the crankset can be removed from the bottom bracket axle.

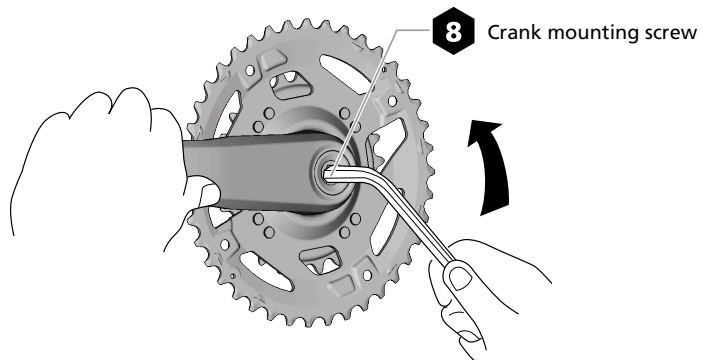

### TECH TIPS

- If the crankset cannot be removed even after removing the crank mounting screw, use the adjustable wrench and the SHIMANO original tool.

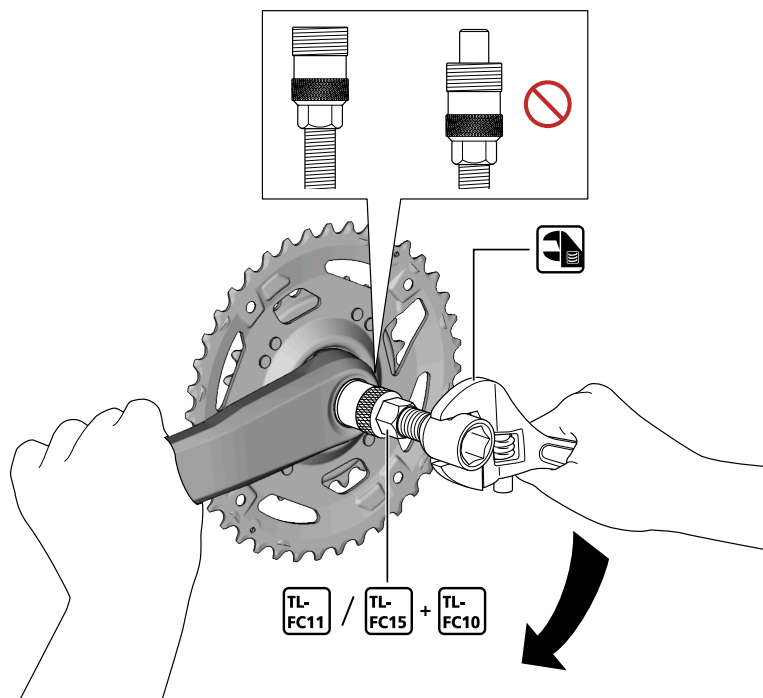

# Maintenance

## Replacing the chainring

Perform the steps of the removal procedure for chainring replacement in the reverse order from the installation procedure.

### NOTICE

- Gear shifting performance will be reduced if the installation positions of the chainrings are incorrect. Be sure to install the chainrings in the correct positions.
- Make sure to use the correct combination of SHIMANO genuine parts, otherwise the crank arms or chainrings may become damaged.

### Single chainring type

FC-U8000-1 / FC-U6040-1 / FC-U6030-1 / FC-U6000-1

1. Remove the chainring.
2. Install the chainring.

With the side with the tooth number marking facing outward, secure it with chainring fixing screws.

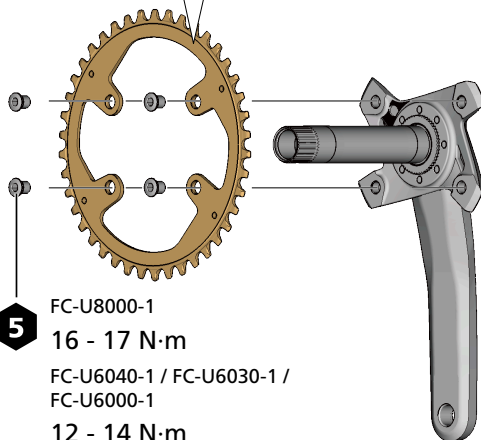
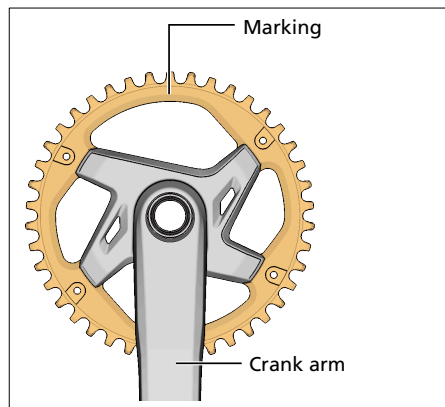

Chainring fixing screw

## NOTICE

- The chainring cannot be replaced for the FC-U4000-1 / FC-U2000-1.

## Double chainring type

### FC-U8000-2

#### 1. Install the largest chainring.

Set the largest chainring with the marked side facing inward.

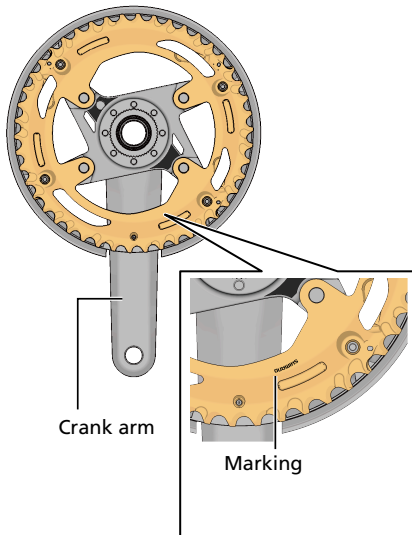

## TECH TIPS

- Do not ride the bicycle with the chain guard removed.

#### 2. Install the smallest chainring.

- (1) With the marked side facing inward, set the smallest chainring so that the alignment tab is positioned under the crank arm.
- (2) Secure it using the chainring fixing screws.

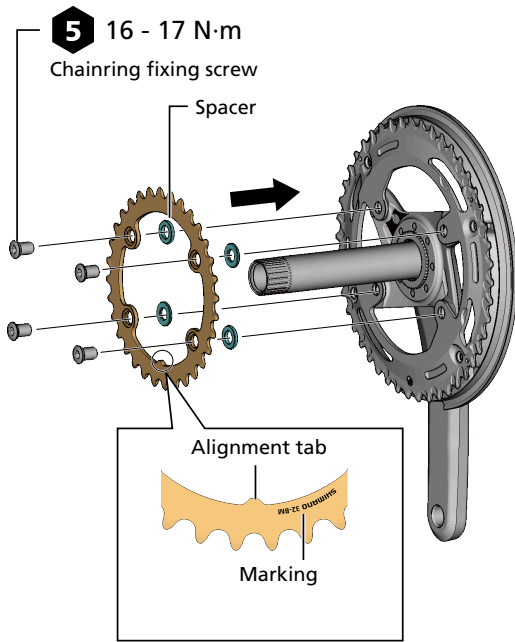

**FC-U6040-2 / FC-U6030-2 / FC-U6010-2 / FC-U6000-2 / FC-U6000-2B**

1. Remove the chainrings.
2. Install the largest chainring.

Ensure the marked side is facing outwards, and that the chain drop prevention pin is positioned under the crank arm.

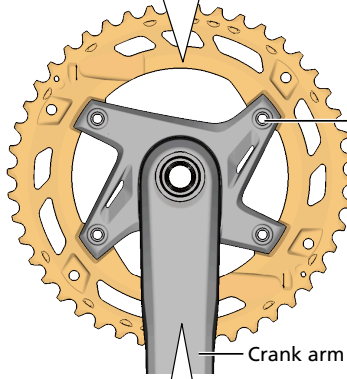
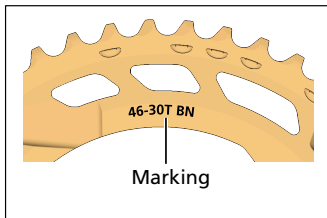

- 5 FC-U6040-2 / FC-U6030-2  
16 - 17 N·m  
FC-U6010-2 / FC-U6000-2 / FC-U6000-2B  
12 - 14 N·m  
Chainring fixing screw

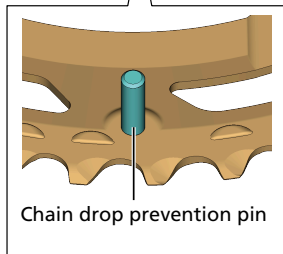

3. Install the smallest chainring.

## Maintenance

### Replacing the chainring

- (1) With the marked side facing inward, set the smallest chainring so that the alignment tab is positioned under the crank arm.
- (2) Secure it using the chainring fixing screws.

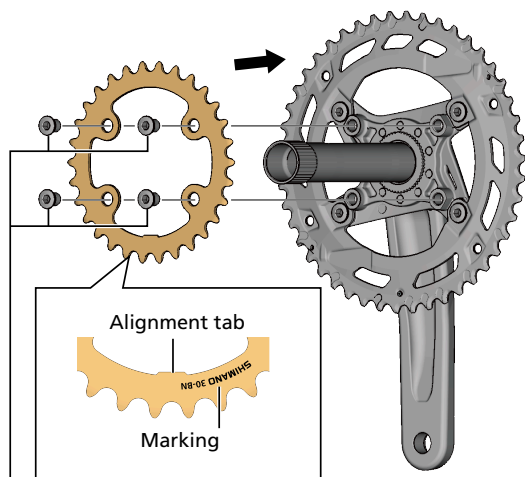

**5** FC-U6040-2 / FC-U6030-2 / 22T  
16 - 17 N·m

FC-U6010-2 / FC-U6000-2 / FC-U6000-2B

12 - 14 N·m

Chainring fixing screw

### **NOTICE**

- The chainring cannot be replaced for the FC-U4010-2 / FC-U4010-2B / FC-U4000-2 / FC-U4000-2B.

# Installing the chain guard

**FC-U8000-2 / FC-U6000-1 / FC-U6000-2 / FC-U6000-2B / FC-U6010-2 / FC-U4000-1 / FC-U4010-2 / FC-U4010-2B / FC-U2000-1**

**1. Set the chain guard to the largest chainring.**

Pass the chain guard over the crank arm, then set the chain guard on the crank and chainring.

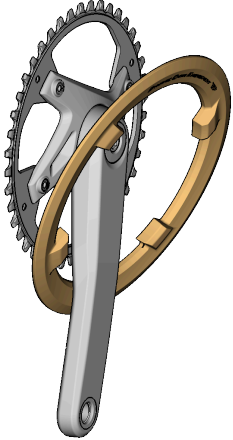

**2. Install the chain guard.**

Secure it using the chain guard fixing screws.

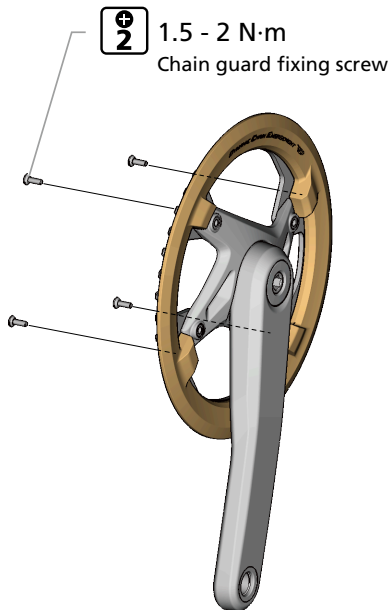

## FC-U8000-1

**1. Set the chain guard to the largest chainring.**

Pass the chain guard over the crank arm, then set the chain guard on the crank and chainring.

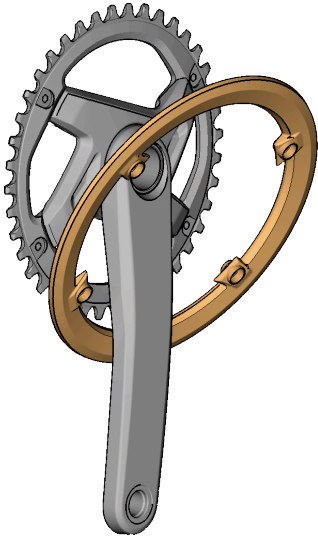

**2. Install the chain guard.**

Secure it using the chain guard fixing screws.

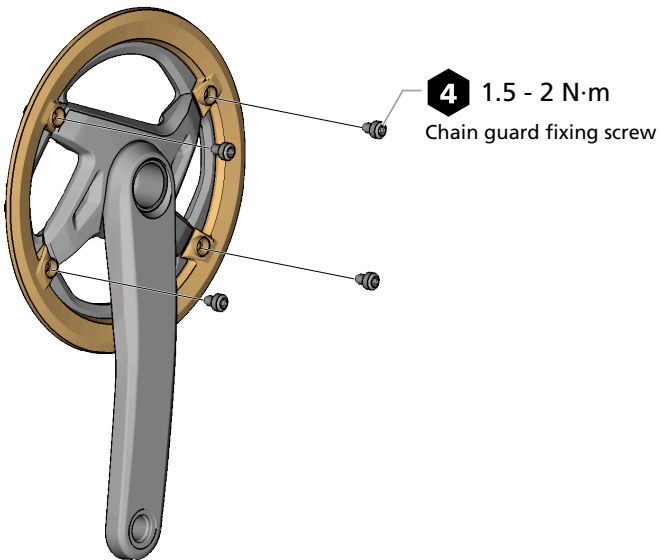

# SHIMANO

**SHIMANO NORTH AMERICA BICYCLE, INC.**  
One Holland, Irvine, California 92618, U.S.A. Phone: +1-949-951-5003

**SHIMANO EUROPE B.V.**  
High Tech Campus 92, 5656 AG Eindhoven, The Netherlands Phone: +31-402-612222

**SHIMANO INC.**  
3-77 Oimatsu-cho, Sakai-ku, Sakai City, Osaka 590-8577, Japan

Please note: specifications are subject to change for improvement without notice. (English)  
© Jul. 2024 by SHIMANO INC. ITP